**Corrosion of metals and alloys —
Classification of low corrosivity of indoor
atmospheres —**

Part 2:
**Determination of corrosion attack in
indoor atmospheres**

*Corrosion des métaux et alliages — Classification de la corrosivité
faible des atmosphères d'intérieur —*

*Partie 2: Détermination de l'attaque par corrosion dans les atmosphères
d'intérieur*



Reference number
ISO 11844-2:2005(E)

© ISO 2005

PDF disclaimer

This PDF file may contain embedded typefaces. In accordance with Adobe's licensing policy, this file may be printed or viewed but shall not be edited unless the typefaces which are embedded are licensed to and installed on the computer performing the editing. In downloading this file, parties accept therein the responsibility of not infringing Adobe's licensing policy. The ISO Central Secretariat accepts no liability in this area.

Adobe is a trademark of Adobe Systems Incorporated.

Details of the software products used to create this PDF file can be found in the General Info relative to the file; the PDF-creation parameters were optimized for printing. Every care has been taken to ensure that the file is suitable for use by ISO member bodies. In the unlikely event that a problem relating to it is found, please inform the Central Secretariat at the address given below.

© ISO 2005

All rights reserved. Unless otherwise specified, no part of this publication may be reproduced or utilized in any form or by any means, electronic or mechanical, including photocopying and microfilm, without permission in writing from either ISO at the address below or ISO's member body in the country of the requester.

ISO copyright office
Case postale 56 • CH-1211 Geneva 20
Tel. + 41 22 749 01 11
Fax + 41 22 749 09 47
E-mail copyright@iso.org
Web www.iso.org

Published in Switzerland

Contents

Page

Foreword	iv
Introduction	v
1 Scope	1
2 Normative references	1
3 Principle	1
4 Methods	1
Annex A (normative) Determination of corrosion rate by mass change measurement	4
Annex B (normative) Determination of corrosion rate by electrolytic cathodic reduction	7
Annex C (informative) Determination of corrosion rate by resistance measurements	9
Bibliography	11

Foreword

ISO (the International Organization for Standardization) is a worldwide federation of national standards bodies (ISO member bodies). The work of preparing International Standards is normally carried out through ISO technical committees. Each member body interested in a subject for which a technical committee has been established has the right to be represented on that committee. International organizations, governmental and non-governmental, in liaison with ISO, also take part in the work. ISO collaborates closely with the International Electrotechnical Commission (IEC) on all matters of electrotechnical standardization.

International Standards are drafted in accordance with the rules given in the ISO/IEC Directives, Part 2.

The main task of technical committees is to prepare International Standards. Draft International Standards adopted by the technical committees are circulated to the member bodies for voting. Publication as an International Standard requires approval by at least 75 % of the member bodies casting a vote.

ISO 11844-2 was prepared by Technical Committee ISO/TC 156, *Corrosion of metals and alloys*.

ISO 11844 consists of the following parts, under the general title *Corrosion of metals and alloys — Classification of low corrosivity of indoor atmospheres*:

- *Part 1: Determination and estimation of indoor corrosivity*
- *Part 2: Determination of corrosion attack in indoor atmospheres*
- *Part 3: Measurement of environmental parameters affecting indoor corrosivity*

Introduction

This part of ISO 11844 describes standard specimens, their exposure and evaluation for the derivation of the indoor corrosivity categories.

The determination of the corrosion attack is, at the present state of knowledge, the most reliable way, and usually also an economical way, for evaluation of corrosivity taking into account all main local environmental influences.

.....

Corrosion of metals and alloys — Classification of low corrosivity of indoor atmospheres —

Part 2: Determination of corrosion attack in indoor atmospheres

1 Scope

This part of ISO 11844 specifies methods for determination of corrosion rate with standard specimens of metals in indoor atmospheres with low corrosivity. For this direct method of evaluation of corrosivity, different sensitive methods can be applied using standard specimens of the following metals: copper, silver, zinc and steel. The values obtained from the measurements are used as classification criteria for the determination of indoor atmospheric corrosivity.

2 Normative references

The following referenced documents are indispensable for the application of this document. For dated references, only the edition cited applies. For undated references, the latest edition of the referenced document (including any amendments) applies.

IEC 60654-4:1987, *Operating conditions for industrial-process measurement and control equipment — Part 4: Corrosive and erosive influences*

ANSI/ISA-S71.04:1985, *Environmental conditions for Process, Measurement and Control Systems: Airborne Contaminants*

3 Principle

The corrosivity of the indoor location, e.g. control rooms, electric boxes, storage rooms, during transportation, in museums, etc., is determined from the corrosion rate calculated from the mass change or resistance change per unit area of standard specimens of metals after exposure for a certain time period. Different materials are sensitive to different environmental parameters or their combinations.

4 Methods

The following methods described in Annexes A and B are available for evaluation of the corrosion attack:

- Determination of corrosion rate by mass change measurements (Annex A)
- Determination of corrosion rate by electrolytic cathodic reduction (Annex B)

The method described in informative Annex C is suitable for continuous or periodic monitoring of the corrosion attack:

- Determination of corrosion rate by resistance measurements (Annex C)

Special features of the methods, such as sensitivity, possibility for continuous or periodic assessment of corrosion attack, available space, etc., should be considered when choosing the most suitable methods. Examples of suitable racks for exposure of specimens are given in Figure 1.

Dimensions in millimetres

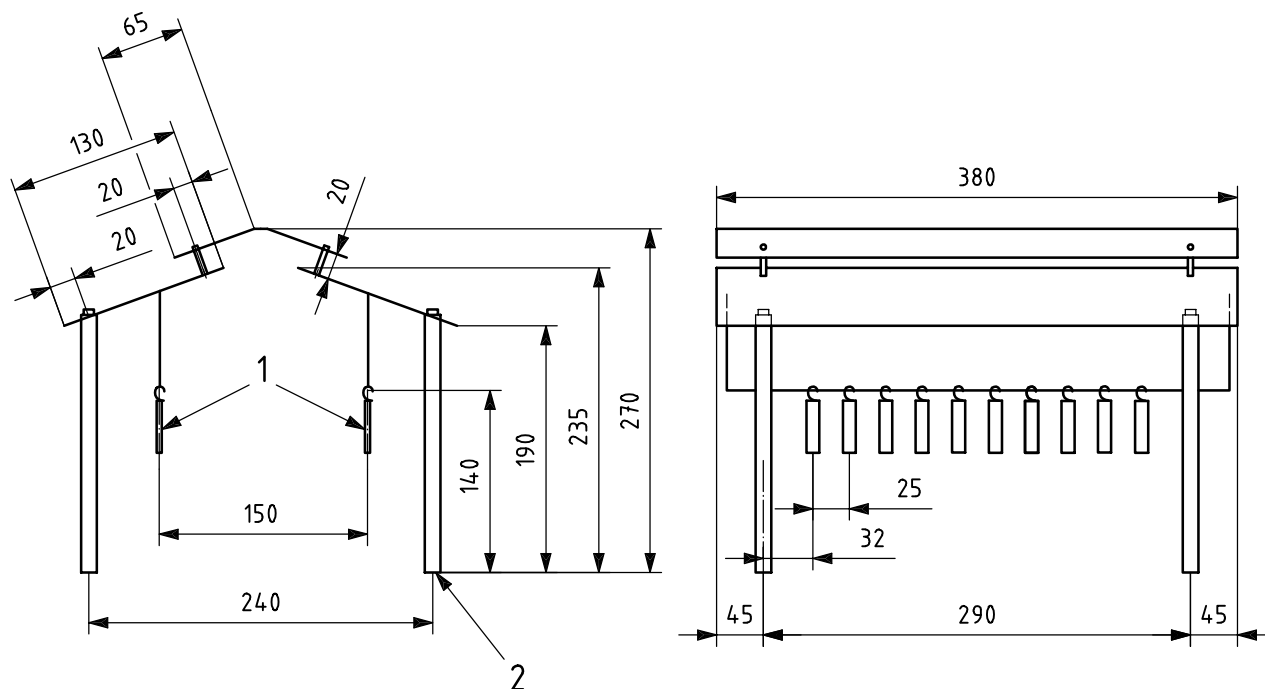

Key

- 1 specimens
- 2 support $\varnothing \sim 15$

a) Sketch of a rack for sheltered exposure of specimens

Figure 1 — Examples of exposure racks with suggested dimensions

Dimensions in millimetres

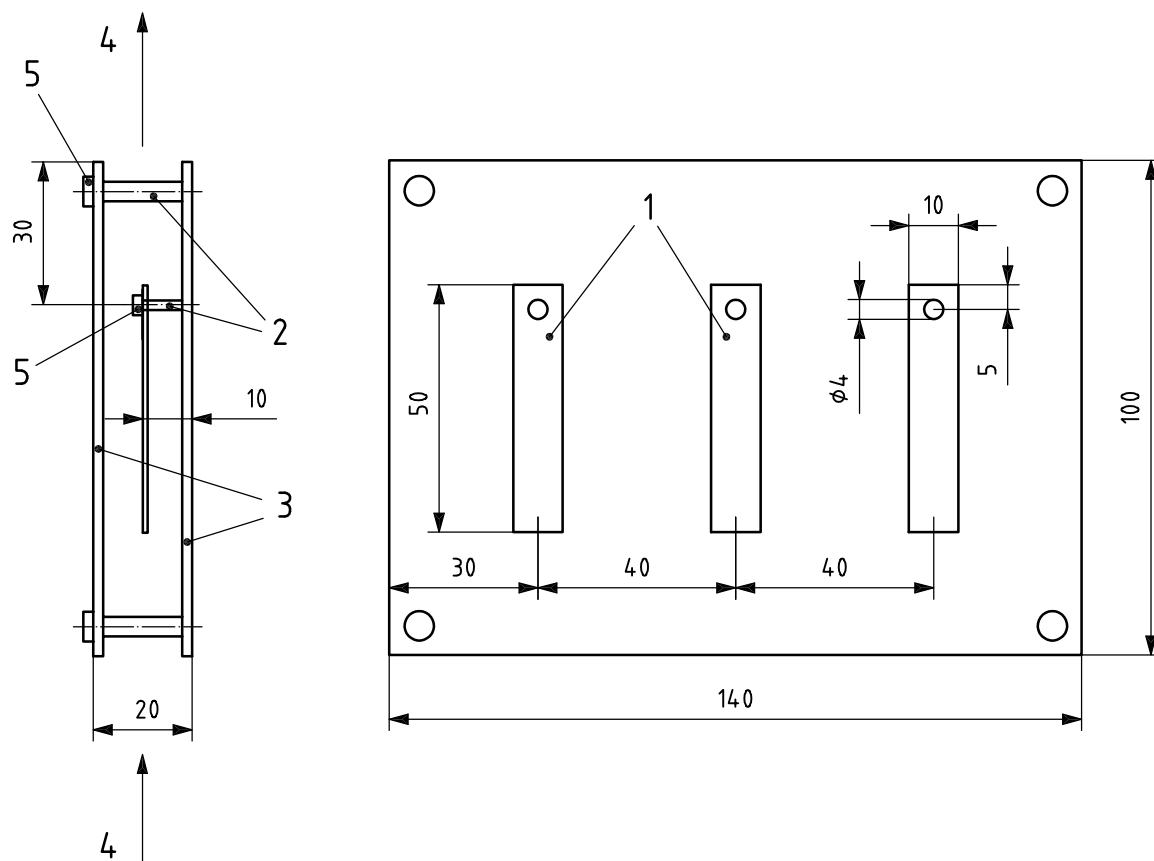

Key

- 1 specimens
- 2 distance pins
- 3 plastic plates
- 4 open air flow
- 5 plastic screws

b) Sketch of a mounting plate for unsheltered exposure of specimens

Figure 1 (continued)

Annex A (normative)

Determination of corrosion rate by mass change measurement

A.1 Principle

Mass increase measurements can be performed on all metals and comparatively large surfaces can be evaluated. The technique is relatively easy to operate.

The mass loss determination gives a best estimate of the corrosion effect. The method is not yet applicable to all metals. Both mass increase and mass loss determination using an ultramicro-balance has a precision of about $\pm 10 \text{ mg/m}^2$ with the method described below.

Due to the difficulty of distinguishing corrosion effects from other surface-related phenomena, such as sorption and contamination by particulate matter, the specimens should preferably be exposed under shelter.

A.2 Specimens

It is preferable to use rectangular specimens in the form of flat sheets, as they can be readily weighed. A convenient specimen size is 10 mm \times 50 mm. Specimens may be larger provided that they can be accurately weighed. The specimen thickness may preferably be 0,5 mm.

The materials used to prepare the specimens are of the following quality,

Silver: 99,98 % min.

Copper: ISO 1336-1337, Cu-DHP, 99,85 % min.

Zinc: 99,45 % min.

Carbon steel: ISO 3574, CR 1, max. 0,15 % C, max. 0,04 % P, max . 0,05 % S, max. 0,6 % Mn

The specimens should, before weighing, be prepared as follows:

- a) A hole with diameter 4 mm is cut at the upper side of the specimen.
- b) Abrading¹⁾
 - Silver and copper with silicon carbide paper to 1 200 P (600 grit).
 - Zinc and carbon steel to 500 P (320 grit).
- c) Cleaning in deionised water.
- d) Degreasing in ethanol in an ultrasonic bath for 5 min.
- e) Drying.

1) To avoid risk of contamination, an abrading paper must not be used for polishing specimens of different metals.

- f) Store in plastic tubes with a hole in the top. The plastic tubes are placed in a desiccator or sealed into plastic bags with desiccant before and after the weighing and the exposure.

After final surface cleaning before exposure, it is important that limited handling occurs. Before and after weighing, the specimens are placed in tubes and are only handled with a clean pair of tweezers. To avoid marking on the specimens, the identity of the specimens may preferably be marked on the tubes.

A.3 Exposure

The specimens shall be exposed vertically, either with or without a shelter against settling particles (see Figure 1). The specimens shall be mounted between plastic plates or racks to permit free air circulation. A distance of a minimum of 10 mm between the surfaces and/or the surface and the mounting plate is recommended. The plastic racks or mounting plates are placed at a site with free air circulation, preferably at a height of 1 m above the floor. The exposure should be performed in an area with airflow rates characteristic of the site.

A map of specimen identity on the plastic rack, exposure date and location of the exposure rack should be established. The type of exposure, with or without a shelter, should be noted.

The test specimens (at least three) should be exposed preferably for one year but at least for six months.

A.4 Mass increase

The specimens shall be weighed on a micro-balance, with an accuracy of $\pm 0,1 \mu\text{g}$. Each test specimen is weighed twice in relation to a reference balance standard of stainless steel having a similar mass to the specimen. The difference between the first mass of the test specimen m_1 and the reference balance standard $m_{r,1}$ is calculated as $(m_{r,1} - m_1)$, and the difference between the second masses $(m_{r,2} - m_2)$ is calculated in the same way. The mass of the test specimen is calculated in relation to the reference specimen as the average of the differences (m):

$$m = \frac{(m_{r,1} - m_1) + (m_{r,2} - m_2)}{2}$$

where

m is the mass of the test specimen in relation to the reference balance standard, in mg;

m_1 is the mass of the test specimen at first weighing, in mg;

m_2 is the mass of the test specimen at second weighing, in mg;

$m_{r,1}$ is the mass of the reference balance standard at first weighing, in mg;

$m_{r,2}$ is the mass of the reference balance standard at second weighing, in mg.

The same weighing procedure is performed both before and after the exposure of the specimens. After the exposure, the specimens should be carefully blown with oil-free compressed air or nitrogen to remove dust before the weighing.

The rate of mass increase for each metal is given by the following equation:

$$r_{mi} = \frac{m_{ae} - m_{be}}{A \cdot t}$$

where

- r_{mi} is the rate of mass increase in $\text{mg}/\text{m}^2\cdot\text{a}$
- m_{ae} is the mass of the test specimen in relation to the reference balance standard after exposure, in mg;
- m_{be} is the mass of the test specimen in relation to the reference balance standard before exposure, in mg;
- A is the surface area including both sides and edges, in m^2 ;
- t is the exposure time; in years (with the unit symbol a).

A.5 Mass loss

The specimens shall be weighed on a micro-balance, with an accuracy of $\pm 0,1 \mu\text{g}$. The specimens are weighed in relation to a reference balance standard of stainless steel before exposure, see the description in Clause 3. After the exposure, the specimens are pickled in the following solutions:

- Silver: 750 ml hydrochloric acid (HCl, density = 1,18 g/ml). Distilled water to make up to 1 000 ml
- Copper: aqueous amidosulfonic acid (sulfamic acid) with a volume fraction of 5 %
- Zinc: saturated glycine solution
- Carbon steel: concentrated hydrochloric acid, 20 g/l Sb_2O_3 , 50 g/l SnCl_2 .

Measurement of the mass after repetitive cleaning cycles is the normal method for determining the mass loss of corroded specimens (see ISO 8407). In this part of ISO 11844, however, a simplified procedure with the use of a blank is recommended, since the weighing of specimens on a micro-balance requires significant time compared to the usual weighing procedure.

The pickling time depends on the severity of the corrosion attack but is usually 1 min to 2 min. The time should be long enough to ensure that the sample is clean and all corrosion products have been removed. During the pickling, an unexposed specimen (blank) of each material shall be included. After the pickling, the specimens are weighed on the micro-balance, using the same procedure as before exposure. The mass loss of the unexposed specimen, which shows the loss of base material during the pickling, should be withdrawn from the mass loss of the pickled specimens.

The corrosion rate is given by the following equation:

$$r_{\text{corr}} = \frac{(m_{be} - m_{ap}) - (m_{bp\text{-}blank} - m_{ap\text{-}blank})}{A \cdot t}$$

where

- r_{corr} is the corrosion rate, in $\text{mg}/\text{m}^2\cdot\text{a}$;
- m_{be} is the mass of the specimen in relation to the reference specimen before exposure, in mg;
- m_{ap} is the mass of the specimen in relation to the reference specimen after pickling, in mg;
- $m_{bp\text{-}blank}$ is the mass of the blank specimen in relation to the reference specimen before pickling, in mg;
- $m_{ap\text{-}blank}$ is the mass of the blank specimen in relation to the reference specimen after pickling, in mg;
- A is the surface area, including both sides and edges, in m^2 ;
- t is the exposure time, in years.

Annex B (normative)

Determination of corrosion rate by electrolytic cathodic reduction

B.1 Principle

This method is applicable for the determination of corrosion attack on silver and copper. Analyses may consist of the determination of film thickness or mass loss. For film thickness measurements, the composition of corrosion products present at the surface of the specimen shall be estimated from the cathodic reduction curves. The mass loss on silver can be calculated without assumption of composition of the corrosion products, since all silver compounds exist in valence state +1. For copper, the possible presence of both +1 valency and +2 valency compounds is a source of uncertainty. The method is estimated to have a precision of about $\pm 10 \text{ mg/m}^2$ for mass loss on copper.

B.2 Specimens

It is preferable to use rectangular specimens in the form of flat sheets. A convenient specimen size for exposure is 10 mm \times 50 mm. Larger specimens can be exposed. The materials used to prepare the specimens are of the following quality:

Silver: 99,98 % min.

Copper: ISO 1336-1337, Cu-DHP, 99,85 % min.

Before weighing, the specimens should be prepared as follows:

- a) A hole with diameter 4 mm is cut at the upper side of the specimen.
- b) Abrading with silicon carbide paper to 1 200 P (600 grit).²⁾
- c) Cleaning in deionised water.
- d) Degreasing in ethanol in an ultrasonic bath for 5 min.
- e) Drying.
- f) Store in plastic tubes with a hole in the top. The plastic tubes are placed in a desiccator or sealed into plastic bags with desiccant before and after the weighing and the exposure.

After final surface cleaning before exposure, it is important that limited handling occurs. Before and after weighing, the specimens are placed in plastic tubes and are only handled with a clean pair of tweezers. To avoid marking on the specimens, the identity of the specimens may preferably be marked on the tubes.

B.3 Exposure

The specimens shall be exposed vertically, either with or without a shelter for settling particles (see Figure 1). The specimens shall be mounted between plastic plates or racks to permit free air circulation. A distance of a

2) To avoid risk of contamination, an abrading paper must not be used for polishing specimens of different metals.

minimum of 10 mm between the surfaces and/or the surface and the mounting plate is recommended. The plastic racks or mounting plates are recommended. The plastic racks or mounting plates are placed at a site with free air circulation, preferably at a height of 1 m above the floor. The exposure should be performed in an area with airflow rates characteristic of the site.

A reliable map of specimen identity on the plastic rack, exposure date and location of the exposure rack should be established. The type of exposure, with or without shelter, should be noted.

The number of test specimens of each type should not be less than three for each exposure time interval. The test specimens should be exposed preferably for one year, but at least for six months.

B.4 Electrolytic cathodic reduction

The electrolytic cathodic reduction shall be performed in a 0,1 M KCl solution at a constant current density of 125 $\mu\text{A}/\text{cm}^2$. A standard three-electrode cell should be used, containing N_2 -purged 0,1 M KCl as the electrolyte, a platinum counter electrode, a calomel reference electrode and the specimen as the working electrode. The change of the potential of the specimen is monitored during the electrolytic reduction of the corrosion products. The corrosion rate, r_{corr} , in $\text{mg}/(\text{m}^2\cdot\text{a})$, is given by the following equation (Faraday's law):

$$r_{\text{corr}} = \frac{i \cdot t_{\text{red}} \cdot M}{n \cdot F \cdot t}$$

where

- r_{corr} is the corrosion rate, in $\text{mg}/\text{m}^2\cdot\text{a}$;
- i is the current density, in mA/m^2 ;
- t_{red} is the total time for reduction of corrosion products, in seconds
- M is the relative molecular mass, in g, i.e. 107,9 for silver and 63,5 for copper;
- n is the valance state, i.e. +1 for silver, +1 or +2 for copper;
- F is Faraday's constant, 96 485 C/mol;
- t is the exposure time, in years

In ANSI/ISA-S71.04-1985 and IEC 60654-4, the classification of reactive environments is based on the copper reactivity, expressed as the thickness of the copper corrosion film. From the corrosion rate, r_{corr} , determined above, a corresponding film thickness, t_f , is obtained from the following equation:

$$t_f = \frac{r_{\text{corr}} \cdot M_{\text{film}} \cdot t}{M \cdot \delta_{\text{film}}}$$

where

- t_f is the thickness of the corrosion film, in nm (10^{-9} m);
- r_{corr} is the corrosion rate, in $\text{mg}/\text{m}^2\cdot\text{a}$;
- t is the exposure time, in years;
- M is the relative molecular mass, in g, i.e. 107,9 for silver and 63,5 for copper.
- M_{film} is the relative molecular mass of the corrosion film, in g, e.g. $\text{Ag}_2\text{S} = 247,8$; $\text{Cu}_2\text{O} = 143,1$; $\text{CuO} = 79,5$;
- δ_{film} is the density of the corrosion film in g/cm^3 , e.g. $\text{Ag}_2\text{S} = 7,32$; $\text{Cu}_2\text{O} = 6,0$; $\text{CuO} = 6,4$

Annex C (informative)

Determination of corrosion rate by resistance measurements

C.1 Principle

Resistance sensors are used for assessment of the corrosion rate, based on the change of the electrical resistance of thin metal films upon corrosion. Resistance measurements can in principle be performed on all metals. The resistance sensor consists of a thin film shaped in a serpentine pattern, with two electrical taps at each end and one at the centre. The geometry provides two identical resistive elements, one of which is the corrosion-measurement surface and the other which is the reference element used for temperature compensation. The reference element is coated with an insulating material to protect it from being attacked by the environments where the corrosivity is being measured. Changes between the electrical resistance of the reference side and the corrosion side of the sensor are related to corrosion rate. Semiconducting corrosion products and non-uniform corrosion may cause problems during interpretation.

C.2 Specimens

The sensors are at present commercially available for silver, copper and carbon steel. The thickness of the foils is from 50 nm to 2 500 nm, preferably 250 nm. The films are produced by deposition of metal on an inert material surface.

C.3 Exposure

The specimens are exposed vertically either with or without a shelter for setting particles (see Figure 1). The specimens shall be mounted between plastic plates or racks to permit free air circulation. A distance of a minimum of 10 mm between the surfaces and/or the surface and the mounting plate is recommended. The plastic racks or mounting plates are placed at a site with free air circulation, preferably at a height of 1 m above the floor. The exposure should be performed in an area with airflow rates characteristic of the site.

The number of specimens of each type should be at least two. The specimens should be exposed preferably for one year but at least for six months. A reliable map of specimen identity on the plastic rack, exposure date and location of the exposure rack should be established. The type of exposure, with or without shelter, should be noted.

C.4 Measurements

Changes in the electrical resistance of the exposed part of the specimen in relation to the protected part should be measured at regular intervals, but at least every three months.

The corrosion rate is given by the equation:

$$r_{\text{corr}} = \frac{\left(\frac{R_{\text{exp}}}{(R_{\text{prot}})_{\text{exp}}} - \frac{R_0}{(R_{\text{prot}})_0} \right) \cdot C \cdot \delta_{\text{metal}}}{10 \cdot t}$$

where

- r_{corr} is the corrosion rate, in $\text{mg}/\text{m}^2\cdot\text{a}$;
- R_{exp} is the resistance for the non-protected part of the specimen after exposure;
- $(R_{\text{prot}})_{\text{exp}}$ is the resistance for the protected part of the specimen after exposure;
- R_0 is the resistance for the non-protected part of the specimen before exposure;
- $(R_{\text{prot}})_0$ is the resistance for the protected part of the specimen before exposure;
- δ_{metal} is the density of the metal, in g/cm^3 , i.e. Ag = 10,50 ; Cu = 8,93;
- C is a constant, specific for the specimen and given by the manufacturer in 10^{-10} m;
- t is the exposure time, in years.

Bibliography

- [1] ISO 1336, *Wrought coppers (having minimum copper contents of 97,5 %) — Chemical composition and forms of wrought products*
- [2] ISO 1337, *Wrought coppers (having minimum copper contents of 99,85 %) — Chemical composition and forms of wrought products*
- [3] ISO 3574, *Cold-reduced carbon steel sheet of commercial and drawing qualities*
- [4] ISO 8407, *Corrosion of metals and alloys — Removal of corrosion products from corrosion test specimens*
- [5] ISO 9223:1992, *Corrosions of metals and alloys — Corrosivity of atmospheres — Classification*
- [6] ISO 9226:1992, *Corrosion of metals and alloys — Corrosivity of atmospheres — Determination of corrosion rate of standard specimens for the evaluation of corrosivity*
- [7] ISO 11844-1³⁾, *Corrosion of metals and alloys — Classification of low corrosivity of indoor atmospheres — Part 1: Determination and estimation of indoor corrosivity*

3) Being prepared.

www.iso.org

ICS 77.060

Price based on 11 pages