

INTERNATIONAL  
STANDARD

**ISO**  
**11785**

First edition  
1996-10-15

---

---

**Radio-frequency identification of animals —  
Technical concept**

*Identification des animaux par radiofréquence — Concept technique*

This material is reproduced from ISO documents under International Organization for Standardization (ISO) Copyright License number IHS/ICC/1996. Not for resale. No part of these ISO documents may be reproduced in any form, electronic retrieval system or otherwise, except as allowed in the copyright law of the country of use, or with the prior written consent of ISO (Case postale 56, 1211 Geneva 20, Switzerland, Fax +41 22 734 10 79), IHS or the ISO Licensor's members.



Reference number  
ISO 11785:1996(E)

## Foreword

ISO (the International Organization for Standardization) is a worldwide federation of national standards bodies (ISO member bodies). The work of preparing International Standards is normally carried out through ISO technical committees. Each member body interested in a subject for which a technical committee has been established has the right to be represented on that committee. International organizations, governmental and non-governmental, in liaison with ISO, also take part in the work. ISO collaborates closely with the International Electrotechnical Commission (IEC) on all matters of electrotechnical standardization.

Draft International Standards adopted by the technical committees are circulated to the member bodies for voting. Publication as an International Standard requires approval by at least 75 % of the member bodies casting a vote.

International Standard ISO 11785 was prepared by Technical Committee ISO/TC 23, *Tractors and machinery for agriculture and forestry*, Subcommittee SC 19, *Agricultural electronics*.

Annexes A and B form an integral part of this International Standard. Annex C is for information only.

© ISO 1996

All rights reserved. Unless otherwise specified, no part of this publication may be reproduced or utilized in any form or by any means, electronic or mechanical, including photocopying and microfilm, without permission in writing from the publisher.

International Organization for Standardization  
Case Postale 56 • CH-1211 Genève 20 • Switzerland

Printed in Switzerland

## Introduction

The technical concept of animal identification described is based upon the principle of radio-frequency identification (RFID). ISO 11785 is applicable in connection with ISO 11784 which describes the structure and the information content of the codes stored in the transponder.

The International Organization for Standardization (ISO) draws attention to the fact that compliance with clause 6 and annex A of this International Standard may involve the use of patents concerning methods of transmission.

ISO takes no position concerning the evidence, validity and scope of these patent rights.

The following patent holder has assured ISO that he will not exert its patent rights concerning FDX B technology:

NEDAP Agri BV  
Postbus 9  
NL-7255 ZG Hengelo  
  
Tel. + 31 575 46 38 00  
Fax + 31 575 46 37 25

The following patent holders have assured ISO that they are willing to negotiate licences under reasonable and non-discriminatory terms and conditions with applicants throughout the world. In this respect, the statement of the holders of these patents rights are registered with ISO:

Destron Fearing Corporation  
490 Villaume Avenue  
USA-South St. Paul, MN 55075-2445  
  
Tel. + 1 612 455 1263  
Fax + 1 612 455 0413

Datamars SA  
Via Ponteggia  
CH-6814 Cadempino-Lugano  
  
Tel. + 41 91 58 27 01  
Fax + 41 91 58 27 41

Texas Instruments Limited  
800 Pavilion Drive  
Northampton Business Park  
GB-Northampton NN4 7YL  
  
Tel. + 44 1604 663 000  
Fax + 44 1604 663 001

TROVAN Limited  
c/o Gruenguertelstr. 12  
D-50996 Cologne

Tel. + 49 221 391 431  
Fax + 49 221 395 893

Attention is moreover drawn to the possibility that some of the elements of this International Standard may be the subject of patent rights other than those identified above. ISO shall not be held responsible for identifying any or all such patent rights. In that connection, additional correspondences were received from two other companies (AVID and EID) not willing to forward pertinent declaration in accordance with the current ISO Directives.

Copies of declarations and statements received from all the above mentioned companies are available upon request to the ISO Central Secretariat.

# Radio-frequency identification of animals — Technical concept

## 1 Scope

This International Standard specifies how a transponder is activated and how the stored information is transferred to a transceiver.

## 2 Conformance

Transponders are in conformance with this International Standard provided they meet the requirements given in clause 6 of this International Standard. Transceivers are in conformance with this International Standard provided they meet the requirements given in clause 6 and annex A, if the latter is applicable.

In order to allow a smooth transition from the different transponders presently in use to those complying with this International Standard, transponders meeting the requirements of annex A may be applied for a transition period of two years from the date of the first edition of this International Standard.

## 3 Normative references

The following standard contains provisions which, through reference in this text, constitute provisions of this International Standard. At the time of publication, the edition indicated was valid. All standards are subject to revision, and parties to agreements based on this International Standard are encouraged to investigate the possibility of applying the most recent edition of the standard indicated below. Members of IEC and ISO maintain registers of currently valid International Standards.

ISO 11784:1996, *Radio-frequency identification of animals — Code structure*.

## 4 Definitions

For the purposes of this International Standard, the following definitions apply.

- 4.1 activation field:** Electromagnetic field transmitted by a transceiver to energize and/or activate a transponder.
- 4.2 activation frequency:** Frequency of the activation field.
- 4.3 activation period:** Time duration of the activation signal.

- 4.4 bit rate:** Number of bits transmitted per second.
- 4.5 differential bi-phase encoding:** Method of encoding in which data bit 0 is represented by a mid-bit transition; data bit 1 is represented by no transition; and there is always a transition in between two bits.
- 4.6 encoding:** One to one relationship between basic information elements and modulation patterns.
- 4.7 error detection code:** Bits that contain information which can be used to detect errors.
- 4.8 frequency shift keying:** Binary information is superimposed onto a carrier electromagnetic field by shifting between discrete frequencies of the field.
- 4.9 full duplex:** Method of information exchange in which the information is communicated while the transceiver transmits the activation field.
- 4.10 half duplex:** Method of information exchange in which the information is communicated after the transceiver has stopped transmitting the activation field.
- 4.11 header:** Bits transmitted before the useful information, uniquely identifying the start of a page, which may also be used for synchronization of the transponder and the transceiver.
- 4.12 identification code:** 64 bits of the identification telegram which are specified in ISO 11784.
- 4.13 identification telegram:** The total identification message (header, identification code, error detection code and trailer), possibly repeatedly transmitted by the transponder upon activation.
- 4.14 mobile transceiver:** Transceiver that is not connected to other transceivers when these are in its vicinity to synchronize activation periods and pauses.
- 4.15 modulation:** Method of superimposing information onto an electromagnetic field by means of varying a specific parameter of the field.
- 4.16 non-return to zero encoding:** Method of encoding in which data bit 1 is a high signal and data bit 0 is a low signal.
- 4.17 page:** A coherent part of the communicated information.
- 4.18 phase shift keying:** Binary information is superimposed onto a carrier electromagnetic field by introducing discrete phase shifts of the field.
- 4.19 stationary transceiver:** Transceiver that is connected to other transceivers when these are in its vicinity to synchronize activation periods and pauses.
- 4.20 trailer:** Bits transmitted after the error detection code; the content of which is dependent upon the value of the flag for an additional data block which is specified in ISO 11784.
- 4.21 transceiver:** Device used to communicate with a transponder.
- 4.22 transponder:** Device which transmits its stored information when activated by a transceiver and may be able to store new information.

## 5 Abbreviations

<b>AM</b>	amplitude modulation
<b>BCC</b>	block control character
<b>CRC</b>	cyclic redundancy check
<b>DBP</b>	differential bi-phase encoding
<b>FDX</b>	full duplex
<b>FSK</b>	frequency shift keying
<b>HDX</b>	half duplex
<b>LSB</b>	least significant bits
<b>MSB</b>	most significant bits
<b>NRZ</b>	non-return to zero encoding
<b>PSK</b>	phase shift keying
<b>RFID</b>	radio-frequency identification

## 6 Requirements

The system shall be defined in such a way that the FDX and HDX transponders can be read by one transceiver. Annex A describes the method that can be used to enhance the functionality of this transceiver to read certain installed base transponders which are not compatible with the FDX and HDX transponders described in this clause.

A stationary transceiver shall activate transponders using an activation field with an activation frequency of  $(134,2 \pm 13,42 \times 10^{-3})$  kHz. The activation period shall be 50 ms. If an FDX signal is received during activation but is not validated, the activation period shall be extended until the identification telegram is validated, but not longer than 100 ms. Consecutively, there shall be a pause in the activation signal. If an HDX signal is received the pause shall last for 20 ms. If no HDX signal is detected within 3 ms after a 3 dB decay of the activation field, activation shall be resumed. For synchronization reasons, each tenth activation cycle shall have a fixed pattern of 50 ms activation and 20 ms pause (see annex C).

A mobile transceiver shall be able to detect the presence of additional active transceivers through the reception of activation signals. If no activation signal is detected within 30 ms, the mobile transceiver is out of reach of other active transceivers and shall use the activation protocol defined above for a stationary transceiver. If the mobile transceiver does detect an activation signal it shall wait for the rising edge of the next activation signal and shall activate during a fixed period of 50 ms.

The identification code shall be in accordance with ISO 11784. The identification code, the CRC error detection bits (see annex B) and the trailer shall be transmitted starting with the LSB and ending with the MSB.

In view of future enhancements, for example multi-page transponders incorporating sensors and/or writable memory, the identification telegram shall terminate in 24 trailer bits in which, for instance, information from sensors or the contents of trailing pages may be stored. If the flag for additional data blocks, which is specified in ISO 11784, is binary 0 the value of most of the trailer bits is unspecified. The value of the trailer bits for additional data blocks which have a flag equal to binary 1 will be defined by a future International Standard.

### NOTES

- 1 Since errors in the trailer will not be detected by the error detection protocol of the identification telegram, it is not necessary to read these bits in order to correctly detect the identification code.
- 2 In most countries the use of transceivers as described in this International Standard is subject to regulations. Type approval from the national regulatory agencies may be required before they can be operated or traded in these countries.

### 6.1 Full duplex system

An FDX transponder receiving the activation field shall transmit its code during the activation period. The FDX transponder uses a modified DBP encoded sub-carrier which is amplitude modulated upon the radio frequency

carrier. Because the slope of a low-high transition is not infinitely steep, every low-high transition is advanced in time to a maximum of eight cycles to obtain optimal performance (see figure 1). The transponder shall send its message back using the frequency bands 129,0 kHz to 133,2 kHz and 135,2 kHz to 139,4 kHz. The duration of one bit is 32 activation field cycles. This corresponds to a bit rate of 4 194 bit/s.

NOTE — The basic frequency of the sub-carrier, containing the phase encoded data signal, is not influenced by the advancement in time of the low-high transition and remains 4 194 Hz (binary 1: 180° phase shift; binary 0: no phase shift).

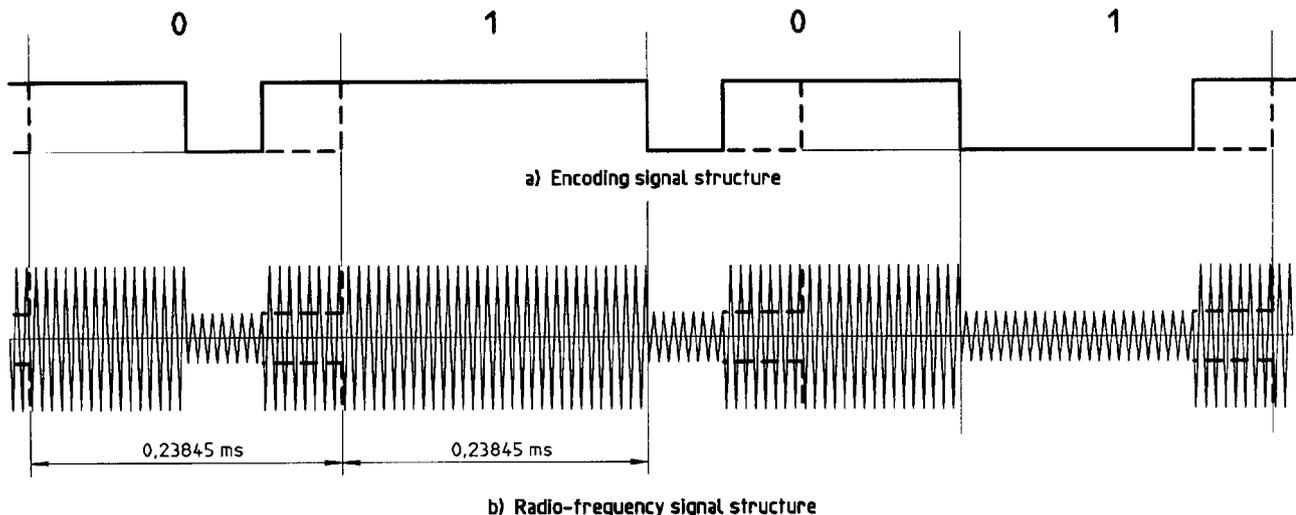

Figure 1 — Signal structures of the FDX identification telegram

The structure of the FDX identification telegram (see figure 2) is as follows:

- a header of 11 bits (00000000001) used to identify the start of the identification telegram;
- a 64-bit identification code transmitted in eight blocks of 8 bits;
- two blocks of 8 bits containing the 16 CRC error detection bits;
- three blocks of 8 bits containing the 24 trailer bits.

The error detection code is calculated solely over the identification code. Each block of 8 bits is trailed by a control bit with the value binary 1 to prevent the appearance of the header in the rest of the identification telegram.

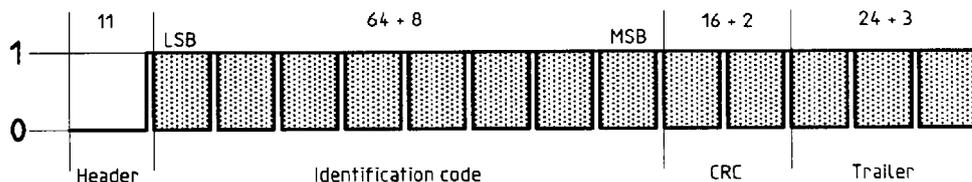

Figure 2 — Structure of the FDX identification telegram

6.2 Half duplex system

If no FDX signal was received during activation, or if an FDX signal was received and validated, the activation shall cease after 50 ms and an interruption of the activation field shall be maintained during at least 3 ms. The decay of the activation field from -3 dB to -80 dB shall be completed within 1 ms. An HDX transponder charged with energy during the activation uses the interruption to transmit its signal. The HDX transponder shall respond between 1 ms and 2 ms after a 3 dB decay of the activation signal. If no HDX signal is detected within 3 ms after a 3 dB decay of the activation signal, activation shall be resumed (see figure 3).

The HDX transponder uses FSK modulation at  $(124,2 \pm 2)$  kHz to transmit a binary 1 and at  $(134,2 \pm 1,5)$  kHz to transmit a binary 0. The encoding of the signal shall be NRZ. The duration of a bit is 16 cycles, corresponding to a bit rate of 8 387,5 bit/s for binary zeros and 7 762,5 bit/s for binary ones (see figure 4).

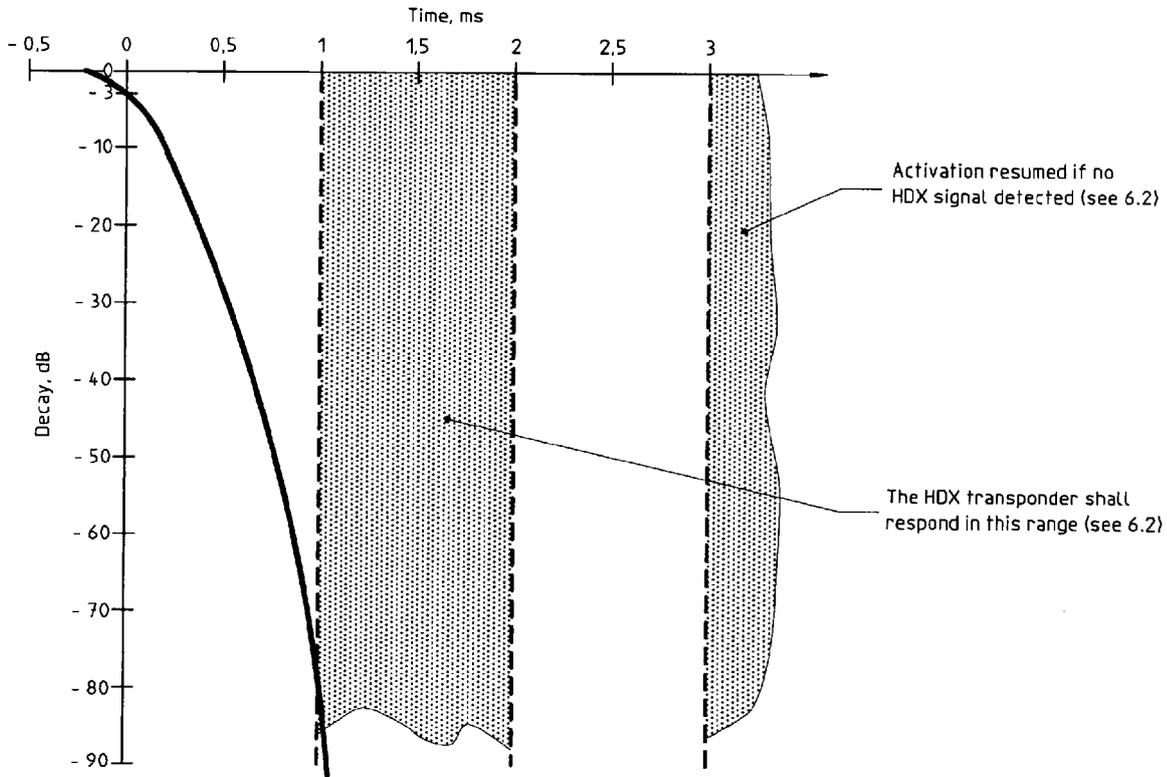

Figure 3 — Timing of the decay of the activation field

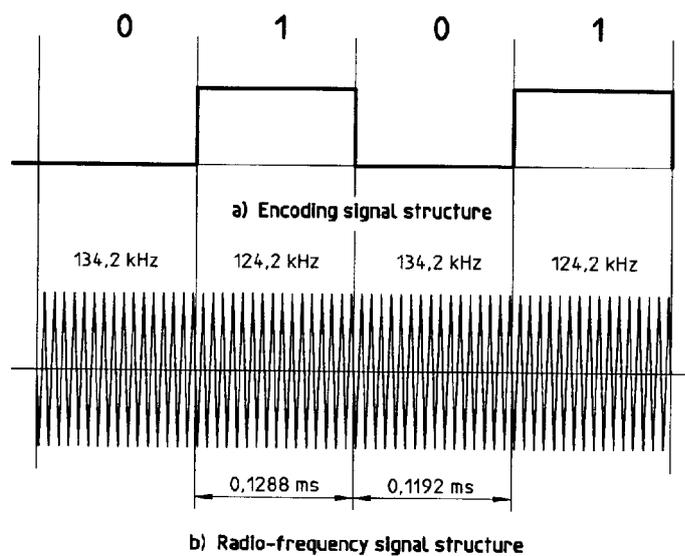

Figure 4 — Signal structures of the HDX identification telegram

The structure of the HDX identification telegram (see figure 5) is as follows:

- a header of 8 bits (01111110) used as a synchronization sequence;
- a 64-bit identification code;
- 16 CRC error detection bits;
- 24 trailer bits.

If the flag for additional data blocks is binary 0 the values of the first eight trailer bits shall be 01111110. The error detection code is calculated solely over the identification code.

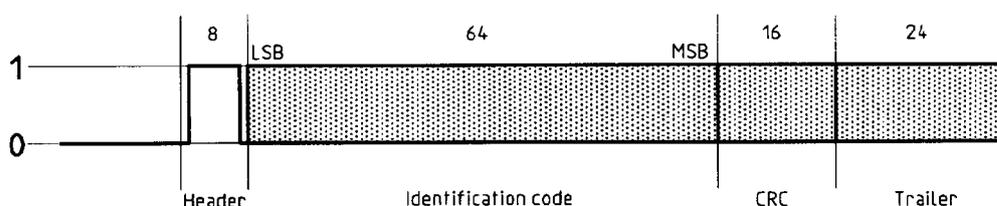

Figure 5 — Structure of the HDX identification telegram

Table 1 — Summary of the FDX and HDX systems

Parameter	FDX system	HDX system
Activation frequency	134,2 kHz	134,2 kHz
Modulation	AM-PSK	FSK
Return frequencies	129,0 kHz to 133,2 kHz 135,2 kHz to 139,4 kHz	124,2 kHz (1) 134,2 kHz (0)
Encoding	modified DBP	NRZ
Bit rate	4 194 bit/s	7 762,5 bit/s (1) 8 387,5 bit/s (0)
Telegram structure:		
— Header	11	8
— Identification code	64	64
— Error detection code	16	16
— Trailer	24	24
— Control bits	13	—

## Annex A (normative)

### Integration of installed bases

#### A.1 Introduction

This International Standard specifies a transceiver capable of activating, receiving and interpreting an identification telegram transmitted by a transponder using either the FDX or the HDX method of transmission. However, a large population of animals has already been identified by means of transponders, in particular injectables ones, transmitting their identification telegram using one of the methods specified below. This annex specifies how this situation is to be coped with.

Clause A.2 specifies the technical characteristics of known and widely used technologies with which animals have been identified. Clause A.3 defines a concept showing how these technologies can be incorporated in a transceiver in accordance with the main body of this International Standard.

#### A.2 Technical characteristics of known and widely used technologies

A transceiver shall activate a transponder at either the frequency  $f_0$  equal to 134,2 kHz or at the optimal frequency  $f_0$  specified below.

##### A.2.1 Destron (FECVA version) technology

The transponders have been designed for optimum performance to be activated at the frequency  $f_0$  equal to  $(125 \pm 12,5 \times 10^{-3})$  kHz. The transponder sends its message using AM-FSK. The duration of a binary state shall be 100 cycles of  $f_0$ . A binary 0 is represented by 50 cycles at  $f_0/10$ , followed by 50 cycles at  $f_0/8$  (see figure A.1). A binary 1 is represented by 50 cycles at  $f_0/8$ , followed by 50 cycles at  $f_0/10$ .

The identification telegram shall comprise 48 data bits, of which 35 are information bits. The structure of the identification telegram is shown in figure A.2.

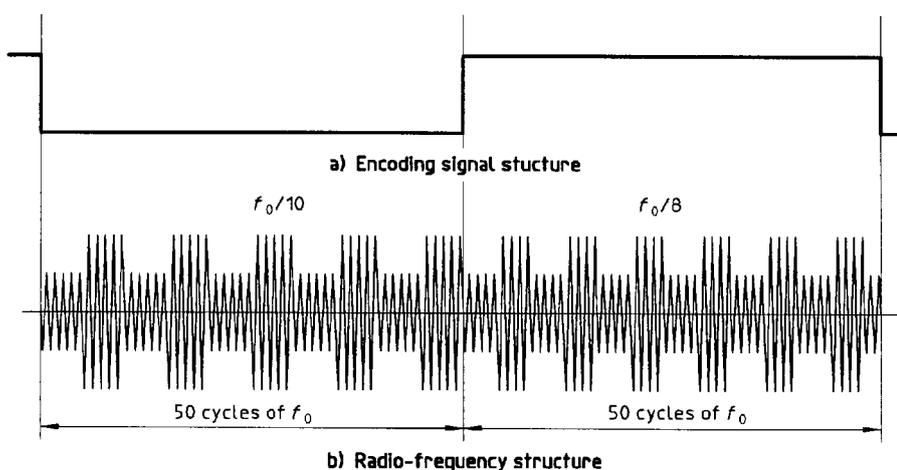

**Figure A.1 — Signal structures of binary 0 of Destron (FECVA version)**

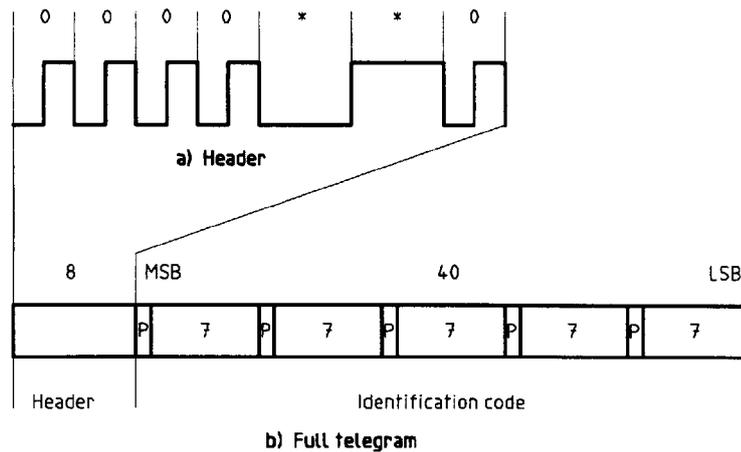

- \* Encoding violation
- P Parity data bit, odd parity check

**Figure A.2 — Structure of the Destron (FECVA version) identification telegram**

The transceiver shall validate the unique identification code after reception of at least two identical telegrams.

**A.2.2 Datamars technology**

The transponders have been designed for optimum performance to be activated at the frequency  $f_0$  equal to  $(125 \pm 12,5 \times 10^{-3})$  kHz. The transponder sends its message using PSK in the frequency band  $f_0/9$ . The duration of a binary state (equal to one bit length) is 100 cycles of  $f_0$ . The encoding of the message is Manchester. Each transition in the Manchester encoded signal is represented by a  $120^\circ$  phase shift. The Manchester transition representing a binary 0 of the original message consists of a  $-120^\circ$  phase shift and that representing a binary 1 consists of a  $+120^\circ$  phase shift.

The structure of the identification telegram (see figure A.3) comprises 62 bits as follows:

- 8 synchronization bits (0000 "1" "0" 0 where "1" and "0" are long bits which are 1,5 times longer than normal bits);
- 48 information bits, divided into 6 blocks of 8 bits [each block is supplemented with a parity (even) bit at the end].

The transceiver shall validate the unique identification code after reception of at least two identical telegrams.

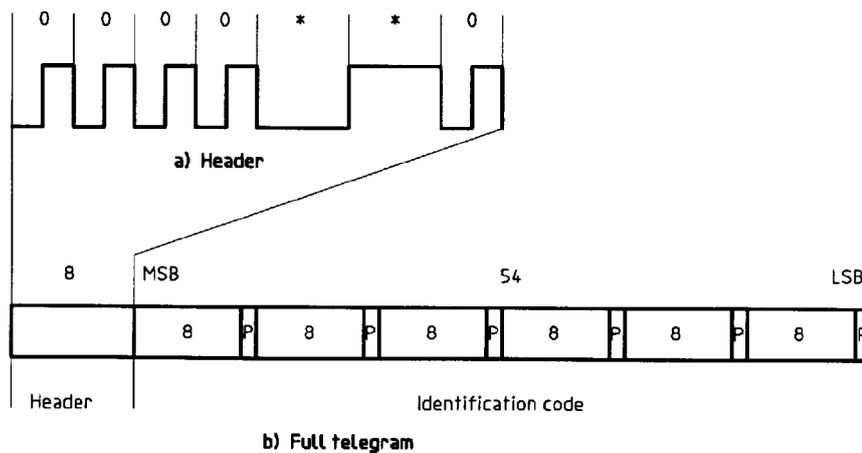

- \* Encoding violation
- P Parity data bit, even parity check

**Figure A.3 — The structure of the Datamars identification telegram**

### A.2.3 Trovan technology

The transponders have been designed for optimum performance to be activated at the frequency  $f_0$  equal to  $(128 \pm 3)$  kHz. The transponder sends its message using PSK in the frequency band  $f_0/2$ . The encoding is differential biphase. A binary 0 is represented by a phase shift of  $180^\circ$ . A binary 1 is represented by a phase shift of  $0^\circ$ . The duration of a binary state is 16 cycles of  $f_0$ .

The structure of the identification telegram (see figure A.4) comprises 64 bits as follows:

- 8 synchronization bits (01111111);
- 39 information bits;
- 17 error detection bits.

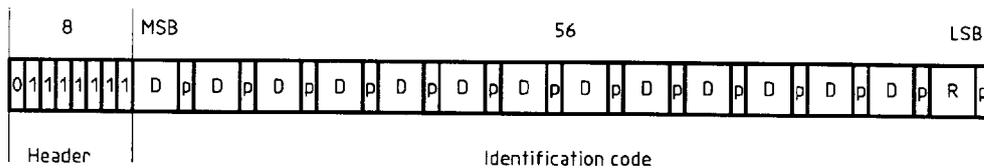

- D Data bits in groups of 3
- p Row parity, odd parity check
- R Column parity bits, odd parity check

Figure A.4 — The structure of the Trovan identification telegram

### A.3 Concept for including the technologies in an FDX/HDX transceiver

This clause recommends a concept for the inclusion of the technologies described in section A.2.1, A.2.2 and A.2.3 in a transceiver. This concept consists of plugging a module for one or more of these technologies into the receiver part of the transceiver. Figure A.5 shows the operating mode. The default function is to read the FDX/HDX signal. The transceiver shall immediately switch back to the default function after reading a transponder which is in accordance with A.2.1, A.2.2 or A.2.3.

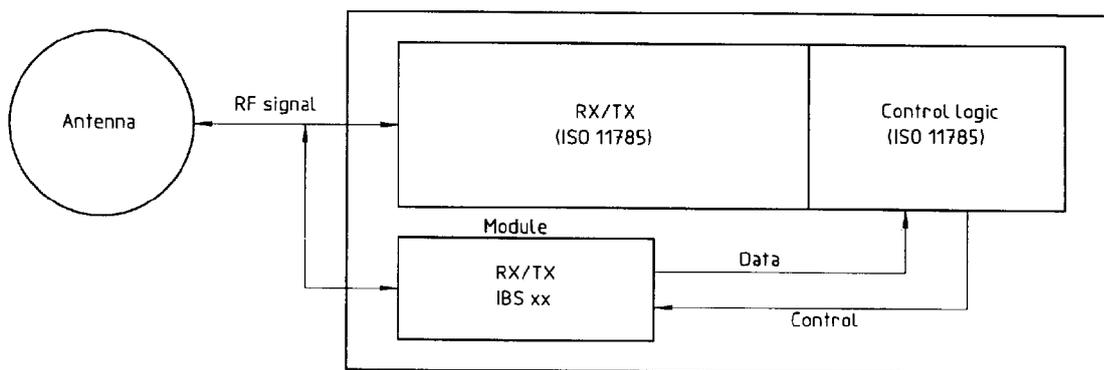

- RX Receiver
- TX Transmitter
- IBS Installed base system

Figure A.5 — Schematic diagram of a transceiver combined with a module to read one of the technologies described in this annex

## Annex B (normative)

### CRC check for error detection

#### B.1 Description

The CRC polynomial (0 x 1 021) is:

$$P(X) = X^{16} + X^{12} + X^5 + 1$$

The implemented version of the CRC check has the following characteristics:

- reverse CRC-CCITT (0 x 8 408);
- the data stream is always sent from transponder with LSB first;
- the CRC shift register is initialized to all 16 bits equal to zero;
- the first data bit (LSB data) EXORed with the LSB of the register is shifted into the register's MSB;
- after the 64 shifts (64 data bits are shifted) the register contains the BCC.

Figure B.1 shows the CRC check.

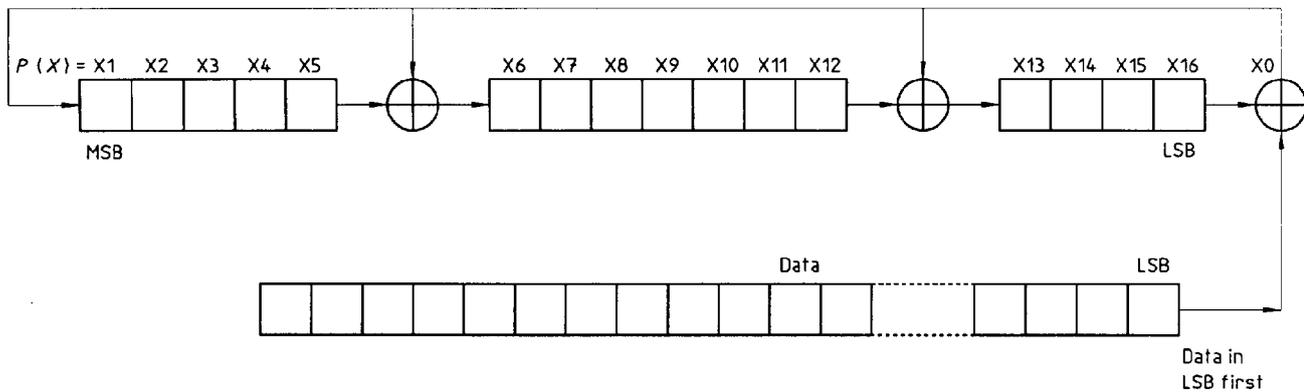

**Figure B.1 — Schematic diagram of the CRC check**

#### B.2 CRC check source code example

```

; BCCH and BCCL contain the 16 bit CRC. Both must be initialized to zero;
; GPR is a general purpose register for temporary storage (scratch register)
; A = Accumulator
; BTJZ  Bit Test Jump Zero
; SETC  Set Carry Flag
; CLRC  Clear Carry Flag
; RRC   Rotate Right Through Carry
    
```

```

; loop start
; test databit for high or low
        BTJZ   %RXDAT,DALOW      ; RXDAT=LOW
        SETC   ; RXDAT=HIGH
        JMP    BCCGEN
DALOW   CLRC
BCCGEN  RRC    BCCH              ; Shift
        RRC    BCCL
        JNC    Q1L              ; C=0
        XOR    %?10000000,BCCH  ; C=1 --> Toggle Q16
Q1L     MOV    BCCH,GPR         ; Q16=0 ?
        AND    %?10000000,GPR
        JZ     D16L
        XOR    %?00001000,BCCL  ; Toggle Q4
        XOR    %?00000100,BCCH  ; Toggle Q11
D16L   continue with Program
; repeat loop for n bits

```

### B.3 Reference

CCITT Recommendation G.706, *Frame alignment and cyclic redundancy check (CRC) procedures relating to basic frame structures defined in recommendation G.704.*

## Annex C (informative)

### Synchronization

#### C.1 Introduction

A transceiver which is in the vicinity of a second transceiver is very likely to transmit its activation signal during the listening pause of the second transceiver and vice versa. The result is that neither transceiver will be able to receive the HDX telegram. This annex indicates how transceivers, operating according to the protocol defined in ISO 11785, can be synchronized to overcome this problem.

In practice, two basic types of transceiver can be encountered: stationary and mobile. Stationary transceivers can be interconnected to synchronize activation and listening periods; mobile transceivers must be able to synchronize without connecting wires.

#### C.2 Wired synchronization

To explain the concepts, five cases will be reviewed. In these cases four transceivers (TRX1-TRX4) continuously try to activate both FDX and HDX transponders using the activation protocol described in clause 6 of this International Standard. These transceivers are interconnected and synchronized with a simple two-level signal. This synchronization signal is "low" if no transponder telegram is being received; it is "high" if one of the transceivers is receiving a telegram.

**Case 1:** None of the transceivers have transponders in the field.

**Case 2:** The TRX2 transceiver detects an HDX transponder.

Since no FDX signals appear at any of the transceivers the activation signal does not need to be extended. The presence of the HDX signal (within 3 ms) is signalled by TRX2 by making the synchronization signal "high", which causes all other transceivers to provide a listening period of 20 ms.

**Case 3:** Transceiver TRX1 detects an FDX transponder.

The transponder transmits its data telegram almost instantaneously upon receiving the activation signal. If the transponder signal was received but not validated, the activation signal can be extended until the signal is received correctly or until a 100 ms time-out period has expired. During reception, TRX1 makes the synchronization signal "high".

Since no HDX signal is received, the following pause can be limited to 3 ms for all transceivers.

**Case 4:** Transceiver TRX2 detects an HDX transponder and TRX4 an FDX transponder during the same interrogation sequence.

The FDX transponder telegram is correctly received within 50 ms; consequently, the interrogation pattern is identical to case 2.

**Case 5:** Is similar to case 4 except that validation of the FDX telegram requires extension of the activation signal.

#### C.3 Wireless synchronization

A mobile transceiver by nature cannot directly be connected to other transceivers. To prevent a mobile transceiver interfering with the interrogation protocol of other transceivers it must be able to detect the presence of additional

active transceivers through the reception of activation signals. If no activation signal is detected within 30 ms, the transceiver is out of reach of other active transceivers and its activation signal will not interfere with other interrogation processes. The transceiver can therefore safely use the protocols defined in clause 6 of this International Standard. If the mobile transceiver detects an activation signal it must wait for the rising edge of the next activation signal and activate during a fixed period of 50 ms.

In all the cases described in clause C.2, and depicted in figure C.1, the mobile transceiver will be able to receive FDX transponders. In those cases where a stationary reader forces a 20 ms listening pause it will also be able to read HDX transponders. Each tenth cycle is fixed to 50 ms activation and 20 ms pause and will enable the mobile transceiver to receive an HDX telegram, regardless of the other transceivers.

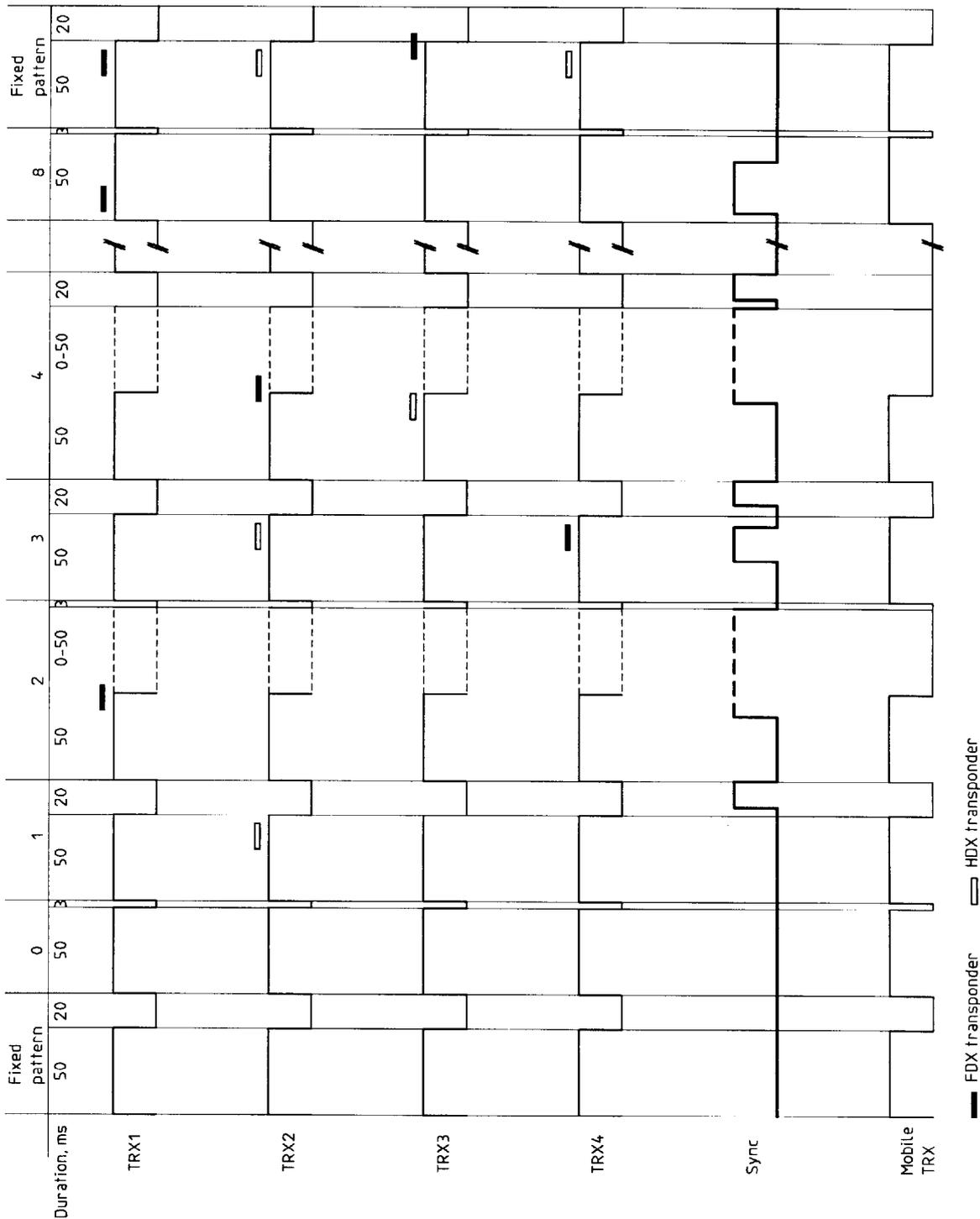

Figure C.1 — Interrogation protocol patterns

---

---

**ICS 65.040.99**

**Descriptors:** agricultural equipment, radiocommunications, electronic equipment, livestock equipment, livestock, domestic animals, identification methods, radiolocation, operating requirements, generalities.

Price based on 13 pages

---

---