

INTERNATIONAL STANDARD

ISO 11754

Second edition
2003-02-15

Space data and information transfer systems — Telemetry channel coding

*Systèmes de transfert des informations et données spatiales —
Codage de canal pour télémesure*



Reference number
ISO 11754:2003(E)

© ISO 2003

PDF disclaimer

This PDF file may contain embedded typefaces. In accordance with Adobe's licensing policy, this file may be printed or viewed but shall not be edited unless the typefaces which are embedded are licensed to and installed on the computer performing the editing. In downloading this file, parties accept therein the responsibility of not infringing Adobe's licensing policy. The ISO Central Secretariat accepts no liability in this area.

Adobe is a trademark of Adobe Systems Incorporated.

Details of the software products used to create this PDF file can be found in the General Info relative to the file; the PDF-creation parameters were optimized for printing. Every care has been taken to ensure that the file is suitable for use by ISO member bodies. In the unlikely event that a problem relating to it is found, please inform the Central Secretariat at the address given below.

© ISO 2003

All rights reserved. Unless otherwise specified, no part of this publication may be reproduced or utilized in any form or by any means, electronic or mechanical, including photocopying and microfilm, without permission in writing from either ISO at the address below or ISO's member body in the country of the requester.

ISO copyright office
Case postale 56 • CH-1211 Geneva 20
Tel. + 41 22 749 01 11
Fax + 41 22 749 09 47
E-mail copyright@iso.org
Web www.iso.org

Published in Switzerland

Foreword

ISO (the International Organization for Standardization) is a worldwide federation of national standards bodies (ISO member bodies). The work of preparing International Standards is normally carried out through ISO technical committees. Each member body interested in a subject for which a technical committee has been established has the right to be represented on that committee. International organizations, governmental and non-governmental, in liaison with ISO, also take part in the work. ISO collaborates closely with the International Electrotechnical Commission (IEC) on all matters of electrotechnical standardization.

International Standards are drafted in accordance with the rules given in the ISO/IEC Directives, Part 2.

The main task of technical committees is to prepare International Standards. Draft International Standards adopted by the technical committees are circulated to the member bodies for voting. Publication as an International Standard requires approval by at least 75 % of the member bodies casting a vote.

Attention is drawn to the possibility that some of the elements of this document may be the subject of patent rights. ISO shall not be held responsible for identifying any or all such patent rights.

International Standard ISO 11754 was prepared by the Consultative Committee for Space Data Systems (CCSDS) (as CCSDS 101.0-B-5, June 2001) and was adopted (without modifications except those stated in Clause 2 of this International Standard) by Technical Committee ISO/TC 20, *Aircraft and space vehicles*, Subcommittee SC 13, *Space data and information transfer systems*.

This second edition cancels and replaces the first edition (ISO 11754:1994), which has been technically revised.

.....

Space data and information transfer systems — Telemetry channel coding

1 Scope

This International Standard specifies the requirements for telemetry channel coding of space data and information transfer systems used in civil space applications.

The scope and field of application are furthermore detailed in subclauses 1.2 and 1.3 of the enclosed CCSDS publication.

2 Requirements

Requirements are the technical recommendations made in the following publication (reproduced on the following pages), which is adopted as an International Standard:

CCSDS 101.0-B-5, June 2001, *Recommendation for space data system standards — Telemetry channel coding*.

For the purposes of international standardization, the modifications outlined below shall apply to the specific clauses and paragraphs of publication CCSDS 101.0-B-5.

Pages i to v

This part is information which is relevant to the CCSDS publication only.

Page 1-3

Add the following information to the references indicated:

[1] Document CCSDS 102.0-B-5, November 2000, is equivalent to ISO 13419:2003.

[2] Document CCSDS 701.0-B-3, June 2001, is equivalent to ISO 13420:—¹).

3 Revision of publication CCSDS 101.0-B-5

It has been agreed with the Consultative Committee for Space Data Systems that Subcommittee ISO/TC 20/SC 13 will be consulted in the event of any revision or amendment of publication CCSDS 101.0-B-5. To this end, NASA will act as a liaison body between CCSDS and ISO.

1) To be published. (Revision of ISO 13420:1997)

(Blank page)

***Consultative
Committee for
Space Data Systems***

RECOMMENDATION FOR SPACE
DATA SYSTEM STANDARDS

**TELEMETRY
CHANNEL CODING**

CCSDS 101.0-B-5

BLUE BOOK

June 2001

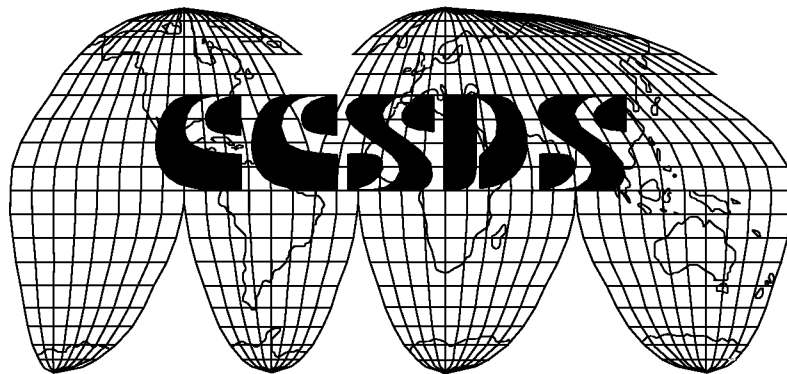

DEDICATION

This document is dedicated to the memory of Mr. Warner H. Miller of NASA. Warner had been with the CCSDS since its beginning and throughout the years he was a major contributor to numerous standards for error control coding, radio frequency modulation, data architecture, and data compression. Warner was a superb technologist, a gentleman, and a friend always ready to help, especially young colleagues. Warner and his approach to work and life in general will be deeply missed by his many friends and colleagues in the CCSDS.

CCSDS RECOMMENDATION FOR TELEMETRY CHANNEL CODING

AUTHORITY

Issue:	Blue Book, Issue 5
Date:	June 2001
Location:	Oxfordshire, UK

This document has been approved for publication by the Management Council of the Consultative Committee for Space Data Systems (CCSDS) and represents the consensus technical agreement of the participating CCSDS Member Agencies. The procedure for review and authorization of CCSDS Recommendations is detailed in reference [D1], and the record of Agency participation in the authorization of this document can be obtained from the CCSDS Secretariat at the address below.

This Recommendation is published and maintained by:

CCSDS Secretariat
Program Integration Division (Code MT)
National Aeronautics and Space Administration
Washington, DC 20546, USA

CCSDS RECOMMENDATION FOR TELEMETRY CHANNEL CODING

STATEMENT OF INTENT

The Consultative Committee for Space Data Systems (CCSDS) is an organization officially established by the management of member space Agencies. The Committee meets periodically to address data systems problems that are common to all participants, and to formulate sound technical solutions to these problems. Inasmuch as participation in the CCSDS is completely voluntary, the results of Committee actions are termed **Recommendations** and are not considered binding on any Agency.

This **Recommendation** is issued by, and represents the consensus of, the CCSDS Plenary body. Agency endorsement of this **Recommendation** is entirely voluntary. Endorsement, however, indicates the following understandings:

- o Whenever an Agency establishes a CCSDS-related **standard**, this **standard** will be in accord with the relevant **Recommendation**. Establishing such a **standard** does not preclude other provisions which an Agency may develop.
- o Whenever an Agency establishes a CCSDS-related **standard**, the Agency will provide other CCSDS member Agencies with the following information:
 - The **standard** itself.
 - The anticipated date of initial operational capability.
 - The anticipated duration of operational service.
- o Specific service arrangements shall be made via memoranda of agreement. Neither this **Recommendation** nor any ensuing **standard** is a substitute for a memorandum of agreement.

No later than five years from its date of issuance, this **Recommendation** will be reviewed by the CCSDS to determine whether it should: (1) remain in effect without change; (2) be changed to reflect the impact of new technologies, new requirements, or new directions; or, (3) be retired or canceled.

In those instances when a new version of a **Recommendation** is issued, existing CCSDS-related Agency standards and implementations are not negated or deemed to be non-CCSDS compatible. It is the responsibility of each Agency to determine when such standards or implementations are to be modified. Each Agency is, however, strongly encouraged to direct planning for its new standards and implementations towards the later version of the **Recommendation**.

CCSDS RECOMMENDATION FOR TELEMETRY CHANNEL CODING

FOREWORD

This document is a technical Recommendation for use in developing channel coding systems and has been prepared by the Consultative Committee for Space Data Systems (CCSDS). The telemetry channel coding concept described herein is the baseline concept for spacecraft-to-ground data communication within missions that are cross-supported between Agencies of the CCSDS.

This Recommendation establishes a common framework and provides a common basis for the coding schemes used on spacecraft telemetry streams. It allows implementing organizations within each Agency to proceed coherently with the development of compatible derived Standards for the flight and ground systems that are within their cognizance. Derived Agency Standards may implement only a subset of the optional features allowed by the Recommendation and may incorporate features not addressed by the Recommendation.

Through the process of normal evolution, it is expected that expansion, deletion, or modification of this document may occur. This Recommendation is therefore subject to CCSDS document management and change control procedures as defined in reference [D1]. Current versions of CCSDS documents are maintained at the CCSDS Web site:

<http://www.ccsds.org/>

Questions relating to the contents or status of this document should be addressed to the CCSDS Secretariat at the address indicated on page i.

CCSDS RECOMMENDATION FOR TELEMETRY CHANNEL CODING

At time of publication, the active Member and Observer Agencies of the CCSDS were:

Member Agencies

- Agenzia Spaziale Italiana (ASI)/Italy.
- British National Space Centre (BNSC)/United Kingdom.
- Canadian Space Agency (CSA)/Canada.
- Centre National d'Etudes Spatiales (CNES)/France.
- Deutsches Zentrum für Luft- und Raumfahrt e.V. (DLR)/Germany.
- European Space Agency (ESA)/Europe.
- Instituto Nacional de Pesquisas Espaciais (INPE)/Brazil.
- National Aeronautics and Space Administration (NASA)/USA.
- National Space Development Agency of Japan (NASDA)/Japan.
- Russian Space Agency (RSA)/Russian Federation.

Observer Agencies

- Austrian Space Agency (ASA)/Austria.
- Central Research Institute of Machine Building (TsNIIMash)/Russian Federation.
- Centro Tecnico Aeroespacial (CTA)/Brazil.
- Chinese Academy of Space Technology (CAST)/China.
- Commonwealth Scientific and Industrial Research Organization (CSIRO)/Australia.
- Communications Research Centre (CRC)/Canada.
- Communications Research Laboratory (CRL)/Japan.
- Danish Space Research Institute (DSRI)/Denmark.
- European Organization for the Exploitation of Meteorological Satellites (EUMETSAT)/Europe.
- European Telecommunications Satellite Organization (EUTELSAT)/Europe.
- Federal Service of Scientific, Technical & Cultural Affairs (FSST&CA)/Belgium.
- Hellenic National Space Committee (HNSC)/Greece.
- Indian Space Research Organization (ISRO)/India.
- Institute of Space and Astronautical Science (ISAS)/Japan.
- Institute of Space Research (IKI)/Russian Federation.
- KFKI Research Institute for Particle & Nuclear Physics (KFKI)/Hungary.
- MIKOMTEK: CSIR (CSIR)/Republic of South Africa.
- Korea Aerospace Research Institute (KARI)/Korea.
- Ministry of Communications (MOC)/Israel.
- National Oceanic & Atmospheric Administration (NOAA)/USA.
- National Space Program Office (NSPO)/Taipei.
- Swedish Space Corporation (SSC)/Sweden.
- United States Geological Survey (USGS)/USA.

CCSDS RECOMMENDATION FOR TELEMETRY CHANNEL CODING

DOCUMENT CONTROL

Document		Date	Status and Substantive Changes
CCSDS 101.0-B-1	Telemetry Channel Coding, Issue 1	May 1984	Original Issue
CCSDS 101.0-B-2	Telemetry Channel Coding, Issue 2	January 1987	<ol style="list-style-type: none"> 1. Supersedes Issue 1. 2. Removes ASM from R-S encoded data space. 3. Specifies marker pattern for ASM. 4. Transfers Annex A (“Rationale”) to Green Book.
CCSDS 101.0-B-3	Telemetry Channel Coding, Issue 3	May 1992	<ol style="list-style-type: none"> 1. Supersedes Issue 2. 2. Deletes Section 3 (“Convolutional Coding with Interleaving for Tracking and Data Relay Satellite Operations”). 3. Adds R-S interleave depths of I=2,3,4 to existing I=1 and 5. 4. Allows R-S code to be operated in “Standalone Mode” (i.e., not concatenated with the convolutional code). 5. Consolidates codeblock and transfer frame sync specifications (new Section 5). 6. Specifies a standard Pseudo-Randomizer to improve bit synchronization (new Section 6). 7. Corrects several editorial errors.
CCSDS 101.0-B-4	Telemetry Channel Coding, Issue 4	May 1999	<ol style="list-style-type: none"> 1. Supersedes Issue 3. 2. Adds turbo code specification (new Section 4). 3. Moves normative references from front matter to Section 1. 4. Moves informative references to Annex D.
CCSDS 101.0-B-5	Telemetry Channel Coding, Issue 5	June 2001	<ol style="list-style-type: none"> 1. Supersedes Issue 4. 2. Corrects misleading encoder diagrams. 3. Adds the following options to help near-earth users: <ul style="list-style-type: none"> – Reed-Solomon 8-error correcting code; – a set of punctured convolutional codes comparable to the DVB-S standard. 4. Specifies maximum frame lengths.

NOTE – Substantive technical changes from the previous issue are flagged with change bars in the right margin.

CONTENTS

<u>Section</u>	<u>Page</u>
1 INTRODUCTION	1-1
1.1 PURPOSE	1-1
1.2 SCOPE	1-1
1.3 APPLICABILITY	1-2
1.4 BIT NUMBERING CONVENTION AND NOMENCLATURE.....	1-2
1.5 RATIONALE	1-3
1.6 REFERENCES.....	1-3
2 CONVOLUTIONAL CODING	2-1
2.1 BASIC CONVOLUTIONAL CODE	2-1
2.2 PUNCTURED CONVOLUTIONAL CODES	2-4
3 REED-SOLOMON CODING	3-1
3.1 INTRODUCTION.....	3-1
3.2 SPECIFICATION	3-1
4 TURBO CODING	4-1
4.1 INTRODUCTION.....	4-1
4.2 SPECIFICATION	4-2
5 FRAME SYNCHRONIZATION	5-1
5.1 INTRODUCTION.....	5-1
5.2 THE ATTACHED SYNC MARKER (ASM)	5-1
5.3 ASM BIT PATTERNS	5-1
5.4 LOCATION OF ASM.....	5-3
5.5 RELATIONSHIP OF ASM TO REED-SOLOMON AND TURBO CODEBLOCKS	5-3
5.6 ASM FOR EMBEDDED DATA STREAM.....	5-3
6 PSEUDO-RANDOMIZER	6-1
6.1 INTRODUCTION.....	6-1
6.2 PSEUDO-RANDOMIZER DESCRIPTION	6-1
6.3 SYNCHRONIZATION AND APPLICATION OF PSEUDO-RANDOMIZER....	6-2
6.4 SEQUENCE SPECIFICATION.....	6-2
6.5 LOGIC DIAGRAM.....	6-2

CCSDS RECOMMENDATION FOR TELEMETRY CHANNEL CODING

CONTENTS (continued)

<u>Section</u>	<u>Page</u>
ANNEX A TRANSFORMATION BETWEEN BERLEKAMP AND CONVENTIONAL REPRESENTATIONS	A-1
ANNEX B EXPANSION OF REED-SOLOMON COEFFICIENTS	B-1
ANNEX C GLOSSARY OF ACRONYMS AND TERMS	C-1
ANNEX D INFORMATIVE REFERENCES.....	D-1
ANNEX E COMPATIBLE FRAME LENGTHS FOR CCSDS CODEBLOCKS.....	E-1

Figure

1-1 Bit Numbering.....	1-2
2-1 Convolutional Encoder Block Diagram	2-3
2-2 Punctured Encoder Block Diagram	2-4
3-1 Functional Representation of R-S Interleaving	3-3
3-2 Reed-Solomon Codeblock Partitioning.....	3-5
4-1 Interpretation of Permutation	4-4
4-2 Turbo Encoder Block Diagram	4-5
4-3 Turbo Codeblocks for Different Code Rates.....	4-7
4-4 Turbo Codeblock with Attached Sync Marker.....	4-8
5-1 ASM Bit Pattern for Non-Turbo-Coded Data	5-2
5-2 ASM Bit Pattern for Turbo-Coded Data	5-2
5-3 Embedded ASM Bit Pattern.....	5-3
6-1 Pseudo-Randomizer Configuration	6-1
6-2 Pseudo-Randomizer Logic Diagram	6-3
A-1 Transformational Equivalence	A-2

Table

2-1 Puncture Code Patterns for Convolutional Code Rates	2-5
4-1 Specified Information Block Lengths	4-2
4-2 Codeblock Lengths for Supported Code Rates (Measured in Bits)	4-3
4-3 Parameters k_1 and k_2 for Specified Information Block Lengths.....	4-4
A-1 Equivalence of Representations	A-5

(Blank page)

.....

CCSDS RECOMMENDATION FOR TELEMETRY CHANNEL CODING

1 INTRODUCTION

1.1 PURPOSE

The purpose of this document is to establish a common Recommendation for space telemetry channel coding systems to provide cross-support among missions and facilities of member Agencies of the Consultative Committee for Space Data Systems (CCSDS). In addition, it provides focusing for the development of multi-mission support capabilities within the respective Agencies to eliminate the need for arbitrary, unique capabilities for each mission.

Telemetry channel coding is a method of processing data being sent from a source to a destination so that distinct messages are created which are easily distinguishable from one another. This allows reconstruction of the data with low error probability, thus improving the performance of the channel.

1.2 SCOPE

Several space telemetry channel coding schemes are described in this document. The characteristics of the codes are specified only to the extent necessary to ensure interoperability and cross-support. The specification does not attempt to quantify the relative coding gain or the merits of each approach discussed, nor the design requirements for encoders or decoders. Some performance information is included in Reference [D2].

This Recommendation does not require that coding be used on all cross-supported missions. However, for those planning to use coding, the recommended codes to be used are those described in this document.

The rate 1/2 convolutional code recommended for cross-support is described in Section 2, "Convolutional Coding". Depending on performance requirements, this code alone may be satisfactory.

For telecommunication channels which are bandwidth-constrained and cannot tolerate the increase in bandwidth required by the basic convolutional code specified in 2.1, the punctured convolutional code specified in 2.2 has the advantage of smaller bandwidth expansion. The Reed-Solomon code specified in Section 3 also has the advantage of smaller bandwidth expansion and has the capability to indicate the presence of uncorrectable errors.

Where a greater coding gain is needed than can be provided by the convolutional code or Reed-Solomon code alone, a concatenation of the convolutional code as the inner code with the Reed-Solomon code as the outer code may be used for improved performance. The turbo codes recommended in Section 4 may be used to obtain even greater coding gain where the environment permits.

The recommended methods for frame (or codeblock) synchronization are described in Section 5.

CCSDS RECOMMENDATION FOR TELEMETRY CHANNEL CODING

To improve bit transition density as an aid to bit synchronization, a recommended method of pseudo-randomizing data to be sent over the telemetry channel is described in Section 6.

Annex A provides a discussion of the transformation between the Berlekamp and conventional Reed-Solomon symbol representations; Annex B provides a table showing the expansion of Reed-Solomon coefficients; and Annex C is a glossary of coding terminology used in this document.

1.3 APPLICABILITY

This Recommendation applies to telemetry channel coding applications of space missions anticipating cross-support among CCSDS member Agencies at the coding layer. In addition, it serves as a guideline for the development of compatible internal Agency Standards in this field, based on good engineering practice.

In addition to being applicable to conventional Packet Telemetry systems [1], the codes in this recommendation are applicable to the forward and return links of Advanced Orbiting Systems (AOS) [2]. For coding purposes, the terms “Transfer Frame” and “Reed-Solomon Codeblock” as used in this recommendation are understood to be equivalent to the AOS terms “Virtual Channel Data Unit” (VCDU), and “Coded Virtual Channel Data Unit” (CVCDU), respectively.

1.4 BIT NUMBERING CONVENTION AND NOMENCLATURE

In this document, the following convention is used to identify each bit in a forward-justified *N*-bit field. The first bit in the field to be transmitted (i.e., the most left justified when drawing a figure) is defined to be “Bit 0”; the following bit is defined to be “Bit 1” and so on up to “Bit *N*-1”, as shown in Figure 1-1. When the field is used to express a binary value (such as a counter), the Most Significant Bit (MSB) shall be the first transmitted bit of the field, i.e., “Bit 0”.

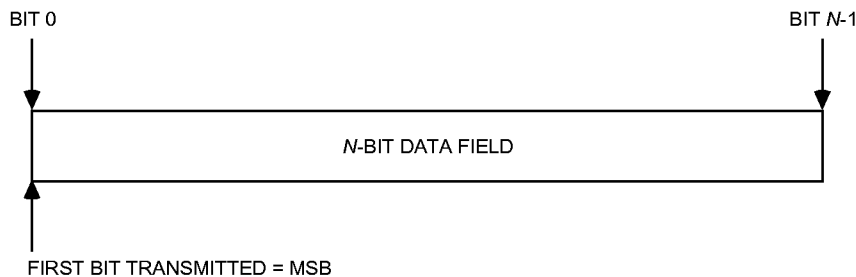

Figure 1-1: Bit Numbering

CCSDS RECOMMENDATION FOR TELEMETRY CHANNEL CODING

In accordance with modern data communications practice, spacecraft data fields are often grouped into 8-bit “words” which conform to the above convention. Throughout this Recommendation, the following nomenclature is used to describe this grouping:

8-BIT WORD = “OCTET”

1.5 RATIONALE

The CCSDS believes it is important to document the rationale underlying the standards chosen, so that future evaluations of proposed changes or improvements will not lose sight of previous decisions. The concept and rationale for Telemetry Channel Coding may be found in Reference [D2].

1.6 REFERENCES

The following documents are referenced in this Recommendation. At the time of publication, the editions indicated were valid. All documents are subject to revision, and users of this Recommendation are encouraged to investigate the possibility of applying the most recent editions of the documents indicated below. The CCSDS Secretariat maintains a register of currently valid CCSDS Recommendations.

- [1] *Packet Telemetry*. Recommendation for Space Data System Standards, CCSDS 102.0-B-5. Blue Book. Issue 5. Washington, D.C.: CCSDS, November 2000.
- [2] *Advanced Orbiting Systems, Networks and Data Links: Architectural Specification*. Recommendation for Space Data System Standards, CCSDS 701.0-B-3. Blue Book. Issue 3. Washington, D.C.: CCSDS, June 2001.
- [3] Recommendation 2.4.9, “Minimum Modulated Symbol Transition Density on the Space-to-Earth Link” in *Radio Frequency and Modulation Systems—Part 1: Earth Stations and Spacecraft*. Recommendations for Space Data System Standards, CCSDS 401.0-B. Blue Book. Washington, D.C.: CCSDS, June 2001.

(Blank page)

CCSDS RECOMMENDATION FOR TELEMETRY CHANNEL CODING

2 CONVOLUTIONAL CODING**2.1 BASIC CONVOLUTIONAL CODE****2.1.1 BASIC CONVOLUTIONAL CODE DESCRIPTION**

The basic convolutional code is a rate $1/2$, constraint-length 7 transparent code which is well suited for channels with predominantly Gaussian noise. This code is defined in 2.1.2. When this code is punctured according to 2.2, higher code rates (lower overhead) may be achieved, although with somewhat lower error correcting performance.

The convolutional decoder is a maximum-likelihood (Viterbi) decoder.

NOTES

- 1 Basic convolutional code, by itself, cannot guarantee sufficient symbol transitions when multiplexing schemes are used, e.g., those implemented in QPSK. Unless sufficient symbol transition density is assured by other means, the Pseudo-randomizer defined in section 6 is required.
- 2 If the decoder's correction capability is exceeded, undetected burst errors may appear in the output. For this reason, when CCSDS Transfer Frames or Virtual Channel Data Units are used, references [1] and [2], respectively, require that a cyclic redundancy check (CRC) be used to validate the frame unless the Reed-Solomon code is used.

It is recommended that soft bit decisions with at least 3-bit quantization be used whenever constraints (such as location of decoder) permit.

CCSDS RECOMMENDATION FOR TELEMETRY CHANNEL CODING

2.1.2 BASIC CONVOLUTIONAL CODE SPECIFICATION

This recommendation is a non-systematic code and a specific decoding procedure, with the following characteristics:¹

- (1) Nomenclature: Convolutional code with maximum-likelihood (Viterbi) decoding.
- (2) Code rate: 1/2 bit per symbol.
- (3) Constraint length: 7 bits.
- (4) Connection vectors: $G1 = 1111001$ (171 octal); $G2 = 1011011$ (133 octal).
- (5) Symbol inversion: On output path of $G2$.

An encoder block diagram is shown in Figure 2-1.

The output symbol sequence is: $C_1(1), \overline{C_2(1)}, C_1(2), \overline{C_2(2)}, \dots$

¹ When suppressed-carrier modulation systems are used, NRZ-M or NRZ-L may be used as a modulating waveform. If the user contemplates conversion of his modulating waveform from NRZ-L to NRZ-M, such conversion should be performed on-board at the input to the convolutional encoder. Correspondingly, the conversion on the ground from NRZ-M to NRZ-L should be performed at the output of the convolutional decoder. This avoids unnecessary link performance loss.

CAUTION – When a fixed pattern (the fixed part of the convolutionally encoded Attached Sync Marker) in the symbol stream is used to provide node synchronization for the Viterbi decoder, care must be taken to account for any modification of the pattern due to the modulating waveform conversion.

CCSDS RECOMMENDATION FOR TELEMETRY CHANNEL CODING

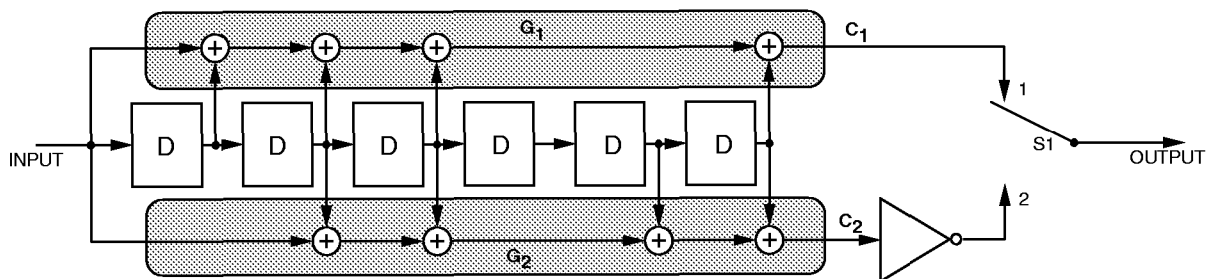

NOTES:



1.  = SINGLE BIT DELAY.
2. FOR EVERY INPUT BIT, TWO SYMBOLS ARE GENERATED BY COMPLETION OF A CYCLE FOR S1: POSITION 1, POSITION 2.
3. S1 IS IN THE POSITION SHOWN (1) FOR THE FIRST SYMBOL ASSOCIATED WITH AN INCOMING BIT.
4.  = MODULO-2 ADDER.
5.  = INVERTER.

Figure 2-1: Convolutional Encoder Block Diagram

2.2 PUNCTURED CONVOLUTIONAL CODES

2.2.1 GENERAL

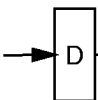
The code rate ($r=1/2$), constraint length ($k=7$) convolutional code can be modified to achieve an increase in bandwidth efficiency. This modification is achieved by using a puncture pattern $P(r)$. Puncturing removes some of the symbols before transmission, providing lower overhead and lower bandwidth expansion than the original code, but with slightly reduced error correcting performance.

2.2.2 PUNCTURED CONVOLUTIONAL CODES DESCRIPTION

Puncturing allows a single code rate of either $2/3$, $3/4$, $5/6$ or $7/8$ to be selected. The four different puncturing schemes allow selection of the most appropriate level of error correction and symbol rate for a given service or data rate. Figure 2-2 depicts the punctured encoding scheme.

NOTE – The symbol inverter associated with G_2 in the rate $1/2$ code (defined in 2.1.2) is omitted here. If sufficient symbol transition density is not ensured by other means then the Pseudo-randomizer defined in section 6 is required.

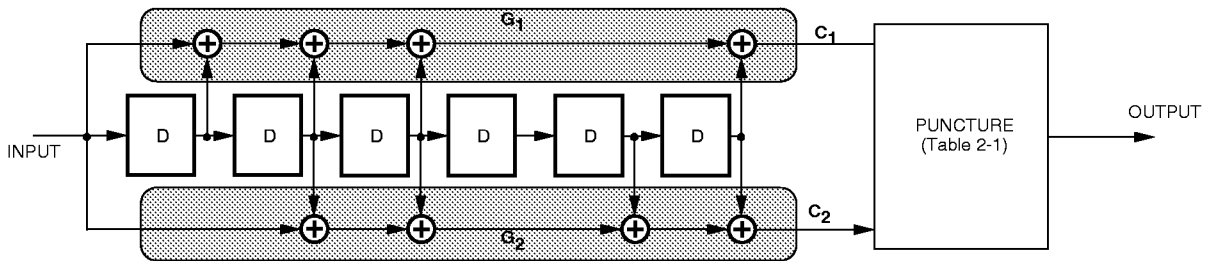

Figure 2-2: Punctured Encoder Block Diagram

CCSDS RECOMMENDATION FOR TELEMETRY CHANNEL CODING

2.2.3 PUNCTURED CONVOLUTIONAL CODES SPECIFICATION

The punctured convolutional code has the following characteristics:

- (1) Nomenclature: Punctured convolutional code with maximum-likelihood (Viterbi) decoding.
- (2) Code rate: $1/2$, punctured to $2/3$, $3/4$, $5/6$ or $7/8$
- (3) Constraint length: 7 bits
- (4) Connection vectors: $G1 = 1111001$ (171 octal); $G2 = 1011011$ (133 octal)
- (5) Symbol inversion: None

The puncturing patterns for each of the punctured convolutional code rates are defined by Table 2-1 below.

Table 2-1: Puncture Code Patterns for Convolutional Code Rates

Puncturing Pattern 1 = transmitted symbol 0 = non-transmitted symbol	Code Rate	Output Sequence $C_1(t), C_2(t)$ denote values at bit time t
$C_1: 10$ $C_2: 11$	$2/3$	$C_1(1) C_2(1) C_2(2) \dots$
$C_1: 101$ $C_2: 110$	$3/4$	$C_1(1) C_2(1) C_2(2) C_1(3) \dots$
$C_1: 10101$ $C_2: 11010$	$5/6$	$C_1(1) C_2(1) C_2(2) C_1(3) C_2(4) C_1(5) \dots$
$C_1: 1000101$ $C_2: 1111010$	$7/8$	$C_1(1) C_2(1) C_2(2) C_2(3) C_2(4) C_1(5) C_2(6) C_1(7) \dots$

(Blank page)

.....

CCSDS RECOMMENDATION FOR TELEMETRY CHANNEL CODING

3 REED-SOLOMON CODING

3.1 INTRODUCTION

The Reed-Solomon code defined in this section is a powerful burst error correcting code. In addition, the code chosen has an extremely low undetected error rate. This means that the decoder can reliably indicate whether it can make the proper corrections or not. To achieve this reliability, proper codeblock synchronization is mandatory.

One of two different error-correcting options may be chosen. For maximum performance (at the expense of accompanying overhead) the $E=16$ option can correct 16 R-S symbols in error per codeword. For lower overhead (with reduced performance) the $E=8$ option can correct 8 R-S symbols per codeword. The two options shall not be mixed in a single telemetry stream.

NOTES

- 1 The extremely low undetected error rate of this code means that the R-S decoder can, with a high degree of certainty, validate the decoded codeblock and consequently the contained CCSDS Transfer Frame (reference [1]) or Virtual Channel Data Unit (reference [2]). For this reason, [1] and [2] do not require a Cyclic Redundancy Check when this Reed-Solomon Code is used.
- 2 The Reed-Solomon coding, by itself, cannot guarantee sufficient channel symbol transitions to keep receiver symbol synchronizers in lock. Unless sufficient channel symbol transition density is ensured by other means, the Pseudo-randomizer defined in section 6 is required.

The Reed-Solomon code may be used alone, and as such it provides an excellent forward error correction capability in a burst-noise channel. However, should the Reed-Solomon code alone not provide sufficient coding gain, it may be concatenated with the convolutional code defined in Section 2. Used this way, the Reed-Solomon code is the *outer code*, while the convolutional code is the *inner code*.

3.2 SPECIFICATION

The parameters of the selected Reed-Solomon (R-S) code are as follows:

- (1) $J = 8$ bits per R-S symbol.
- (2) $E =$ Reed-Solomon error correction capability, in symbols, within an R-S codeword. E may be selected to be 16 or 8 R-S symbols.
- (3) General characteristics of the Reed-Solomon code:

CCSDS RECOMMENDATION FOR TELEMETRY CHANNEL CODING

- (a) J , E , and I (the depth of interleaving) are independent parameters.
- (b) $n = 2^J - 1 = 255$ symbols per R-S codeword.
- (c) $2E$ is the number of R-S symbols among n symbols of an R-S codeword representing parity checks.
- (d) $k = n - 2E$ is the number of R-S symbols among n R-S symbols of an R-S codeword representing information.

(4) Field generator polynomial:

$$F(x) = x^8 + x^7 + x^2 + x + 1$$

over GF(2).

(5) Code generator polynomial:

$$g(x) = \prod_{j=128-E}^{127+E} (x - \alpha^{11j}) = \sum_{i=0}^{2E} G_i x^i$$

over GF(2⁸), where F(α) = 0.

It should be recognized that α¹¹ is a primitive element in GF(2⁸) and that F(x) and g(x) characterize a (255,223) Reed-Solomon code when E = 16 and a (255,239) Reed-Solomon code when E = 8.

- (6) The selected code is a systematic code. This results in a systematic codeblock.
- (7) Symbol Interleaving:

The allowable values of interleaving depth are I=1, 2, 3, 4, and 5. I=1 is equivalent to the absence of interleaving. The interleaving depth shall normally be fixed on a physical channel for a mission. Symbol interleaving is accomplished in a manner functionally described with the aid of Figure 3-1. (It should be noted that this functional description does not necessarily correspond to the physical implementation of an encoder.)

CCSDS RECOMMENDATION FOR TELEMETRY CHANNEL CODING

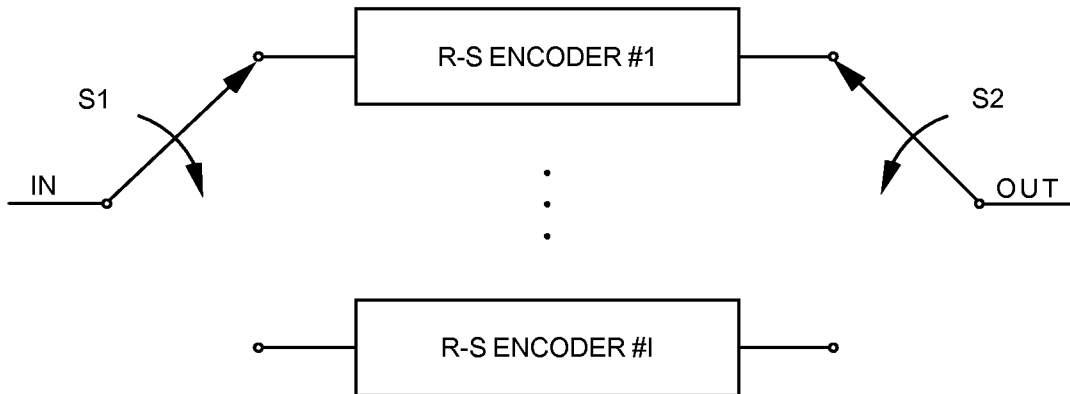

Figure 3-1: Functional Representation of R-S Interleaving

Data bits to be encoded into a single Reed-Solomon Codeblock enter at the port labeled “IN”. Switches S1 and S2 are synchronized together and advance from encoder to encoder in the sequence 1,2, . . . , I, 1,2, . . . , I, . . . , spending one R-S symbol time (8 bits) in each position.

One codeblock will be formed from kI R-S symbols entering “IN”. In this functional representation, a space of $2EI$ R-S symbols in duration is required between each entering set of kI R-S information symbols.

Due to the action of S1, each encoder accepts k of these symbols, each symbol spaced I symbols apart (in the original stream). These k symbols are passed directly to the output of each encoder. The synchronized action of S2 reassembles the symbols at the port labeled “OUT” in the same way as they entered at “IN”.

Following this, each encoder outputs its $2E$ check symbols, one symbol at a time, as it is sampled in sequence by S2.

If, for $I=5$, the original symbol stream is

$$d_1^1 \dots d_1^5 d_2^1 \dots d_2^5 \dots d_k^1 \dots d_k^5 \quad [2E \times 5 \text{ spaces}]$$

then the output is the same sequence with the $[2E \times 5 \text{ spaces}]$ filled by the $[2E \times 5]$ check symbols as shown below:

$$p_1^1 \dots p_1^5 \dots p_{2E}^1 \dots p_{2E}^5$$

where

$$d_1^i d_2^i \dots d_k^i p_1^i \dots p_{2E}^i$$

CCSDS RECOMMENDATION FOR TELEMETRY CHANNEL CODING

is the R-S codeword produced by the i th encoder. If q virtual fill symbols are used in each codeword, then replace k by $(k - q)$ in the above discussion.

With this method of interleaving, the original kI consecutive information symbols that entered the encoder appear unchanged at the output of the encoder with $2EI$ R-S check symbols appended.

(8) Maximum Codeblock Length:

The maximum codeblock length, in R-S symbols, is given by:

$$L_{\max} = nI = (2^J - 1)I = 255I$$

(9) Shortened Codeblock Length:¹

A shortened codeblock length may be used to accommodate frame lengths smaller than the maximum. However, since the Reed-Solomon code is a block code, the decoder must always operate on a full block basis. To achieve a full codeblock, "virtual fill" must be added to make up the difference between the shortened block and the maximum codeblock length. The characteristics and limitations of virtual fill are covered in paragraph (10). Since the virtual fill is not transmitted, both encoder and decoder must be set to insert it with the proper length for the encoding and decoding processes to be carried out properly.

When an encoder (initially cleared at the start of a block) receives $kI - Q$ symbols representing information (where Q , representing fill, is a multiple of I , and is less than kI), $2EI$ check symbols are computed over kI symbols, of which the leading Q symbols are treated as all-zero symbols. A $(nI - Q, kI - Q)$ shortened codeblock results where the leading Q symbols (all zeros) are neither entered into the encoder nor transmitted.

(10) Reed-Solomon Codeblock Partitioning and Virtual Fill:

The R-S codeblock is partitioned as shown in Figure 3-2.

¹ It should be noted that shortening the transmitted codeblock length in this way changes the overall performance to a degree dependent on the amount of virtual fill used. Since it incorporates no virtual fill, the maximum codeblock length allows full performance. In addition, as virtual fill in a codeblock is increased (at a specific bit rate), the number of codeblocks per unit time that the decoder must handle increases. Therefore, care should be taken so that the maximum operating speed of the decoder (codeblocks per unit time) is not exceeded.

CCSDS RECOMMENDATION FOR TELEMETRY CHANNEL CODING

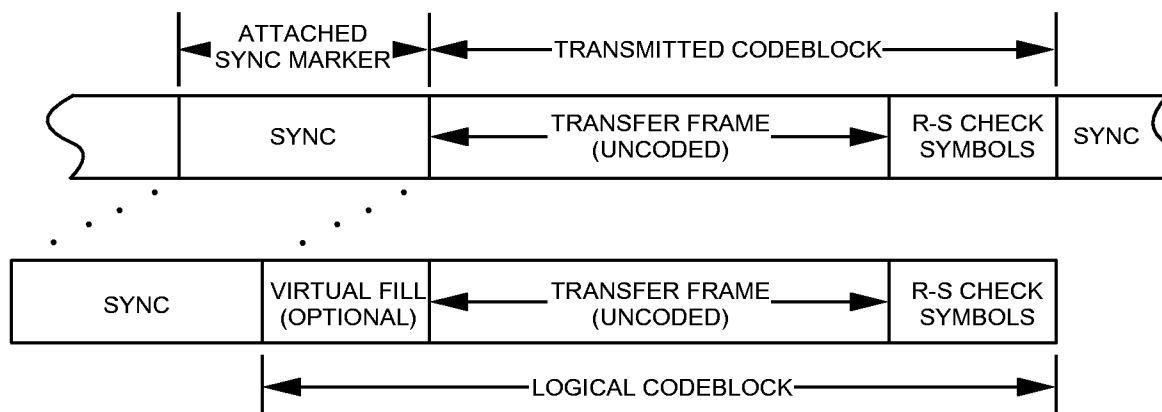

Figure 3-2: Reed-Solomon Codeblock Partitioning

The **Reed-Solomon Check Symbols** consist of the trailing $2EI$ symbols ($2EIJ$ bits) of the codeblock. (As an example, when $E = 16$ and $k = 223$, for $I=5$ this is always 1280 bits.)

The **Telemetry Transfer Frame** is defined by the CCSDS Recommendation for Packet Telemetry (Reference [1]). When used with R-S coding, it has a maximum length of 8920 bits, not including the 32-bit Attached Sync Marker.

The **Attached Sync Marker** used with R-S coding or convolutional coding alone is a 32-bit pattern specified in Section 5 as an aid to synchronization. It precedes the Telemetry Transfer Frame or the Transmitted Codeblock (if R-S coding is used). Frame synchronizers should, therefore, be set to expect a marker at every Telemetry Transfer Frame + 32 bits or at every Transmitted Codeblock + 32 bits (if R-S coding is used).

The **Transmitted Codeblock** consists of the Telemetry Transfer Frame (without the 32-bit sync marker) and R-S check symbols. It is the received data entity physically fed into the R-S decoder. (As an example, when $E = 16$ and $k = 223$, using $I=5$ and no virtual fill, the length of the transmitted codeblock will be 10,200 bits; if virtual fill is used, it will be incrementally shorter, depending on the amount used.)

The **Logical Codeblock** is the logical data entity operated upon by the R-S decoder. It can have a different length than the transmitted codeblock because it accounts for the amount of virtual fill that was introduced. (As an example, when $E = 16$ and $k = 223$, for $I=5$ the logical codeblock always appears to have exactly 10,200 bits in length.)

CCSDS RECOMMENDATION FOR TELEMETRY CHANNEL CODING

Virtual fill is used to logically complete the codeblock and is not transmitted. If used, virtual fill shall:

- (a) consist of all zeros;
 - (b) not be transmitted;
 - (c) not change in length during a tracking pass;
 - (d) be inserted only at the beginning of the codeblock (i.e., after the attached sync marker but before the beginning of the transmitted codeblock);
 - (e) be inserted only in integer multiples of $8I$ bits.
- (11) Dual basis symbol representation and ordering for transmission:

Each 8-bit Reed-Solomon symbol is an element of the finite field $GF(256)$. Since $GF(256)$ is a vector space of dimension 8 over the binary field $GF(2)$, the actual 8-bit representation of a symbol is a function of the particular basis that is chosen. One basis for $GF(256)$ over $GF(2)$ is the set $(1, \alpha^1, \alpha^2, \dots, \alpha^7)$. This means that any element of $GF(256)$ has a representation of the form

$$u_7\alpha^7 + u_6\alpha^6 + \dots + u_1\alpha^1 + u_0\alpha^0$$

where each u_i is either a zero or a one.

Another basis over $GF(2)$ is the set $(1, \beta^1, \beta^2, \dots, \beta^7)$ where $\beta = \alpha^{117}$. To this basis there exists a so-called “dual basis” $(\ell_0, \ell_1, \dots, \ell_7)$. It has the property that

$$\text{Tr}(\ell_i\beta^j) = \begin{cases} 1, & \text{if } i=j \\ 0, & \text{otherwise} \end{cases}$$

for each $j = 0, 1, \dots, 7$. The function $\text{Tr}(z)$, called the “trace”, is defined by

$$\text{Tr}(z) = \sum_{k=0}^7 z^{2^k}$$

for each element z of $GF(256)$. Each Reed-Solomon symbol can also be represented as

$$z_0\ell_0 + z_1\ell_1 + \dots + z_7\ell_7$$

where each z_i is either a zero or a one.

CCSDS RECOMMENDATION FOR TELEMETRY CHANNEL CODING

The representation used in this Recommendation is the dual basis eight-bit string z_0, z_1, \dots, z_7 , transmitted in that order (i.e., with z_0 first). The relationship between the two representations is given by the two equations

$$[z_0, \dots, z_7] = [u_7, \dots, u_0] \begin{bmatrix} 1 & 0 & 0 & 0 & 1 & 1 & 0 & 1 \\ 1 & 1 & 1 & 0 & 1 & 1 & 1 & 1 \\ 1 & 1 & 1 & 0 & 1 & 1 & 0 & 0 \\ 1 & 0 & 0 & 0 & 0 & 1 & 1 & 0 \\ 1 & 1 & 1 & 1 & 1 & 0 & 1 & 0 \\ 1 & 0 & 0 & 1 & 1 & 0 & 0 & 1 \\ 1 & 0 & 1 & 0 & 1 & 1 & 1 & 1 \\ 0 & 1 & 1 & 1 & 1 & 0 & 1 & 1 \end{bmatrix}$$

and

$$[u_7, \dots, u_0] = [z_0, \dots, z_7] \begin{bmatrix} 1 & 1 & 0 & 0 & 0 & 1 & 0 & 1 \\ 0 & 1 & 0 & 0 & 0 & 0 & 1 & 0 \\ 0 & 0 & 1 & 0 & 1 & 1 & 1 & 0 \\ 1 & 1 & 1 & 1 & 1 & 1 & 0 & 1 \\ 1 & 1 & 1 & 1 & 0 & 0 & 0 & 0 \\ 0 & 1 & 1 & 1 & 1 & 0 & 0 & 1 \\ 1 & 0 & 1 & 0 & 1 & 1 & 0 & 0 \\ 1 & 1 & 0 & 0 & 1 & 1 & 0 & 0 \end{bmatrix}$$

Further information relating the dual basis (Berlekamp) and conventional representations is given in Annex B. Also included is a recommended scheme for permitting the symbols generated in a conventional encoder to be transformed to meet the symbol representation required by this document.

(12) Synchronization:

Codeblock synchronization of the Reed-Solomon decoder is achieved by synchronization of the Attached Sync Marker associated with each codeblock. (See Section 5.)

(13) Ambiguity Resolution:

The ambiguity between true and complemented data must be resolved so that only true data is provided to the Reed-Solomon decoder. Data in NRZ-L form is normally resolved using the 32-bit Attached Sync Marker, while NRZ-M data is self-resolving.

(Blank page)

CCSDS RECOMMENDATION FOR TELEMETRY CHANNEL CODING

4 TURBO CODING¹

4.1 INTRODUCTION

Turbo codes are binary block codes with large code blocks (hundreds or thousands of bits). They are systematic and inherently non-transparent.² Phase ambiguities are resolved using frame markers, which are required for Codeblock synchronization.

Turbo codes may be used to obtain even greater coding gain than those provided by concatenated coding systems. Operational environment and performance of the recommended turbo codes are discussed in Reference [D2].

NOTES

- 1 Turbo coding, by itself, cannot guarantee sufficient bit transitions to keep receiver symbol synchronizers in lock. Unless sufficient symbol transition density is ensured by other means (such as data, coding or modulation technique), then the Pseudo-randomizer defined in section 6 is required.
- 2 While providing outstanding coding gain, turbo codes may still leave some residual errors in the decoded output. For this reason, when CCSDS Transfer Frames or Virtual Channel Data Units are used, references [1] and [2], respectively, require that a cyclic redundancy check (CRC) be used to validate the frame.

1 Implementers should be aware that a wide class of turbo codes is covered by a patent by France Télécom and Télédiffusion de France under US Patent 5,446,747 and its counterparts in other countries. Potential user agencies should direct their requests for licenses to:

Mr. Christian HAMON
 CCETT GIE/CVP
 4 rue du Clos Courtel
 BP59
 35512 CESSON SEVIGNE Cedex
 France
 Tel: +33 2 99 12 48 05
 Fax: +33 2 99 12 40 98
 E-mail: christian.hamon@cnet.francetelecom.fr

2 Differential encoding (i.e., NRZ-M signaling) after the turbo encoder is not recommended since soft decoding would require the use of differential detection with considerable loss of performance. Differential encoding before the turbo encoder cannot be used because the turbo codes recommended in this document are non-transparent. This implies that phase ambiguities have to be detected and resolved by the frame synchronizer.

CCSDS RECOMMENDATION FOR TELEMETRY CHANNEL CODING

4.2 SPECIFICATION

A turbo encoder is a combination of two simple encoders. The input is a frame of k information bits. The two component encoders generate parity symbols from two simple recursive convolutional codes, each with a small number of states. The information bits are also sent uncoded. A key feature of turbo codes is an interleaver, which permutes bit-wise the original k information bits before input to the second encoder.

The recommended turbo code is a systematic code with the following specifications:

- (1) Code type: Systematic parallel concatenated turbo code.
- (2) Number of component codes: 2 (plus an uncoded component to make the code systematic).
- (3) Type of component codes: Recursive convolutional codes.
- (4) Number of states of each convolutional component code: 16.
- (5) Nominal¹ Code Rates: $r = 1/2, 1/3, 1/4, \text{ or } 1/6$ (selectable).
- (6) The specified information block lengths k are shown in Table 4-1. They are chosen for compatibility with the corresponding Reed-Solomon interleaving depths, also shown in Table 4-1.

The corresponding codeblock lengths in bits, $n=(k+4)/r$, for the specified code rates are shown in Table 4-2.

Table 4-1: Specified Information Block Lengths

Information block length k , bits	Corresponding Reed-Solomon interleaving depth I	Notes
1784 (=223 × 1 octets)	1	For very low data rates or low latency
3568 (=223 × 2 octets)	2	
7136 (=223 × 4 octets)	4	
8920 (=223 × 5 octets)	5	
16384	Not Applicable	For highest coding gain

¹ Because of “trellis termination” symbols (see item 10 below), the true code rates (defined as the ratios of the information block lengths to the codeblock lengths in Table 4-2 of item 6) are slightly smaller than the nominal code rates. In this recommendation, the terminology “code rate” always refer to the nominal code rates, $r = 1/2, 1/3, 1/4, \text{ or } 1/6$.

CCSDS RECOMMENDATION FOR TELEMETRY CHANNEL CODING

Table 4-2: Codeblock Lengths for Supported Code Rates (Measured in Bits)

Information block length k	Codeblock length n			
	rate 1/2	rate 1/3	rate 1/4	rate 1/6
1784	3576	5364	7152	10728
3568	7144	10716	14288	21432
7136	14280	21420	28560	42840
8920	17848	26772	35696	53544
16384	32776	49164	65552	98328

(7) Turbo Code Permutation:

The interleaver is a fundamental component of the turbo encoding and decoding process. The interleaver for turbo codes is a fixed bit-by-bit permutation of the entire block of data. Unlike the symbol-by-symbol rectangular interleaver used with Reed-Solomon codes, the turbo code permutation scrambles individual bits and resembles a randomly selected permutation in its lack of apparent orderliness.

The recommended permutation for each specified block length k is given by a particular reordering of the integers $1, 2, \dots, k$ as generated by the following algorithm.

First express k as $k=k_1k_2$. The parameters k_1 and k_2 for the specified block sizes are given in Table 4-3.

Next do the following operations for $s=1$ to $s=k$ to obtain permutation numbers $\pi(s)$. In the equation below, $\lfloor x \rfloor$ denotes the largest integer less than or equal to x , and p_q denotes one of the following eight prime integers:

$$p_1 = 31; p_2 = 37; p_3 = 43; p_4 = 47; p_5 = 53; p_6 = 59; p_7 = 61; p_8 = 67$$

CCSDS RECOMMENDATION FOR TELEMETRY CHANNEL CODING

Table 4-3: Parameters k_1 and k_2 for Specified Information Block Lengths

Information block length	k_1	k_2
1784	8	223
3568	8	223×2
7136	8	223×4
8920	8	223×5
16384	(note)	(note)
NOTE – These parameters are currently under study and will be incorporated in a later revision.		

$$\begin{aligned}
 m &= (s - 1) \bmod 2 \\
 i &= \left\lfloor \frac{s - 1}{2 k_2} \right\rfloor \\
 j &= \left\lfloor \frac{s - 1}{2} \right\rfloor - i k_2 \\
 t &= (19i + 1) \bmod \frac{k_1}{2} \\
 q &= t \bmod 8 + 1 \\
 c &= (p_q j + 21m) \bmod k_2 \\
 \pi(s) &= 2(t + c \frac{k_1}{2} + 1) - m
 \end{aligned}$$

The interpretation of the permutation numbers is such that the s th bit read out on line “in b” in Figure 4-2 is the $\pi(s)$ th bit of the input information block, as shown in Figure 4-1.

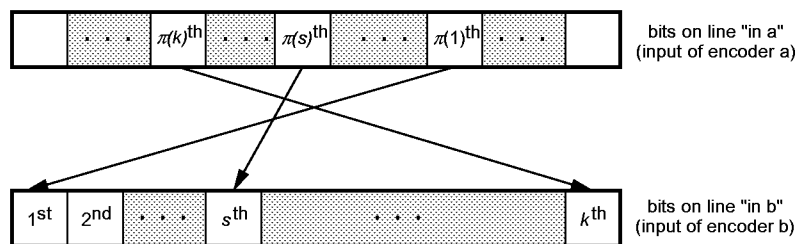

Figure 4-1: Interpretation of Permutation

CCSDS RECOMMENDATION FOR TELEMETRY CHANNEL CODING

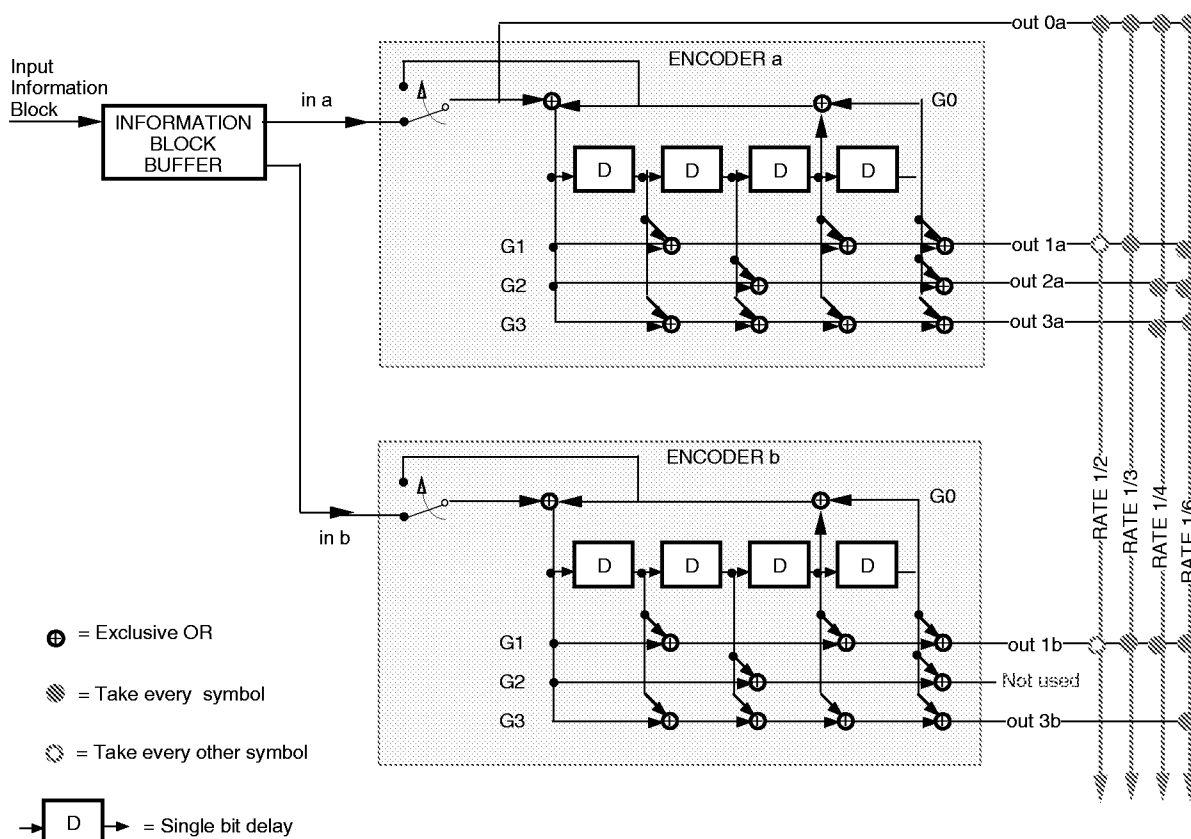

Figure 4-2: Turbo Encoder Block Diagram

(8) Backward and Forward Connection Vectors (see Figure 4-2):

- (a) Backward connection vector for both component codes and all code rates: $G0 = 10011$.
- (b) Forward connection vector for both component codes and rates 1/2 and 1/3: $G1 = 11011$. Puncturing of every other symbol from each component code is necessary for rate 1/2. No puncturing is done for rate 1/3.
- (c) Forward connection vectors for rate 1/4: $G2 = 10101$, $G3 = 11111$ (1st component code); $G1 = 11011$ (2nd component code). No puncturing is done for rate 1/4.
- (d) Forward connection vectors for rate 1/6: $G1 = 11011$, $G2 = 10101$, $G3 = 11111$ (1st component code); $G1 = 11011$, $G3 = 11111$ (2nd component code). No puncturing is done for rate 1/6.

(9) Turbo Encoder Block Diagram:

The recommended encoder block diagram is shown in Figure 4-2. Each input frame of k information bits is held in a frame buffer, and the bits in the buffer are read out in two different orders for the two component encoders. The first

CCSDS RECOMMENDATION FOR TELEMETRY CHANNEL CODING

component encoder (a) operates on the bits in unpermuted order (“in a”), while the second component encoder (b) receives the same bits permuted by the interleaver (“in b”). The read-out addressing for “in a” is a simple counter, while the addressing for “in b” is specified by the turbo code permutation described in item 7 above.

The component encoders are recursive convolutional encoders realized by feedback shift registers as shown in Figure 4-2. The circuits shown in this figure implement the backward connection vector, G_0 , and the forward connection vectors, G_1 , G_2 , G_3 , specified in item 8 above. A key difference between these convolutional component encoders and the standalone convolutional encoder recommended in Section 2-1 is their recursiveness. In the figure this is indicated by the signal (corresponding to the backward connection vector G_0) fed back into the leftmost adder of each component encoder.

(10) Turbo Codeblock Specification:

Both component encoders in Figure 4-2 are initialized with 0s in all registers, and both are run for a total of $k+4$ bit times, producing an output Codeblock of $(k+4)/r$ encoded symbols, where r is the nominal code rate. For the first k bit times, the input switches are in the lower position (as indicated in the figure) to receive input data. For the final 4 bit times, these switches move to the upper position to receive feedback from the shift registers. This feedback cancels the same feedback sent (unswitched) to the leftmost adder and causes all four registers to become filled with zeros after the final 4 bit times. Filling the registers with zeros is called terminating the trellis. During trellis termination the encoder continues to output nonzero encoded symbols. In particular, the “systematic uncoded” output (line “out 0a” in the figure) includes an extra 4 bits from the feedback line in addition to the k information bits.

In Figure 4-2, the encoded symbols are multiplexed from top-to-bottom along the output line for the selected code rate to form the Turbo Codeblock. For the rate $1/3$ code, the output sequence is (out 0a, out 1a, out 1b); for rate $1/4$, the sequence is (out 0a, out 2a, out 3a, out 1b); for rate $1/6$, the sequence is (out 0a, out 1a, out 2a, out 3a, out 1b, out 3b). These sequences are repeated for $(k+4)$ bit times. For the rate $1/2$ code, the output sequence is (out 0a, out 1a, out 0a, out 1b), repeated $(k+4)/2$ times. Note that this pattern implies that out 1b is the first to be punctured, out 1a is the second, and so forth. The Turbo Codeblocks constructed from these output sequences are depicted in Figure 4-3 for the four nominal code rates.

CCSDS RECOMMENDATION FOR TELEMETRY CHANNEL CODING

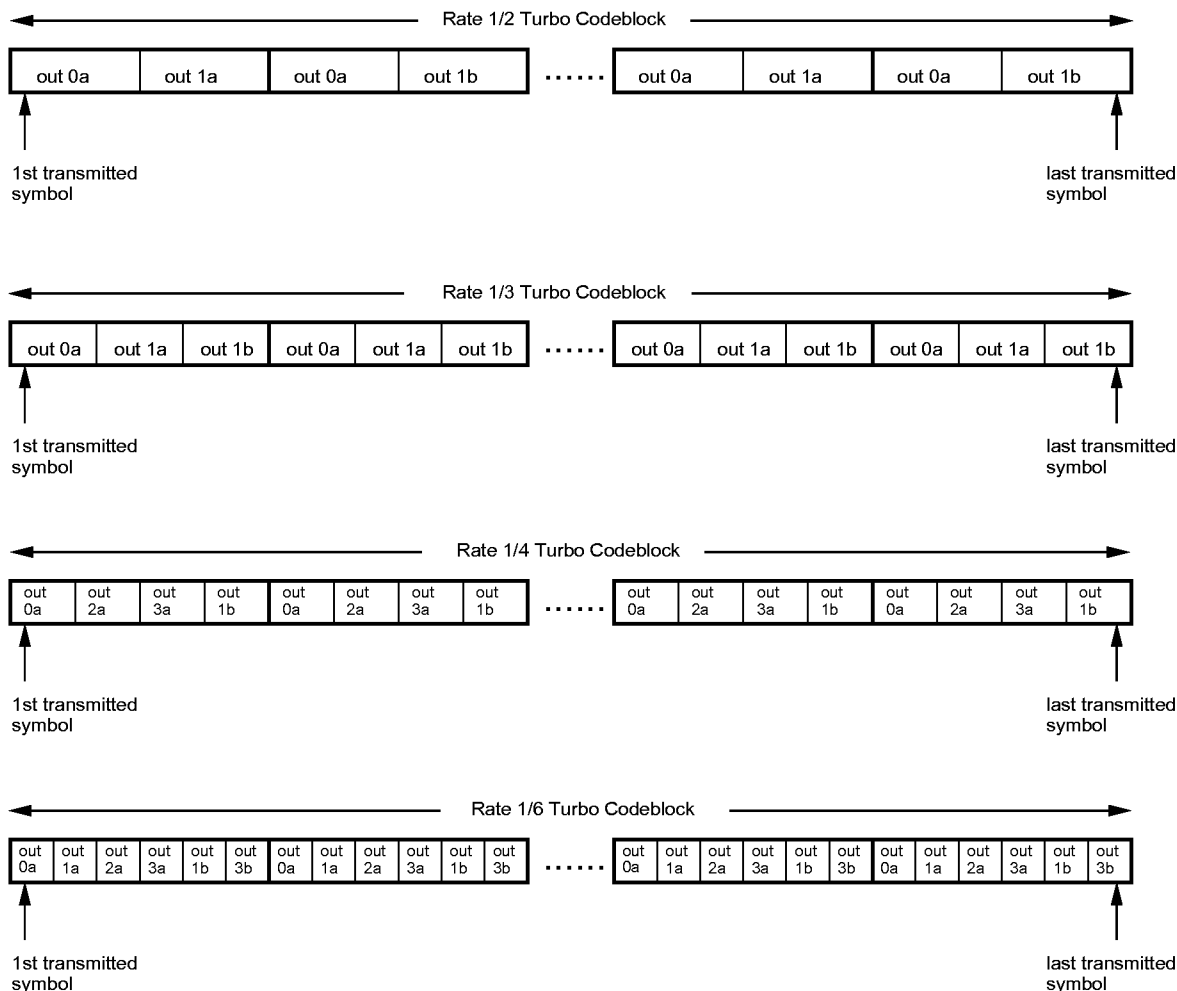

Figure 4-3: Turbo Codeblocks for Different Code Rates

(11) Turbo Codeblock Synchronization:

Codeblock synchronization of the turbo decoder is achieved by synchronization of an Attached Sync Marker associated with each Turbo Codeblock. The Attached Sync Marker (ASM) is a bit pattern specified in Section 5 as an aid to synchronization, and it precedes the Turbo Codeblock. Frame synchronizers should be set to expect a marker at a recurrence interval equal to the length of the ASM plus that of the Turbo Codeblock.

A diagram of a Turbo Codeblock with Attached Sync Marker is shown in Figure 4-4. Note that the length of the Turbo Codeblock is inversely proportional to the nominal code rate r .

CCSDS RECOMMENDATION FOR TELEMETRY CHANNEL CODING

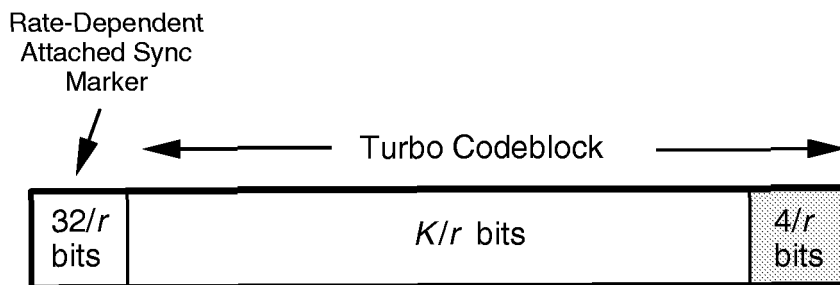

$r = 1/2, 1/3, 1/4, \text{ or } 1/6$ (nominal code rate)

$K =$ Telemetry Transfer Frame Length or Information Block Length

Figure 4-4: Turbo Codeblock with Attached Sync Marker

CCSDS RECOMMENDATION FOR TELEMETRY CHANNEL CODING

5 FRAME SYNCHRONIZATION

5.1 INTRODUCTION

Frame or Codeblock synchronization is necessary for proper decoding of Reed-Solomon Codeblocks and Turbo Codeblocks, and subsequent processing of the Transfer Frames. Furthermore, it is necessary for synchronization of the pseudo-random generator, if used (see Section 6). It is also useful in assisting the node synchronization process of the Viterbi decoder for the convolutional code.

5.2 THE ATTACHED SYNC MARKER (ASM)

Synchronization of the Reed-Solomon or Turbo Codeblock (or Transfer Frame, if the telemetry channel is not Reed-Solomon coded or turbo coded) is achieved by using a stream of fixed-length Codeblocks (or Transfer Frames) with an Attached Sync Marker (ASM) between them. Synchronization is acquired on the receiving end by recognizing the specific bit pattern of the ASM in the telemetry channel data stream; synchronization is then customarily confirmed by making further checks.

5.2.1 ENCODER SIDE

If the telemetry channel is uncoded, Reed-Solomon coded, or turbo coded, the code symbols comprising the ASM are attached directly to the encoder output without being encoded by the Reed-Solomon or turbo code. If an inner convolutional code is used in conjunction with an outer Reed-Solomon code, the ASM is encoded by the inner code but not by the outer code.

5.2.2 DECODER SIDE

For a concatenated Reed-Solomon and convolutional coding system, the ASM may be acquired either in the channel symbol domain (i.e., before any decoding) or in the domain of bits decoded by the inner code (i.e., the code symbol domain of the Reed-Solomon code). For a turbo coding system, the ASM must be acquired in the channel symbol domain (i.e., the code symbol domain of the turbo code).

5.3 ASM BIT PATTERNS

The ASM for telemetry data that is not turbo coded shall consist of a 32-bit (4-octet) marker with a pattern shown in Figure 5-1. The ASM for data that is turbo coded with nominal code rate $r = 1/2, 1/3, 1/4, \text{ or } 1/6$ shall consist of a $32/r$ -bit ($4/r$ -octet) marker with bit patterns shown in Figure 5-2. The ASM bit patterns are represented in hexadecimal notation as:

ASM for non-turbo-coded data:	1ACFFC1D
ASM for rate-1/2 turbo coded data:	034776C7272895B0
ASM for rate-1/3 turbo coded data:	25D5C0CE8990F6C9461BF79C
ASM for rate-1/4 turbo coded data:	034776C7272895B0 FCB88938D8D76A4F
ASM for rate-1/6 turbo coded data:	25D5C0CE8990F6C9461BF79C DA2A3F31766F0936B9E40863

CCSDS RECOMMENDATION FOR TELEMETRY CHANNEL CODING

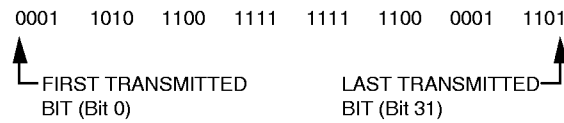
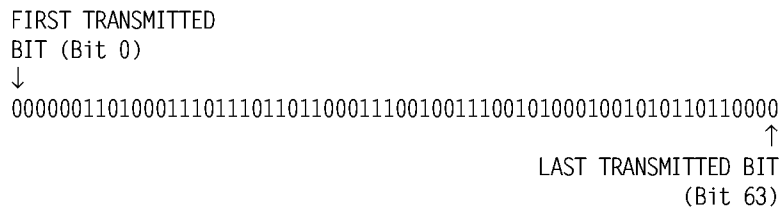
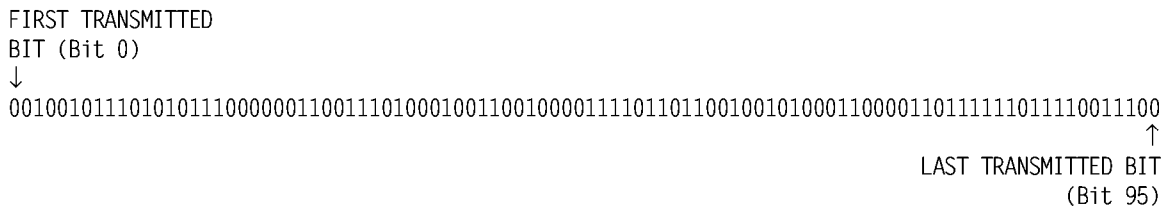

Figure 5-1: ASM Bit Pattern for Non-Turbo-Coded Data

For rate 1/2 turbo code



For rate 1/3 turbo code



For rate 1/4 turbo code

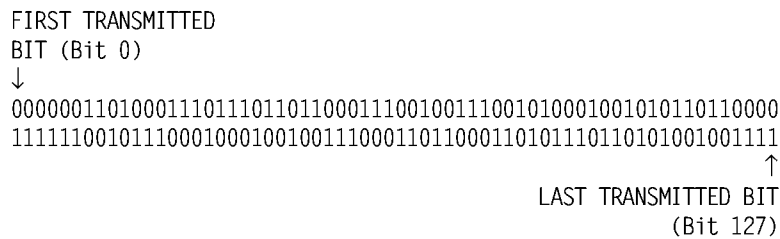

For rate 1/6 turbo code

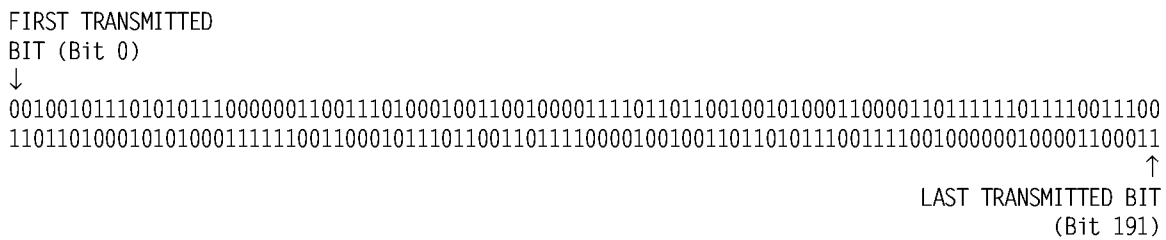

Figure 5-2: ASM Bit Pattern for Turbo-Coded Data

CCSDS RECOMMENDATION FOR TELEMETRY CHANNEL CODING

5.4 LOCATION OF ASM

The ASM is attached to (i.e., shall immediately precede) the Reed-Solomon or Turbo Codeblock, or the Transfer Frame if the telemetry channel is not Reed-Solomon or turbo coded.

The ASM for one Codeblock (or Transfer Frame) shall immediately follow the end of the preceding Codeblock (or Transfer Frame); i.e., there shall be no intervening bits (data or fill) preceding the ASM.

5.5 RELATIONSHIP OF ASM TO REED-SOLOMON AND TURBO CODEBLOCKS

The ASM is NOT a part of the encoded data space of the Reed-Solomon Codeblock, and it is not presented to the input of the Reed-Solomon encoder or decoder. This prevents the encoder from routinely regenerating a second, identical marker in the check symbol field under certain repeating data-dependent conditions (e.g., a test pattern of 0101010101 ... among others) which could cause synchronization difficulties at the receiving end. The relationship among the ASM, Reed-Solomon Codeblock, and Transfer Frame is illustrated in Figure 3-2.

Similarly, the ASM is not presented to the input of the turbo encoder or decoder. It is directly attached to the Turbo Codeblock, as shown in Figure 4-4.

5.6 ASM FOR EMBEDDED DATA STREAM

A different ASM pattern (see Figure 5-3) may be required where another data stream (e.g., a stream of transfer frames played back from a tape recorder in the forward direction) is inserted into the data field of the Transfer Frame of the main stream appearing on the telemetry channel. The ASM for the embedded data stream, to differentiate it from the main stream marker, shall consist of a 32-bit (4-octet) marker with a pattern as follows:

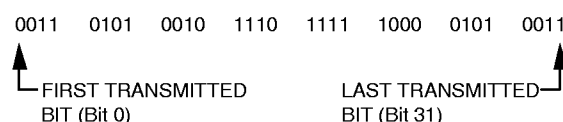

Figure 5-3: Embedded ASM Bit Pattern

This pattern is represented in hexadecimal notation as:

352EF853

(Blank page)

.....

CCSDS RECOMMENDATION FOR TELEMETRY CHANNEL CODING

6 PSEUDO-RANDOMIZER

6.1 INTRODUCTION

In order to maintain bit (or symbol) synchronization with the received telemetry signal, every ground data capture system requires that the incoming signal have a minimum bit transition density (see reference [3]).

If a sufficient bit transition density is not ensured for the channel by other methods (e.g., by use of certain modulation techniques or one of the recommended convolutional codes) then the Pseudo-Randomizer defined in this section is required. Its use is optional otherwise.

The presence or absence of Pseudo-Randomization is fixed for a physical channel and is *managed* (i.e., its presence or absence is not signaled in the telemetry but must be known a priori) by the ground system.

6.2 PSEUDO-RANDOMIZER DESCRIPTION

The method for ensuring sufficient transitions is to exclusive-OR each bit of the Codeblock or Transfer Frame with a standard pseudo-random sequence.

If the Pseudo-Randomizer is used, on the sending end it is applied to the Codeblock or Transfer Frame after turbo encoding or RS encoding (if either is used), but before convolutional encoding (if used). On the receiving end, it is applied to derandomize the data after convolutional decoding (if used) and codeblock synchronization but before Reed-Solomon decoding or turbo decoding (if either is used).¹

The configuration at the sending end is shown in Figure 6-1.

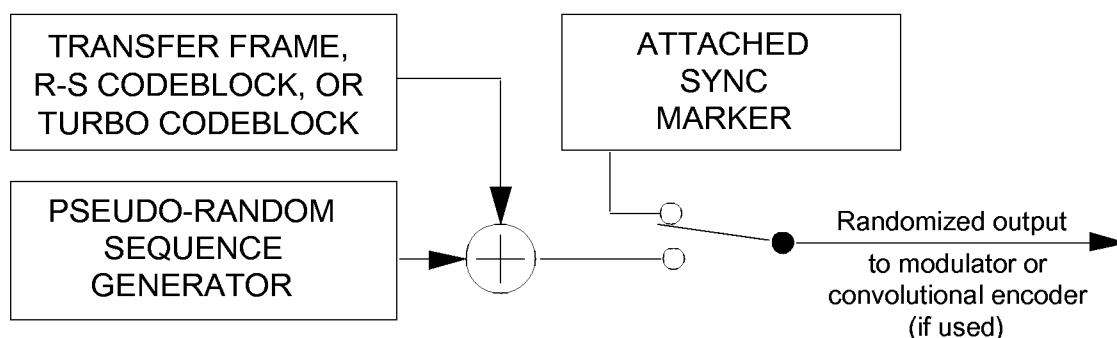

Figure 6-1: Pseudo-Randomizer Configuration

¹ "Derandomization" consists of either: a) exclusive OR-ing the pseudo-random sequence with the received bits of a transfer frame or a Reed-Solomon codeblock, or b) inverting (or not inverting), according to the pseudo-randomizer bit pattern, the demodulator output of a turbo codeblock.

6.3 SYNCHRONIZATION AND APPLICATION OF PSEUDO-RANDOMIZER

The Attached Sync Marker (ASM) is already optimally configured for synchronization purposes and it is therefore used for synchronizing the Pseudo-Randomizer.

The pseudo-random sequence is applied starting with the first bit of the Codeblock or Transfer Frame. On the sending end, the Codeblock or Transfer Frame is randomized by exclusive-ORing the first bit of the Codeblock or Transfer Frame with the first bit of the pseudo-random sequence, followed by the second bit of the Codeblock or Transfer Frame with the second bit of the pseudo-random sequence, and so on.

On the receiving end, the original Codeblock or Transfer Frame is reconstructed using the same pseudo-random sequence. After locating the ASM in the received data stream, the pseudo-random sequence is exclusive-ORed with the data bits immediately following the ASM. The pseudo-random sequence is applied by exclusive-ORing the first bit following the ASM with the first bit of the pseudo-random sequence, followed by the second bit of the data stream with the second bit of the pseudo-random sequence, and so on.

The pseudo-random sequence shall NOT be exclusive-ORed with the ASM.

6.4 SEQUENCE SPECIFICATION

The pseudo-random sequence shall be generated using the following polynomial:

$$h(x) = x^8 + x^7 + x^5 + x^3 + 1$$

This sequence begins at the first bit of the Codeblock or Transfer Frame and repeats after 255 bits, continuing repeatedly until the end of the Codeblock or Transfer Frame. The sequence generator is initialized to the all-ones state at the start of each Codeblock or Transfer Frame.

The first 40 bits of the pseudo-random sequence from the generator are shown below; the leftmost bit is the first bit of the sequence to be exclusive-ORed with the first bit of the Codeblock or Transfer Frame; the second bit of the sequence is exclusive-ORed with the second bit of the Codeblock or Transfer Frame, and so on.

1111 1111 0100 1000 0000 1110 1100 0000 1001 1010

6.5 LOGIC DIAGRAM

Figure 6-2 represents a possible generator for the specified sequence.

CCSDS RECOMMENDATION FOR TELEMETRY CHANNEL CODING

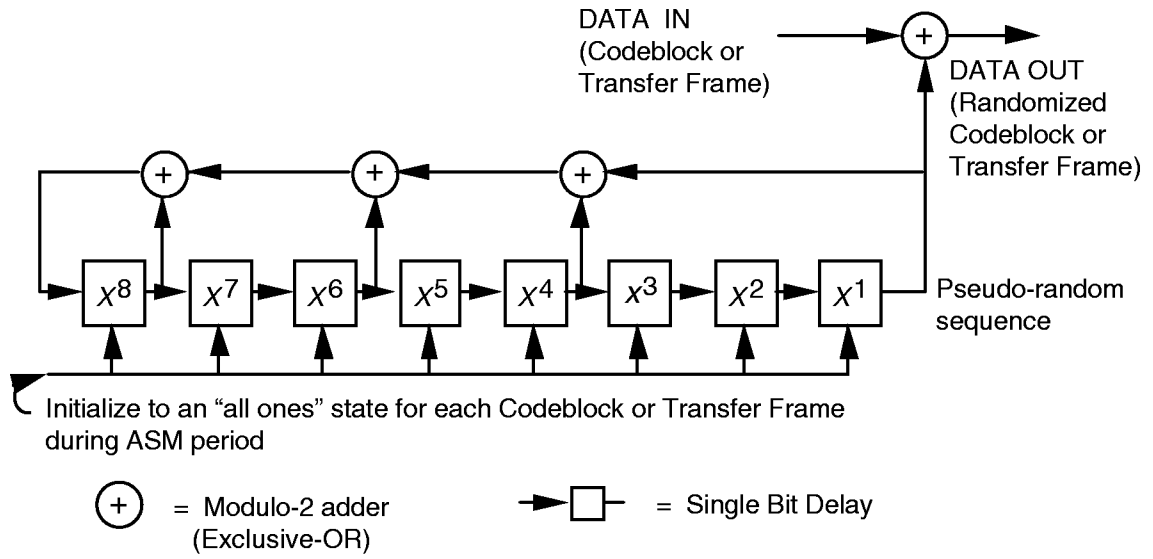

Figure 6-2: Pseudo-Randomizer Logic Diagram

(Blank page)

11754:2003(E)

CCSDS RECOMMENDATION FOR TELEMETRY CHANNEL CODING

ANNEX A

TRANSFORMATION BETWEEN BERLEKAMP AND CONVENTIONAL REPRESENTATIONS

(This annex is **not** part of the Recommendation)

A 1 PURPOSE

This Annex provides information to assist users of the Reed-Solomon code in this Recommendation to transform between the Berlekamp (dual basis) and Conventional representations. In addition, it shows where transformations are made to allow a conventional encoder to produce the dual basis representation on which the Recommendation is based.

A 2 TRANSFORMATION

Referring to Figure A-1, it can be seen that information symbols I entering and check symbols C emanating from the Berlekamp R-S encoder are interpreted as

$$[z_0, z_1, \dots, z_7]$$

where the components z_i are coefficients of ℓ_i , respectively:

$$z_0\ell_0 + z_1\ell_1 + \dots + z_7\ell_7$$

Information symbols I' entering and check symbols C' emanating from the conventional R-S encoder are interpreted as

$$[u_7, u_6, \dots, u_0]$$

where the components u_j are coefficients of α^j , respectively:

$$u_7\alpha^7 + u_6\alpha^6 + \dots + u_0$$

A pre- and post-transformation is required when employing a conventional R-S encoder.

CCSDS RECOMMENDATION FOR TELEMETRY CHANNEL CODING

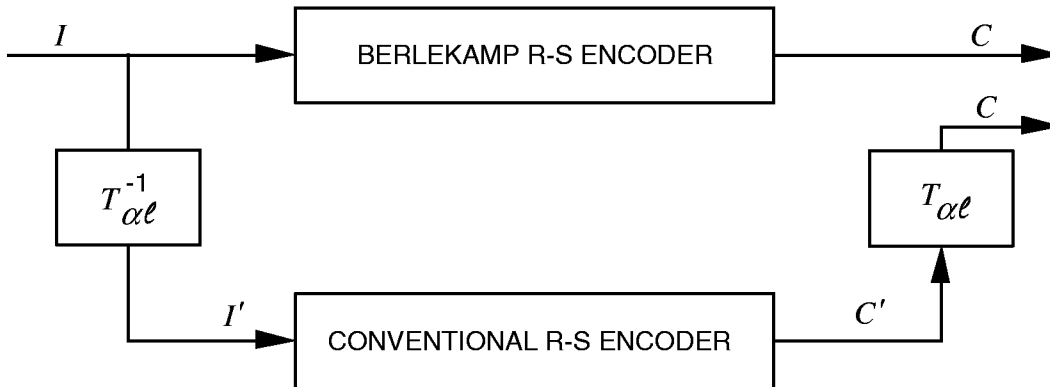

Figure A-1: Transformational Equivalence

Conventional and Berlekamp types of $(255,k)$ Reed-Solomon encoders are assumed to have the same self-reciprocal generator polynomial whose coefficients appear in paragraph 4.2 (4) and (5). The representation of symbols associated with the conventional encoder is the polynomials in “ α^i ” appearing in Table A-1, below. Corresponding to each polynomial in “ α^i ” is the representation in the dual basis of symbols associated with the Berlekamp type encoder.

Given

$$\alpha^i = u_7 \alpha^7 + u_6 \alpha^6 + \dots + u_0$$

where $0 \leq i < 255$ (and α^* denotes the zero polynomial, $u_7, u_6, \dots = 0, 0, \dots$),

the corresponding element is

$$z = z_0 l_0 + z_1 l_1 + \dots + z_7 l_7$$

where

$$[z_0, z_1, \dots, z_7] = [u_7, u_6, \dots, u_0] T_{\alpha l}$$

and

$$T_{\alpha l} = \begin{bmatrix} 1 & 0 & 0 & 0 & 1 & 1 & 0 & 1 \\ 1 & 1 & 1 & 0 & 1 & 1 & 1 & 1 \\ 1 & 1 & 1 & 0 & 1 & 1 & 0 & 0 \\ 1 & 0 & 0 & 0 & 0 & 1 & 1 & 0 \\ 1 & 1 & 1 & 1 & 1 & 0 & 1 & 0 \\ 1 & 0 & 0 & 1 & 1 & 0 & 0 & 1 \\ 1 & 0 & 1 & 0 & 1 & 1 & 1 & 1 \\ 0 & 1 & 1 & 1 & 1 & 0 & 1 & 1 \end{bmatrix}$$

Row 1, row 2, ..., and row 8 in $T_{\alpha l}$ are representations in the dual basis of α^7 (10 ... 0), α^6 (010 ... 0), ..., and α^0 (00 ... 01), respectively.

CCSDS RECOMMENDATION FOR TELEMETRY CHANNEL CODING

The inverse of $T_{\alpha\ell}$ is

$$T_{\alpha\ell}^{-1} = \begin{bmatrix} 1 & 1 & 0 & 0 & 0 & 1 & 0 & 1 \\ 0 & 1 & 0 & 0 & 0 & 0 & 1 & 0 \\ 0 & 0 & 1 & 0 & 1 & 1 & 1 & 0 \\ 1 & 1 & 1 & 1 & 1 & 1 & 0 & 1 \\ 1 & 1 & 1 & 1 & 0 & 0 & 0 & 0 \\ 0 & 1 & 1 & 1 & 1 & 0 & 0 & 1 \\ 1 & 0 & 1 & 0 & 1 & 1 & 0 & 0 \\ 1 & 1 & 0 & 0 & 1 & 1 & 0 & 0 \end{bmatrix}$$

Row 1, row 2, ..., and row 8 in $T_{\alpha\ell}^{-1}$ are polynomials in " α " corresponding to ℓ_0 (10 ... 0), ℓ_1 (010 ... 0), ..., and ℓ_7 (00, ... 01), respectively. Thus,

$$[z_0, z_1, \dots, z_7] T_{\alpha\ell}^{-1} = [u_7, u_6, \dots, u_0]$$

Example 1:

Given information symbol I ,

$$[z_0, z_1, \dots, z_7] = 10111001$$

then

$$[10111001] T_{\alpha\ell}^{-1} = [u_7, u_6, \dots, u_0] = 00101010 = I'$$

Note that the arithmetic operations are reduced modulo 2. Also,

$$[z_0, z_1, \dots, z_7] = 10111001$$

and

$$[u_7, u_6, \dots, u_0] = 00101010 (\alpha^{213})$$

are corresponding entries in Table A-1.

CCSDS RECOMMENDATION FOR TELEMETRY CHANNEL CODING

Example 2:

Given check symbol C' ,

$$[\alpha_7, \alpha_6, \dots, \alpha_0] = 01011001 \ (\alpha^{152})$$

Then,

$$[0\ 1\ 0\ 1\ 1\ 0\ 0\ 1] \begin{bmatrix} 1 & 0 & 0 & 0 & 1 & 1 & 0 & 1 \\ 1 & 1 & 1 & 0 & 1 & 1 & 1 & 1 \\ 1 & 1 & 1 & 0 & 1 & 1 & 0 & 0 \\ 1 & 0 & 0 & 0 & 0 & 1 & 1 & 0 \\ 1 & 1 & 1 & 1 & 1 & 0 & 1 & 0 \\ 1 & 0 & 0 & 1 & 1 & 0 & 0 & 1 \\ 1 & 0 & 1 & 0 & 1 & 1 & 1 & 1 \\ 0 & 1 & 1 & 1 & 1 & 0 & 1 & 1 \end{bmatrix} = [z_0, z_1, \dots, z_7] = 11101000 = C$$

CCSDS RECOMMENDATION FOR TELEMETRY CHANNEL CODING

Table A-1: Equivalence of Representations¹

P O W E R	POLY IN ALPHA	$\alpha_{01234567}$	P O W E R	POLY IN ALPHA	$\alpha_{01234567}$
=====					
*	00000000	00000000	31	11001101	01111010
0	00000001	01111011	32	00011101	10011110
1	00000010	10101111	33	00111010	00111111
2	00000100	10011001	34	01110100	00011100
3	00001000	11111010	35	11101000	01110100
4	00010000	10000110	36	01010111	00100100
5	00100000	11101100	37	10101110	10101101
6	01000000	11101111	38	11011011	11001010
7	10000000	10001101	39	00110001	00010001
8	10000111	11000000	40	01100010	10101100
9	10001001	00001100	41	11000100	11111011
10	10010101	11101001	42	00001111	10110111
11	10101101	01111001	43	00011110	01001010
12	11011101	11111100	44	00111100	00001001
13	00111101	01110010	45	01111000	01111111
14	01111010	11010000	46	11110000	<u>00001000</u>
15	11110100	10010001	47	01100111	01001110
16	01101111	10110100	48	11001110	10101110
17	11011110	00101000	49	00011011	10101000
18	00111011	01000100	50	00110110	01011100
19	01110110	10110011	51	01101100	01100000
20	11101100	11101101	52	11011000	00011110
21	01011111	11011110	53	00110111	00100111
22	10111110	00101011	54	01101110	11001111
23	11111011	00100110	55	11011100	10000111
24	01110001	11111110	56	00111111	11011101
25	11100010	00100001	57	01111110	01001001
26	01000011	00111011	58	11111100	01101011
27	10000110	10111011	59	01111111	00110010
28	10001011	10100011	60	11111110	11000100
29	10010001	01110000	61	01111011	10101011
30	10100101	10000011	62	11110110	00111110

¹ From Table 4 of Reference [D3]. Note: Coefficients of the “Polynomial in Alpha” column are listed in descending powers of α , starting with α^7 .

CCSDS RECOMMENDATION FOR TELEMETRY CHANNEL CODING

Table A-1: Cont'd

P			P		
O	POLY		O	POLY	
W	IN	01234567	W	IN	01234567
E	ALPHA		E	ALPHA	
R			R		

63	01101011	00101101	95	10111010	10110010
64	11010110	11010010	96	11110011	11011100
65	00101011	11000010	97	01100001	01111000
66	01010110	01011111	98	11000010	11001101
67	10101100	<u>00000010</u>	99	00000011	11010100
68	11011111	01010011	100	00000110	00110110
69	00111001	11101011	101	00001100	01100011
70	01110010	00101010	102	00011000	01111100
71	11100100	00010111	103	00110000	01101010
72	01001111	01011000	104	01100000	00000011
73	10011110	11000111	105	11000000	01100010
74	10111011	11001001	106	00000111	01001101
75	11110001	01110011	107	00001110	11001100
76	01100101	11100001	108	00011100	11100101
77	11001010	00110111	109	00111000	10010000
78	00010011	01010010	110	01110000	10000101
79	00100110	11011010	111	11100000	10001110
80	01001100	10001100	112	01000111	10100010
81	10011000	11110001	113	10001110	01000001
82	10110111	10101010	114	10011011	00100101
83	11101001	00001111	115	10110001	10011100
84	01010101	10001011	116	11100101	01101100
85	10101010	00110100	117	01001101	11110111
86	11010011	00110000	118	10011010	01011110
87	00100001	10010111	119	10110011	00110011
88	01000010	<u>01000000</u>	120	11100001	11110101
89	10000100	00010100	121	01000101	00001101
90	10001111	00111010	122	10001010	11011000
91	10011001	10001010	123	10010011	11011111
92	10110101	00000101	124	10100001	00011010
93	11101101	10010110	<u>125</u>	11000101	<u>10000000</u>
94	01011101	01110001	126	00001101	00011000

CCSDS RECOMMENDATION FOR TELEMETRY CHANNEL CODING

Table A-1: Cont'd

P			P		
O	POLY		O	POLY	
W	IN	<i>l</i> 01234567	W	IN	<i>l</i> 01234567
E	ALPHA		E	ALPHA	
R			R		

=====					
127	00011010	11010011	159	10000101	01101111
128	00110100	11110011	160	10001101	10010101
129	01101000	11111001	161	10011101	00010011
130	11010000	11100100	162	10111101	11111111
131	00100111	10100001	<u>163</u>	11111101	<u>00010000</u>
132	01001110	00100011	164	01111101	10011101
133	10011100	01101000	165	11111010	01011101
134	10111111	01010000	166	01110011	01010001
135	11111001	10001001	167	11100110	10111000
136	01110101	01100111	168	01001011	11000001
137	11101010	11011011	169	10010110	00111101
138	01010011	10111101	170	10101011	01001111
139	10100110	01010111	171	11010001	10011111
140	11001011	01001100	172	00100101	00001110
141	00010001	11111101	173	01001010	10111010
142	00100010	01000011	174	10010100	10010010
143	01000100	01110110	175	10101111	11010110
144	10001000	01110111	176	11011001	01100101
145	10010111	01000110	177	00110101	10001000
146	10101001	11100000	178	01101010	01010110
147	11010101	00000110	179	11010100	01111101
148	00101101	11110100	180	00101111	01011011
149	01011010	00111100	181	01011110	10100101
150	10110100	01111110	182	10111100	10000100
151	11101111	00111001	183	11111111	10111111
152	01011001	11101000	<u>184</u>	01111001	<u>00000100</u>
153	10110010	01001000	185	11110010	10100111
154	11100011	01011010	186	01100011	11010111
155	01000001	10010100	187	11000110	01010100
156	10000010	00100010	188	00001011	00101110
157	10000011	01011001	189	00010110	10110000
158	10000001	11110110	190	00101100	10001111

CCSDS RECOMMENDATION FOR TELEMETRY CHANNEL CODING

Table A-1: Concluded

P	O	POLY	W	IN	01234567	P	O	POLY	W	IN	01234567
E	R	ALPHA				E	R	ALPHA			
191	01011000		10010011			223	01100100		10011010		
192	10110000		11100111			224	11001000		10011000		
193	11100111		11000011			225	00010111		11001011		
194	01001001		01101110			226	00101110		<u>00100000</u>		
195	10010010		10100100			227	01011100		00001010		
196	10100011		10110101			228	10111000		00011101		
197	11000001		00011001			229	11110111		01000101		
198	00000101		11100010			230	01101001		10000010		
199	00001010		01010101			231	11010010		01001011		
200	00010100		00011111			232	00100011		00111000		
201	00101000		00010110			233	01000110		11011001		
202	01010000		01101001			234	10001100		11101110		
203	10100000		01100001			235	10011111		10111100		
204	11000111		00101111			236	10111001		01100110		
205	00001001		10000001			237	11110101		11101010		
206	00010010		00101001			238	01101101		00011011		
207	00100100		01110101			239	11011010		10110001		
208	01001000		00010101			240	00110011		10111110		
209	10010000		00001011			241	01100110		00110101		
210	10100111		00101100			242	11001100		<u>00000001</u>		
211	11001001		11100011			243	00011111		00110001		
212	00010101		01100100			244	00111110		10100110		
213	00101010		10111001			245	01111100		11100110		
214	01010100		11110000			246	11111000		11110010		
215	10101000		10011011			247	01110111		11001000		
216	11010111		10101001			248	11101110		01000010		
217	00101001		01101101			249	01011011		01000111		
218	01010010		11000110			250	10110110		11010001		
219	10100100		11111000			251	11101011		10100000		
220	11001111		11010101			252	01010001		00010010		
221	00011001		00000111			253	10100010		11001110		
222	00110010		11000101			254	11000011		10110110		

CCSDS RECOMMENDATION FOR TELEMETRY CHANNEL CODING

ANNEX B

EXPANSION OF REED-SOLOMON COEFFICIENTS

(This annex is not part of the Recommendation.)

Purpose:

While the equations given in the Reed-Solomon Coding Section of this recommendation are fully specifying, this Annex provides additional assistance for those implementing either the $E = 16$ or the $E = 8$ code.

For $E = 16$:

COEFFICIENTS OF $g(x)$			POLYNOMIAL IN α							
			α^7	α^6	α^5	α^4	α^3	α^2	α^1	α^0
G_0	=	$G_{32} = \alpha^0$	0	0	0	0	0	0	0	1
G_1	=	$G_{31} = \alpha^{249}$	0	1	0	1	1	0	1	1
G_2	=	$G_{30} = \alpha^{59}$	0	1	1	1	1	1	1	1
G_3	=	$G_{29} = \alpha^{66}$	0	1	0	1	0	1	1	0
G_4	=	$G_{28} = \alpha^4$	0	0	0	1	0	0	0	0
G_5	=	$G_{27} = \alpha^{43}$	0	0	0	1	1	1	1	0
G_6	=	$G_{26} = \alpha^{126}$	0	0	0	0	1	1	0	1
G_7	=	$G_{25} = \alpha^{251}$	1	1	1	0	1	0	1	1
G_8	=	$G_{24} = \alpha^{97}$	0	1	1	0	0	0	0	1
G_9	=	$G_{23} = \alpha^{30}$	1	0	1	0	0	1	0	1
G_{10}	=	$G_{22} = \alpha^3$	0	0	0	0	1	0	0	0
G_{11}	=	$G_{21} = \alpha^{213}$	0	0	1	0	1	0	1	0
G_{12}	=	$G_{20} = \alpha^{50}$	0	0	1	1	0	1	1	0
G_{13}	=	$G_{19} = \alpha^{66}$	0	1	0	1	0	1	1	0
G_{14}	=	$G_{18} = \alpha^{170}$	1	0	1	0	1	0	1	1
G_{15}	=	$G_{17} = \alpha^5$	0	0	1	0	0	0	0	0
		$G_{16} = \alpha^{24}$	0	1	1	1	0	0	0	1

Note that $G_3 = G_{29} = G_{13} = G_{19}$

Further information, including encoder block diagrams, is provided by Perlman and Lee in Reference [D3].

CCSDS RECOMMENDATION FOR TELEMETRY CHANNEL CODING

For $E = 8$:

COEFFICIENTS OF $g(x)$			POLYNOMIAL IN α							
			α^7	α^6	α^5	α^4	α^3	α^2	α^1	α^0
G_0	=	$G_{16} = \alpha^0$	0	0	0	0	0	0	0	1
G_1	=	$G_{15} = \alpha^{30}$	1	0	1	0	0	1	0	1
G_2	=	$G_{14} = \alpha^{230}$	0	1	1	0	1	0	0	1
G_3	=	$G_{13} = \alpha^{49}$	0	0	0	1	1	0	1	1
G_4	=	$G_{12} = \alpha^{235}$	1	0	0	1	1	1	1	1
G_5	=	$G_{11} = \alpha^{129}$	0	1	1	0	1	0	0	0
G_6	=	$G_{10} = \alpha^{81}$	1	0	0	1	1	0	0	0
G_7	=	$G_9 = \alpha^{76}$	0	1	1	0	0	1	0	1
		$G_8 = \alpha^{173}$	0	1	0	0	1	0	1	0

CCSDS RECOMMENDATION FOR TELEMETRY CHANNEL CODING

ANNEX C

GLOSSARY OF ACRONYMS AND TERMS

(This annex is **not** part of the Recommendation.)

C 1 PURPOSE

This annex defines key acronyms and terms that are used throughout this Recommendation to describe telemetry channel coding.

C 2 TERMS

BLOCK ENCODING: A one-to-one transformation of sequences of length k of elements of a source alphabet to sequences of length n of elements of a code alphabet, $n > k$.

CHANNEL SYMBOL: The unit of output of the innermost encoder.

CODEBLOCK: A codeblock of an (n,k) block code is a sequence of n channel symbols which were produced as a unit by encoding a sequence of k information symbols, and will be decoded as a unit.

CODE RATE: The average ratio of the number of binary digits at the input of an encoder to the number of binary digits at its output.

CODEWORD: In a block code, one of the sequences in the range of the one-to-one transformation (see **BLOCK ENCODING**).

CONCATENATION: The use of two or more codes to process data sequentially with the output of one encoder used as the input of the next.

CONNECTION VECTOR (FORWARD): In convolutional and turbo coding, a vector used to specify one of the parity checks to be computed by the shift register(s) in the encoder. For a shift register with s stages, a connection vector is an s -bit binary number. A bit equal to "one" in position i (counted from the left) indicates that the output of the i th stage of the shift register is to be used in computing that parity check.

CONNECTION VECTOR (BACKWARD): In turbo coding, a vector used to specify the feedback to the shift registers in the encoder. For a shift register with s stages, a backward connection vector is an s -bit binary number. A bit equal to "one" in position i (counted from the left) indicates that the output of the i th stage of the shift register is to be used in computing the feedback value, except for the leftmost bit which is ignored.

CCSDS RECOMMENDATION FOR TELEMETRY CHANNEL CODING

CONSTRAINT LENGTH: In convolutional coding, the number of consecutive input bits that are needed to determine the value of the output symbols at any time.

CONVOLUTIONAL CODE: As used in this document, a code in which a number of output symbols are produced for each I input information bit. Each output symbol is a linear combination of the current input bit as well as some or all of the previous $k-1$ bits where k is the constraint length of the code.

GF(n): The Galois Field consisting of exactly " n " elements.

INNER CODE: In a concatenated coding system, the last encoding algorithm that is applied to the data stream. The data stream here consists of the codewords generated by the outer decoder.

MODULATING WAVEFORM: A way of representing data bits ("1" and "0") by a particular waveform.

NRZ-L: A modulating waveform in which a data "one" is represented by one of two levels, and a data "zero" is represented by the other level.

NRZ-M: A modulating waveform in which a data "one" is represented by a change in level and a data "zero" is represented by no change in level.

OUTER CODE: In a concatenated coding system, the first encoding algorithm that is applied to the data stream.

PUNCTURED CODE: As used in this document, a code obtained by deleting some of the parity symbols generated by the convolutional encoder before transmission. The bandwidth efficiency obtained by puncturing is increased compared to the original code, although the minimum weight (and therefore its error-correcting performance) will be less than that of the original code.

REED-SOLOMON (R-S) SYMBOL: A set of J bits that represents an element in $GF(2^J)$, the code alphabet of a J -bit Reed-Solomon code.

SYSTEMATIC CODE: A code in which the input information sequence appears in unaltered form as part of the output codeword.

TRANSPARENT CODE: A code that has the property that complementing the input of the encoder or decoder results in complementing the output.

TRELLIS TERMINATION: The operation of filling with zeros the s stages of each shift register used in the turbo encoder, after the end of the information block. During trellis termination the encoders continue to output encoded symbols for $s-1$ additional clock cycles.

TURBO CODE: As used in this document, a block code formed by combining two component recursive convolutional codes. A turbo code takes as input a block of k information bits. The input block is sent unchanged to the first component code and bit-wise interleaved (see

CCSDS RECOMMENDATION FOR TELEMETRY CHANNEL CODING

TURBO CODE PERMUTATION) to the second component code. The output is formed by the parity symbols contributed by each component code plus a replica of the information bits.

TURBO CODE PERMUTATION: A fixed bit-by-bit permutation of the entire input block of information bits performed by an interleaver, used in turbo codes.

VIRTUAL FILL: In a systematic block code, a codeword can be divided into an information part and a parity (check) part. Suppose that the information part is N symbols long (a symbol is defined here to be an element of the code's alphabet) and that the parity part is M symbols long. A "shortened" code is created by taking only S ($S < N$) information symbols as input, appending a fixed string of length $N-S$ and then encoding in the normal way. This fixed string is called "fill" Since the fill is a predetermined sequence of symbols, it need not be transmitted over the channel. Instead, the decoder appends the same fill sequence before decoding. In this case, the fill is called "Virtual Fill".

(Blank page)

11754:2003(E)

CCSDS RECOMMENDATION FOR TELEMETRY CHANNEL CODING

ANNEX D

INFORMATIVE REFERENCES

(This annex is **not** part of the Recommendation.)

- [D1] *Procedures Manual for the Consultative Committee for Space Data Systems*. CCSDS A00.0-Y-7. Yellow Book. Issue 7. Washington, D.C.: CCSDS, November 1996.
- [D2] *Channel Coding—Summary of Concept and Rationale*. Report Concerning Space Data System Standards, CCSDS 100.0-G-2. Green Book. Issue 2. Washington, D.C.: CCSDS, [under development].
- [D3] M. Perlman and J. Lee. *Reed-Solomon Encoders—Conventional vs. Berlekamp's Architecture*. JPL Publication 82-71. Pasadena, California: NASA-Jet Propulsion Laboratory, December 1982.

(Blank page)

.....

CCSDS RECOMMENDATION FOR TELEMETRY CHANNEL CODING

ANNEX E

COMPATIBLE FRAME¹ LENGTHS FOR CCSDS CODEBLOCKS

(This annex is **not** part of the Recommendation.)

E1 PURPOSE

The purpose of this annex is to summarize the length constraints on frames imposed by the use of the Channel Codes specified in this Recommendation.

NOTES

- 1 Recommendations [1] and [2] require that any Transfer Frame or VCDU not operating on a channel using the Reed-Solomon Code of Section 4 must include a Cyclic Redundancy Check (CRC) to be included to provide validation. It follows that a frame on an uncoded channel must also carry the CRC.
- 2 None of the coding techniques recommended (except for the rate=1/2 convolutional code with the inverter) can by itself guarantee sufficient transitions to keep receiver symbol synchronizers in lock. Unless the data, coding, or modulation technique chosen can guarantee sufficient transitions, the pseudo-randomizer is required by Section 6 of this recommendation.

E2 FRAME LENGTHS WITH CONVOLUTIONAL CODING

The Convolutional Codes of Section 2 are not block-oriented codes, so they impose no constraint on the length of the transfer frame or VCDU. However, other length constraints specified in [1] and [2] must still be observed.

¹ *Frame*, as used in this annex, includes the Telemetry “Transfer Frame” as defined in [1] and the AOS “Virtual Channel Data Unit” (VCDU) as defined in [2].

CCSDS RECOMMENDATION FOR TELEMETRY CHANNEL CODING

E3 FRAME LENGTHS WITH REED-SOLOMON CODING

E3.1 GENERAL

With the Reed-Solomon Codes specified in Section 3, only certain specific lengths of transfer frames may be contained within the codeblock’s data space. In some cases these lengths may be shortened in discrete steps by using virtual fill at a small sacrifice in coding gain. Since these R-S codes have a symbol length of 8 bits, the length of the codeblock must be a combined multiple of 8 bits and the interleaving depth. This will give “octet compatibility”. If high-speed efficiency is needed for “32-bit compatibility” (with 32-bit processors, for example) then the length of the codeblock must be a combined multiple of 8 bits, the interleaving depth, and 32 bits.

NOTES

- 1 The Advanced Orbiting Systems Recommendation [2] specifies a limited set of codeblock lengths, and only the E=16 case for the channel code. It is undergoing revision by the CCSDS to include the E=8 option.
- 2 In each table below, lengths are given in bits with equivalent octets in (parentheses).

E3.2 TRANSFER FRAMES FOR OCTET COMPATIBILITY, E=16

The following are allowed lengths for Transfer Frames when octet compatibility is sufficient and the Reed-Solomon E=16 code is selected. Maximum lengths are shown; shorter lengths are permitted in discrete steps using the concept of “Virtual Fill” and shortening the transmitted codeblock length by the steps shown in the last column.

Reed-Solomon Interleave Depth (I)	Maximum Transfer Frame Length	Maximum Transmitted Codeblock Length, E=16	Transfer Frame (and transmitted codeblock) may be shortened in multiples of
1	1784 (223)	2040 (255)	8 (1)
2	3568 (446)	4080 (510)	16 (2)
3	5352 (669)	6120 (765)	24 (3)
4	7136 (892)	8160 (1020)	32 (4)
5	8920 (1115)	10200 (1275)	40 (5)

CCSDS RECOMMENDATION FOR TELEMETRY CHANNEL CODING

E3.3 TRANSFER FRAMES FOR OCTET COMPATIBILITY, E=8

The following are allowed lengths for Transfer Frames when octet compatibility is sufficient and the Reed-Solomon E=8 code is selected. Maximum lengths are shown; shorter lengths are permitted in discrete steps using the concept of “Virtual Fill” and shortening the transmitted codeblock length by the steps shown in the last column.

R-S Inter-leave Depth (I)	Maximum Transfer Frame Length	Maximum Transmitted Codeblock Length, E=8	Transfer Frame (and transmitted codeblock) may be further shortened in multiples of
1	1912 (239)	2040 (255)	8 (1)
2	3824 (478)	4080 (510)	16 (2)
3	5736 (717)	6120 (765)	24 (3)
4	7648 (956)	8160 (1020)	32 (4)
5	9560 (1195)	10200 (1275)	40 (5)

E4 FRAME LENGTHS WITH TURBO CODING

The Turbo Codes specified in Section 4 of this Recommendation are block codes. Therefore, the frame length must match the information block lengths for the selected turbo code.

Performance for only the following information block lengths have been validated by CCSDS and approved for use. These lengths will accommodate both Version 1 Transfer Frames [1] and Version 2 VCDUs [2]. Values are in bits.

1784, 3568, 7136, 8920, 16384¹

NOTES

- 1 Frame synchronizers should be set to account for the Attached Sync Marker, whose length must be added to the turbo codeblock length as specified in Table 4-2. The ASM pattern and length depend on the turbo code rate as shown in Figure 4-4.
- 2 Recommendations [1] and [2] require that if the Reed-Solomon Code is not used, a Cyclic Redundancy Check (CRC) is required as part of the Transfer Frame or VCDU for validation purposes.

¹ Interleaver parameters for the length 16384 bits are under study by the CCSDS. Until finalized, use of this option is not recommended.

ICS 49.140

Price based on 47 pages