

# INTERNATIONAL STANDARD

# ISO 11727

First edition  
1999-05-01

---

---

## **Pneumatic fluid power — Identification of ports and control mechanisms of control valves and other components**

*Transmissions pneumatiques — Identification des orifices et des  
mécanismes de commande des distributeurs de commande et autres  
composants*



Reference number  
ISO 11727:1999(E)

## Contents

|   |           |
|---|-----------|
| <b>1 Scope</b> .....  | <b>1</b>  |
| <b>2 Normative reference</b> .....  | <b>1</b>  |
| <b>3 Terms and definitions</b> .....  | <b>1</b>  |
| <b>4 General principles</b> .....   | <b>3</b>  |
| <b>5 Directional control valves</b> .....                                       | <b>3</b>  |
| <b>5.1 Use of single-digit identification numbers</b> .....                     | <b>3</b>  |
| <b>5.2 Use of two-digit identification numbers</b> .....                        | <b>3</b>  |
| <b>5.3 Manifold port identifications</b> .....                                  | <b>5</b>  |
| <b>5.4 External pilot supply port identification</b> .....                      | <b>6</b>  |
| <b>5.5 Pilot exhaust ports identification</b> .....                             | <b>6</b>  |
| <b>6 Quick exhaust, shuttle and lockout valves</b> .....                        | <b>6</b>  |
| <b>7 Shut-off valves</b> .....  | <b>6</b>  |
| <b>8 Flow control valves, non-return (check) valves and relief valves</b> ..... | <b>6</b>  |
| <b>9 Pressure regulators and filter-regulators</b> .....                        | <b>7</b>  |
| <b>10 Filters, lubricators and ancillary units</b> .....                        | <b>7</b>  |
| <b>11 Examples</b> .....  | <b>7</b>  |
| <b>12 Identification statement</b> .....  | <b>7</b>  |
| <b>Annex A (informative) Symbols giving examples of identification</b> .....    | <b>8</b>  |
| <b>Bibliography</b> .....   | <b>11</b> |

© ISO 1999

All rights reserved. Unless otherwise specified, no part of this publication may be reproduced or utilized in any form or by any means, electronic or mechanical, including photocopying and microfilm, without permission in writing from the publisher.

International Organization for Standardization  
Case postale 56 • CH-1211 Genève 20 • Switzerland  
Internet iso@iso.ch

Printed in Switzerland

## Foreword

ISO (the International Organization for Standardization) is a worldwide federation of national standards bodies (ISO member bodies). The work of preparing International Standards is normally carried out through ISO technical committees. Each member body interested in a subject for which a technical committee has been established has the right to be represented on that committee. International organizations, governmental and non-governmental, in liaison with ISO, also take part in the work. ISO collaborates closely with the International Electrotechnical Commission (IEC) on all matters of electrotechnical standardization.

International Standards are drafted in accordance with the rules given in the ISO/IEC Directives, Part 3.

Draft International Standards adopted by the technical committees are circulated to the member bodies for voting. Publication as an International Standard requires approval by at least 75 % of the member bodies casting a vote.

International Standards ISO 11727 was prepared by Technical Committee ISO/TC 131, *Fluid power systems*, Subcommittee SC 5, *Control products and components*.

Annex A of this International Standard is for information only.

## Introduction

In pneumatic fluid power systems, power is transmitted and controlled through a gas under pressure within a circuit. Flow is directed through and blocked from selected passages in the several components of a pneumatic system. Identification of the ports and the control mechanisms permits the user to properly connect components in a system when using a circuit diagram.

# Pneumatic fluid power — Identification of ports and control mechanisms of control valves and other components

## 1 Scope

**1.1** This International Standard includes rules for identifying and marking ports in pneumatic directional control valves. These ports are the main flow connections, control connections and pilot supply connections.

**1.2** This International Standard includes rules for identifying and marking electrical leads for solenoids. It is not applicable to internal electrical connections across manifold sections, such as connections to bus systems.

**1.3** This International Standard includes rules for identifying and marking control mechanisms of directional control valves.

**1.4** This International Standard includes rules for identifying and marking ports and/or flow path directions in filters, regulators, lubricators, non-return (check) valves, flow control valves and other ancillary devices.

**1.5** This International Standard does not include rules for identifying and marking ports on proportional pneumatic valves, air logic valves, cylinders, air motors, semi-rotary actuators, air compressors, air dryers or other devices not specifically described in this International Standard.

## 2 Normative reference

The following normative document contains provisions which, through reference in this text, constitute provisions of this International Standard. For dated references, subsequent amendments to, or revisions of, any of these publications do not apply. However, parties to agreements based on this International Standard are encouraged to investigate the possibility of applying the most recent edition of the normative document indicated below. For undated references, the latest edition of the normative document referred to applies. Members of ISO and IEC maintain registers of currently valid International Standards.

ISO 5598, *Fluid power systems and components — Vocabulary*.

## 3 Terms and definitions

For the purposes of this International Standard, the terms and definitions given in ISO 5598 and the following apply.

### 3.1

#### **control mechanism**

device that provides an input signal to a component (e.g. lever, solenoid)

NOTE The terms "operator" and "actuator" have sometimes been used for this definition, but the term "control mechanism" is preferred.

### 3.2

#### **pilot control port**

port that is subject to a change in pressure, usually an applied pressure signal from an external source, that produces a change in state of the component under control

**3.3  
external pilot supply port**

port that receives a continuous, uninterrupted supply of pressure from an external source for use by a control mechanism

**3.4  
main ports**

ports in a component that are either connected to one another or blocked upon actuation by the control mechanism

**3.5  
solenoid lead**

electrical wires directly attached to a solenoid winding

**3.6  
electric lead**

electrical wires communicating with an electrically operated valve that are used for field connections.

NOTE These might not be directly attached to a solenoid winding when the valve has electrical circuitry or other internal connections.

**3.7  
normally closed (NC) valve**

valve that, in its normal position (as defined in ISO 5598), has its inlet port closed

**3.8  
normally open (NO) valve**

valve that, in its normal position (as defined in ISO 5598), has its inlet port connected to its outlet port

**3.9  
diverter valve**

3/2 directional control valve with a single inlet port that can divert flow to either of two separate outlet ports

**3.10  
selector valve**

3/2 directional control valve with a single outlet port, flow to which can be selected from either of two separate inlet ports

**3.11  
lockout valve**

manually controlled valve that has two operating positions

NOTE The first position allows normal passage of pressurized fluid into a machine or system. The second prevents the passage of fluid from the inlet and allows a discharge of the pressurized fluid from a machine or system. The control device is capable of being locked, by a key or combination padlock, in the second position only.

**3.12  
identification**

means of reference to be used in descriptive literature or on a label associated with a component

**3.13  
mark**

means of reference to be applied directly on the component

**3.14  
pilot exhaust port**

exhaust port associated with a control mechanism which provides an exhaust or relief function which is not part of the actual control function

**3.15****3/2 normally open optional valve**

3/2 directional control valve supplied as a normally closed valve, and marked or identified as such, but constructed so that the inlet and exhaust connection can be interchanged to provide a normally open mode of operation

**3.16****5/2 optional dual pressure valve**

5/2 directional control valve with standard main port identification, but which is constructed so that the exhaust ports 5 and 3 can be used as separate inlets and the normal inlet port 1, used as a common exhaust port

**4 General principles**

**4.1** The numerals used in this International Standard are the principal means of port identification based on the precedence established in ISO 5599-1, ISO 5599-2 and ISO 5599-3. Some exceptions are defined for pilot supply ports in valves and for flow direction arrows in two-ported devices.

**4.2** Main ports are identified by single-digit numbers.

**4.3** Control mechanisms, the pilot control ports and their electrical leads are identified by double-digit numbers. The first of these digits is the number one (1) and the second digit is the main port that communicates with main port 1 when the correspondingly numbered control mechanism is actuated. If the control mechanism causes main port 1 to become blocked, a zero (0) is used as the second digit.

NOTE 1 Other flow paths may exist or become blocked as a result of a control mechanism actuation, in addition to the flow path related to main port 1. These may be determined from the graphic symbol for the valve.

NOTE 2 The principle in 4.3, however, does not apply to the centre position of three-position valves or to mechanical/manual control mechanisms that have multiple independent positions.

**4.4** Port locations and control mechanism locations are not required to occupy any specific position on a component. Their physical location relative to graphic symbols on a drawing also need not correspond.

**5 Directional control valves****5.1 Use of single-digit identification numbers**

Use the single-digit identification numbers as listed in Table 1 to identify and mark the main ports. Marking shall be placed next to the ports on the component or on labels that are located to identify the ports.

**5.2 Use of two-digit identification numbers**

Use the two-digit identification numbers as listed in Table 1 to identify and, if desired, mark the control mechanisms and to identify and mark the pilot control ports (if any exist), plus the solenoid leads (if any exist — see 5.2.1).

Table 1 — Valve port and control mechanism identifications

| Valve type <sup>a</sup> | Description  | Main ports |           |            | Control mechanisms, pilot control ports, solenoid and electrical leads |
|-------------------------|--|------------|-----------|------------|--|
|                         |  | Inlet(s)   | Outlet(s) | Exhaust(s) |  |
| 2/2                     | Two-port   | 1          | 2         | —          | 12, 10   |
| 3/2 NC                  | Three-port NC                                      | 1          | 2         | 3          | 12, 10   |
| 3/2 NO                  | Three-port NO                                      | 1          | 2         | 3          | 12, 10   |
| 3/2 NO                  | (Optional) <sup>b</sup>                            | 3          | 2         | 1          | 12, 10   |
| 3/2                     | Diverter   | 2          | 1, 3      | —          | 12, 10   |
| 3/2                     | Selector   | 1, 3       | 2         | —          | 12, 10   |
| 4/2 & 4/3               | Four-port  | 1          | 2, 4      | 3          | 12, 14   |
| 5/2 & 5/3               | Five-port  | 1          | 2, 4      | 3, 5       | 12, 14   |
| 5/2 & 5/3               | Five-port <sup>b</sup><br>(Optional dual pressure) | 3, 5       | 2, 4      | 1          | 12, 14   |

<sup>a</sup> The first number refers to the number of main ports and the second to the number of valve positions. For example, a 2/2 valve is a two-main-port, two-position valve, and a 4/3 valve is a four-main-port, three-position valve. The term "way" has also been used in descriptions of valves, and expressions such as "three-way valves" and "four-way valves" have been common. Confusion can arise with four-way, four-port and four-way, five-port valves, each with two or three positions. Because of this, the use of the term "way" in descriptions of valves is strongly discouraged.

<sup>b</sup> The optional arrangement is identified either from the graphic symbol or from instructions included with the valve's packaging.

**5.2.1** Electrical leads shall be identified by one of the following means, according to the examples in Figure 1 a), b) and c) below (other combinations are also possible):

- visual observation of solenoid leads directly connected to the control mechanism (no marking or colour code required);
- colour-coded electrical wiring at the field connection, with instructions directly on the valve, identifying the control mechanism associated with the colour code;
- markings on the terminal block or on the electrical wiring, using the identification numbers described in Table 1, identifying the control mechanism associated with the markings.



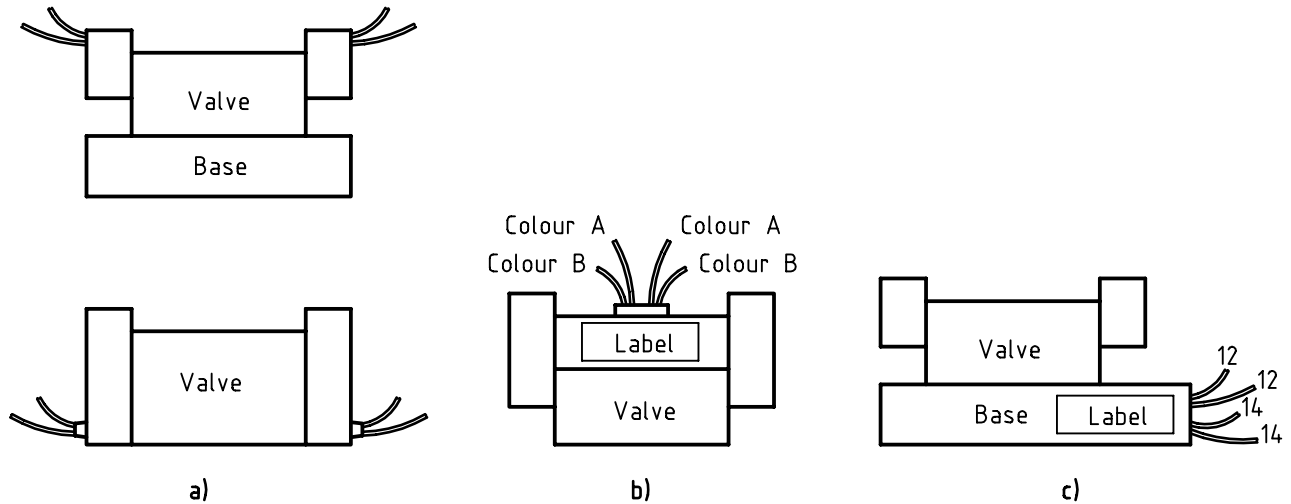
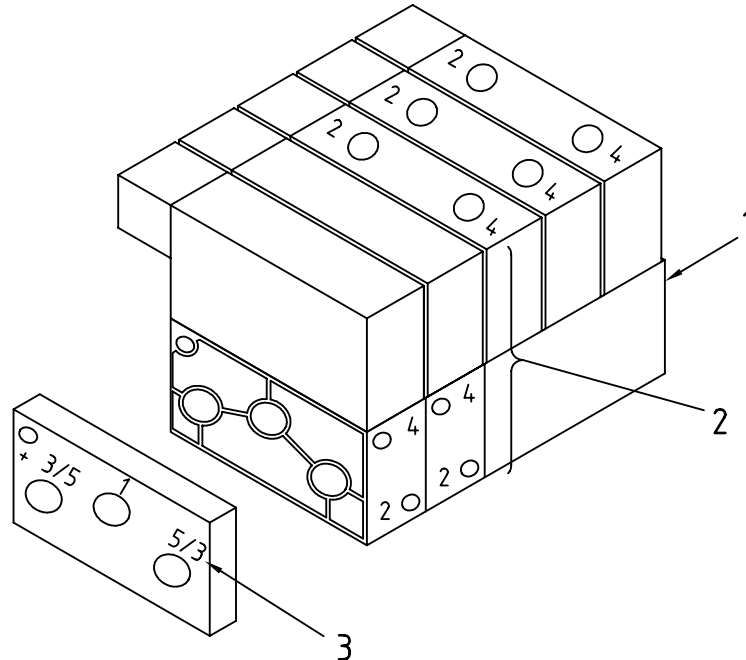

**Figure 1 — Examples of identification of electrical leads**

**5.2.2** Control mechanisms need not be marked but should be identifiable from instructional material or from the label attached to the valve. If a label uses a graphic symbol to identify the control mechanisms, the symbol should be oriented to correspond with the control mechanisms' locations. Control mechanisms may also be identified by association with the pilot control port near them.

**5.3 Manifold port identifications**

**5.3.1** Sections of a manifold or manifold assembly shall use the same identifications as described in Table 1 for those main ports, pilot control ports, control mechanisms and solenoid/electrical leads that are externally connected in sections of a manifold or manifold assembly. See Figure 2.



**Key**

- 1) Port markings on manifold end if no end plate is used
- 2) Section of a manifold (with one piece base) or a manifold assembly (with individual bases), which includes valve, control mechanism and base
- 3) Port markings on end plate if used on manifold assembly (optional, dual marking shown)

**Figure 2 — Example of identification on a manifold or manifold assembly**

**5.3.2** End plates and/or end surfaces of a manifold or manifold assembly shall use the same identifications as described in Table 1 for main ports and pilot control ports. If main ports have multiple functions or an identification that depends upon its assembly location on the manifold ends, then multiple identifications are optional for the ports (see Figure 2).

## 5.4 External pilot supply port identification

Instructional material shall describe the external pilot supply port application.

**5.4.1** Valve designs that allow the use of pilot control ports for the external pilot supply port may use the control port identifications and describe the arrangements or adjustments necessary in instructional material.

**5.4.2** Valves with a separate external pilot supply port, or manifold valves with an external pilot supply port at the manifold end, should use the identifier "X".

## 5.5 Pilot exhaust ports identification

Pilot exhaust ports need not be marked.

## 6 Quick exhaust, shuttle and lockout valves

These devices are essentially 3/2 valves with internal pilot control for quick exhaust and shuttle valves, and with manual control for lockout valves. Their main ports shall be identified and marked as follows:

Quick exhaust and lockout: inlet port - 1  
 outlet port - 2  
 exhaust port - 3

Shuttle: inlet ports - 1 and 3; or two ports - 1  
 outlet port - 2

## 7 Shut-off valves

These devices are 2/2 valves and, where the direction of flow is not important for valve functioning, no port identification and marking is required.

Where the direction of flow is important to the correct functioning of the valve, two options are permitted:

- a) the inlet port shall be identified and marked "1" and the outlet port "2"; or
- b) instead of numbers, the products may be marked with an arrow that indicates the direction of flow from the inlet port to the outlet port.

## 8 Flow control valves, non-return (check) valves and relief valves

These devices are all two-port valves with various control mechanisms. A graphic symbol oriented in the direction of its function and located on the product is preferred. The main ports shall be identified and marked as follows:

- inlet port - 1;
- exhaust or outlet port - 2.

Relief valves with an exhaust passage that is not designed for a connection need not have any port markings.

## 9 Pressure regulators and filter-regulators

One of the following options shall be selected for inlet and outlet ports:

- a) the inlet port shall be identified and marked "1" and the outlet port as "2"; or
- b) instead of numbers, these products may be marked with an arrow to indicate the flow direction from the inlet to the outlet.

A relief port shall be identified and marked "3". A relief hole may be identified as "3" but it does not need to be marked. A pressure regulator with a pilot control shall identify the control port as "12", but it does not need to be marked.

## 10 Filters, lubricators and ancillary units

One of the following options shall be selected for inlet and outlet ports:

- a) inlet ports shall be identified and marked "1" and outlet ports as "2"; or
- b) instead of numbers, these products may be marked with an arrow to indicate flow direction from the inlet to the outlet.

Drain ports, where they exist, may be identified "L" but do not need to be marked.

## 11 Examples

Annex A provides symbols (in accordance with ISO 1219-1) that give examples of the identifications defined in this International Standard.

## 12 Identification statement (Reference to this International Standard)

Use the following statement in test reports, catalogues and sales literature when electing to comply with International Standard:

"Ports and control mechanisms of pneumatic control valves and other components identified in accordance with ISO 11727:1999, *Pneumatic fluid power — Identification of ports and control mechanisms of control valves and other components.*"

## Annex A (informative)

### Symbols giving examples of identification

#### Directional control valves

2/2 valve

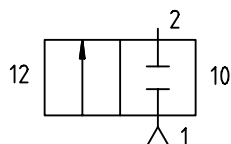

3/2 NC valve

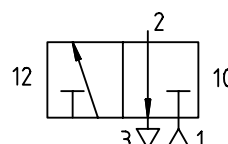

3/2 NO valve

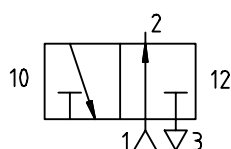

3/2 NO optional valve

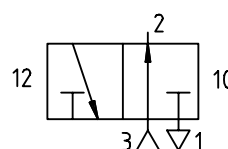

3/2 diverter valve

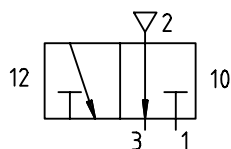

3/2 selector valve

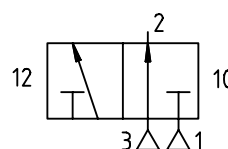

4/2 valve

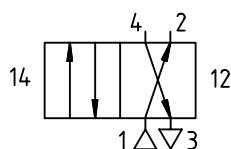

4/3 valve

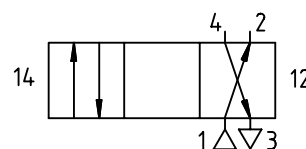

5/2 valve

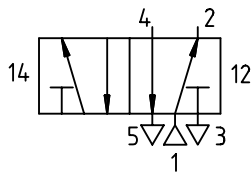

5/2 optional dual pressure valve

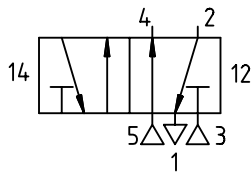

5/3 valve

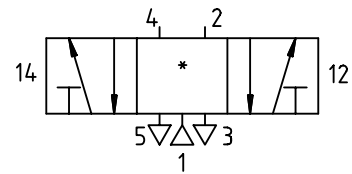

5/3 optional dual pressure valve

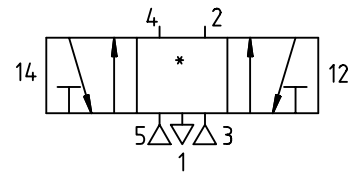

(\*) Centre position may be: (a) all ports blocked ;  
 (b) port 1 connected to ports 2 and 4, plus ports 3 and 5 blocked ;  
 (c) port 1 blocked, plus port 2 connected to 3 and port 4 connected to 5.

**Auxiliary valves**

Quick exhaust valve

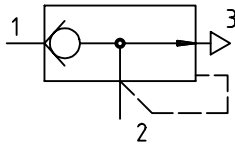

Lockout valve

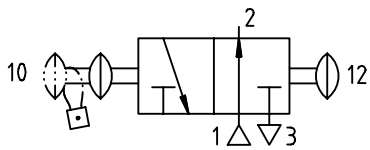

Flow control valve

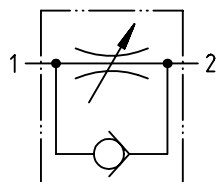

Shuttle valve

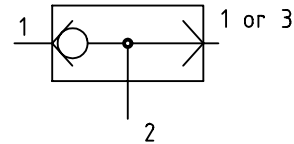

Shut-off valve

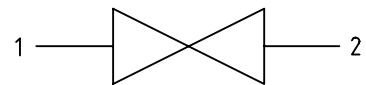

Non-return (check) valve

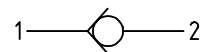

Relief valve

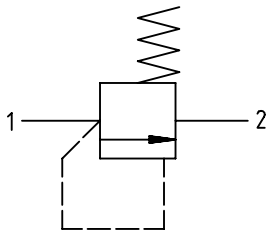

**Compressed air conditioning units**

Pressure regulator

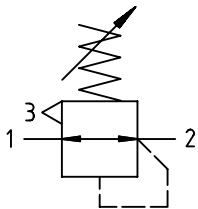

Pilot pressure

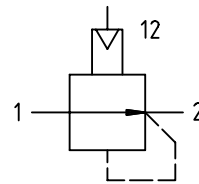

Filter

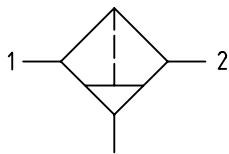

Filter-regulator

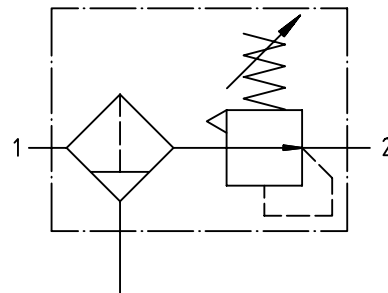

Lubricator

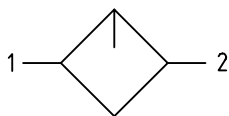

## Bibliography

- [1] ISO 1219-1:1991, *Fluid power systems and components — Graphic symbols and circuit diagrams — Part 1: Graphic symbols.*
- [2] ISO 5599-1:1989, *Pneumatic fluid power — Five-port directional control valves — Part 1: Mounting interface surfaces without electrical connector.*
- [3] ISO 5599-2:1990, *Pneumatic fluid power — Five-port directional control valves — Part 2: Mounting interface surfaces with optional electrical connector.*
- [4] ISO 5599-3:1990, *Pneumatic fluid power — Five-port directional control valves — Part 3: Code system for communication of valve functions.*

.....

---

---

**ICS 23.100.50**

Price based on 11 pages

---

---