

INTERNATIONAL
STANDARD

ISO
11724

Second edition
2016-12-01

Solid mineral fuels — Determination of total fluorine in coal, coke and fly ash

*Combustibles minéraux solides — Détermination de la teneur totale
en fluor dans le charbon, le coke et les cendres*



Reference number
ISO 11724:2016(E)



COPYRIGHT PROTECTED DOCUMENT

© ISO 2016, Published in Switzerland

All rights reserved. Unless otherwise specified, no part of this publication may be reproduced or utilized otherwise in any form or by any means, electronic or mechanical, including photocopying, or posting on the internet or an intranet, without prior written permission. Permission can be requested from either ISO at the address below or ISO's member body in the country of the requester.

ISO copyright office
Ch. de Blandonnet 8 • CP 401
CH-1214 Vernier, Geneva, Switzerland
Tel. +41 22 749 01 11
Fax +41 22 749 09 47
copyright@iso.org
www.iso.org

Contents

Page

Foreword	iv
1 Scope	1
2 Normative references	1
3 Terms and definitions	1
4 Principle	1
5 Reagents	1
6 Apparatus	2
7 Sample	5
7.1 Coal and coke.....	5
7.2 Fly ash.....	5
8 Procedure	5
8.1 Number of determinations.....	5
8.2 Preparation of test sample.....	5
8.3 Blank tests.....	5
8.4 Pyrohydrolysis procedure.....	5
8.4.1 Apparatus conditioning.....	5
8.4.2 Pyrohydrolysis.....	5
8.4.3 Pyrohydrolysate processing.....	6
8.5 Solution measurement.....	6
8.5.1 General.....	6
8.5.2 Direct-comparison ISE method.....	6
8.5.3 Analyte-addition ISE method.....	7
8.5.4 IC method.....	7
9 Calculations	8
9.1 General.....	8
9.2 Direct-comparison ISE method.....	8
9.3 Analyte-addition ISE method.....	9
9.4 IC method.....	9
10 Expression of result	9
11 Precision	10
11.1 Repeatability limit.....	10
11.2 Reproducibility critical difference.....	10
12 Test report	10
Bibliography	11

Foreword

ISO (the International Organization for Standardization) is a worldwide federation of national standards bodies (ISO member bodies). The work of preparing International Standards is normally carried out through ISO technical committees. Each member body interested in a subject for which a technical committee has been established has the right to be represented on that committee. International organizations, governmental and non-governmental, in liaison with ISO, also take part in the work. ISO collaborates closely with the International Electrotechnical Commission (IEC) on all matters of electrotechnical standardization.

The procedures used to develop this document and those intended for its further maintenance are described in the ISO/IEC Directives, Part 1. In particular the different approval criteria needed for the different types of ISO documents should be noted. This document was drafted in accordance with the editorial rules of the ISO/IEC Directives, Part 2 (see www.iso.org/directives).

Attention is drawn to the possibility that some of the elements of this document may be the subject of patent rights. ISO shall not be held responsible for identifying any or all such patent rights. Details of any patent rights identified during the development of the document will be in the Introduction and/or on the ISO list of patent declarations received (see www.iso.org/patents).

Any trade name used in this document is information given for the convenience of users and does not constitute an endorsement.

For an explanation on the meaning of ISO specific terms and expressions related to conformity assessment, as well as information about ISO's adherence to the World Trade Organization (WTO) principles in the Technical Barriers to Trade (TBT) see the following URL: www.iso.org/iso/foreword.html.

The committee responsible for this document is ISO/TC 27, *Solid mineral fuels*, Subcommittee SC 5, *Methods of analysis*.

This second edition cancels and replaces the first edition (ISO 11724:2004), of which it constitutes a minor revision. This document incorporates changes related to dated references and other minor items following its systematic review.

Solid mineral fuels — Determination of total fluorine in coal, coke and fly ash

1 Scope

This document specifies a method for the determination of total fluorine in coal, coke and fly ash.

From measurement of the total fluorine alone, it is not possible to estimate the amount of fluorine released to the environment by utilization of the coal and subsequent disposal of the ash residue.

2 Normative references

The following documents are referred to in the text in such a way that some or all of their content constitutes requirements of this document. For dated references, only the edition cited applies. For undated references, the latest edition of the referenced document (including any amendments) applies.

ISO 589, *Hard coal — Determination of total moisture*

ISO 687, *Solid mineral fuels — Coke — Determination of moisture in the general analysis test sample*

ISO 5068-2, *Brown coals and lignites — Determination of moisture content — Part 2: Indirect gravimetric method for moisture in the analysis sample*

ISO 5069-2, *Brown coals and lignites — Principles of sampling — Part 2: Sample preparation for determination of moisture content and for general analysis*

ISO 11722, *Solid mineral fuels — Hard coal — Determination of moisture in the general analysis test sample by drying in nitrogen*

ISO 13909-4, *Hard coal and coke — Mechanical sampling — Part 4: Coal — Preparation of test samples*

ISO 13909-6, *Hard coal and coke — Mechanical sampling — Part 6: Coke — Preparation of test samples*

3 Terms and definitions

No terms and definitions are defined in this document.

ISO and IEC maintain terminological databases for use in standardization at the following addresses:

- IEC Electropedia: available at <http://www.electropedia.org/>
- ISO Online browsing platform: available at <http://www.iso.org/obp>

4 Principle

Mixing of the sample of coal, coke or fly ash with silica, and pyrohydrolysis in a tube furnace at approximately 1 200 °C in an atmosphere of oxygen and water vapour. Absorption of the volatilized fluorine compounds in a suitable solution and processing for determination by ion-selective electrode (ISE) or ion chromatographic (IC) techniques.

5 Reagents

CAUTION — Care shall be exercised when handling reagents, some of which are toxic and corrosive.

ISO 11724:2016(E)

During the analysis, use only reagents of recognized analytical grade and only distilled water, or water of equivalent purity.

5.1 Silica of top size 75 µm, ignited at 1 000 °C for 1 h.

CAUTION — Fine silica is dangerous to health if inhaled.

5.2 Solutions for ISE measurement

5.2.1 Standard fluorine solution (1 g contains 200 µg of F).

a) For direct-comparison method

Dissolve 0,221 0 g ± 0,000 2 g of dry (110 °C for 1 h) sodium fluoride in approximately 400 ml of water contained in a tared plastic bottle, dilute to 500 g ± 0,5 g net with water, and mix.

b) For analyte-addition method

Dissolve 0,221 0 g ± 0,000 2 g of dry (110 °C for 1 h) sodium fluoride in a tared plastic bottle containing 150 ml of water and 100 g of buffer (5.2.3). Dilute to 500 g ± 0,5 g net with water and mix.

5.2.2 Absorption solution (0,025 mol/l NaOH).

Dissolve 2,0 g of sodium hydroxide in about 500 ml of water. Transfer to a tared 2,5 l plastic bottle, dilute to 2 000 g net with water, and mix.

5.2.3 Buffer (pH 6,5).

Dissolve 10,0 g of potassium nitrate, 5 g of 1,2-cyclohexylenedinitrilotetraacetic acid (CDTA) and 115 g of ammonium acetate in 350 ml of water. Adjust the pH to 6,5 with glacial acetic acid. Dilute to 500 g net with water and mix.

5.2.4 Solution for conditioning fluoride ISE.

Weigh 20 g of water, 20 g of absorption solution (5.2.2) and 10 g of buffer (5.2.3) into a polystyrene vial (6.2). Add approximately 200 mg of standard fluorine solution [of 5.2.1 a) or 5.2.1 b)] and mix.

5.3 Solutions for IC measurement

5.3.1 Standard fluorine solution (1 g contains 200 µg of F).

Dissolve 0,221 0 ± 0,000 2 g of dry (110 °C for 1 h) sodium fluoride in approximately 400 ml of water contained in a tared plastic bottle, dilute to 500 g ± 0,5 g net with water, and mix.

5.3.2 Absorption solution for IC measurement.

Dissolve 0,300 g of sodium hydrogen carbonate and 1,120 g of sodium carbonate in approximately 500 ml of water and dilute to 2 l.

5.4 Oxygen, compressed.

6 Apparatus

6.1 Vials, made of glass or polystyrene, of capacity 10 ml to 30 ml with tightly fitting snap-on plastic caps.

6.2 Polypropylene bottles or polystyrene vials, tared, of capacity 125 ml, wide necked with linerless leak-proof screw caps.

6.3 Balances: a balance capable of weighing to the nearest 0,000 1 g; a balance capable of weighing approximately 200 g to the nearest 0,001 g; a balance capable of weighing 600 g to the nearest 0,01 g; and a balance capable of weighing 3 000 g to the nearest 0,1 g.

6.4 Polyethylene dispensing bottles, for the standard fluorine solution (5.2.1), absorption solution (5.2.2) and buffer (5.2.3).

6.5 Micropipette, of variable volume, ranging to at least 1 ml.

This is a satisfactory alternative to the 250 ml polyethylene dispensing bottle (6.4) for delivery of small weighed volumes of standard fluorine solution (5.2.1).

6.6 Apparatus for tube-furnace pyrohydrolysis (see Figure 1).

6.6.1 Steam generator, consisting of the following:

- a) round-bottom flask, 2 l capacity;
- b) heating mantle, 2 l capacity;
- c) Y-piece, glass, 10 mm diameter;
- d) oxygen distribution tube, porosity 0;
- e) stopcocks, one three-way and one two-way.

6.6.2 Silica-tube furnace and accessories.

The apparatus is similar to that used in ISO 351.

- a) **Silica tube**, made of pure silica (25 mm outer diameter, 20 mm inner diameter), of length (typically 700 mm) appropriate to the particular furnace used (generally of an approximate length of 400 mm). Preferably, the gas outlet end should be narrowed to a tubule of approximately 7 mm diameter.

NOTE Combustion tubes of alternative refractory compositions do not have adequate thermal stress characteristics for operation with this method.

- b) **Silicone stoppers**, 20 mm diameter, positioned at inlet end (and outlet, if applicable) of the silica tube described in a).
- c) **Combustion boats**, made of high-alumina unglazed porcelain (approximately 97 mm × 16 mm × 12 mm), preignited at 1 000 °C for 1 h.
- d) **Silica pusher and T-tube**, comprising a silica push rod (5 mm diameter and 500 mm long) fused at one end to provide a flat disc surface of 10 mm to 12 mm diameter, and having a piece of magnetic steel affixed to the other end by epoxy resin. The T-tube (500 mm long) is composed of borosilicate glass and protrudes 10 mm into the silica tube a) through a stopper b). The stem of the T-tube is connected to the steam generator by way of the three-way stopcock [6.6.1 e)]. A magnet is used to move the pusher inside the T-tube.
- e) **Combustion furnace**, capable of reaching a temperature of at least 1 200 °C.

6.6.3 Absorption vessel: Dreschel gas washing bottle or equivalent, of capacity 125 ml, with gas-distribution tube fitted with a sintered glass disc of 15 µm to 40 µm pore size [6.6.1 d)] bent at 90°, approximately 60 mm from the top.

6.6.4 **Water jacket**, suitable for containing the absorption vessel.

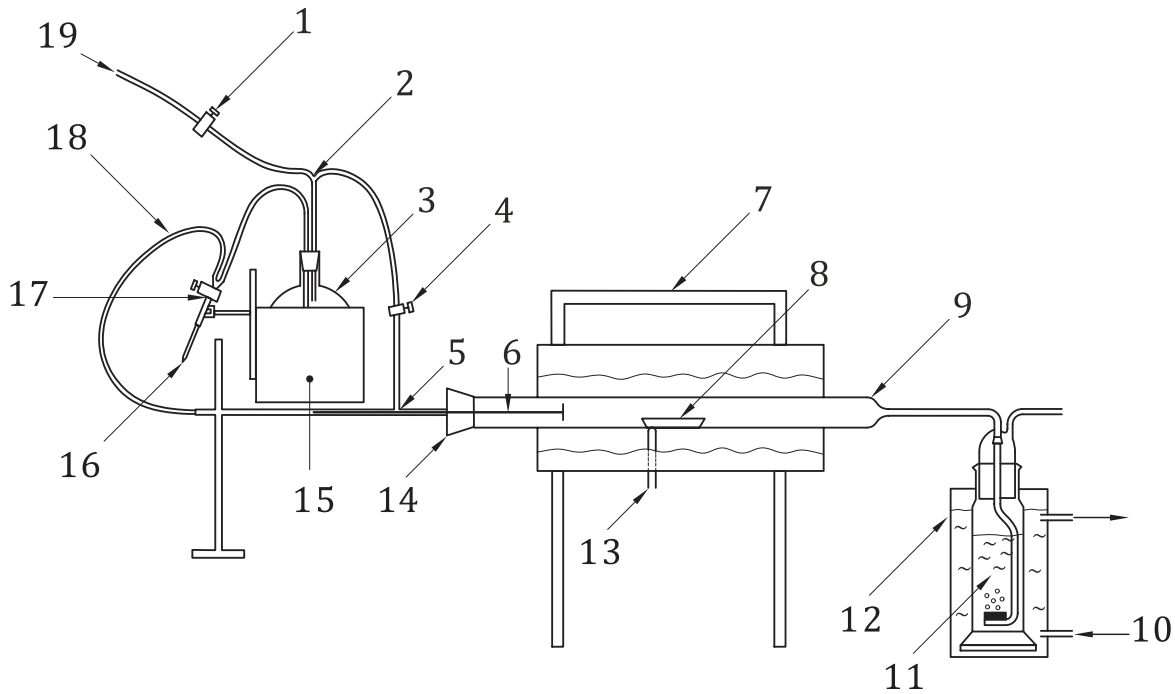

Key

- | | | |
|----------------------|----------------------|----------------------------|
| 1 stopcock | 8 combustion boat | 15 heating mantle |
| 2 Y-piece | 9 silica tube | 16 oxygen in |
| 3 round-bottom flask | 10 cooling water | 17 three-way stopcock |
| 4 stopcock | 11 absorption vessel | 18 steam distribution tube |
| 5 T-piece | 12 water jacket | 19 to sink |
| 6 silica pusher | 13 thermocouple | |
| 7 furnace | 14 silicone stopper | |

Figure 1 — Schematic diagram of pyrohydrolysis apparatus

6.7 ISE measurement apparatus

6.7.1 Magnetic stirrer, complete with polytetrafluoroethylene stirring bars.

6.7.2 Electrodes: a solid state fluoride ion selective electrode and a reference electrode.

The sensing element of the fluoride electrode should be polished on each day of use to prolong optimal performance. This may be achieved, for example, by using 0,25 mm diamond dust or alumina sprayed on a polishing cloth, and polishing the electrode for 30 s to 60 s. The electrode, having been stored dry, is conditioned for at least 30 min prior to use, by insertion in a conditioning solution (5.2.4).

6.7.3 Millivoltmeter, having a resolution of 0,1 mV.

6.8 IC measurement apparatus, equipped with a chromatography pump, anion separation columns, conductivity detector and integrator.

7 Sample

7.1 Coal and coke

The test sample is the general analysis sample prepared in accordance with ISO 5069-2, ISO 13909-4 or ISO 13909-6, as appropriate.

7.2 Fly ash

Fly ash normally has a top particle size of less than 75 μm and therefore may not require any reduction prior to analysis. However, special care shall be taken in the collection and preparation of representative samples and in avoiding contamination.

8 Procedure

8.1 Number of determinations

The analysis should be carried out in duplicate on separate test portions of the coal, coke or fly ash.

8.2 Preparation of test sample

The test sample mass taken for the analysis is dependent upon the mass fraction of fluorine present. The following procedure assumes mass fractions of fluorine up to a maximum of 2 000 $\mu\text{g/g}$. If higher fluorine mass fractions are anticipated or found to be present, proportionately lower sample masses shall be taken to ensure maximal recovery of fluorine from the sample matrix.

Accurately weigh 250 mg, to the nearest 0,1 mg, of the coal, coke or fly ash (this is the sample mass, m_s) and mix well with 250 mg \pm 5 mg of silica (5.1) in a vial (6.1). If calculation to bases other than as-received is required, concurrently weigh another sample for determination of the moisture in the coal, coke or fly ash by one of the methods specified in ISO 589, ISO 11722, ISO 5068-2 or ISO 687, as appropriate.

8.3 Blank tests

Blank tests should be carried out in duplicate with each batch of test samples.

8.4 Pyrohydrolysis procedure

8.4.1 Apparatus conditioning

To the round-bottom flask [6.6.1 a)], add a few boiling chips and 1 600 ml of water. Allow the steam generator to achieve gentle boiling. Connect an absorption vessel (6.6.3) containing about 50 ml of water. With the furnace, set at an operational temperature of 1 200 $^{\circ}\text{C}$, pass oxygen through the steam generator into the furnace at approximately 750 ml/min for 15 min.

To minimize condensation of steam, the silica tube should be positioned inside the furnace, so that less than 100 mm protrudes at the outlet end. The oxygen flow and the temperature of steam generation should be adjusted so that approximately 40 g of condensate is collected during 18 min of pyrohydrolysis.

To avoid excessive warping of the silica tube, the temperature should not rise above 1 225 $^{\circ}\text{C}$.

8.4.2 Pyrohydrolysis

Add 50 ml \pm 1 ml of appropriate absorption solution (5.2.2 or 5.3.2) to the absorption vessel (6.6.3). Secure to the outlet of the combustion tube assembly {silicone rubber tubing and glass-silica contact if a tubular outlet combustion tube [6.6.2 a)] is used}. Position the water jacket around the absorption vessel and ensure an adequate flow of cooling water.

ISO 11724:2016(E)

Transfer the sample/silica mixture from the vial (6.1) to a combustion boat.

Allow oxygen to flow, by-passing the steam generator, at 750 ml/min into the furnace. Place the test sample boat into the inlet end of the combustion tube so that it is approximately 200 mm from the centre of the hottest zone. Reconnect the silica pusher and T-tube and, after 1 min, redirect the oxygen flow through the steam generator into the combustion tube. At five subsequent intervals of approximately 30 s, push the test sample boat forward about 40 mm, withdrawing the silica pusher each time to prevent its distortion. At the last push, the boat should be at the centre of the hottest zone.

For certain coals, which liberate volatile matter at a high rate, the early stage of heating may produce a carry-over of carbon particles. For such coals, the rate of pushing shall be reduced.

Continue the pyrohydrolysis for a further 15 min.

The water level in the flask [6.6.1 a)] should be maintained in the range 700 ml to 1 600 ml.

8.4.3 Pyrohydrolysate processing

At the completion of the pyrohydrolysis time, redirect the oxygen flow around the steam generator and allow excess steam to escape to the sink.

Disconnect the absorption vessel from the combustion tube and rinse down the gas distribution tube.

Rinse the pyrohydrolysate into a tared polypropylene bottle (6.2) with a small amount of water and allow to cool to room temperature.

With an oxygen flow of 750 ml/min and the correct heating rate on the steam generator, the total mass of pyrohydrolysate at this stage should be approximately 90 g.

Place the pyrohydrolysate on the balance and, for ISE measurement only, add approximately 0,75 g (m_1) of standard fluorine solution [5.2.1 a)] by means of a dispensing bottle (6.4) or adjustable micropipette (6.5); the increase in mass (m_1) allows calculation of the amount of fluorine added.

Dilute with water to 100 g \pm 0,1 g (m_2) and mix. Otherwise record the mass of pyrohydrolysate and mix.

For the ISE method, transfer about 40 g of pyrohydrolysate, weighed to the nearest 0,02 g (m_a), to a tared polystyrene vial (6.2). Calculate the mass (approximately 10 g) of buffer (5.2.3) needed to achieve a buffer concentration of 20 % (m/m), and add within 0,05 g of this amount (m_b), of buffer with the aid of a top-loading balance (6.3) and a dispensing bottle (6.4). Seal the vial and set aside for ISE measurement.

8.5 Solution measurement

8.5.1 General

In this clause, procedures are described for pyrohydrolysis followed by direct-comparison ISE, analyte-addition ISE or IC measurement.

To minimize drift, ISE measurements should be made under constant illumination and at a constant temperature.

8.5.2 Direct-comparison ISE method

To each of four tared 125 ml bottles (6.2), add 50,0 ml \pm 1 ml of absorption solution (5.2.2), label the bottles S1, S2, S3 and S4, and add 500 mg \pm 5 mg, 1 000 mg \pm 10 mg, 1 500 mg \pm 15 mg and 2 000 mg \pm 20 mg, respectively, of standard fluorine solution [5.2.1 a)] weighed to the nearest milligram. Dilute with water to 100,0 g \pm 0,05 g net and mix. The mass fraction of fluorine in these solutions is 1 μ g/g, 2 μ g/g, 3 μ g/g and 4 μ g/g. Add an exactly measured amount of buffer (5.2.3) to approximately 40 g of each of these solutions, in the same way as for the samples (8.4.3).

Allow the solution to reach ambient temperature before measurement. Place a stirring bar in the solution and a thermal insulation mat between the vial and the magnetic stirrer. Remove the electrodes (6.7.2) from the stirred conditioning solution (5.2.4) and dry with a filter paper. Stir the measurement solution for 5 s to 10 s before inserting the electrode(s) to a depth of 20 mm and dislodging any air bubbles from the sensing element of the electrode. Record the potential (to the nearest 0,1 mV) after 2 min to 3 min.

This reading should not change by more than 0,1 mV during the next 2 min, provided that the sensing element has been polished (see 6.7.2) and the reference electrode is functioning properly and contains fresh filling solution.

Remove the electrode(s) from the measurement solution, briefly rinse with water into a waste beaker, and insert into the stirred conditioning solution (5.2.4) for at least 30 s before removing and inserting into the next measurement solution, as described above.

The electrodes are subject to minor drift throughout the batch of measurements, and some significant improvements in accuracy and precision are achieved by monitoring this drift. Proceed with readings by reading S2 before any other solution. Read S1, S3, S4 then S2 again. Subsequently, read S2 after every four processed pyrohydrolysate solutions, and finally again at the completion of the batch. (Linear adjustments of the bracketed sample/standard/blank solution measurements are then possible to achieve optimal data quality.)

8.5.3 Analyte-addition ISE method

Have the electrodes ready in the stirred conditioning solution (5.2.4).

Determine the slope of the electrode (S) in accordance with the information supplied by the manufacturer.

Proceed as described in paragraph 2 of 8.5.2. Record the potential after 2 min to 3 min to the nearest 0,1 mV (E_1).

With the aid of a top-loading balance (6.3) and a polyethylene dispensing bottle (6.4) or other suitable device, add between 0,5 g and 3 g (m_d measured to the nearest milligram) of standard fluorine solution [5.2.1 b)], so that the meter reading falls by 20 mV to 30 mV. After 2 min or 3 min, record the potential, to the nearest 0,1 mV (E_2).

Remove the electrode(s) from the measurement solution, briefly rinse with water into a waste beaker and insert into the stirred conditioning solution (5.2.4) for at least 30 s before removing and inserting into the next measurement solution as in paragraph 3 above.

8.5.4 IC method

Weigh, to the nearest milligram, 100 mg \pm 1 mg, 200 mg \pm 2 mg, 400 mg \pm 4 mg and 800 mg \pm 8 mg of standard fluorine solution [5.2.1 a)] into four tared 125 ml bottles or vials (6.2). Add 50 ml of absorption solution (5.3.2) and accurately dilute to 100 g (\pm 0,1 g) net mass. The mass fraction of fluorine in these solutions is 0,2 μ g/g, 0,4 μ g/g, 0,8 μ g/g and 1,6 μ g/g.

Proceed with measurements according to the instrument manufacturer's recommendations.

NOTE Samples having mass fractions of fluorine exceeding the calibration range require dilution and matrix matching.

9 Calculations

9.1 General

Depending upon the particular procedure used to measure the amount of fluorine in the pyrohydrolysate, one of the equations outlined in subsequent clauses will be required. In each case, the mass of fluorine is calculated for each sample and blank test solution, and the mass fraction of fluorine in the sample is calculated using [Formula \(1\)](#):

$$w_{F,ad} = \frac{m_S - m_{F(blank)}}{m_S} \quad (1)$$

where

- $w_{F,ad}$ is the mass fraction of fluorine, in micrograms per gram, in the sample;
- $m_{F(blank)}$ is the mass, in micrograms, of fluorine in blank test pyrohydrolysate;
- m_S is the mass, in grams, of sample taken for pyrohydrolysis.

9.2 Direct-comparison ISE method

Using the data obtained for the calibration solutions, graph the logarithm of mass fraction of fluorine against potential, in millivolts.

NOTE As the 4 + 1 dilution is equivalent for calibration solutions and sample solutions, this dilution is ignored in the subsequent calculations.

From the graph, obtain the mass fraction, $w_{F,2}$, of fluorine using [Formula \(2\)](#):

Then

$$m_F = w_{F,2}m_2 - w_{F,1}m_1 \quad (2)$$

where

- m_F is the mass, in micrograms, of fluorine in sample or blank test pyrohydrolysate;
- $w_{F,2}$ is the mass fraction, in micrograms per gram, of fluorine in the sample solution, obtained from the graph;
- m_2 is the mass, in grams, of the sample of pyrohydrolysate (100,0 g);
- $w_{F,1}$ is the mass fraction, in micrograms per gram, of standard fluorine solution [[5.2.1 a](#)] = 200 µg/g (from the method);
- m_1 is the mass, in grams, of standard fluorine addition [[5.2.1 a](#)] added to the pyrohydrolysate.

9.3 Analyte-addition ISE method

Calculate the mass of fluorine using [Formula \(3\)](#):

$$m_F = \frac{wm_d m_2}{m_a \left[1 + \frac{m_d}{(m_a + m_b)} \right] 10^{\frac{(E_1 - E_2)}{S}} - 1} - wm_1 \quad (3)$$

where

- m_F is the mass, in micrograms, of fluorine in sample or blank test pyrohydrolysate;
- w is the mass fraction, in micrograms per gram, (200 µg/g) of standard fluorine solutions, [\[5.2.1 a\)](#) and [5.2.1 b\)](#)];
- m_2 is the mass, in grams, of sample or blank test pyrohydrolysate;
- m_d is the mass, in grams, of standard fluorine solution [\[5.2.1 b\)](#)] added to achieve potential E_2 ;
- m_a is the mass, in grams, of aliquot of pyrohydrolysate;
- m_b is the mass, in grams, of buffer added to aliquot;
- E_1 is the initial potential, in millivolts, of buffered spiked pyrohydrolysate;
- E_2 is the final potential, in millivolts, of buffered spiked pyrohydrolysate after addition of standard fluorine solution;
- S is the slope, in millivolts per decade concentration, of the electrode at the temperature of measurement;
- m_1 is the mass, in grams, of standard fluorine solution [\[5.2.1 a\)](#)] added in [8.4.3](#).

9.4 IC method

Using the data obtained for the calibration solutions, graph the mass fraction of fluorine in the pyrohydrolysate versus the IC instrument response (e.g. peak height or peak area). From the graph, obtain $w_{F,2}$, the mass fraction of fluorine in sample or blank test pyrohydrolysate. Then

$$m_F = w_{F,2} m_2 \quad (4)$$

where

- m_F is the mass, in micrograms, of fluorine in sample or blank test pyrohydrolysate;
- $w_{F,2}$ is the mass fraction, in micrograms per gram, of fluorine in sample or blank test pyrohydrolysate;
- m_2 is the mass, in grams, of sample or blank test pyrohydrolysate (100,0 g).

10 Expression of result

The result, the mean of duplicate determinations, shall be reported to the precision indicated in [Table 1](#).

Table 1 — Reporting of result

Magnitude of result $\mu\text{g/g}$	Reporting precision $\mu\text{g/g}$
<500	nearest 5
≥ 500	nearest 10

The results of the determination described in this document are reported on the air-dry basis. Calculation of results to other bases is dealt with in ISO 1170.

11 Precision

11.1 Repeatability limit

The results of duplicate determinations, carried out at different times in the same laboratory by the same operator with the same apparatus on representative portions taken from the same analysis sample, shall not differ by more than the values given in [Table 2](#).

11.2 Reproducibility critical difference

The means of the results of duplicate determinations, carried out in each of two laboratories on representative portions taken from the same sample after the last stage of sample preparation, shall not differ by more than the values given in [Table 2](#).

Table 2 — Precision data for fluorine

Mass-fraction range $\mu\text{g/g}$	Repeatability $\mu\text{g/g}$	Reproducibility
≤ 200	10	20 $\mu\text{g/g}$
> 200	20	15 % ^a
^a Percentage value quoted is relative to the mean result.		

12 Test report

The test report shall include the following information:

- a) identification of the sample tested;
- b) the method used, by reference to this document, i.e. ISO 11724;
- c) the date of the test;
- d) the results of the determination and the method of expression used.

Bibliography

- [1] ISO 351¹⁾, *Solid mineral fuels — Determination of total sulfur — High temperature combustion method*
- [2] ISO 1170, *Coal and coke — Calculation of analyses to different bases*

1) Withdrawn.

