**Carbonaceous materials used in the
production of aluminium — Cathode blocks
and baked anodes — Determination of
electrical resistivity at ambient temperature**

*Produits carbonés utilisés pour la production de l'aluminium — Blocs
cathodiques et anodes cuites — Détermination de la résistivité électrique à
la température ambiante*



Reference number
ISO 11713:2000(E)

© ISO 2000

PDF disclaimer

This PDF file may contain embedded typefaces. In accordance with Adobe's licensing policy, this file may be printed or viewed but shall not be edited unless the typefaces which are embedded are licensed to and installed on the computer performing the editing. In downloading this file, parties accept therein the responsibility of not infringing Adobe's licensing policy. The ISO Central Secretariat accepts no liability in this area.

Adobe is a trademark of Adobe Systems Incorporated.

Details of the software products used to create this PDF file can be found in the General Info relative to the file; the PDF-creation parameters were optimized for printing. Every care has been taken to ensure that the file is suitable for use by ISO member bodies. In the unlikely event that a problem relating to it is found, please inform the Central Secretariat at the address given below.

© ISO 2000

All rights reserved. Unless otherwise specified, no part of this publication may be reproduced or utilized in any form or by any means, electronic or mechanical, including photocopying and microfilm, without permission in writing from either ISO at the address below or ISO's member body in the country of the requester.

ISO copyright office
Case postale 56 • CH-1211 Geneva 20
Tel. + 41 22 749 01 11
Fax + 41 22 734 10 79
E-mail copyright@iso.ch
Web www.iso.ch

Printed in Switzerland

Foreword

ISO (the International Organization for Standardization) is a worldwide federation of national standards bodies (ISO member bodies). The work of preparing International Standards is normally carried out through ISO technical committees. Each member body interested in a subject for which a technical committee has been established has the right to be represented on that committee. International organizations, governmental and non-governmental, in liaison with ISO, also take part in the work. ISO collaborates closely with the International Electrotechnical Commission (IEC) on all matters of electrotechnical standardization.

International Standards are drafted in accordance with the rules given in the ISO/IEC Directives, Part 3.

Draft International Standards adopted by the technical committees are circulated to the member bodies for voting. Publication as an International Standard requires approval by at least 75 % of the member bodies casting a vote.

Attention is drawn to the possibility that some of the elements of this International Standard may be the subject of patent rights. ISO shall not be held responsible for identifying any or all such patent rights.

International Standard ISO 11713 was prepared by Technical Committee ISO/TC 47, *Chemistry*, Subcommittee SC 7, *Aluminium oxide, cryolite, aluminium fluoride, sodium fluoride, carbonaceous products for the aluminium industry*.

Carbonaceous materials used in the production of aluminium — Cathode blocks and baked anodes — Determination of electrical resistivity at ambient temperature

1 Scope

This International Standard specifies a method for the determination of the electrical resistivity of cathode blocks and baked anodes used in the production of aluminium, using samples at ambient temperature.

2 Normative references

The following normative documents contain provisions which, through reference in this text, constitute provisions of this International Standard. For dated references, subsequent amendments to, or revisions of, any of these publications do not apply. However, parties to agreements based on this International Standard are encouraged to investigate the possibility of applying the most recent editions of the normative documents indicated below. For undated references, the latest edition of the normative document referred to applies. Members of ISO and IEC maintain registers of currently valid International Standards.

ISO 8007-1:1999, *Carbonaceous materials used in the production of aluminium — Sampling plans and sampling from individual units — Part 1: Cathode blocks.*

ISO 8007-2:1999, *Carbonaceous materials used in the production of aluminium — Sampling plans and sampling from individual units — Part 2: Prebaked anodes.*

3 Principle

A fixed, constant direct current is passed through a sample of given cross-section. The voltage drop between sensors is measured and the electrical resistivity is calculated.

4 Apparatus

4.1 Drilling machine, equipped with a diamond-tipped drill.

4.2 Cutter, with a diamond-coated disk.

4.3 Slide calliper, accurate to $\pm 0,5$ %.

4.4 Ammeter, accurate to $\pm 0,5$ %.

4.5 Potentiometer, or **digital voltmeter**, class of accuracy IEC 0,5 %.

4.6 Sample clamping device, equipped with a current supply and voltage sensors which may be points or blades with a radius of curvature not less than 200 μm . For blades the sensors shall be perpendicular to the axis of the sample.

4.7 Oven, capable of being maintained at (110 ± 5) °C.

4.8 Apparatus for the determination of electrical resistivity, (see Figure 1) in which the contact surface between the current supply and the sample has a ratio of

$$\frac{d}{D} \geq \frac{2}{3}$$

where

d is the diameter of the current supply contactor;

D is the diameter or width of the sample;

and

- the distance of the voltage sensors from the edge of the sample is greater than $0,5 D$, and at least 30 mm;
- the distance between the voltage sensors is greater than $0,8 D$, and at least 40 mm;
- the contact force of the contactor of the current supply is not less than 50 N;
- the contact force of the voltage sensors on the specimen is not less than 0,5 N.

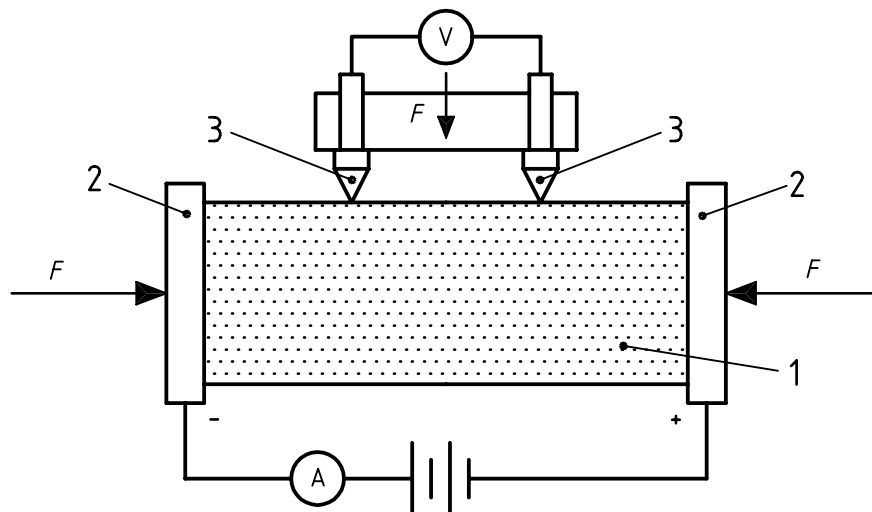

F = Force of 50 N

Key

- 1 Test specimen
- 2 Current supply contactor
- 3 Voltage sensors

Figure 1 — Principle for resistivity measurements

5 Sampling

Sample the cathode blocks and baked anodes in accordance with ISO 8007-1 and ISO 8007-2.

6 Procedure

6.1 Preparation of specimens

Note the direction of sampling (see ISO 8007-2:1999) and take test samples of cylindrical or cuboid shape with the following minimum dimensions. All dimensions shall be greater than or equal to three times the maximum particle size of the dry aggregate:

- diameter of a cylindrical sample: 30 mm minimum;
- or
- square cross-section: 30 mm × 30 mm minimum;
- length of the sample: 100 mm minimum;
- variation of the cross-section in the measuring zone: 0,5 % max.

Dry the sample in the oven (4.7) at (110 ± 5) °C for at least 2 h, then leave to cool.

6.2 Determination

Clean the current contactor and the voltage sensors to ensure optimum electrical contact.

Determine the mean diameter or mean side of the specimen with the slide calliper (4.3) in the vicinity of the voltage sensors on two perpendicular diameters in the case of a cylinder and on the four sides in case of a cuboid.

Determine the distance, l , between the points of the voltage sensors to within $\pm 0,5$ %.

Place the test specimen between the current contactors and apply force of 50 N so as to ensure optimum distribution of current.

Adjust the direct current so as to obtain a current density which is not greater than 1 A/cm².

Put the voltage sensors into place.

Measure the current and difference in voltage on the four radii of the cylinder or on the four sides of the cuboid by rotating the test specimen 90°.

Ensure that the time during which the current passes through the test is sufficiently short to prevent any detectable change in resistance.

7 Calculation

The resistivity of the specimen, ρ , expressed in micro-ohm metres, is given by the equation

$$\rho = \frac{U \cdot A}{I \cdot l} \times 10^4$$

where

U is the difference in voltage, in volts, over length l ;

A is the area of the cross-section, in square centimetres, of the test specimen;

I is the current intensity, in amperes;

l is the distance, in centimetres, between the voltage sensors.

Calculate the result to the nearest integer for values greater than $20 \mu\Omega \cdot \text{m}$ and to one decimal place for values less than $20 \mu\Omega \cdot \text{m}$.

8 Precision

8.1 Repeatability, r

$$r = 1,2 \mu\Omega \cdot \text{m}$$

8.2 Reproducibility, R

$$R = 1,5 \mu\Omega \cdot \text{m}$$

9 Test report

The test report shall contain the following information:

- a) a complete identification of the test sample;
- b) a reference to this International Standard, i.e. ISO 11713;
- c) the results and the units in which they are expressed;
- d) any unusual features noted during the determination;
- e) any operations not included in this International Standard or in the International Standards to which reference is made, or regarded as optional.

ICS 71.100.10

Price based on 4 pages

© ISO 2000 – All rights reserved