

INTERNATIONAL STANDARD

ISO 11602-2

First edition
2000-07-01

Fire protection — Portable and wheeled fire extinguishers —

Part 2: Inspection and maintenance

*Protection contre l'incendie — Extincteurs portatifs et extincteurs
sur roues —*

Partie 2: Contrôle et maintenance



Reference number
ISO 11602-2:2000(E)

© ISO 2000

PDF disclaimer

This PDF file may contain embedded typefaces. In accordance with Adobe's licensing policy, this file may be printed or viewed but shall not be edited unless the typefaces which are embedded are licensed to and installed on the computer performing the editing. In downloading this file, parties accept therein the responsibility of not infringing Adobe's licensing policy. The ISO Central Secretariat accepts no liability in this area.

Adobe is a trademark of Adobe Systems Incorporated.

Details of the software products used to create this PDF file can be found in the General Info relative to the file; the PDF-creation parameters were optimized for printing. Every care has been taken to ensure that the file is suitable for use by ISO member bodies. In the unlikely event that a problem relating to it is found, please inform the Central Secretariat at the address given below.

© ISO 2000

All rights reserved. Unless otherwise specified, no part of this publication may be reproduced or utilized in any form or by any means, electronic or mechanical, including photocopying and microfilm, without permission in writing from either ISO at the address below or ISO's member body in the country of the requester.

ISO copyright office
Case postale 56 • CH-1211 Geneva 20
Tel. + 41 22 749 01 11
Fax + 41 22 749 09 47
E-mail copyright@iso.ch
Web www.iso.ch

Printed in Switzerland

Contents

	Page	
1	Scope	1
2	Normative references	1
3	Terms and definitions	1
4	Inspection, maintenance and recharging.....	2
4.1	General.....	2
4.2	Inspection.....	2
4.3	Maintenance	3
4.4	Recharging	6
4.5	Records.....	8
5	Hydrostatic proof-pressure tests	8
5.1	General.....	8
5.2	Frequency.....	9
5.3	Test pressures	9
Annex A	(normative) Competent persons	10
A.1	General.....	10
A.2	Training and experience of a competent person.....	10
Annex B	(normative) Proof-pressure testing	11
B.1	General.....	11
B.2	Test equipment	11
B.3	Test procedures	11
B.4	Recording of tests	13
B.4.1	High-pressure types	13
B.4.2	Low-pressure types	13
Annex C	(normative) Obsolete extinguishers	15
Annex D	(informative) Hazard types.....	16

Foreword

ISO (the International Organization for Standardization) is a worldwide federation of national standards bodies (ISO member bodies). The work of preparing International Standards is normally carried out through ISO technical committees. Each member body interested in a subject for which a technical committee has been established has the right to be represented on that committee. International organizations, governmental and non-governmental, in liaison with ISO, also take part in the work. ISO collaborates closely with the International Electrotechnical Commission (IEC) on all matters of electrotechnical standardization.

International Standards are drafted in accordance with the rules given in the ISO/IEC Directives, Part 3.

Draft International Standards adopted by the technical committees are circulated to the member bodies for voting. Publication as an International Standard requires approval by at least 75 % of the member bodies casting a vote.

Attention is drawn to the possibility that some of the elements of this part of ISO 11602 may be the subject of patent rights. ISO shall not be held responsible for identifying any or all such patent rights.

International Standard ISO 11602-2 was prepared by Technical Committee ISO/TC 21, *Equipment for fire protection and fire fighting*, Subcommittee SC 2, *Manually transportable fire extinguishers*.

ISO 11602 consists of the following parts, under the general title *Fire protection — Portable and wheeled fire extinguishers*:

- *Part 1: Selection and installation*
- *Part 2: Inspection and maintenance*

Annexes A, B and C form a normative part of this part of ISO 11602. Annex D is for information only.

Fire protection — Portable and wheeled fire extinguishers —

Part 2: Inspection and maintenance

1 Scope

This part of ISO 11602 specifies the inspection, maintenance, and periodic testing of portable and wheeled fire extinguishers.

Portable fire extinguishers are intended as a first line of defence against fires of limited size. They are needed, even if the property is equipped with automatic sprinklers, standpipe and hose, or other fixed protection equipment.

This part of ISO 11602 is not applicable to permanently installed systems for fire extinguishment, even though portions of such systems may be portable (such as hose and nozzles attached to a fixed supply of extinguishing media).

Extinguishers for use on board aircraft, watercraft and vehicles are considered to be outside the scope of this part of ISO 11602.

2 Normative references

The following normative documents contain provisions which, through reference in this text, constitute provisions of this part of ISO 11602. For dated references, subsequent amendments to, or revisions of, any of these publications do not apply. However, parties to agreements based on this part of ISO 11602 are encouraged to investigate the possibility of applying the most recent editions of the normative documents indicated below. For undated references, the latest edition of the normative document referred to applies. Members of ISO and IEC maintain registers of currently valid International Standards.

ISO 5923, *Fire protection — Fire extinguishing media — Carbon dioxide.*

ISO 7201-1, *Fire protection — Fire extinguishing media — Halogenated hydrocarbons — Part 1: Specifications for halon 1211 and halon 1301.*

ISO 7201-2, *Fire extinguishing media — Halogenated hydrocarbons — Part 2: Code of practice for safe handling and transfer procedures of halon 1211 and halon 1301.*

ISO 11602-1, *Fire protection — Portable and wheeled fire extinguishers — Part 1: Selection and Installation.*

3 Terms and definitions

For the purposes of this part of ISO 11602, the terms and definitions given in ISO 11602-1 apply.

4 Inspection, maintenance and recharging

4.1 General

4.1.1 The owner or designated agent or occupant of a property in which extinguishers are located shall be responsible for inspection, maintenance and recharging.

4.1.2 The procedure for inspection and maintenance of extinguishers varies considerably. Minimal knowledge is necessary to perform a monthly inspection procedure as outlined in 4.2. Only competent persons shall service extinguishers, as outlined in 4.3 and 4.4. See annex A.

4.1.3 Maintenance and recharging shall be performed in accordance with the appropriate manual(s), using the proper types of tools, recharge materials, lubricants, and the manufacturer's recommended and identified replacement parts.

4.1.4 Extinguishers out of service for maintenance or recharge shall be replaced at once by spare extinguishers of the same type and at least equal classification and rating.

4.2 Inspection

4.2.1 Extinguishers shall be checked when initially placed in service and thereafter should be checked at approximately 30-day intervals. Extinguishers shall be checked at more frequent intervals when circumstances require.

4.2.2 Periodic checks shall be made to ensure that the extinguisher:

- a) is located in the designated place;
- b) is unobstructed and visible, and its operating instructions face outwards;
- c) operating instructions are legible;
- d) seals and tamper indicators are not broken or missing;
- e) is full (by weighing or lifting);
- f) is not obviously damaged, corroded, leaking or has a clogged nozzle;
- g) where provided, the pressure gauge reading or indicator is in the operable range or position.

4.2.3 When a check of any extinguisher reveals a deficiency in the conditions listed as a) and b) of 4.2.2, immediate corrective action shall be taken.

4.2.4 When a check of any rechargeable extinguisher reveals a deficiency in any of the conditions c), d), e), f) or g) of 4.2.2, it shall be subjected to appropriate maintenance procedures.

4.2.5 When a check of any non-rechargeable powder extinguisher reveals a deficiency in any of the conditions c), d), e), f) or g) of 4.2.2, it shall be removed from service.

4.2.6 When a check of any non-rechargeable halon extinguisher reveals a deficiency in any of the conditions c), d), e), f) or g) of 4.2.2, it shall be removed from service and the medium shall be recovered or destroyed.

4.3 Maintenance

4.3.1 General

All extinguishers, except as noted in annex C, shall be subjected to maintenance as follows:

- a) not more than once a year but not less than 6 months apart;
- b) at the time of hydrostatic testing; and
- c) when specifically indicated by an inspection.

Maintenance procedures shall be performed in accordance with 4.3.2.

4.3.2 All extinguishers

4.3.2.1 At each maintenance, all extinguishers shall be subjected to the following:

- a) a check of the seal and safety device to determine whether the extinguisher may have been used;
- b) subsequent to maintenance, replacement of the safety device and fitting of a new seal;
- c) attachment of a label to the extinguisher or marking of a label attached to the extinguisher indicating that the required maintenance has been performed.

4.3.2.2 For the balance of the procedures to be carried out when maintaining portable fire extinguishers, extinguisher types are categorized as follows:

- Category 1: stored-pressure-type extinguishers with water, water with additives, or foam, as the extinguishing media;
- Category 2: stored-pressure-type extinguishers with powder or halon as the extinguishing media;
- Category 3: gas-cartridge-type extinguishers with water, water with additives, or foam as the extinguishing media;
- Category 4: gas-cartridge-type extinguishers with powder as the extinguishing media;
- Category 5: carbon dioxide extinguishers.

4.3.2.3 In addition to the requirements of 4.3.2.1 a), b) and c), extinguishers shall be maintained as shown in Table 1.

4.3.2.4 CAUTION: Before any powder extinguisher is opened, it shall be ascertained that, during inspection and maintenance, the precautions described in 4.3.2.4.1 and 4.3.2.4.2 can and will be observed.

4.3.2.4.1 Powder extinguishers shall be opened only in the driest available conditions and for the minimum time necessary for examination, to minimize the effect of atmospheric moisture on the powder (powder may absorb deleterious amounts of moisture if exposed to air of high relative humidity, or if the powder is colder than the ambient air).

4.3.2.4.2 Mixing or cross-contamination of different types of powder shall be avoided. (Some types of powder are capable of reacting with other types to produce water and carbon dioxide. This reaction often does not become apparent until after a delay of weeks during which no apparent reaction occurs. The water causes caking and, in a closed container, the carbon dioxide causes a pressure rise that can be dangerous. Only extinguishers containing the same powder should be opened and examined at any one time.)

Table 1

Ref. No.	Maintenance procedure	Category				
		1	2	3	4	5
1	Examine and verify that the pressure indicating device (if fitted) is reading the internal pressure correctly or, where a device is not fitted, that the internal pressure is correct. If the extinguisher shows a loss of pressure of more than 10 %, or more than the manufacturer's recommended maximum loss if less than 10 %, refer to the manufacturer's instructions for appropriate action.	X	X			
2	Examine the extinguisher body externally for corrosion or damage. If the extinguisher is slightly corroded, or has sustained minor damage, it shall be discarded or subjected to hydrostatic testing. If heavily corroded or severely damaged, it shall be discarded.	X	X	X	X	X
3	Weigh the extinguisher (with or without the operating mechanism according to the manufacturer's instructions) or use suitable alternative means to check that it contains the correct mass of medium. Check the mass against the mass recorded when it was first put into service.	X	X	X	X	X
4	Examine the nozzle and hose (if provided) and clean if necessary. Replace if worn or otherwise not in good condition.	X	X	X	X	X
5	Where extinguishers are designed to have the operating mechanism removed, check the operating mechanism and discharge control (where fitted) for free movement. Clean, rectify or replace if necessary. Protect the moving parts and threads against corrosion with a lubricant as recommended by the manufacturer.	X	X	X	X	
6	Open the extinguisher or otherwise remove the head assembly. Remove the gas cartridge.			X	X	
7	(Water with additive, or foam extinguishers only.) Pour the liquid into a clean container. If evidence of deterioration is apparent (refer to manufacturer's instructions regarding specific products), discard the liquid and refill with the manufacturer's specified liquid. Where the foam concentrate or additive is in a separate container, check this for leakage. Discard leaking containers and replace with a new container and charge.			X		
8	Clean the inside and outside of the extinguisher and examine the body externally and internally for corrosion or damage. If the extinguisher is slightly corroded, or has sustained minor damage, it shall be discarded or subjected to hydrostatic testing. If heavily corroded or severely damaged, it shall be discarded.			X		

Table 1 (continued)

Ref. No.	Maintenance procedure	Category				
		1	2	3	4	5
9	Examine the gas cartridge externally for corrosion or damage. If the gas cartridge is damaged or corroded, replace the cartridge as recommended by the manufacturer. Weigh the gas cartridge and check the mass against that marked on the cartridge. A gas cartridge which has a content less than the minimum as marked, or which is found to be leaking, shall be withdrawn from service or replaced by a cartridge as recommended by the manufacturer.			X	X	
10	Clean if necessary and pass air through the vent holes (or other venting device) in the cap.			X	X	
11	Examine the branch pipe (where used) nozzle, strainer and (where fitted) the internal discharge tube and breather valve, and clean if necessary.			X		
12	Clean and examine the nozzle, hose and internal discharge tube for blockage by passing air through them; rectify or replace if necessary.				X	
13	Examine all washers, diaphragms and hose, and replace if damaged or defective. If the hose is fitted at the bottom end of the extinguisher and a diaphragm is used, it shall be replaced.			X	X	
14	Examine the powder in the extinguisher to check that there are no visual signs of caking, lumps or foreign bodies. Agitate the powder by inverting and shaking the extinguisher, taking care to avoid spillage. If there is any evidence of caking, lumps or foreign bodies, if it is not free flowing, or if there is any doubt, discard all the powder, and recharge the extinguisher with the original manufacturer's powder.				X	
15	Return the original charge to the extinguisher, topping up any loss with water, or replacing with fresh water as necessary. For water with additives, or foam, recharge the extinguisher in accordance with the manufacturer's instructions.			X		
16	Re-assemble the extinguisher in accordance with the manufacturer's instructions.			X	X	
17	Examine the horn, hose and valve assembly, and clean and replace if not in good condition.					X
18	Perform a conductivity test on hose assemblies.					X

NOTE In some countries, where it is judged by a competent authority that the quality control procedures and reliability of manufacture of certain dry chemical internal hermetically sealed (welded seal) cartridge-type extinguishers are considered adequate, the first internal examination only may be delayed from the date of manufacturer until required by 4.3.3.5.

4.3.2.5 In addition to the annual maintenance specified in 4.3.1 to 4.3.2.4, the following maintenance, as described in Table 2, shall also be performed at intervals not exceeding five years.

EXCEPTION 1: Non-rechargeable fire extinguishers, other than halon types, shall be discharged and discarded not later than 5 years from their date of manufacture.

EXCEPTION 2: Non-rechargeable fire extinguishers of the halon type, shall be removed from service and returned to a recycling centre for recovery of the halon not later than 5 years from their date of manufacture.

Table 2

Ref. No.	Maintenance procedure	Category		
		1 (5 years)	2 (5 years)	5 (5 years)
1	Discharge the extinguisher completely. After discharge, the zero pressure gauge (where provided) shall indicate zero pressure, and an indicator (where provided) shall shown a discharged position.	X	X	X
2	Open the extinguisher, clean the inside and examine the body internally for corrosion or damage. If the extinguisher is slightly corroded, or has sustained minor damage, it shall be discarded or subjected to hydrostatic testing. If heavily corroded or severely damaged, it shall be discarded.	X	X	X
3	Examine, as appropriate, the nozzle, strainer and hose, vent holes (or other venting device) in the cap or valve assembly, and the internal discharge tube. Clean, if necessary.	X	X	X
4	Examine all sealing washers and hose (if fitted), and replace if defective.	X	X	X
5	Check the operating mechanism for free movement and clean, rectify or replace as necessary.	X	X	X
6	Re-assemble the extinguisher and recharge. See 4.4.	X	X	X

4.3.2.6 Halon extinguishers shall not be discharged to the atmosphere but shall be emptied at intervals not exceeding 5 years by a method that permits recovery of the halon. Following emptying, the additional maintenance as described in Table 2 shall be performed. When emptied, measures should be taken to minimize any emissions of halons into the atmosphere.

4.4 Recharging

4.4.1 All rechargeable-type extinguishers shall be recharged after any use or when indicated by an inspection or maintenance deficiency.

4.4.2 When performing the recharging, the recommendations of the manufacturer shall be followed.

4.4.3 The amount of recharge medium shall be verified by weighing. The recharged gross mass shall be the same as the gross mass that is marked on the manufacturer's label.

For those extinguishers that do not have the gross mass marked on the label, a permanent marking that indicates the gross mass shall appear elsewhere on the extinguisher.

4.4.4 After recharging, a leak test shall be performed on stored pressure and self-expelling media extinguishers and cartridges.

Where liquid leak detection methods are employed, caution shall be exercised to prevent contamination of the media with the liquid.

4.4.5 Aqueous film-forming foam (AFFF) and film-forming fluoroprotein foam (FFFP) extinguishers shall be recharged with fresh media in accordance with the instructions on the extinguisher.

4.4.6 Only the medium specified on the nameplate shall be used.

4.4.7 One powder shall not be mixed or allowed to be contaminated with another powder.

4.4.8 Extinguishers shall not be converted from one type to another, nor shall any extinguisher be converted to use a different type of extinguishing medium.

4.4.9 The remaining powder in a discharged extinguisher shall not be re-used.

4.4.10 Extinguishers removed for 5-year maintenance or hydrostatic testing shall be emptied. The powder shall not be re-used unless a closed recovery system is used and the media separately stored in a sealed container to prevent contamination. Prior to re-use, the powder shall be thoroughly checked. Where doubt exists with respect to the type, contamination or condition of the powder, it shall be discarded.

4.4.11 For all non-water types of extinguishers, any moisture present in the emptied extinguisher shall be removed before recharging.

4.4.12 Halon-type extinguishers shall only be charged with the proper type and mass of medium as specified on the nameplate. Halon for recharging shall meet the requirements of ISO 7201. Extinguishers that have not previously contained halon meeting the requirements of ISO 7201 shall not be recharged.

4.4.13 The removal of media from halon extinguishers shall only be done using a closed recovery system for halon. The extinguisher cylinder shall be examined internally for contamination and/or corrosion. The media retained in the system recovery cylinder shall be re-used only if no evidence of internal contamination is observed in the extinguisher cylinder. Halon removed from extinguishers that exhibit evidence of internal contamination or corrosion shall be processed in accordance with the extinguisher manufacturer's instructions.

4.4.14 Carbon dioxide shall meet the requirements of ISO 5923.

4.4.15 When recharging water-type extinguishers, overfilling will result in improper discharge. The correct amount of liquid medium shall be determined by using one of the following:

- exact measurement by mass;
- exact measurement by volume;
- use of an anti-overfill tube when provided; or
- use of a fill mark, if provided.

4.4.16 Gauges used to set the regulated source of pressure shall be calibrated at least annually.

4.4.17 A rechargeable stored- pressure-type extinguisher shall be pressurized only to the charging pressure specified on the extinguisher nameplate. The manufacturer's pressurizing adaptor shall be connected to the valve assembly before pressurizing the extinguisher. A regulated source of pressure, set to no higher than 0,2 Mpa above the operating (service) pressure, shall be used to pressurize fire extinguishers.

WARNING: An unregulated source of pressure, such as a nitrogen cylinder without a pressure regulator, shall never be used because the extinguisher could be over pressurized and possibly rupture.

Never leave an extinguisher connected to the regulator of a high-pressure source for an extended period of time. A defective regulator could cause the shell to rupture due to excess pressure.

4.4.18 Only standard industrial-grade nitrogen or other inert gas with a dew point of $-55\text{ }^{\circ}\text{C}$ or lower shall be used to pressurize stored pressure powder and halon fire extinguishers. Compressed air through moisture traps shall not be used for pressurizing, even if this is stated in the instructions on older extinguishers.

EXCEPTION 1: Compressed air may be used from special compressor systems capable of delivering air with a dew point of $-55\text{ }^{\circ}\text{C}$ or lower. The special compressor system shall be equipped with an automatic monitoring and alarm system to ensure that the dew point remains at or below $-55\text{ }^{\circ}\text{C}$ at all times.

EXCEPTION 2: Carbon dioxide may be used where so specified on the nameplate. Where carbon dioxide is used, it shall meet the requirements of ISO 5923.

4.5 Records

4.5.1 The maintenance company shall keep records of all extinguishers serviced by their personnel, including the type of service performed.

4.5.2 The date the service was performed and the identification of the organization and person performing the service shall be recorded.

4.5.3 Each extinguisher shall have a tag or label securely attached that indicates the month and year the service (maintenance, recharging and hydrostatic tests) was performed, and this shall identify the person performing the service.

4.5.4 Labels recording service shall not be placed on the front of the extinguisher.

5 Hydrostatic proof-pressure tests

5.1 General

5.1.1 Hydrostatic tests shall be performed by persons trained in pressure-testing procedures and safeguards, and having available suitable testing equipment, facilities and appropriate servicing manual(s) (see annex B).

5.1.2 If, at any time, an extinguisher shows evidence of corrosion or mechanical injury, and is not discarded, it shall be hydrostatically tested, subject to the provisions of 5.1.3 and 5.1.4.

EXCEPTION 1: Non-rechargeable fire extinguishers, other than halon types, shall be discharged and discarded.

EXCEPTION 2: Non-rechargeable halon extinguishers shall be returned to a recycling centre for recovery of the halon.

5.1.3 When an extinguisher cylinder or shell fulfils one or more of the conditions listed in this subclause, it shall not be hydrostatically tested, but shall be destroyed by the owner or at his or her direction:

- a) when there exist repairs by soldering, welding, brazing, or use of patching compounds;
- b) when the cylinder or shell threads are damaged;
- c) when there exists corrosion that has caused pitting;
- d) when the extinguisher has been burned in a fire;
- e) when a calcium chloride type of extinguishing medium has been used in a stainless-steel extinguisher;
- f) when the extinguisher is considered obsolete (see annex C).

5.1.4 Extinguishers having aluminum cylinders or shells suspected of being exposed to temperatures in excess of $160\text{ }^{\circ}\text{C}$ shall be removed from service and subjected to a hydrostatic test.

NOTE The structural integrity of aluminum cylinders or shells is reduced when they are exposed to temperatures in excess of $160\text{ }^{\circ}\text{C}$. These temperatures may occur under fire exposure or during repainting operations where oven drying is utilized.

5.2 Frequency

5.2.1 At intervals not exceeding 10 years, extinguishers shall be hydrostatically tested.

NOTE For non-rechargeable extinguishers, see 5.1.2.

5.2.2 High-pressure cartridges or nitrogen cylinders used for inert expellant gas storage for wheeled extinguishers shall be hydrostatically tested at intervals not exceeding 10 years.

EXCEPTION 1: Cartridges not exceeding 5 cm outside diameter and having a maximum capacity of 300 g are exempt from periodic hydrostatic retest.

EXCEPTION 2: Where national regulations specify shorter test intervals, those intervals shall apply.

5.2.3 A hydrostatic test shall be performed on extinguisher hose assemblies equipped with a shut-off nozzle at the end of the hose. The test interval shall be the same as specified for the extinguisher on which the hose is installed.

5.3 Test pressures

5.3.1 All extinguishers, cartridges and nitrogen cylinders used with wheeled extinguishers shall be tested at the factory test pressure.

5.3.2 Carbon dioxide hose assemblies shall be tested at 10 MPa (see 5.2.3).

5.3.3 Hose assemblies other than for carbon dioxide shall be tested at 2 MPa or at their service pressure, whichever is higher (see 5.2.3).

Annex A (normative)

Competent persons

A.1 General

This annex gives an approach to determining and assuring the competency of persons engaged in the servicing of fire extinguishers. Alternate methods may be considered in achieving a satisfactory level of competence.

A.2 Training and experience of a competent person

A.2.1 The competent person shall be trained with at least 3 months "on the job" or practical experience and by participation in a training course. The recommended length of the course should be at least 32 h. The competent person shall successfully pass an examination at the end of the training course. The examination shall be supervised by an independent body recognized by National Authorities.

A.2.2 The training course shall be run by a manufacturer or other qualified and recognized body.

A.2.3 The competent person shall attend a refresher course at least every 5 years.

Annex B (normative)

Proof-pressure testing

B.1 General

This annex gives a well-proven approach to proof-pressure testing of extinguisher pressure vessels. While the possibility of using equivalent procedures is not excluded, alternative methods should be considered carefully in the light of the inherent dangers.

B.2 Test equipment

B.2.1 Proof-pressure testing shall be performed hydrostatically.

WARNING: If air or gas is used as a sole medium for pressure testing, or if all air is not vented from the vessel prior to hydrostatic testing, failure of the extinguisher vessel will be violent and dangerous.

B.2.2 The equipment for testing high-pressure cylinders and cartridges shall be of the water jacket type that meets appropriate national specifications.

B.2.3 Hose assemblies of carbon dioxide extinguishers that require a hydrostatic test shall be tested within a protective cage device.

B.2.4 The equipment for testing low-pressure types consists of the following:

- a) a hydrostatic test pump, hand or power operated, to be capable of producing not less than 150 % of the test pressure; it shall include appropriate check valves and fittings;
- b) a flexible connection for attachment to the test pump. It shall be provided with necessary fittings to attach to the extinguisher closure;
- c) a protective cage or barrier for personnel protection, designed to provide visual observation of the extinguisher under test.

Figure B.1 illustrates a low-pressure, portable hydrostatic test cage designed to protect service personnel during such operations. It is used for hydrostatic tests of low-pressure extinguishers. It is not used for hydrostatic testing of high-pressure cylinders. The cage should not be anchored to the floor during test operations. Such cages can be made by any metal fabricator.

B.2.5 Drying equipment is required to dry all non-water types of extinguishers that have passed the hydrostatic test.

B.3 Test procedures

B.3.1 An internal examination shall be made prior to the hydrostatic test.

B.3.2 The hydrostatic testing of high-pressure cylinders and cartridges shall be in accordance with the procedures specified in the appropriate national standards for compressed gas cylinders.

B.3.3 The test procedures for low-pressure cylinders shall be as follows.

B.3.3.1 All valves, internal parts, and hose assemblies shall be removed and the extinguisher emptied.

EXCEPTION: On some powder extinguishers (cartridge-operated), the manufacturer may recommend that internal parts should not be removed.

B.3.3.2 All powder types of extinguishers shall have all traces of extinguishing materials removed from inside the shell before filling with water.

B.3.3.3 On all powder extinguishers having an externally mounted gas cartridge for creating discharge pressure, the cartridge (and some cartridge receivers) shall be removed and a suitable plug inserted into the shell opening at the point of removal.

B.3.3.4 All wheeled extinguishers equipped with a shut-off nozzle at the outlet end of the hose shall have the hose (complete with couplings but without the discharge nozzle) removed and tested separately.

To conduct maintenance or a hydrostatic test on wheeled extinguishers equipped with a regulator(s), disconnect the regulator or low-pressure hose from the media container.

B.3.3.5 On all wheeled stored pressure powder extinguishers, the head assembly shall be removed and replaced with a suitable test closure.

B.3.3.6 Then attach the hose of the hydrostatic test pump by the flexible connection to the discharge nozzle, hose assembly, test bonnet, or test fitting, as is applicable. In the case of wheeled powder extinguishers, procedures and fittings should be those recommended by the manufacturer.

B.3.3.7 Then place the extinguisher in the protective test cage or, in the case of wheeled units, place it behind a protective shield before applying the test pressure.

B.3.3.8 Then turn on the water supply to the test pump and fill the extinguisher to the top of its collar.

B.3.3.9 For extinguishers tested with their cap in place, the cap shall be tightened SLOWLY while the water supply remains open. When all of the entrapped air within the shell has been bled off and after water emerges, the cap shall be tightened fully.

B.3.3.10 For extinguishers tested with a test closure or fitting, the bonnet or fitting shall be tightened FULLY while the water supply remains open. When all of the entrapped air within the shell has been bled off and after water emerges, the vent shall be closed tightly.

B.3.3.11 Then apply pressure at a rate of pressure rise so the test pressure is reached in not less than 30 s. Maintain this test pressure for at least 30 s. Make observations during this time to note any distortion or leakage of the extinguisher shell.

B.3.3.12 If no distortion or leakage is noted and if the test pressure has not dropped, the pressure on the extinguisher shell may be released. The extinguisher is then considered to have passed the hydrostatic test.

B.3.3.13 All traces of water and moisture shall be removed from all powder and halon extinguishers by use of a cylinder dryer. If a heated air stream is used, the temperature within the shell shall not exceed 66 °C.

B.3.3.14 Any extinguisher shell that fails the hydrostatic test shall be destroyed by the owner or following his or her instructions.

B.3.4 The testing procedures for hose assemblies requiring a hydrostatic test shall be as follows.

B.3.4.1 The discharge nozzle shall be removed from the hose assembly without removal of any hose couplings.

B.3.4.2 For powder types, all traces of powder shall be removed.

B.3.4.3 Then place the hose assembly into a protective device, whose design will permit visual observation of the test. Personnel testing the hose assembly should remain a safe distance away from the hose being tested.

B.3.4.4 The hose shall be completely filled with water before testing.

B.3.4.5 Then apply pressure at a rate of pressure rise to reach the test pressure within 1 min. The test pressure shall be maintained for fully 1 min. Make observations to note any distortion or leakage.

B.3.4.6 If no distortion or leakage is noted, or the test pressure has not dropped, or the couplings have not moved, the pressure shall then be released. The hose assembly is then considered to have passed the hydrostatic test.

B.3.4.7 Hose assemblies passing the test shall then be completely dried internally. If heat is used for drying, the temperature shall not exceed 66 °C.

B.3.4.8 Hose assemblies failing a hydrostatic test shall be destroyed.

B.4 Recording of tests

B.4.1 High-pressure types

For high-pressure gas cylinders and cartridges passing a hydrostatic test, the month, year and the inspector's identification number shall be stamped onto the cylinder in accordance with the requirements of the appropriate national standard.

It is important that the recording (stamping) be placed only on the shoulder, top head, neck or footing (when so provided) of the cylinder.

B.4.2 Low-pressure types

Extinguisher shells that pass a hydrostatic test shall have the test information recorded on a durable label. The label shall be affixed to the shell by means of a heatless process. These labels shall be self-destructive when removal from an extinguisher shell is attempted. The label shall include the following information:

- month and year the test was performed;
- test pressure used;
- name or initials of person performing the test, or name of agency performing the test.

Hose assemblies passing a hydrostatic test are not required to be recorded.

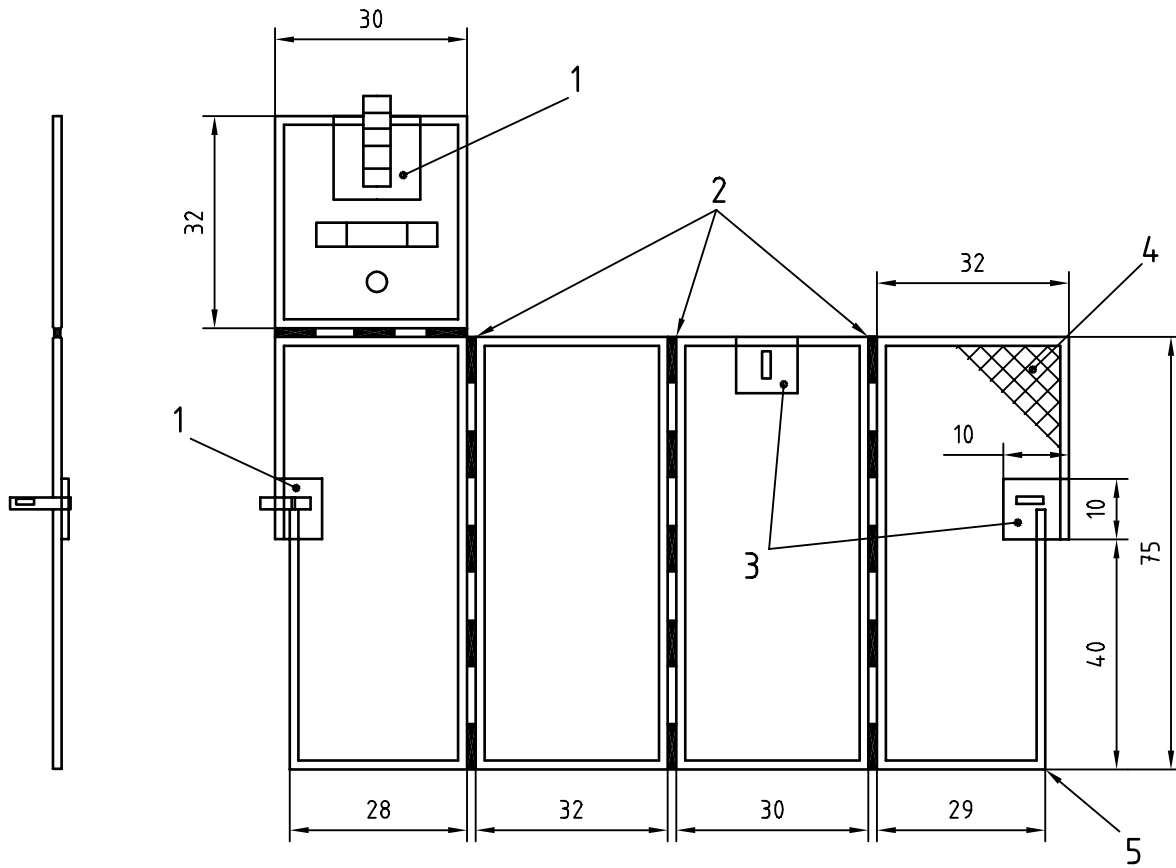

a) Details of cage

Key

- 1 Hasp on 10 cm x 7,5 cm plate
- 2 Piano hinges
- 3 Latches
- 4 Flattened, expanded metal, 1,5 cm thick, of gauge 16-18
- 5 1,5 cm strip on all edges
- 6 Hasp and latch
- 7 Handle
- 8 Hose opening

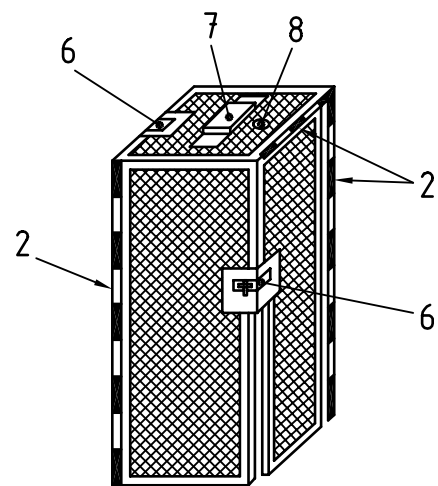

b) Overall view

Figure B.1 — Example of a low-pressure portable hydrostatic test cage

Annex C (normative)

Obsolete extinguishers

The following types of extinguishers are considered obsolete and shall be removed from service:

- a) soda acid types;
- b) chemical foam types;
- c) chlorobromomethane or carbon tetrachloride types;
- d) non-rechargeable types more than 5 years old;
- e) inverting types;
- f) copper or brass shell types (excluding pump tanks) jointed by softer solder or rivets;
- g) steel shell types jointed by rivets;
- h) other extinguisher types regulated as unsuitable or unsafe for use by National Authorities.

Annex D (informative)

Hazard types

Table D.1 is an example of specific criteria for selection of the hazard type (see ISO 11602-1 for definitions).

Table D.1

Parameter	Type of hazard		
	Low	Moderate	High
Height of building (m)	up to 25	not applicable	in excess of 25
Number of occupants	less than 15	between 15 and 250	in excess of 250
Building surface area (m ²)	less than 300	between 300 and 3 000	in excess of 3 000
Flammable gases (litre)	less than 500	between 500 and 3 000	in excess of 3 000
Flammable liquids (litre)	less than 250	between 250 and 1 000	in excess of 1 000
Combustible liquids (litre)	less than 500	between 1 000 and 2 000	in excess of 2 000

ICS 13.220.10

Price based on 16 pages

© ISO 2000 – All rights reserved