

---

---

**Gas cylinders — Refillable welded steel cylinders containing materials for sub-atmospheric gas packaging (excluding acetylene) — Design, construction, testing, use and periodic inspection**

*Bouteilles à gaz — Bouteilles en acier soudées rechargeables contenant des matériaux pour le stockage des gaz à une pression sub-atmosphérique (à l'exclusion de l'acétylène) — Conception, fabrication, essais, utilisation et contrôle périodique*





**COPYRIGHT PROTECTED DOCUMENT**

© ISO 2011

All rights reserved. Unless otherwise specified, no part of this publication may be reproduced or utilized in any form or by any means, electronic or mechanical, including photocopying and microfilm, without permission in writing from either ISO at the address below or ISO's member body in the country of the requester.

ISO copyright office  
Case postale 56 • CH-1211 Geneva 20  
Tel. + 41 22 749 01 11  
Fax + 41 22 749 09 47  
E-mail [copyright@iso.org](mailto:copyright@iso.org)  
Web [www.iso.org](http://www.iso.org)

Published in Switzerland

# Contents

Page

Foreword .....	v
Introduction .....	vi
1 Scope .....	1
2 Normative references .....	1
3 Terms, definitions and symbols .....	2
3.1 Terms and definitions .....	2
3.2 Symbols .....	2
4 Inspection and testing .....	3
5 Materials and stress relieving .....	3
6 Design .....	4
6.1 General .....	4
6.2 Calculation of cylindrical wall thickness .....	5
6.3 Design of cylinder ends .....	5
6.4 Minimum wall thickness .....	6
6.5 Pressure relief device .....	7
7 Construction and workmanship .....	7
7.1 General .....	7
7.2 Welding qualification .....	8
7.3 Welding seams of pressure containing parts .....	8
7.4 Valve protection .....	8
7.5 Boss threads .....	8
7.6 Visual examination .....	8
8 Technical requirements for type approval testing (new design tests) .....	11
8.1 General .....	11
8.2 Verifications and tests .....	11
8.3 Description of verification tests .....	12
9 Batch tests .....	13
9.1 General .....	13
9.2 Information .....	13
9.3 Checks and verifications .....	13
9.4 Tensile test .....	14
9.5 Bend test .....	15
9.6 Macroscopic examination of weld cross-sections .....	16
9.7 Radiographic examination of welds .....	16
10 Tests on every cylinder .....	16
11 Failure to meet verification and test requirements .....	17
12 Marking .....	17
13 Certification .....	17
Annex A (normative) Inspection at time of fill .....	18
Annex B (normative) Periodic inspection and test .....	20
Annex C (informative) Gases currently being transported .....	21
Bibliography .....	23

## Foreword

ISO (the International Organization for Standardization) is a worldwide federation of national standards bodies (ISO member bodies). The work of preparing International Standards is normally carried out through ISO technical committees. Each member body interested in a subject for which a technical committee has been established has the right to be represented on that committee. International organizations, governmental and non-governmental, in liaison with ISO, also take part in the work. ISO collaborates closely with the International Electrotechnical Commission (IEC) on all matters of electrotechnical standardization.

International Standards are drafted in accordance with the rules given in the ISO/IEC Directives, Part 2.

The main task of technical committees is to prepare International Standards. Draft International Standards adopted by the technical committees are circulated to the member bodies for voting. Publication as an International Standard requires approval by at least 75 % of the member bodies casting a vote.

Attention is drawn to the possibility that some of the elements of this document may be the subject of patent rights. ISO shall not be held responsible for identifying any or all such patent rights.

ISO 11513 was prepared by Technical Committee ISO/TC 58, *Gas cylinders*, Subcommittee SC 3, *Cylinder design*.

## Introduction

This International Standard provides a specification for the design, manufacture, use and periodic inspection and testing of a welded steel cylinder necessary to facilitate sub-atmospheric pressure gas packaging technology on a worldwide basis. The specifications given are based on knowledge of, and experience with, materials, design requirements, manufacturing processes and control at manufacture of cylinders in common use in the countries of the ISO member bodies. With respect to those aspects concerning construction materials, approval of design rules and inspection during manufacture which are subject to national or international regulations, it is necessary for interested parties to ensure that, in the practical application of this International Standard, the requirements of the relevant authority are also satisfied.

The pressure shell of the cylinder is fabricated by manufacturing a cylindrical shape with a base and welding a machined plug (boss) or semi-ellipsoidal or torispherical shape onto the open end of the shell to form the cylinder. This method of fabrication allows for insertion of material prior to sealing the cylinder.

A further objective of this International Standard is to balance design and economic efficiency against international acceptance and universal utility. It aims to eliminate the concerns about climate, duplicate inspections and restrictions currently existing because of lack of definitive International Standards. It should not be construed as reflecting on the suitability of the practices of any nation or region.



# Gas cylinders — Refillable welded steel cylinders containing materials for sub-atmospheric gas packaging (excluding acetylene) — Design, construction, testing, use and periodic inspection

**WARNING** — This International Standard requires the use of substances and procedures that may be injurious to health if adequate precautions are not taken. It refers only to technical suitability and does not absolve the user from legal obligations relating to health and safety at any stage. It has been assumed in the drafting of this International Standard that the execution of its provisions is entrusted to appropriately qualified and experienced people.

## 1 Scope

This International Standard specifies minimum requirements for the material, design, construction, workmanship, examination and testing at manufacture of refillable welded steel cylinders for the sub-atmospheric pressure storage of liquefied and compressed gases. It only applies to the cylinders themselves, irrespective of the materials contained therein (e.g. adsorbents, media, materials and/or gases) and other related applications. The cylinders have a test pressure not greater than 42 bar and a water capacity from 0,5 l up to and including 12 l exposed to ambient temperatures for the purpose of facilitating the sub-atmospheric pressure storage of liquefied and compressed gases. Inspection at the time of fill is specified in Annex A and periodic inspection and testing is specified in Annex B.

High-pressure and low-pressure liquefied gases as specified in Annex C can be suitably filled into these cylinders. The filling pressure will be less than one bar gauge at 21 °C.

## 2 Normative references

The following referenced documents are indispensable for the application of this document. For dated references, only the edition cited applies. For undated references, the latest edition of the referenced document (including any amendments) applies.

ISO 2504:1973, *Radiography of welds and viewing conditions for films — Utilization of the recommended patterns of image quality indications (I.Q.I.)*

ISO 4978, *Flat rolled steel products for welded gas cylinders*

ISO 6892-1:2009, *Metallic materials — Tensile testing — Part 1: Method of test at room temperature*

ISO 7438, *Metallic materials — Bend test*

ISO 9809-3:2010, *Gas cylinders — Refillable seamless steel gas cylinders — Design, construction and testing — Part 3: Normalised steel cylinders*

ISO 11117, *Gas cylinders — Valve protection caps and valve guards — Design, construction and tests*

ISO 13769, *Gas cylinders — Stamp marking*

ISO 15614-1, *Specification and qualification of welding procedures for metallic materials — Welding procedure test — Part 1: Arc and gas welding of steels and arc welding of nickel and nickel alloys*

ISO 17637, *Non-destructive testing of welds — Visual testing of fusion-welded joints*

ISO 17639, *Destructive tests on welds in metallic materials — Macroscopic and microscopic examination of welds*

UN Recommendations on the Transport of Dangerous Goods — Model Regulations, sixteenth edition, Packaging Note P200

### 3 Terms, definitions and symbols

For the purposes of this document, the following terms and definitions apply.

#### 3.1 Terms and definitions

##### 3.1.1

##### yield strength

value corresponding to the lower yield strength,  $R_{eL}$ , or  $0,92 \times$  the upper yield strength,  $R_{eH}$ , or for steels that do not exhibit a defined yield, the 0,2 % proof strength,  $R_{p0,2}$

##### 3.1.2

##### stress relieving

heat treatment given to the drawn pressure shell by heating to a uniform temperature below the lower critical point,  $AC_1$ , of the steel and cooling in a still atmosphere

NOTE The object is to reduce the residual stresses without altering the metallurgical structure of the steel.

##### 3.1.3

##### batch

quantity of finished cylinders made consecutively during the same or consecutive days to the same design, size and material specifications and cast for each pressure-containing part on the same equipment and subjected to the same heat-treatment conditions

NOTE Different suppliers can be used for the different pressure-containing parts within a batch, e.g. one supplier for shells, another for plugs.

##### 3.1.4

##### design stress factor

$F$   
ratio of equivalent wall stress at test pressure,  $p_H$ , to guaranteed minimum yield strength,  $R_{eg}$

##### 3.1.5

##### sub-atmospheric gas packaging

gas source package that stores and delivers gas at sub-atmospheric pressure, which includes a container (e.g. gas cylinder and outlet valve) that stores and delivers gas at a pressure of less than 1 bar at normal conditions of temperature and pressure

NOTE The container can incorporate a medium in order to reduce the pressure of the gas to sub-atmospheric levels.

#### 3.2 Symbols

- $a$  Calculated minimum thickness, in millimetres, of the cylindrical shell
- $a'$  Guaranteed minimum thickness, in millimetres, of the cylindrical shell (including any corrosion allowance, see 8.1)
- $a_1$  Guaranteed minimum thickness, in millimeters, of a concave base at the knuckle. See Figure 1 a).
- $a_2$  Guaranteed minimum thickness, in millimetres, at the centre of a concave base. See Figure 1 a).
- $b$  Calculated minimum thickness, in millimetres, of the cylinder end
- $A$  Percentage elongation after fracture
- $D$  Outside diameter of the cylinder, in millimetres



$d$	Internal diameter of the cylinder, in millimetres
$F$	Design stress factor
$h$	Outside height, in millimetres, of domed part (convex base end). See Figure 1 a).
$L$	Length of the cylinder, in millimetres
$P_b$	Measured burst pressure, in bars, above atmospheric pressure, in the burst test
$p_h$	Test pressure above atmospheric pressure, in bars
$P_y$	The observed pressure when cylinder starts yielding during hydraulic bursting tests, in bars, above atmospheric pressure
$r$	Inside knuckle radius, in millimetres. See Figures 1 and 2.
$R_{eg}$	Guaranteed minimum yield strength in megapascals (yield strength as defined in 3.1.1), for the finished cylinder and used for design calculation
$R_{ea}$	Value of the actual yield strength in megapascals (yield strength as defined in 3.1.1), determined by the tensile test. See 9.4.2.2.
$R_{ma}$	Value of the actual tensile strength in megapascals as determined by the tensile test. See 9.4.2.2.
$R_{mg}$	Guaranteed minimum tensile strength in megapascals, for the finished cylinder and used for design calculations

## 4 Inspection and testing

Evaluation of conformity shall be performed in accordance with the relevant regulations of the country or countries where the cylinders are used.

To ensure that the cylinders conform to this International Standard, they should be subject to inspection and testing by an authorized inspection body recognized in the country or countries of manufacture.

Equipment used for measurement, testing and examination during production shall be maintained and calibrated within a documented quality management system.

## 5 Materials and stress relieving

**5.1** Materials for shells and end pressings shall conform to either ISO 4978 or ISO 9809-3.

NOTE "Materials" refers to materials in the state before transformation with regard to the manufacturing process.

To conform to the state of the art for modern steel manufacturing and steel grades used for pressure purposes, the same limits on sulphur and phosphorous contents as noted in 5.9.1 of ISO 4706:2008 for refillable welded steel cylinders and Table 3 of ISO 9809-3:2010 shall apply in this International Standard. The following limits are noted:

- carbon: 0,25 % max.;
- silicon: 0,45 % max.;
- manganese: 1,60 % max.;
- phosphorous: 0,040 % max.;
- sulphur: 0,040 % max.

**5.2** All parts welded to the cylinder shall be made of compatible materials with respect to their weldability.

**5.3** The welding consumables selected by the manufacturer shall be compatible with the base materials and shall produce welds which meet the minimum strength values used in the design of the cylinder and guaranteed by the manufacturer of the finished cylinder.

**5.4** The cylinder manufacturer shall have certificates of the ladle analysis and mechanical properties of the steel supplied for the construction of the pressure-retaining parts of the cylinder.

**5.5** The manufacturer shall maintain a system of identification for the materials used in fabrication so that all materials for pressure parts in the completed cylinder are traceable to their origin.

**5.6** Grades of steel used for cylinder manufacture shall be compatible with the intended gas service, e.g. corrosive gases, embrittling gases. See ISO 11114-1.

**5.7** The drawn pressure shell and plug shall be delivered in the stress-relieved condition. Localized stress relief of the drawn pressure shell and plug shall not be undertaken.

The quality of the welds shall be checked by non-destructive examination (NDE) or other equivalent means to demonstrate that the cylinder is fit for the intended service. See 9.7.4.

The actual temperature of stress relief to which a type of steel is subjected for a given tensile strength shall not deviate by more than 30 °C from the temperature specified by the manufacturer for the cylinder type.

**5.8** The material properties of the finished cylinders shall be suitable to meet the requirements of Clause 8 and Clause 9.

Only steel pressure receptacles resistant to hydrogen embrittlement can be used for gases assigned the special packing provision "d" as per Table 2 of P200 of the UN Model Regulations. See Annex C.

## 6 Design

### 6.1 General

**6.1.1** The calculation of the wall thickness of the pressure-containing parts shall be related to the guaranteed minimum yield strength,  $R_{eg}$ , for the parent material in the finished cylinder.

For certain gases, additional corrosion allowances may be applicable.

**6.1.2** For calculation purposes, the value of the yield strength,  $R_{eg}$ , shall be limited to a maximum of 0,85  $R_{mg}$ .

**6.1.3** The internal pressure upon which the minimum sidewall thickness calculation of gas cylinders is based shall be the test pressure,  $p_h$ .

**6.1.4** A fully dimensioned drawing including the specification of the material shall be produced.

## 6.2 Calculation of cylindrical wall thickness

The guaranteed minimum thickness of the cylindrical shell shall be not less than that calculated using the following formula:

$$a = \frac{D}{2} \times \left( 1 - \sqrt{\frac{10 \times F \times R_{eg} - \sqrt{3} \times p_h}{10 \times F \times R_{eg}}} \right)$$

where  $F$  is the lesser of  $\frac{0,65}{R_{eg}}$  or 0,77.

$\frac{R_{eg}}{R_{mg}}$  shall not exceed 0,85.

The guaranteed minimum thickness of the cylinder shell shall also conform to 6.4.

## 6.3 Design of cylinder ends

NOTE Examples of typical cylinder ends are shown in Figure 1. Figure 1 a) is a typical base end concave to pressure and Figure 1 b) is a typical end plug used to seal the top of the cylinder.

### 6.3.1 General

The thickness in the base of a cylinder with a convex base end shall not be less than the guaranteed minimum wall thickness of the cylindrical shell specified in 6.2.

### 6.3.2 Design of base concave to pressure

When concave base ends [see Figure 1 a)] are used, the following design values are recommended:

$$a_1 \geq 2a$$

$$a_2 \geq 2a$$

$$h \geq 0,12 D$$

$$r \geq 0,075 D$$

The design drawing shall at least show values for  $a_1$ ,  $a_2$ ,  $h$  and  $r$ .

The cylinder manufacturer shall in all cases prove by the pressure cycling test given in 8.3.2 that the design is satisfactory.

NOTE 1 An example of a typical end is shown in Figure 1 a).

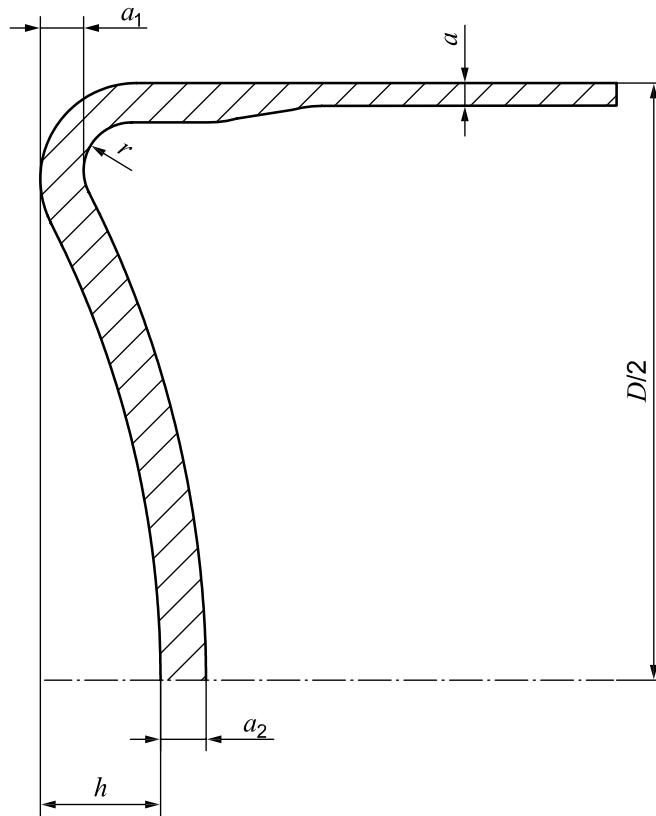

a) Illustration of cylinder base end concave to pressure

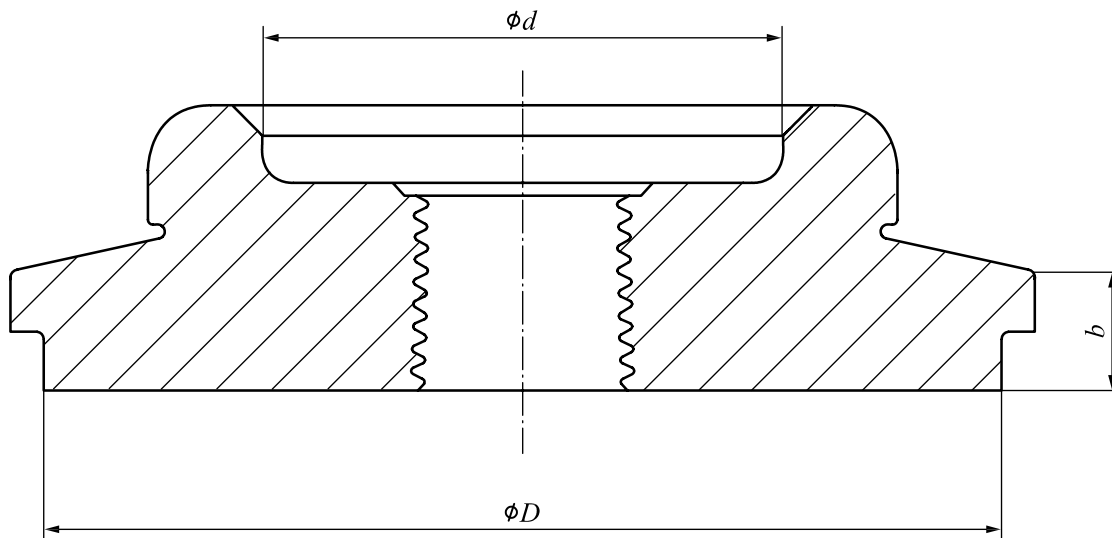

b) Boss style end plug with inlet threads

Figure 1 — Typical cylinder ends

## 6.4 Minimum wall thickness

6.4.1 The minimum wall thickness of the cylindrical shell including the base,  $a$ , shall be not less than the value derived from the appropriate formula listed hereafter:

for  $D \leq 100$  mm,  $a = 1,1$  mm;

for  $100 \text{ mm} < D \leq 150 \text{ mm}$ ,  $a = 1,1 + 0,008(D-100) \text{ mm}$ ;

for  $D > 150 \text{ mm}$ ,  $a = \frac{D}{250} + 0,7 \text{ mm}$ , with an absolute minimum of 1,5 mm.

**6.4.2** The minimum thickness,  $b$ , of end plugs (bosses) used to seal the top of the cylinder shall be at least twice the thickness of the cylinder sidewall,  $a$ , i.e.  $b \geq 2a$ .

The adequacy of the end plug design shall be demonstrated by the pressure cycling test in accordance with 8.3.2.

NOTE An example of a typical end plug to seal the top of the cylinder is shown in Figure 2.

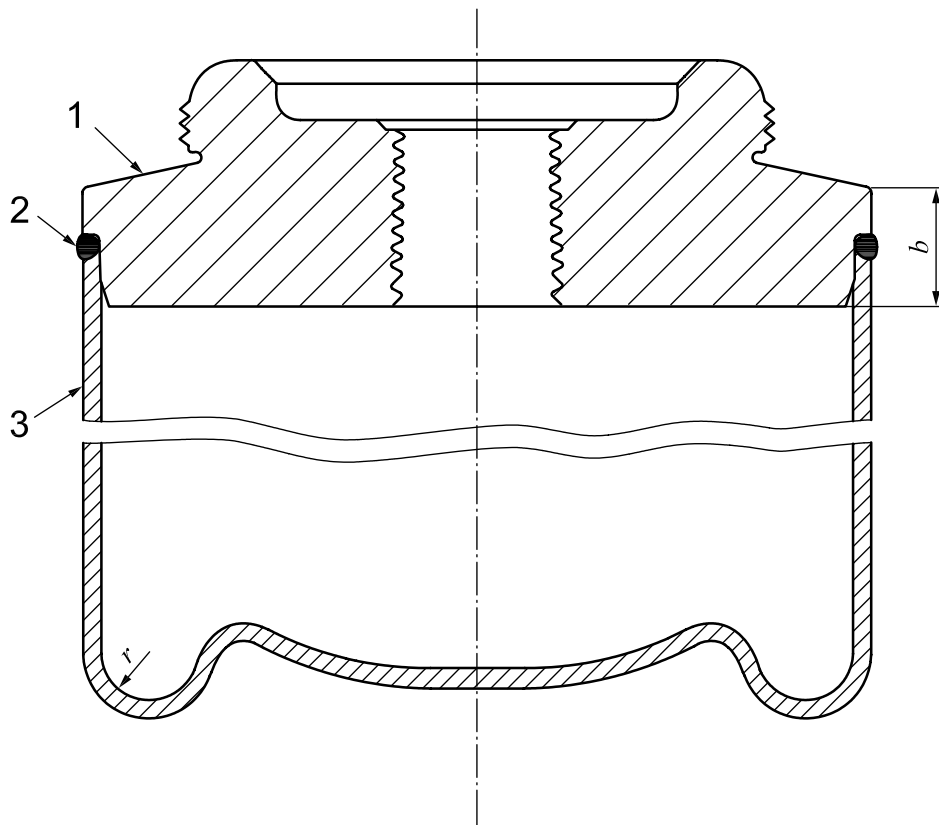

#### Key

- 1 end plug (boss)
- 2 butt weld
- 3 cylinder shell
- $r$  knuckle radius

**Figure 2 — Example of boss style end plug welded to cylinder shell**

## 6.5 Pressure relief device

No pressure relief devices shall be included in the design.

## 7 Construction and workmanship

### 7.1 General

The containers in question are composed of a seamless shell with a boss welded to the open end.

The cylinder shall be produced by

- a) forging or drop forging from a solid ingot or billet, or
- b) pressing from a flat plate.

## **7.2 Welding qualification**

Welding procedures shall be in accordance with ISO 15614-1. It is advisable that welders conform to ISO 9606-1 and welding operators to ISO 14732 for all welding associated with the pressure envelope, including the non-pressure containing parts.

Welds made in production shall be representative of those generated from the welding procedure approval tests.

## **7.3 Welding seams of pressure containing parts**

The circumferential seam shall be butt welded as illustrated in Figure 2.

## **7.4 Valve protection**

**7.4.1** Valves shall be protected from damage, which could cause release of gas, either by the design of the cylinder (e.g. protective shroud) or by a valve protection device in accordance with ISO 11117.

**7.4.2** When a protective shroud is used, it shall fulfil the requirements of the drop test described in ISO 11117.

## **7.5 Boss threads**

The internal neck threads shall conform to a recognized standard to permit the use of a corresponding valve thus minimizing neck stresses following the valve torquing operation. Internal neck threads shall be checked using gauges corresponding to the agreed neck threads or by an alternate method of equivalent sensitivity. Particular care shall be taken to ensure that the neck threads are accurately cut from full form and are free from any sharp profiles or burrs.

The internal thread shall be tapered and conform to a recognized standard for tapered threads, such as ISO 11116-1.

When required, the external thread shall conform to a recognized standard.

**NOTE** For example, where the neck thread is specified as being in accordance with ISO 11116-1, the corresponding gauges are specified in ISO 11116-2.

## **7.6 Visual examination**

### **7.6.1 Imperfections**

Before assembly, the pressure containing parts of the cylinders shall be examined for uniform quality and freedom from imperfections which may ultimately affect the cylinder integrity.

### **7.6.2 Welds**

**7.6.2.1** The welding of the circumferential joint (pressure envelope) shall be performed by a fully mechanized, semi-automatic or automatic process to provide consistent and reproducible weld quality.

**7.6.2.2** The fusion of the welded metal with the parent metal (pressure joint) for circumferential seams and bosses shall be smooth, have a finish without concavity and that is free from lack of fusion, undercutting or abrupt irregularity.

**7.6.2.3** Inspection of welds shall be performed in accordance with ISO 17637.

**7.6.2.4** Circumferential joints, of which there shall be no more than one, shall be butt welded or joggled welded. See Figure 3.

**7.6.2.5** Welds shall have full penetration. This shall be verified by using ISO 17639. The excess thickness shall be such that the weld integrity is not compromised. Macro etching and etch tests are authorized in ISO 17639.

**7.6.2.6** Vee butt welds shall have weld penetration verified by bend testing and tensile testing. If sufficient material is not available for these tests due to the cylinder geometry, the integrity of the weld shall be verified by macro-etching as specified in ISO 17639. The pass/fail criteria for the macro-etch test is in accordance with ISO 17639.

**7.6.2.7** Radiographic examination, radiosopic examination, or NDE carried out using another suitable method shall be as specified in 9.7.

**7.6.2.8** Non-pressure containing attachments shall not be welded to the cylinder.

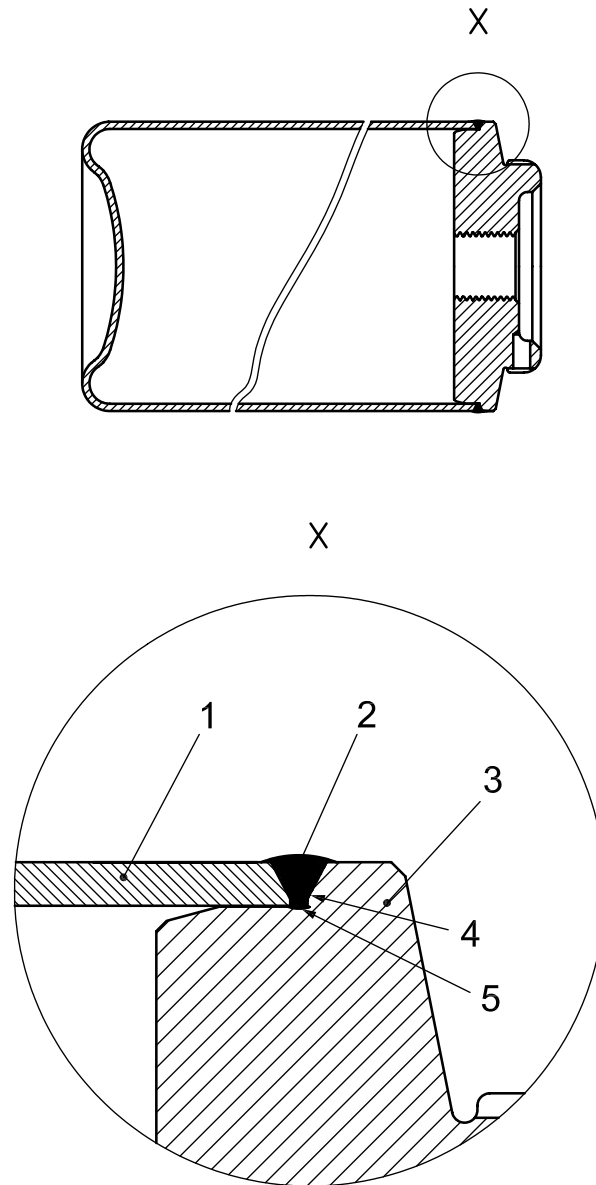

**Key**

- 1 cylinder shell
- 2 weld
- 3 end plug
- 4 land
- 5 root

**Figure 3 — Weld penetration**

**7.6.3 Out-of-roundness**

The out-of-roundness of the cylindrical part of the shell shall be limited so that the difference between the maximum and the minimum outside diameter in the same cross-section is not more than 2 % of the mean of these diameters.

**7.6.4 Straightness**

Unless otherwise specified on the manufacturing drawing, the maximum deviation of the cylindrical part of the shell from a straight line shall not exceed 0,3 % of the cylindrical length.



### 7.6.5 Verticality

When the cylinder is standing on its base, the cylindrical shell and concentric top opening shall be vertical to within 1 % of the cylindrical length.

## 8 Technical requirements for type approval testing (new design tests)

### 8.1 General

**8.1.1** A technical specification of each new design of cylinder, or cylinder family as specified in g), including design drawing, design calculations, steel details, manufacturing process and heat treatment details, shall be submitted by the manufacturer to the inspector. The type approval tests detailed in 8.2 shall be carried out on each new design under the supervision of the inspector.

A cylinder shall be considered to be of a new design, compared with an existing design, when at least one of the following applies:

- a) it is manufactured in a different factory;
- b) it is manufactured by a different welding process or a change in an existing process, e.g. change of type of heat treatment;
- c) it is manufactured from a steel of different specified chemical composition range, as stated in ISO 9809-3:2010, 6.2;
- d) it is given a heat treatment outside the ranges specified in 5.7;
- e) there is a change in base profile, e.g. concave, convex, hemispherical, or there is a change in the base thickness/cylinder diameter ratio;
- f) the guaranteed minimum yield strength,  $R_{eg}$ , or guaranteed minimum tensile strength,  $R_{mg}$ , has changed;
- g) the overall length of the cylinder has increased by more than 50 % (cylinders with a length/diameter ratio of less than 3 shall not be used as reference cylinders for any new design with this ratio greater than 3);
- h) the nominal outside diameter has changed;
- i) the guaranteed minimum wall thickness,  $a'$ , has been decreased;
- j) the hydraulic test pressure has been changed (where a cylinder is used for a lower pressure duty than that for which the cylinder was approved, it shall not be deemed a new design).

**8.1.2** A minimum of 50 finished cylinders, representative of a new design, shall be made available for type approval testing. The minimum wall thickness of the test cylinders shall not exceed 15 % of the minimum guaranteed wall thickness for type approval design. For type approval testing requirements, select cylinders from the batch having the thinnest walls. If the total production is less than 50 cylinders, a sufficient number of cylinders shall be made to complete the tests required, in addition to the production quantity. In this case, the type approval certificate shall be limited to the particular batch.

**8.1.3** The type approval process shall include the verifications and tests specified in 8.2.

### 8.2 Verifications and tests

In the course of the type approval process, the inspector shall select the necessary cylinders for testing and

- a) verify that
  - 1) the requirements of Clause 5 (material) are met,
  - 2) the design conforms to the requirements of Clause 6 (design),

- 3) the requirements of Clause 7 (construction and workmanship) are met for all cylinders selected,
  - 4) internal and external surfaces of the cylinders are free of any imperfection which may make them unsafe for use (examples of defects for the drawn shell and base are given in ISO 9809-3:2010, Table A.1);
- b) witness the following tests on the cylinders selected after the welds of the cylinders have been visually inspected; cylinders selected for burst and pressure cycle testing are not required to contain material:
- 1) the test specified in 8.3.1 (hydraulic burst test) on three cylinders, the cylinder bearing representative stamp marking;
  - 2) the test specified in 8.3.2 (pressure cycling test) on three cylinders, the cylinder bearing representative stamp marking;
  - 3) the tests specified in 9.4 (tensile test), 9.5 (bend test), and 9.6 (macroscopic examination of weld cross-sections), on one cylinder, the test pieces being identifiable to the batch;
  - 4) tests specified in Clause 10 (pneumatic pressure test);
  - 5) radiographic examination, radiosopic examination, or NDE carried out using another suitable method, as specified in 9.7, on cylinders randomly selected from the batch;
  - 6) the geometrical requirements for the tapered threaded valve connection are complied with for all cylinders selected by the inspector.

### 8.3 Description of verification tests

#### 8.3.1 Hydraulic burst test

**8.3.1.1** Cylinders subjected to this test shall bear markings in accordance with the complete stamp markings as required for the finished cylinder. The hydraulic burst test shall be carried out with equipment which enables the pressure to be increased at a controlled rate until the cylinder bursts and allows the change in pressure with time to be recorded.

**8.3.1.2** The burst pressure,  $p_b$ , of the cylinder shall not be less than 94,5 bar.

**8.3.1.3** The cylinder shall remain in one piece and shall not fragment.

**8.3.1.4** The main fracture shall not show any brittleness, i.e. the edges of the fracture shall not be radial but shall be at an angle to a diametrical plane and display a reduction of area throughout their thickness. The fracture shall be examined and shall be free of defects, e.g. lamination. Initiation and/or any fracture of the cylinder shall not occur at the markings or in a weld, including the heat-affected zones.

**8.3.1.5** The ratio of the volumetric expansion of the cylinder to its initial volume shall be a minimum of 20 %. In addition, a separate requirement for the minimum yield pressure ( $P_y > P_H/F$ ) can be added.

#### 8.3.2 Pressure cycling test

**8.3.2.1** The pressure cycling test shall be carried out on three cylinders bearing stamp markings generated by the production process. The inspector shall select cylinders from the batch having the thinnest walls for the pressure cycling test.

**8.3.2.2** The tests shall be carried out with a non-corrosive liquid, subjecting the cylinder to successive reversals at an upper cyclic pressure which is equal to the hydraulic test pressure,  $p_h$ . The value of the lower cyclic pressure shall not exceed 10 % of the upper cyclic pressure. The frequency of reversals of pressure shall not exceed 0,25 Hz (15 cycles/min). The temperature measured on the outside surface of the cylinder shall not exceed 50 °C during the test.

**8.3.2.3** The cylinder shall be subjected to 12 000 cycles without leakage or failure.

**8.3.2.4** On completion of pressure cycling, two cylinders shall be burst tested in accordance with 8.3.1. The results of two cylinders undergoing the burst test shall be in accordance with 8.3.1.2, 8.3.1.3, 8.3.1.4 and 8.3.1.5.

The remaining cylinder shall be sectioned to check for evidence of fatigue cracking and verification of minimum wall thickness.

## 9 Batch tests

### 9.1 General

For the purpose of carrying out batch testing, a random sample of cylinders, as given in Table 1, shall be taken from each batch, as defined in 3.1.3. A batch shall consist of a maximum of 200 cylinders, excluding test specimens. All batch tests shall be carried out on finished cylinders.

**Table 1 — Batch sampling**

Batch size	Number of cylinders taken as samples	Number of cylinders to be tested		
		Tensile test and bend test (as per 9.4 and 9.5)	Macroscopic examination (as per 9.6)	Burst test (as per 8.3.1)
Up to 200 (excluding test specimens)	3	1	1 (same cylinder as used in tensile and bend test)	2

### 9.2 Information

For the purposes of batch testing, the manufacturer shall provide the following:

- the type approval certificate;
- the certificates for the construction material, as required in 5.4, stating the cast analyses of the steel supplied for the construction of the cylinders;
- a list of cylinders, stating serial numbers and stamp markings as required;
- a statement of the thread checking method used and the results thereof.

### 9.3 Checks and verifications

The following checks and verifications shall be carried out on each batch of cylinders by the inspector.

- Ascertain that a type approval certificate has been obtained and that the cylinders conform to it.
- Check whether the requirements specified in Clauses 5, 6, 7 and 12 have been met and, in particular, check by an external and internal examination of the cylinders whether the construction and checks carried out by the manufacturer in accordance with Clause 6 are satisfactory. The visual examination shall cover at least 10 % of the cylinders submitted. However, if an unacceptable imperfection is found (as described in ISO 9809-3:2010, Table A.1), 100 % of cylinders shall be visually inspected.
- Carry out or witness the tests specified in 9.4 (tensile test), 9.5 (bend test), 9.6 (macroscopic examination of weld cross-sections) and 8.3.1 (hydraulic burst test) on the number of cylinders specified in 9.1.
- Carry out or witness the tests specified in Clause 10 (pneumatic pressure test).

- Check whether the information supplied by the manufacturer specified in 9.2 is correct; random checks shall be carried out.
- Assess the results of the NDE, as specified in 9.7.

## 9.4 Tensile test

### 9.4.1 General

The tensile test on parent metal shall be carried out on a test sample taken from the finished cylinder in accordance with ISO 6892-1.

The two faces of the test sample formed by the inside and the outside surfaces of the cylinder shall not be machined. The tensile test on welds shall be carried out in accordance with 9.4.3.

Cylinders selected for tensile testing shall be empty.

### 9.4.2 Tensile test samples required from parent material

**9.4.2.1** One tensile test sample shall be cut in the longitudinal direction from the cylindrical portion of the cylinder.

**9.4.2.2** The values obtained for the actual yield strength,  $R_{ea}$ , actual tensile strength,  $R_{ma}$ , and elongation after fracture,  $A$ , shall be not less than those guaranteed by the cylinder manufacturer for the finished cylinder.

### 9.4.3 Tensile test samples required from welds

**9.4.3.1** One tensile test sample shall be taken and prepared as follows.

- The inspector shall select a shell.
- The tensile test perpendicular to the weld (see ISO 4136) shall be carried out on a test specimen having a reduced cross-section of 25 mm in width for a length extending up to 15 mm beyond the edges of the weld (see Figure 4). Beyond this central part, the width of the test specimen shall increase progressively.
- For a boss style end, weld an extended boss (to allow the extraction of a standard tensile test piece from the welded cylinder) to the open end of the selected shell using the same procedures and equipment as for welding the boss. The extended boss shall be made from the same material and shall have the same weld joint configuration as the boss (see Figure 5).

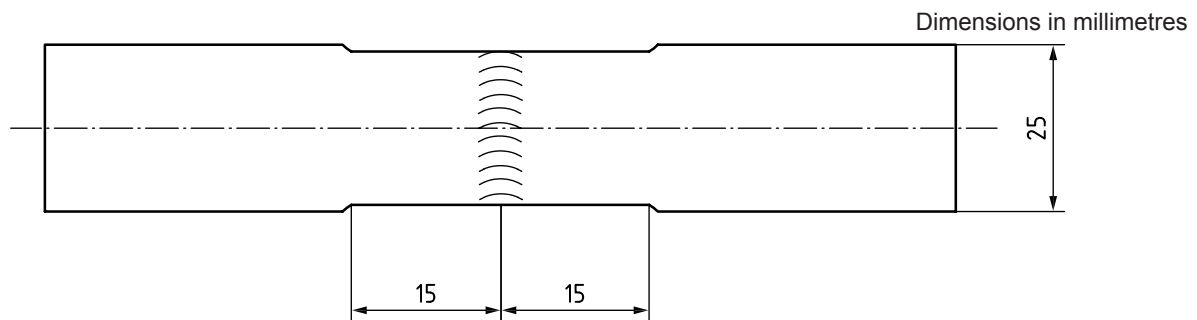
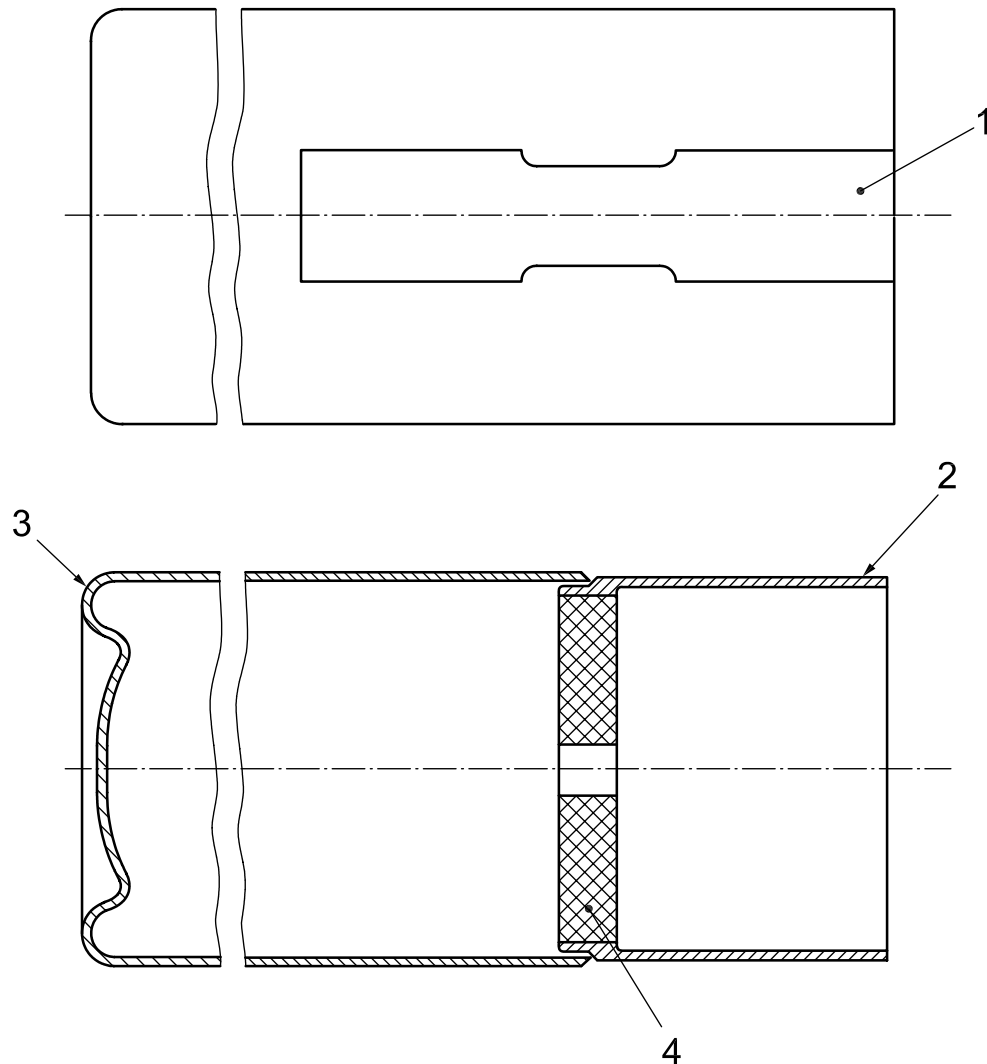

Figure 4 — Test specimen for tensile test perpendicular to the weld



### Key

- 1 weld tensile coupon
- 2 extended boss
- 3 cylinder shell
- 4 area of extended boss to be removed after welding

**Figure 5 — An example of the extended boss inserted into the cylinder shell alongside a drawing that shows how the coupon is cut from the shell/extended boss assembly**

**9.4.3.2** All tensile tests shall be in a direction transverse to the weld. The face and root of the weld in the test sample shall be machined flush with the plate surface.

The face and back of the parent metal shall not be machined but shall represent the surface of the cylinder as manufactured. The ends only may be flattened, by cold pressing, for gripping in the test machine. The tensile strength value obtained shall be at least equal to the minimum value specified in 9.4.2.2 for the parent metal, regardless of the position of the fracture.

## 9.5 Bend test

**9.5.1** The bend test shall be carried out in accordance with ISO 7438. The bend test specimen shall be 25 mm in width. The mandrel shall be placed in the centre of the weld while the test is being performed and remain in that position until the conclusion of the test.

**9.5.2** Cracks shall not appear in the test specimen when it is bent around a mandrel through 180°.

## **9.6 Macroscopic examination of weld cross-sections**

The macroscopic examination, carried out in accordance with ISO 17639, of a full transverse section of the welds, shall show complete fusion and complete penetration as specified in 9.7.3. In case of doubt, a microscopic examination of the suspect area shall be made.

## **9.7 Radiographic examination of welds**

**9.7.1** The radiographic examination may be replaced by radioscopy or another suitable non-destructive testing (NDT) method if the applied method is carried out in accordance with a process that provides the same level of quality of examination as radiographic examination. Radiographic examination shall conform to the techniques specified in 9.7.2 and 9.7.3.

**9.7.2** Assessment of the weld radiographs shall be based on the original films in accordance with the practice recommended in Clause 7 of ISO 2504:1973.

**9.7.3** The cylinders shall not have any of the following imperfections as specified in ISO 5817:

- cracks, inadequate welds, lack of penetration or lack of fusion of the weld;
- any elongated inclusion or any group of rounded inclusions in a row, where the length represented over a weld length of  $12a$  is greater than 6 mm;
- any gas pore measuring more than  $(a/3)$  mm;
- any gas pore measuring more than  $(a/4)$  mm, which is 25 mm or less from any other gas pore;
- the total length of gas pores in a line added together shall be  $< 2a$ .

**9.7.4** One cylinder at the beginning and one cylinder at the end of each shift period from each welding machine shall be radiographed. 100 % of the length of the weld shall be radiographed. Another sample shall be selected and radiographed if any adjustments are made to the welding machine or welding parameters.

**9.7.5** Initial qualification of the weld process will include determination of process capability requiring a greater sampling quantity of the batch to ensure a high confidence level in the welding process. The inspection body shall certify appropriate process capability prior to a reduction in sampling frequency.

## **10 Tests on every cylinder**

A pressure/leak test, as follows, shall be carried out on every cylinder as offered for shipment.

All cylinders in each batch shall be subjected to a pressure and a leak test, with the cylinder valve used in actual operation installed, using helium gas to ensure structural integrity and to verify there is no leakage from the cylinder, weld, boss or valve. During testing, the pressure in the cylinder shall be increased at a controlled rate until the specified test pressure is reached. The leak rate of the cylinder shall be determined at test pressure using a helium leak detector.

The pressure source shall be isolated and vented; the settled test pressure shall not decline by more than 1 % for a minimum of 10 min.

Proper safety controls shall be in place for this testing to ensure that the testing is conducted in a safe manner.

Cylinder packages with valves attached having a leak rate exceeding  $1 \times 10^{-3}$  mbar-l/s and/or showing evidence of visual deformation shall be rejected.

Proper safety precautions shall be taken when initiating and performing these tests in case a defect is present in the weld that could cause serious injury in the event of a cylinder failure. It is very important that the operator use appropriate personal protection equipment and that another individual be present to provide assistance in the event of an unforeseen cylinder failure during these tests.

Proper safety precautions shall be taken when pressurizing cylinders with helium. Take measures to ensure safe operation and to contain any energy, which is considerably more than that in the hydraulic test, which can be released.

NOTE The pressure/leak test is typically the last qualification test.

## 11 Failure to meet verification and test requirements

In the event of a failure to meet verification and test requirements, re-testing or additional stress relief shall be undertaken, as follows.

- a) If there is evidence of a fault when carrying out a test or in case of an error of measurement, a further test shall be performed. If the result of this test is satisfactory, the first test shall be ignored.
- b) If the test has been carried out in a satisfactory manner, the cause of test failure shall be identified.
- c) If the failure is considered to be due to the stress relief applied, the manufacturer may subject all the cylinders of the batch to further stress relief, the conditions of which shall be the same as for the first stress relief.
- d) If the failure is not due to the stress relief applied, all the identified defective cylinders shall be rejected or repaired. The repaired cylinders are then considered a new batch.

The cylinders from the repaired batch and the remaining cylinders from the original batch shall become two separate batches.

In both cases the new batch shall be inspected and tested. Only the relevant tests needed to prove the acceptability of the new batch shall be performed again and shall prove satisfactory. If one or more tests prove even partially unsatisfactory, all the cylinders of the batch shall be rejected.

## 12 Marking

Each cylinder shall be permanently and legibly marked on a nameplate or other appropriate permanently attached non-pressure part, in accordance with ISO 13769. Permanent stampings shall also be allowed, in accordance with the requirements of this clause.

## 13 Certification

Each batch of cylinders shall be certified to the effect that the cylinders meet the requirements of this International Standard in all respects.

The certificate shall include:

- a) a reference to the design code;
- b) the type approval certificate number;
- c) the batch and serial numbers of the cylinders included in the certificate;
- d) a statement that the cylinders have been proof pressure and leak tested in accordance with this International Standard.



## Annex A (normative)

### Inspection at time of fill

#### A.1 Inspection at time of fill

##### A.1.1 Identification of cylinder for suitability for filling

This International Standard requires all cylinders to be dedicated to single-gas use for the entire service life of the cylinder. Prior to refilling a cylinder it shall be verified that the gas to be filled is the same gas as previously filled.

##### A.1.2 Visual inspection prior to fill

The external surface of each cylinder shall then be inspected for

- a) dents, cuts, gouges, bulges, cracks, laminations or excessive base wear,
- b) heat damage, torch or electric-arc burns,
- c) corrosion,
- d) other defects such as illegible, incorrect or unauthorized stamp markings, or unauthorized additions or modifications,
- e) integrity of all permanent attachments, and
- f) vertical stability, if relevant.

Cylinder-to-valve threads shall be examined to ensure that the threads of the valve and of the cylinder are of the same specification and in good condition.

When inspecting for corrosion, special attention shall be given to areas where water could be trapped.

Cylinders no longer suitable for future service shall be rendered unserviceable.

##### A.1.3 Check for correct fill pressure

The pressure of each filled cylinder shall be verified to be less than 1 standard atmosphere at 21 °C. Cylinders filled to a pressure greater than 1 standard atmosphere at 21 °C (overfilled) cannot be offered for carriage. Overfilled cylinders can be reworked (e.g. controlled venting to a scrubber) in order to reduce the fill pressure to less than 1 standard atmosphere at 21 °C. Cylinders that are successfully reworked can be offered for carriage.

NOTE Standard atmosphere = 14,7 PSIA = 760 mm Hg = 101 kPA.

##### A.1.4 Verification of tare weight

The tare weight of a new cylinder is equal to the sum of the weight of the cylinder, valve and any fixed valve guard and the mass of all other parts which are permanently attached (e.g. by bolted fixing or clamping and painting) to the cylinder when presented for filling. The filling scale used shall have a precision-to-tolerance ratio of 0,1 and a valid calibration. The filling scale used shall have a precision-to-tolerance of  $\leq 0,1$ , which indicates how much of the product specification tolerance is being consumed by the measuring error.

Prior to filling, the pressure of each used cylinder shall be measured in order to determine the residual weight of gas. The amount of residual gas remaining in a used cylinder is related to the pressure by an isotherm. The tare weight of the cylinder is equal to the weight of the used cylinder minus the residual weight of the contents.



### A.1.5 Check for proper fill weight

The weight of each filled cylinder shall be obtained using a filling scale. The filling scale used shall have a precision-to-tolerance ratio of 0,1 and a valid calibration. Proper operation of the scale is verified at each shift using a suitable calibration weight. After obtaining the weight of the filled cylinder, the amount of gas filled is determined by subtracting the tare weight of the cylinder from the filled weight of the cylinder. The gas weight shall meet specifications derived from adsorption isotherms that assure the sub-atmospheric storage of gas within the filled cylinder.

### A.1.6 Cylinder filling records

A database record shall be established and maintained by the filler at least for the life of the cylinder for each filled cylinder, which relates the serial number stamped on the cylinder and a minimum of the following information:

- fill date;
- required cylinder retest date;
- filling location;
- fill batch or lot number;
- gas type filled;
- fill weight;
- cylinder tare weight;
- fill pressure;
- media weight.



## Annex C (informative)

### Gases currently being transported

#### C.1 List of gases approved for carriage

Table C.1 lists the gases by UN number, name and description, and the P200 classification code, that are approved for carriage in pressure receptacles specified by this International Standard. Additionally, when applicable, the table indicates the special packaging provisions required by the UN Model Regulations, as per Table 2 of P200 of the UN Model Regulations for each entry in the table.

**Table C.1 — List of gases authorized for packaging under this International Standard**

UN number	Name and description	Special packaging provision as per Table 2 of P200 of the UN Model Regulations
UN1008	Boron trifluoride	None
UN2188	Arsine	d,k,r
UN2199	Phosphine	r,z
UN1859	Silicon tetrafluoride	None
UN3308	Liquefied gas, toxic, corrosive, N.O.S. (germanium tetrafluoride)	r,z
UN3308	Liquefied gas, toxic, corrosive, N.O.S. (arsenic pentafluoride)	r,z
UN2198	Phosphorous pentafluoride	k
UN3308	Liquefied gas, toxic, corrosive, N.O.S. (phosphorous trifluoride)	r,z
UN2202	Hydrogen selenide, anhydrous	k

#### C.2 Explanation of the special packaging provisions listed in Table C.1

d: When steel pressure receptacles are used, only those resistant to hydrogen embrittlement shall be authorized.

k: Valve outlets shall be fitted with gastight plugs or caps, which shall be made of material not liable to attack by the contents of the pressure receptacle.

Pressure receptacles shall not be fitted with a pressure relief device.

Each valve shall have a tapered threaded connection directly to the pressure receptacle and be capable of withstanding the test pressure of the pressure receptacle.

Each valve shall be either of the packless type with non-perforated diaphragm, or of a type which prevents leakage through or past the packing.

Each pressure receptacle shall be tested for leakage after filling.

r: Not applicable to this International Standard as this special provision applies only to carriage of gases in capsules.

## ISO 11513:2011(E)

z: The construction materials of the pressure receptacles and their accessories shall be compatible with the contents and shall not react to form harmful or dangerous compounds therewith.

The test pressure and filling ratio shall be calculated in accordance with the relevant requirements of (3) in P200 of the UN Model Regulations.

Toxic substances with an  $LC_{50}$  less than or equal to  $200 \text{ ml/m}^3$  shall not be transported in tubes, pressure drums or multiple-element gas containers (MEGCs) and shall meet the requirements of special packing provision k.

For pressure receptacles containing pyrophoric gases or flammable mixtures of gases containing more than 1 % pyrophoric compounds, the requirements of special packing provision q shall be met.

The necessary steps shall be taken to prevent dangerous reactions (i.e. polymerization or decomposition) during transport. If necessary, stabilization or addition of an inhibitor shall be required.

Mixtures containing UN 1911 diborane shall be filled to a pressure such that, if complete decomposition of the diborane occurs, two-thirds of the test pressure of the pressure receptacle shall not be exceeded.

NOTE Symbols are taken from the 16th edition of the UN Recommendations.

## Bibliography

- [1] ISO 4136, *Destructive tests on welds in metallic materials — Transverse tensile test*
- [2] ISO 4706:2008, *Gas cylinders — Refillable welded steel cylinders — Test pressure 60 bar and below*
- [3] ISO 5178, *Destructive tests on welds in metallic materials — Longitudinal tensile test on weld metal in fusion welded joints*
- [4] ISO 5817, *Welding — Fusion-welded joints in steel, nickel, titanium and their alloys (beam welding excluded) — Quality levels for imperfections*
- [5] ISO 9327 (all parts), *Steel forgings and rolled or forged bars for pressure purposes — Technical delivery conditions*
- [6] ISO 9606-1, *Approval testing of welders — Fusion welding — Part 1: Steels*
- [7] ISO 11114-1, *Transportable gas cylinders — Compatibility of cylinder and valve materials with gas contents — Part 1: Metallic materials*
- [8] ISO 11116-1, *Gas cylinders — 17E taper thread for connection of valves to gas cylinders — Part 1: Specifications*
- [9] ISO 11116-2, *Gas cylinders — 17E taper thread for connection of valves to gas cylinders — Part 2: Inspection gauges*
- [10] EN 13322-2, *Transportable gas cylinders — Refillable welded steel gas cylinders — Design and construction — Part 2: Stainless steel*
- [11] ISO 14732, *Welding personnel — Approval testing of welding operators for fusion welding and of resistance weld setters for fully mechanised and automatic welding of metallic materials*
- [12] ISO 15613, *Specification and qualification of welding procedures for metallic materials — Qualifications based on pre-production welding test*
- [13] ISO 16111, *Transportable gas storage devices — Hydrogen absorbed in reversible metal hydride*
- [14] ISO 17636, *Non-destructive testing of welds — Radiographic testing of fusion-welded joints*
- [15] ISO 21172-1, *Gas cylinders — Welded steel pressure drums up to 3 000 litres capacity for the transport of gases — Design and construction — Part 1: Capacities up to 1 000 litres*

---

---

**ICS 23.020.30**

Price based on 23 pages