

INTERNATIONAL
STANDARD

ISO
11503

First edition
1995-07-15

**Paints and varnishes — Determination of
resistance to humidity (intermittent
condensation)**

*Peintures et vernis — Détermination de la résistance à l'humidité (par
condensation intermittente)*



Reference number
ISO 11503:1995(E)

Foreword

ISO (the International Organization for Standardization) is a worldwide federation of national standards bodies (ISO member bodies). The work of preparing International Standards is normally carried out through ISO technical committees. Each member body interested in a subject for which a technical committee has been established has the right to be represented on that committee. International organizations, governmental and non-governmental, in liaison with ISO, also take part in the work. ISO collaborates closely with the International Electrotechnical Commission (IEC) on all matters of electrotechnical standardization.

Draft International Standards adopted by the technical committees are circulated to the member bodies for voting. Publication as an International Standard requires approval by at least 75 % of the member bodies casting a vote.

International Standard ISO 11503 was prepared by Technical Committee ISO/TC 35, *Paints and varnishes*, Subcommittee SC 9, *General test methods for paints and varnishes*.

Annex A forms an integral part of this International Standard.

© ISO 1995

All rights reserved. Unless otherwise specified, no part of this publication may be reproduced or utilized in any form or by any means, electronic or mechanical, including photocopying and microfilm, without permission in writing from the publisher.

International Organization for Standardization
Case Postale 56 • CH-1211 Genève 20 • Switzerland

Printed in Switzerland

Introduction

There is seldom a direct relationship between the resistance of organic coatings to the action of humidity and the resistance to deterioration in other environments. This is because the effect of each of the several factors influencing the progress of deterioration varies greatly with the conditions encountered. Therefore, the results obtained in this test should not be regarded as a direct guide to the resistance of the tested coatings in all environments where these coatings may be used. Also, performance of different coatings in the test should not be taken as a direct guide to the relative performance of these coatings in service. Nevertheless, the method described gives a means of checking that the quality of a paint or paint system is being maintained.

Paints and varnishes — Determination of resistance to humidity (intermittent condensation)

1 Scope

This International Standard is one of a series of standards dealing with the sampling and testing of paints, varnishes and related products.

It specifies a test method for determining under standard conditions the resistance of a single coat or a multi-coat system of paint or related material to intermittent water condensation. The method includes the testing of coatings on non-porous and on porous substrates.

2 Normative references

The following standards contain provisions which, through reference in this text, constitute provisions of this International Standard. At the time of publication, the editions indicated were valid. All standards are subject to revision, and parties to agreements based on this International Standard are encouraged to investigate the possibility of applying the most recent editions of the standards indicated below. Members of IEC and ISO maintain registers of currently valid International Standards.

ISO 1512:1991, *Paints and varnishes — Sampling of products in liquid or paste form.*

ISO 1513:1992, *Paints and varnishes — Examination and preparation of samples for testing.*

ISO 1514:1993, *Paints and varnishes — Standard panels for testing.*

ISO 2808:1991, *Paints and varnishes — Determination of film thickness.*

ISO 3270:1984, *Paints and varnishes and their raw materials — Temperatures and humidities for conditioning and testing.*

ISO 3696:1987, *Water for analytical laboratory use — Specification and test methods.*

ISO 4628-2:1982, *Paints and varnishes — Evaluation of degradation of paint coatings — Designation of intensity, quantity and size of common types of defect — Part 2: Designation of degree of blistering.*

ISO 8335:1987, *Cement-bonded particleboards — Boards of Portland or equivalent cement reinforced with fibrous wood particles.*

3 Principle

Coated specimens are placed in a cabinet or chamber containing a heated, saturated mixture of air and water vapour. The temperature of the cabinet or chamber is maintained at (40 ± 3) °C. At 98 % to 100 % relative humidity, the very small temperature difference between the specimen and the surrounding vapour causes the formation of condensation on the specimens.

This is an intermittent condensation test and after a period of time under these conditions the conditions in the cabinet or chamber are cycled to give (23 ± 5) °C and (50 ± 20) % relative humidity, i.e. dry conditions.

Water permeates the coating at rates that are dependent upon the characteristics of the coating. Any effects such as colour change, blistering, loss of adhesion, softening or embrittlement are observed and reported using criteria previously agreed between the interested parties, these criteria usually being of a subjective nature.

4 Required supplementary information

For any particular application, the test method specified in this International Standard needs to be completed by supplementary information. The items of supplementary information are given in annex A.

5 Apparatus

An airtight laboratory cabinet of capacity 300 litres as specified in 5.1 or a larger chamber of capacity 1 m³ or 2 m³ up to a walk-in chamber as specified in 5.2 shall be used.

5.1 Airtight cabinet, of capacity (300 ± 10) litres, in the base of which is a watertight trough fitted with a means of heating the water to meet the requirements of 8.4.

The dimensions and design of the cabinet are not critical, provided the requirements of 5.3 are met. It shall be constructed of an inert material and have a roof which prevents condensed moisture dripping on to the test specimens.

The cabinet shall be provided with a means of relieving excess pressure.

The cabinet shall also be provided with a means of controlling the temperature, which shall be measured in the space above the test specimens.

NOTE 1 Alternative designs of apparatus may be fitted with a door or a removable hood. Suitable designs of apparatus are shown in figures 1 and 2.

5.2 Airtight chamber, constructed of an inert material, with a window formed by two sheets of glass or other transparent material at a distance of 10 mm or more and with a roof which prevents condensed moisture dripping on to the test specimens.

The chamber shall be provided with a means of relieving excess pressure.

Insulation of the enclosure is not required.

In the base of the chamber is a watertight trough filled with heated water to a depth of at least 10 mm. The lateral dimensions of the trough shall correspond to the area used to expose the test specimens. The chamber shall be provided with a door or a removable hood. If a walk-in chamber is used, it shall be provided with a ventilator and an air outlet capable of generating about 10 air changes per hour.

The chamber is used with the equipment described in 5.2.1 to 5.2.3.

5.2.1 Heated water tank, outside the test chamber, connected to the trough, a pump, a supply of water of grade 2 quality as defined in ISO 3696, and a water-level control. The pump shall be capable of changing the water in the trough about four times per hour to meet the requirements of 8.4.

5.2.2 Thermostatic-control unit for the heater in the water tank, with the sensor located in the middle of the chamber at the uppermost specimen-exposure level.

5.2.3 Thermometer, with its sensor located adjacent to the thermostatic control sensor (5.2.2).

NOTE 2 If a walk-in chamber is used, it is preferable to install more than one thermometer and have the reading permanently recorded.

5.3 Specimen-suspension/support equipment.

Test panels shall normally be suspended, using synthetic-fibre or other inert insulating material. If, however, the test panels are exposed in racks, the racks shall be made of inert material and shall on no account impede the free convection of the air/water-vapour mixture. By agreement between the interested parties, painted specimens of different shapes may be exposed. These specimens shall be exposed in their normal attitude in use. Test panels shall be exposed vertically at least 100 mm from any wall or cover, at least 20 mm from each other and with the lower edges of the panels at least 200 mm above the water. Panels should preferably be placed at one level within the cabinet or chamber. In any case, care shall be taken to ensure that water which condenses on the upper panels does not drip on to the lower panels.

Coated specimens, including panels, with dimensions larger than those specified in 7.1.1 shall be exposed so that their lower edges are above the lowest level that gives condensation.

NOTE 3 It may be necessary to place the specimens in the upper part of the cabinet as the temperature differences at the lower levels may be too small to induce condensation.

5.4 Environmental cabinet (optional, see 8.4), capable of being maintained at a temperature of (23 ± 5) °C and a relative humidity of (50 ± 20) %, and including a stand for test panels

6 Sampling

Take a representative sample of the product to be tested (or of each product in the case of a multi-coat system), as described in ISO 1512.

Examine and prepare each sample for testing, as described in ISO 1513.

7 Test panels

7.1 Substrate

The substrate can be a non-porous or porous material equivalent to that on which the coating material under test is designed to be used in practice (see annex A).

7.1.1 Non-porous substrates

Unless otherwise specified or agreed, select as the substrate one of the test panels described in ISO 1514 of approximate dimensions 150 mm × 100 mm.

7.1.2 Porous substrates

Unless otherwise specified or agreed, the panels shall be flat fibre-cement sheets complying with the requirements for type A of ISO 8335 and of approximate dimensions 300 mm × 200 mm × 4 mm.

7.2 Preparation and coating of panels

Unless otherwise specified or agreed, prepare the test panels in accordance with ISO 1514 and then coat them with the product or system under test by the specified method (see annex A).

The back and the edges of the panels shall also be coated with the product or system under test, unless otherwise specified or agreed (see annex A).

7.3 Drying and conditioning

Dry (or stove) and age (if applicable) each coated panel for the specified time and under the specified conditions. Unless otherwise specified, condition them at (23 ± 2) °C and a relative humidity of (50 ± 5) % for a minimum of 16 h, with free circulation of air and without exposing them to direct sunlight. The test procedure shall then be carried out as soon as possible.

7.4 Thickness of coating

Determine the thickness, in micrometres, of the dry coating, by one of the non-destructive procedures specified in ISO 2808.

8 Procedure

Carry out the determination in duplicate unless otherwise agreed.

8.1 Ambient conditions

Set up the apparatus (see clause 5) in a room with a clean atmosphere and a temperature of (23 ± 5) °C and relative humidity of (50 ± 20) %. The apparatus shall be protected from draughts and direct sunlight.

8.2 Filling the trough

Fill the trough (see 5.1 or 5.2) and the heated water tank (5.2.1) with water to a depth of at least 10 mm. The depth shall be maintained at at least 10 mm at all times during the test.

Use water of grade 2 purity as defined in ISO 3696. The water should preferably be renewed prior to each heating operation but shall be renewed if it contains visible contaminants.

8.3 Arrangement of test specimens

Arrange the test specimens in the cabinet or chamber in accordance with 5.3 and close the apparatus.

8.4 Test cycle

The test cycle shall be

16 h at a temperature of (40 ± 3) °C and a relative humidity of 100 % (condensation period);

8 h at a temperature of (23 ± 5) °C and a relative humidity of (50 ± 20) % (dry period).

Switch on the heating appliance and raise the air temperature to (40 ± 3) °C in not more than 1,5 h. Maintain this temperature for a total period of 16 h from the commencement of the test cycle. At the end of this period, carry out an interim examination of the test specimens, then:

- a) switch off the heating appliance and either open the door completely or raise the hood of the apparatus to at least the upper edge of the test specimens

or

- b) if a walk-in chamber (5.2) is used, switch off the heating appliance and use the ventilator to obtain ambient conditions

or

- c) transfer the specimens to an environmental cabinet (5.4).

After 8 h, replace the test specimens in the airtight cabinet or chamber, change the water and repeat the cycle for the specified number of cycles.

Normally, cycles should follow without interruption but, if breaks occur, for example for the weekend, record this fact in the test report.

NOTES

4 During the condensation cycle, droplets of condensation should be visible on all parts of the specimens at all times if the apparatus is operating properly.

5 Due to absorption of heat by the specimens and heat losses through the walls of the cabinet, the temperature of the water in the trough will be above the temperature of the air/water-vapour mixture. The water temperature should preferably not exceed 60 °C, however, in order to prevent the formation of visible vapour.

8.5 Examination of test specimens

On completion of the test, which shall end with a condensation period, remove the specimens from the apparatus and wipe them dry. Immediately examine the whole test surface of each specimen for blistering in accordance with ISO 4628-2 and for other signs of deterioration.

Examine the specimens no less than 5 min and no more than 10 min after removal from the apparatus, as the effects produced by the condensation can change within a short time. Remove only as many specimens as can be examined within the specified time.

If required (see annex A), keep the specimens in the standard conditions defined in ISO 3270 for 24 h and examine the test surface again for loss of adhesion, rust staining, colour change, softening, embrittlement or other characteristics which may be specified (see annex A).

9 Precision

The concept of precision is not applicable to this International Standard (see clause 3).

10 Test report

The test report shall contain at least the following information:

- a) all details necessary to identify the product tested;
- b) a reference to this International Standard (ISO 11503);
- c) the items of supplementary information referred to in annex A;
- d) a reference to the international or national standard, product specification or other document supplying the information referred to in c) above;
- e) the result of the test as indicated in 8.5;
- f) the thickness of the coating, in micrometres, and the procedure which was used;
- g) the number of test cycles;
- h) any deviation from the test method specified;
- i) the date of the test.

Dimensions in millimetres

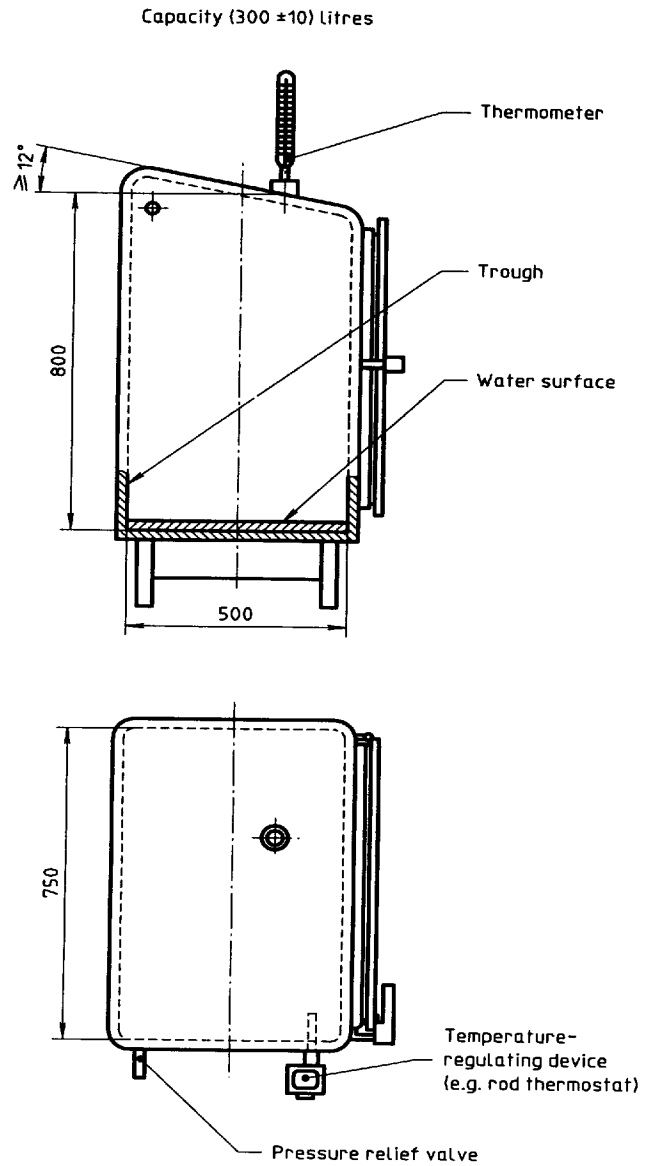

Figure 1 — Airtight cabinet with door

Dimensions in millimetres

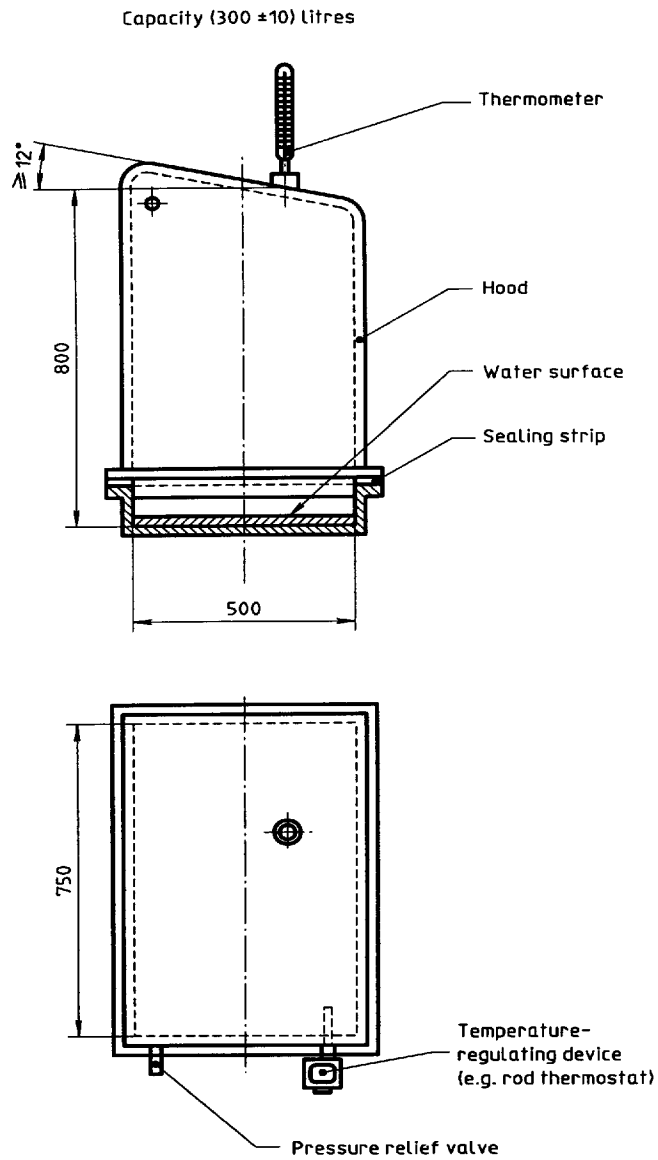

Figure 2 — Airtight cabinet with hood

Annex A

(normative)

Required supplementary information

The items of supplementary information listed in this annex shall be supplied as appropriate to enable the method to be carried out.

The information required should preferably be agreed between the interested parties and may be derived, in part or totally, from an international or national standard or other document related to the product under test.

- a) Substrate material and surface preparation of the substrate.
- b) Method of application of the test coating to the substrate, and whether the back of the substrate is coated.
- c) Duration and conditions of drying (or stoving) and ageing (if applicable) of the test specimens before testing.
- d) Thickness, in micrometres, of the dry coating and the method of measurement in accordance with ISO 2808, and whether it is a single coating or a multi-coat system.
- e) Number of test cycles.
- f) Type of apparatus, and whether a laboratory cabinet (5.1) or a chamber (5.2) is used.
- g) How inspection of the test coating is to be made, and what characteristics are to be considered in evaluating its resistance properties.

ICS 87.040

Descriptors: paints, varnishes, tests, water resistance tests, water vapour tests, condensation.

Price based on 7 pages
