**Road vehicles — Vehicle test methods for
electrical disturbances from narrowband
radiated electromagnetic energy —**

**Part 2:
Off-vehicle radiation sources**

*Véhicules routiers — Méthodes d'essai d'un véhicule soumis à des
perturbations électriques par rayonnement d'énergie électromagnétique
en bande étroite —*

Partie 2: Sources de rayonnement hors du véhicule



PDF disclaimer

This PDF file may contain embedded typefaces. In accordance with Adobe's licensing policy, this file may be printed or viewed but shall not be edited unless the typefaces which are embedded are licensed to and installed on the computer performing the editing. In downloading this file, parties accept therein the responsibility of not infringing Adobe's licensing policy. The ISO Central Secretariat accepts no liability in this area.

Adobe is a trademark of Adobe Systems Incorporated.

Details of the software products used to create this PDF file can be found in the General Info relative to the file; the PDF-creation parameters were optimized for printing. Every care has been taken to ensure that the file is suitable for use by ISO member bodies. In the unlikely event that a problem relating to it is found, please inform the Central Secretariat at the address given below.

© ISO 2005

All rights reserved. Unless otherwise specified, no part of this publication may be reproduced or utilized in any form or by any means, electronic or mechanical, including photocopying and microfilm, without permission in writing from either ISO at the address below or ISO's member body in the country of the requester.

ISO copyright office
Case postale 56 • CH-1211 Geneva 20
Tel. + 41 22 749 01 11
Fax + 41 22 749 09 47
E-mail copyright@iso.org
Web www.iso.org

Published in Switzerland

Contents

Page

Foreword	iv
1 Scope	1
2 Normative references	1
3 Terms and definitions	1
4 General test conditions	1
5 Test location	2
6 Test apparatus	3
7 Stimulation and monitoring of vehicle	5
8 Test set-up (see Figure 3)	5
9 Testing	6
Annex A (informative) Functional performance status classification (FPSC)	13

Foreword

ISO (the International Organization for Standardization) is a worldwide federation of national standards bodies (ISO member bodies). The work of preparing International Standards is normally carried out through ISO technical committees. Each member body interested in a subject for which a technical committee has been established has the right to be represented on that committee. International organizations, governmental and non-governmental, in liaison with ISO, also take part in the work. ISO collaborates closely with the International Electrotechnical Commission (IEC) on all matters of electrotechnical standardization.

International Standards are drafted in accordance with the rules given in the ISO/IEC Directives, Part 2.

The main task of technical committees is to prepare International Standards. Draft International Standards adopted by the technical committees are circulated to the member bodies for voting. Publication as an International Standard requires approval by at least 75 % of the member bodies casting a vote.

Attention is drawn to the possibility that some of the elements of this document may be the subject of patent rights. ISO shall not be held responsible for identifying any or all such patent rights.

ISO 11451-2 was prepared by Technical Committee ISO/TC 22, *Road vehicles*, Subcommittee SC 3, *Electrical and electronic equipment*.

This third edition cancels and replaces the second edition (ISO 11451-2:2001), which has been technically revised.

ISO 11451 consists of the following parts, under the general title *Road vehicles — Vehicle test methods for electrical disturbances from narrowband radiated electromagnetic energy*:

- *Part 1: General principles and terminology*
- *Part 2: Off-vehicle radiation sources*
- *Part 3: On-board transmitter simulation*
- *Part 4: Bulk current injection (BCI)*

Road vehicles — Vehicle test methods for electrical disturbances from narrowband radiated electromagnetic energy —

Part 2: Off-vehicle radiation sources

1 Scope

This part of ISO 11451 specifies a vehicle test method for determining the immunity of passenger cars and commercial vehicles to electrical disturbances from off-vehicle radiation sources, regardless of the vehicle propulsion system (e.g. spark-ignition engine, diesel engine, electric motor). It can also be readily applied to other types of vehicles.

The electromagnetic disturbances considered are limited to narrowband electromagnetic fields.

2 Normative references

The following referenced documents are indispensable for the application of this document. For dated references, only the edition cited applies. For undated references, the latest edition of the referenced document (including any amendments) applies.

ISO 11451-1:2001, *Road vehicles — Vehicle test methods for electrical disturbances from narrowband radiated electromagnetic energy — Part 1: General principles and terminology*

3 Terms and definitions

For the purposes of this document, the terms and definitions given in ISO 11451-1 apply.

4 General test conditions

The applicable frequency range of this test method is 0,01 MHz to 18 000 MHz. Testing over the full frequency range could require different field-generating devices, but this does not imply that testing of overlapping frequency ranges is required.

The user shall specify the test severity level or levels over the frequency range. Suggested test severity levels are given in Annex A.

See ISO 11451-1 for descriptions of, and requirements for, the following standard test conditions, applicable to this part of ISO 11451:

- test temperature;
- supply voltage;
- modulation;

- dwell time;
- frequency step sizes;
- definition of test severity levels;
- test signal quality.

5 Test location

The test should be performed in an absorber-lined shielded enclosure, the aim being to create an indoor electromagnetic compatibility testing facility that simulates open field testing.

The size, shape and construction of the enclosure may vary considerably. Typically, the floor is not covered with absorbing material, but such covering is allowed¹⁾. The minimum size of the shielded enclosure is determined by the size of the test region needed, the size of the field generation device or devices, the needed clearances between these and the largest vehicle to be tested, and the characteristics of the absorbing material. To create the test region, the absorber, field generation system and enclosure shape are selected such that the amount of extraneous energy in the test region is reduced to below a minimum value that will give the desired measurement accuracy. The design objective is to reduce the reflected energy in the test region to -10 dB or less over the test frequency range [not applicable to transmission line system (TLS) field generation systems]. An example of a rectangular shielded enclosure is shown in Figure 1.

Alternatively, the test may be performed at an outdoor test site. The test facility shall comply with (national) legal requirements regarding the emission of electromagnetic fields.

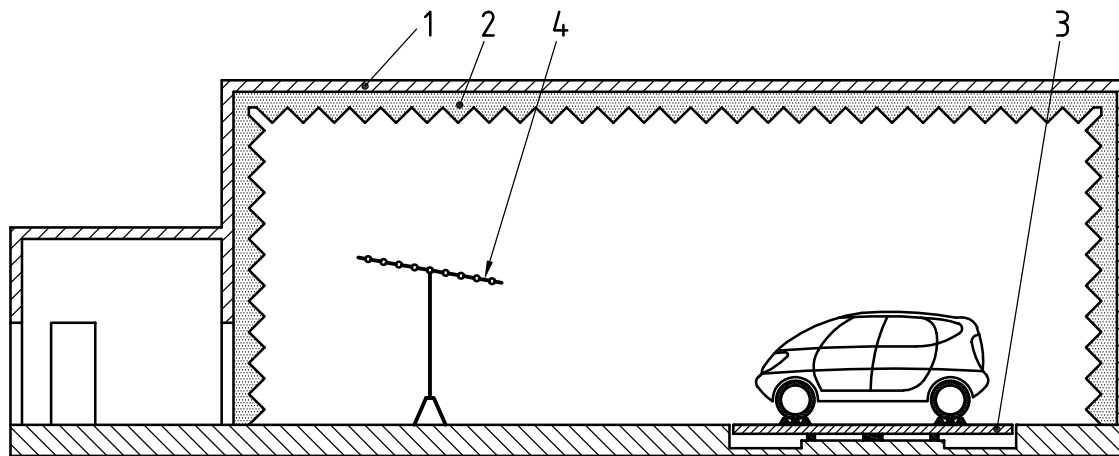

a) Vertical polarization

1) Measurements in enclosures with or without floor absorbers can lead to different results.

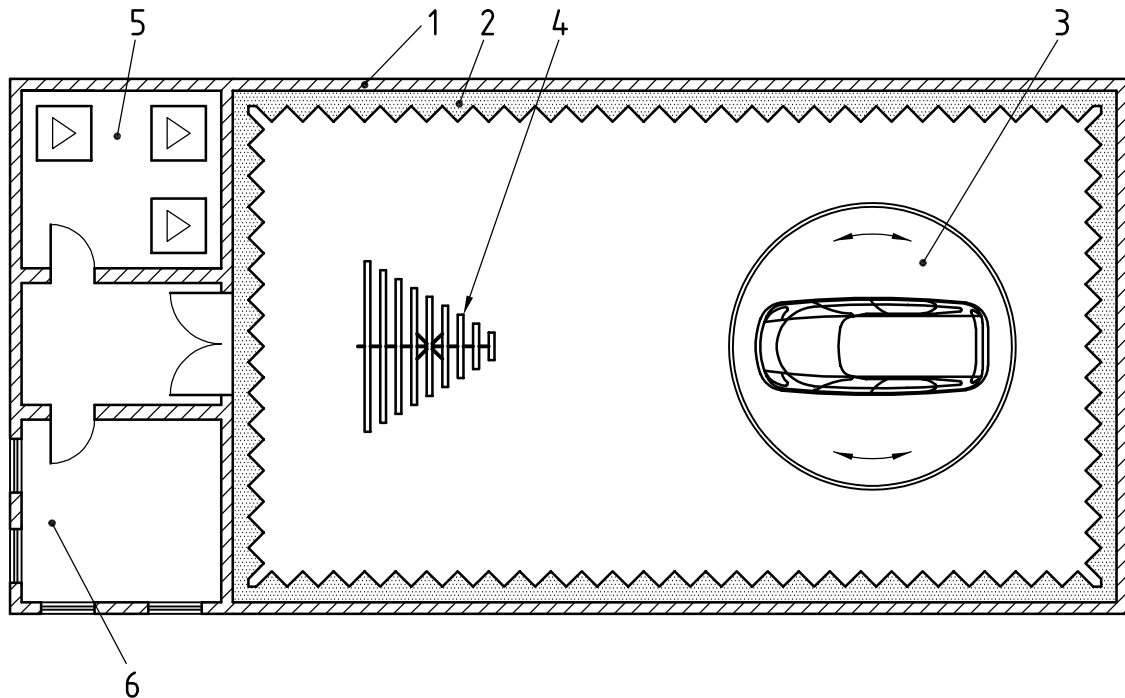

b) Horizontal polarization

Key

- 1 absorber-lined shielded enclosure
- 2 RF absorber material
- 3 vehicle dynamometer on turntable^a
- 4 antenna
- 5 amplifier room
- 6 control room

^a Turntable shown rotatable through $\pm 180^\circ$ with two pairs of variable wheelbase rollers to accommodate all vehicle sizes and functions.

Figure 1 — Example of absorber-lined shielded enclosure**6 Test apparatus**

Testing consists of generating radiated electromagnetic fields using antenna sets with radio frequency (RF) sources capable of producing the desired field strength over the range of test frequencies, for which the following apparatus/instrumentation shall be used.

6.1 Field generating device, which may be an antenna or antennas, or a TLS, and whose construction and orientation shall be such that the generated field can be polarized in the mode specified in the test plan (see 9.2).

See Figure 2 for an example of a parallel-plate TLS. Multiple antennas, amplifiers and directional couplers could be necessary to cover the complete frequency range.

6.2 field probe(s), which shall be electrically small in relation to the wavelength and isotropic.

The communication lines from the probes shall be fibre-optic links.

6.3 RF signal generator, with internal or external modulation capability.

6.4 High power amplifier(s).

6.5 Powermeter (or equivalent measuring instrument), for measuring forward and reflected power.

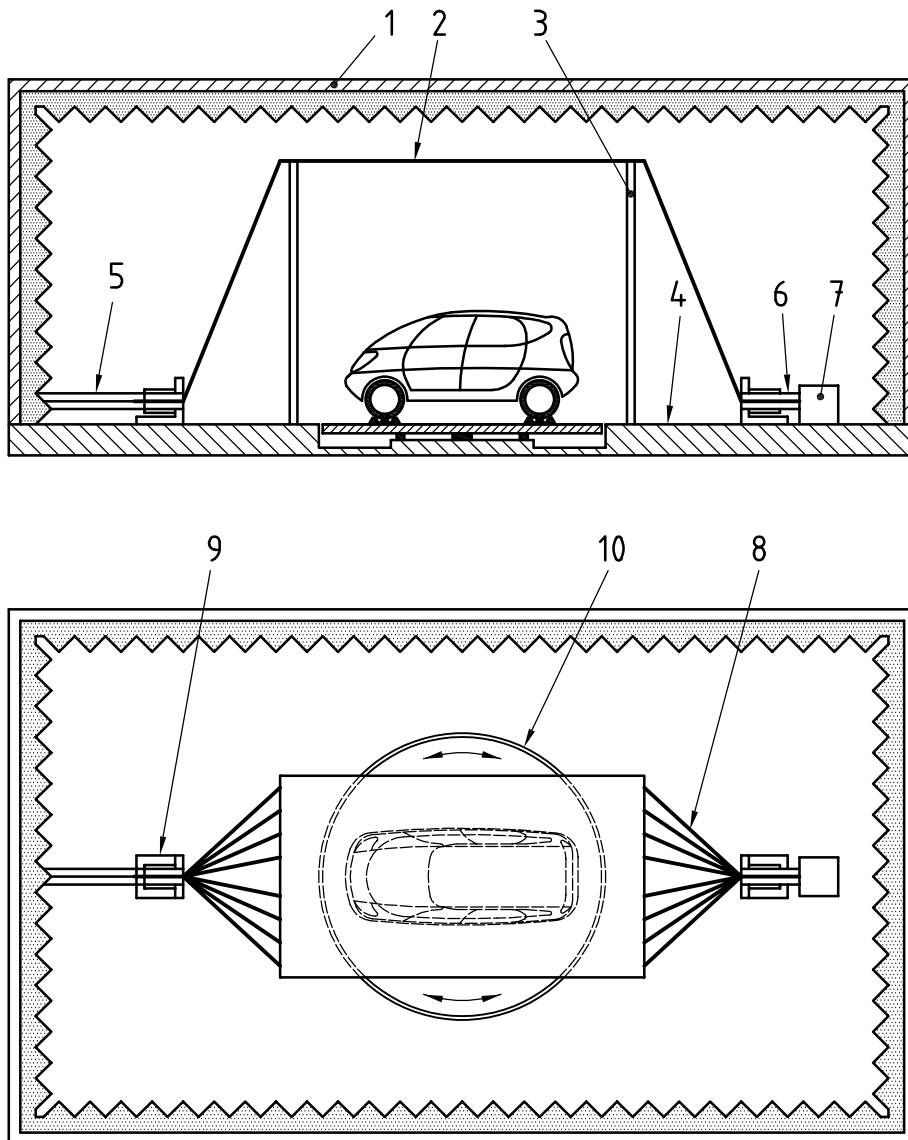

Key

- 1 shielded enclosure (absorbers permitted)
- 2 conductive plate or set of wires
- 3 non-metallic supports
- 4 shielded enclosure floor
- 5 signal source feed line (coaxial cable)
- 6 coaxial cable
- 7 load
- 8 conductive wires
- 9 signal source feed connection
- 10 turntable (not required for this test)

Figure 2 — Example of parallel-plate TLS

7 Stimulation and monitoring of vehicle

WARNING — Any electrical connection of monitoring equipment to the vehicle could cause malfunctions of the vehicle. Extreme care shall be taken to avoid such an effect.

The vehicle (the device under test or DUT) shall be operated as required in the test plan by using actuators which have a minimum effect on the electromagnetic characteristics, e.g. plastic blocks on the push-buttons, pneumatic actuators with plastic tubes.

Connections to equipment monitoring electromagnetic interference reactions of the vehicle may be accomplished by using fibre-optics or high-resistance leads. Other type of leads may be used but require extreme care to minimize interactions. The orientation, length and location of such leads shall be carefully documented to ensure repeatability of test results.

8 Test set-up (see Figure 3)

8.1 Vehicle placement

The vehicle shall be placed in the test region. The test region may contain a vehicle dynamometer, turntable or both these (see Figure 1).

8.2 Field generating device location (relative to vehicle and shielded enclosure)

8.2.1 General

The position or positions of the vehicle relative to the antenna or TLS shall be specified in the test plan (see 9.2).

The radiating elements of the field-generating device shall be no closer than 0,5 m to any absorbing material and no closer than 1,5 m to the wall of the shielded enclosure.

8.2.2 Antenna constraints

No part of the radiating antenna shall be closer than 0,5 m to the outer body surface of the vehicle.

The phase centre of the antenna shall be separated by at least 2 m horizontally from the reference point.

No part of an antenna's radiating elements shall be closer than 0,25 m to the floor.

There shall be no absorber material in the direct path between the transmitting antenna and the DUT.

8.2.3 TLS constraints

No part of a TLS, with the exception of the ground plane, shall be closer than 0,5 m to any part of the vehicle.

The TLS radiating element or elements shall be separated by at least 1 m vertically from the reference point (see 9.4.2).

The TLS shall extend centrally over at least 75 % of the length of the vehicle.

Particular care needs to be taken when testing heavy vehicles such as buses and large trucks. Under certain conditions related to dimensions and frequency, it is possible that close to 100 % of the applied power can be coupled to the vehicle by a directional coupler mechanism. Room resonances can also have a significant effect on the field uniformity, amplitude and direction under the TLS.

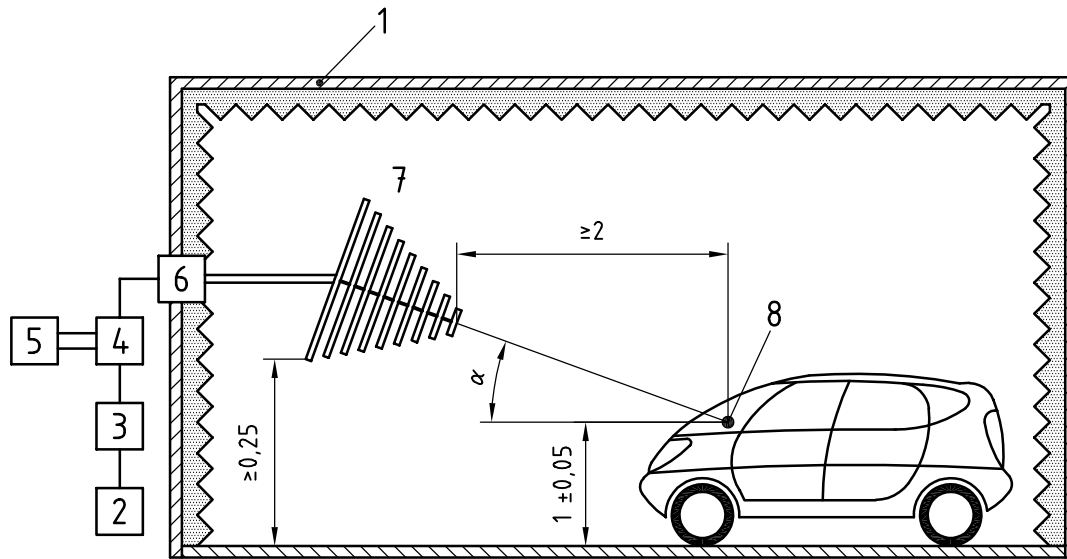

Key

- α tilt angle of antenna
- 1 absorber-lined shielded enclosure
- 2 RF signal generator
- 3 power amplifier
- 4 dual directional coupler
- 5 power meter
- 6 coaxial feedthrough
- 7 field generating device
- 8 vehicle reference point (see 9.4.2.2)

Figure 3 — Example of test set-up

9 Testing

9.1 Test conditions

The general arrangement of the disturbance source and vehicle represents a standardized test condition. Any deviations from the standard test configuration shall be agreed upon prior to testing and recorded in the test report. The vehicle shall be made to operate under typical loading and operating conditions. These operating conditions shall be clearly defined in the test plan. The orientation(s) of the vehicle for radiated immunity tests shall also be defined in the test plan.

9.2 Test plan

Prior to performing the tests, a test plan shall be generated which shall include

- test set-up,
- frequency range,
- reference point(s) (or line if four-probe method is used),
- vehicle mode of operation,

- vehicle acceptance criteria,
- definition of test severity levels,
- vehicle monitoring conditions,
- modulation,
- polarization,
- vehicle orientation,
- antenna location,
- test report content,
- any special instructions and changes from the standard test.

Every DUT shall be verified under the most significant situations, i.e. at least in stand-by mode and in a mode where all the actuators can be excited.

Additional vehicle positions, antenna locations or both could be needed to ensure complete illumination of the vehicle owing to the narrow beam widths of high-frequency antennas.

9.3 Test method

CAUTION — Hazardous voltages and fields can exist within the test area. Take care to ensure that the requirements for limiting the exposure of humans to RF energy are met.

The test shall be performed using the substitution method, which is based on the use of forward power as the reference parameter used for field calibration and during testing.

This method is performed in two phases:

- a) field calibration (without the vehicle present);
- b) test of vehicle.

The RF power required to achieve the required field strength is determined during the field calibration phase.

9.4 Field calibration

9.4.1 General procedure

Calibration is performed without a vehicle in the test location.

The specific test level (field) shall be calibrated periodically, using an unmodulated sinusoidal wave, by recording the forward power required to produce a specific field strength (measured with a field probe) for each test frequency.

The field strength shall be calibrated for vertical and horizontal polarizations.

When requested, the values of forward and reverse power recorded in the calibration file and a precise description of the associated position of the field probe shall be included in the test report.

Place the field generating device at the intended location. Place a calibrated isotropic field probe at the reference point or, alternatively, four calibrated isotropic field probes on the vertical reference line (see 9.4.2 and Figures 4 and 5).

Normally, the test facility reference point or line shall be used. Nevertheless, if it is not possible to establish the required field in the test region using the facility reference, the vehicle reference point may be used.

Above 200 MHz, the field uniformity at two points, one at 0,50 m on each side of the reference point, shall be within $\pm 0,6$ dB for at least 80 % of the test frequency points. For existing facilities where the field uniformity requirement cannot be met, this shall be stated in the test report. The user shall also ensure good reproducibility of the measurement.

Interpolation methods may be used between calibration levels to determine the specific forward power to be used for a test. From a practical viewpoint, the increment between calibration levels when the amplifier is operating in a linear range can be larger than when operating in a region where compression occurs.

9.4.2 Reference point and reference line

9.4.2.1 General

For the frequency ranges of 0,01 MHz to 20 MHz or 30 MHz and 2 GHz to 18 GHz, a single-field probe shall be used for calibration. A reference point is used with the single probe which is the point at which the field strength shall be established.

For the frequency range 20 MHz or 30 MHz to 2 GHz, the four-field probe calibration method shall be used. The mean of the four probes readings is used as the calibration value. A vertical reference line is used with the four-probe method which is a vertical line over which the field strength shall be established.

The 20 MHz or 30 MHz breakpoint is dependent on the design of the radiation source at the user's facility; typically the transformation from a TLS to an antenna.

9.4.2.2 Vehicle reference point and line

This is defined on the vehicle's centre line (plane of longitudinal symmetry), as follows.

a) Single-probe position:

- at a height of $(1 \pm 0,05)$ m above the shielded enclosure floor for vehicles with a roof height ≤ 3 m;
- at a height of $(2 \pm 0,05)$ m for vehicles with roof heights > 3 m.

Other heights may be specified and measured.

b) Four-probe positions:

- at heights of 0,5 m, 0,8 m, 1 m and 1,2 m, for vehicles with a roof height ≤ 3 m;
- at heights of 1,2 m, 1,5 m, 1,8 m and 2,1 m, for vehicles with a roof height > 3 m.

Depending on vehicle geometry, the vehicle reference point shall be located $(0,2 \pm 0,2)$ m behind the front axle (see Figure 4), or $(1 \pm 0,2)$ m inside the vehicle, measured from the point of intersection of the vehicle windscreen and hood (see Figure 5), whichever results in a reference point closer to the antenna.

NOTE The alternative locations on the vehicle could necessitate the recording of a family of calibration data based on the reference point location relative to the chamber, i.e. the front axle dynamometer position moves with vehicle wheelbase adjustment.

Dimensions in metres

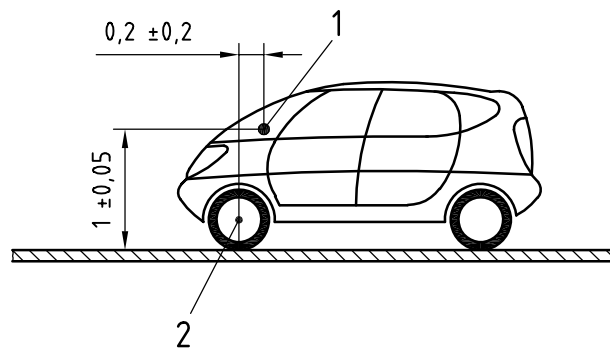

Key

- 1 vehicle reference point
- 2 front axle

Figure 4 — Example of vehicle reference point — Passenger cars and light commercial vehicles

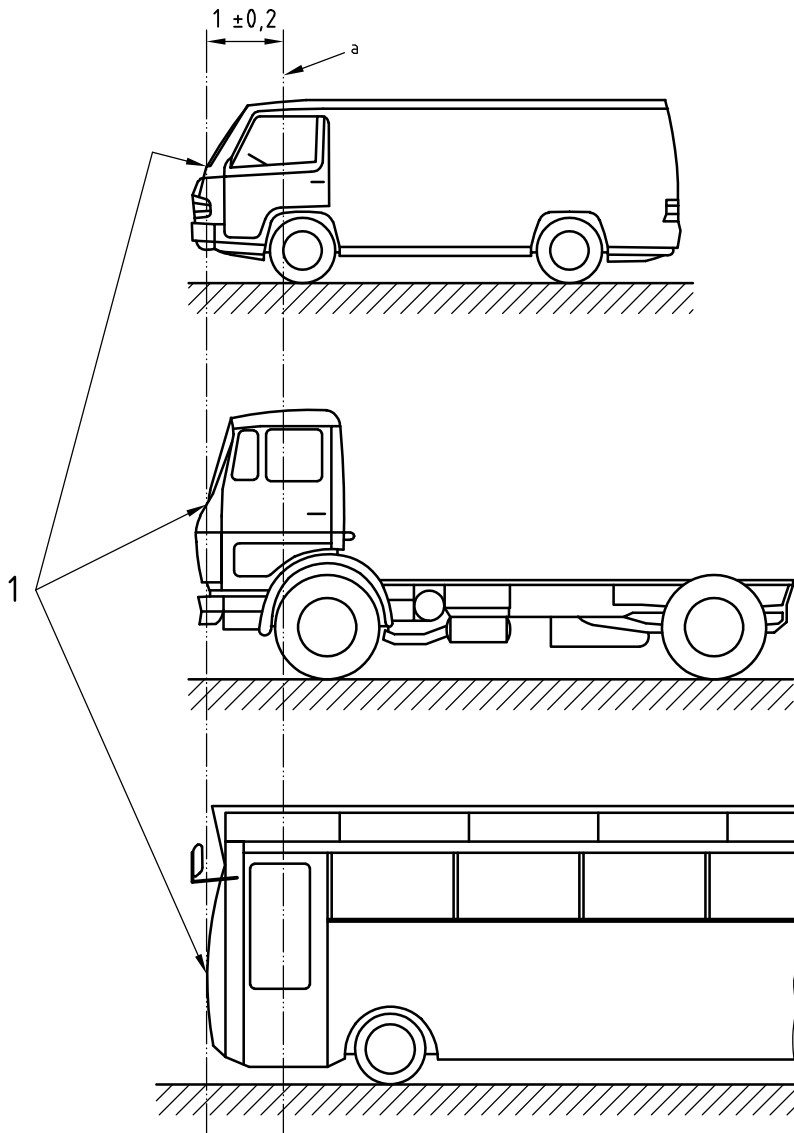

Key

1 intersection of windscreen and bonnet

NOTE Not drawn to scale.

a Vehicle reference point lies in this line.

Figure 5 — Example of vehicle reference point — Buses and commercial vehicles

9.4.2.3 Facility reference point and reference line

These are defined at the centre of the test region, as follows.

a) Single-probe position:

- at a height of $(1 \pm 0,05)$ m above the shielded enclosure floor for vehicles with a roof height ≤ 3 m;
- at a height of $(2 \pm 0,05)$ m for vehicles with a roof height > 3 m.

Other heights may be specified and measured.

b) Four-probe positions:

- at heights of 0,5 m, 0,8 m, 1 m and 1,2 m for vehicles with a roof height ≤ 3 m;
- at heights of 1,2 m, 1,5 m, 1,8 m and 2,1 m for vehicles with a roof height > 3 m.

Examples of test set-ups for single-probe and four-probe position calibration are shown in Figures 6 and 7.

Dimensions in metres

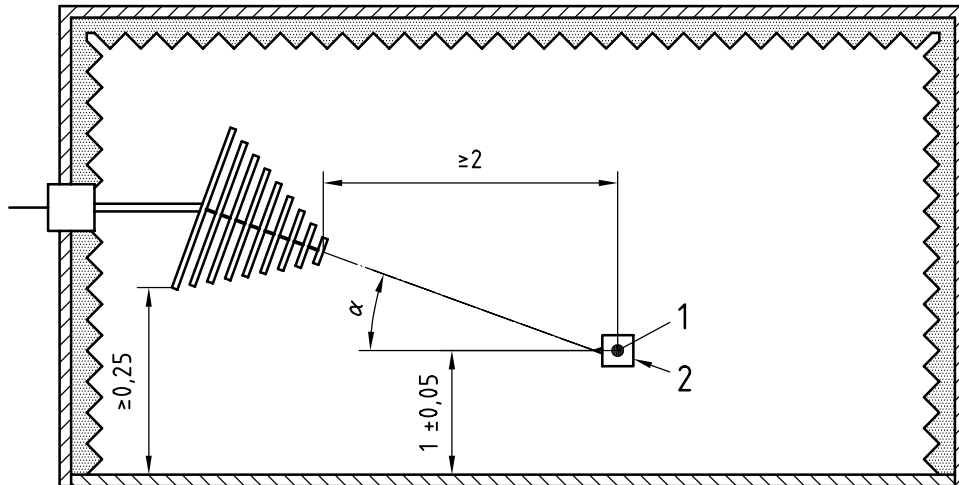

Key

- α tilt angle of antenna
- 1 reference point
- 2 field probe

Figure 6 — Example of test set-up — Single-probe position calibration (vehicle with roof height ≤ 3 m)

Dimensions in metres

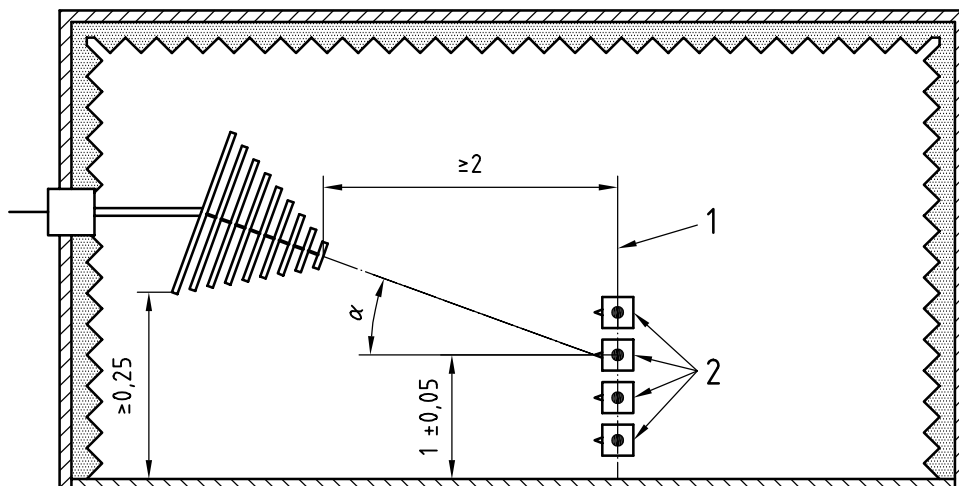

Key

- α tilt angle of antenna
- 1 reference line
- 2 probe positions

Figure 7 — Example of test set-up — Four-probe position calibration (vehicle with roof height ≤ 3 m)

9.5 Test procedure

Install the vehicle and associated equipment in the test location according to Clause 8 (see Figure 3). The vehicle shall operate according to the test plan (see 9.2).

Subject the vehicle to the test signal based on the calibrated value as predetermined in the test plan.

A field probe may be placed in or outside the vehicle during the test.

Conduct the test using both horizontally and vertically polarized fields over the test frequency range. Any exceptions to this practice shall be specified in the test plan.

With the field generating device in the specified polarization, scan the frequency range at the test level, noting any anomalies.

Continue testing until all frequencies, modulations, polarizations, vehicle orientations and antenna locations specified in the test plan are completed.

9.6 Test report

As required by the test plan, a test report shall be submitted detailing information regarding the test equipment, test site, test set-up, systems tested, frequencies, power levels, system interactions and any other information relevant to the test.

Annex A (informative)

Functional performance status classification (FPSC)

Suggested test levels and the frequency bands applicable to this part of ISO 11451 are given in Tables A.1 and A.2. See ISO 11451-1, Annex A, for a detailed explanation of the application of FPSC.

Table A.1 — Suggested test severity levels

Test severity level	Value V/m
I	25
II	50
III	75
IV	100
V	Specific value agreed between the users of this part of ISO 11451 if necessary.

Table A.2 — Suggested frequency bands

Frequency band	Frequency range MHz
F1	$\geq 0,01$ to ≤ 10
F2	> 10 to $\leq 30^a$
F3	$> 30^a$ to ≤ 200
F4	> 200 to $\leq 1\ 000$
F5	$> 1\ 000$ to $\leq 8\ 000$
F6	$> 8\ 000$ to $\leq 18\ 000$

^a This breakpoint may be lowered to 20 MHz, based on the facility field-generating system capabilities.

ICS 33.100.20; 43.040.10

Price based on 13 pages