

INTERNATIONAL STANDARD

ISO 11450

First edition
1999-10-15

Equipment for harvesting and conservation — Round balers — Terminology and commercial specifications

*Matériel de récolte et de conservation — Presses à balles rondes —
Terminologie et spécifications commerciales*



Reference number
ISO 11450:1999(E)

Contents

1 Scope	1
2 Normative references	1
3 Terms and definitions	1
4 Round baler classes	4
5 Bale specifications	4
6 Baler specifications	5
7 Pickup specifications	5
8 Bale formation specifications	6
9 Wrapping system specifications	6
10 Miscellaneous specifications	7
11 Tractor specifications	7

© ISO 1999

All rights reserved. Unless otherwise specified, no part of this publication may be reproduced or utilized in any form or by any means, electronic or mechanical, including photocopying and microfilm, without permission in writing from the publisher.

International Organization for Standardization
Case postale 56 • CH-1211 Genève 20 • Switzerland
Internet iso@iso.ch

Printed in Switzerland

Foreword

ISO (the International Organization for Standardization) is a worldwide federation of national standards bodies (ISO member bodies). The work of preparing International Standards is normally carried out through ISO technical committees. Each member body interested in a subject for which a technical committee has been established has the right to be represented on that committee. International organizations, governmental and non-governmental, in liaison with ISO, also take part in the work. ISO collaborates closely with the International Electrotechnical Commission (IEC) on all matters of electrotechnical standardization.

International Standards are drafted in accordance with the rules given in the ISO/IEC Directives, Part 3.

Draft International Standards adopted by the technical committees are circulated to the member bodies for voting. Publication as an International Standard requires approval by at least 75 % of the member bodies casting a vote.

International Standard ISO 11450 was prepared by Technical Committee ISO/TC 23, *Tractors and machinery for agriculture and forestry*, Subcommittee SC 7, *Equipment for harvesting and conservation*.

Introduction

The purpose of this International Standard is to improve the accuracy of communication among people involved in the design, manufacture or operation of round balers by defining terminology used and characteristics to be specified to define and compare round balers.

The design and configuration of round balers and associated equipment, hazard control and accident prevention depend on the awareness, concern and prudence of personnel involved in the operation, transport, maintenance and storage of such equipment.

Equipment for harvesting and conservation — Round balers — Terminology and commercial specifications

1 Scope

This International Standard establishes terminology and the content of commercial literature specifications for round balers as defined in 3.2.

2 Normative references

The following normative documents contain provisions which, through reference in this text, constitute provisions of this International Standard. For dated references, subsequent amendments to, or revisions of, any of these publications do not apply. However, parties to agreements based on this International Standard are encouraged to investigate the possibility of applying the most recent editions of the normative documents indicated below. For undated references, the latest edition of the normative document referred to applies. Members of ISO and IEC maintain registers of currently valid International Standards.

ISO 4251-1:1998, *Tyres (ply rating marked series) and rims for agricultural tractors and machines — Part 1: Tyre designation and dimensions, and approved rim contours*

ISO 4254-1:1989, *Tractors and machinery for agriculture and forestry — Technical means for ensuring safety — Part 1: General.*

ISO 5673:1993, *Agricultural tractors and machinery — Power take-off drive shafts and position of power-input connection.*

ISO 7867-1:1996, *Tyres and rims (metric series) for agricultural tractors and machines — Part 1: Tyre designation, dimensions, marking and tyre/rim coordination.*

ISO 8016:1985, *Machinery for agriculture — Wheels with integral hub.*

3 Terms and definitions

3.1

round bale

compressed cylindrical volume of an agricultural crop

NOTE 1 This allows easier mechanical handling and storage of the crop.

NOTE 2 “Round bale” is also referred to as “bale” in this International Standard.

3.2

round baler

machine that produces a round bale of agricultural materials

NOTE “Round baler” is also referred to as “baler” in this International Standard.

3.3 Pickup and feeding

3.3.1

pickup

device to gather and move the crop into the baler

3.3.2

tine bar pickup

pickup consisting of a rotor with tines that rotates about an axis transverse to the movement of the baler and is located between stationary strippers

3.3.3

pickup gauge wheel

ground wheel or wheels attached to the pickup to provide constant pickup height control and protect components from ground damage

3.3.4

windguard

casing assembly that keeps the crop near the arc-path of the pickup tines to control feeding of the crop into the baler/bale chamber

3.3.5

converging wheels

rotating elements located on the sides and front of the pickup which displace the crop laterally into the pickup

3.3.6

converging pickup

pickup with the means to displace the crop laterally into the baler

3.3.7

feed rollers

powered rollers located behind the pickup that deliver the crop to the opening of the bale chamber

3.3.8

feed rake

feeder fork device located behind the pickup that delivers the crop to the opening of the bale chamber

3.3.9

feed rotor

feed rotor located behind the pickup that delivers the crop into the opening of the bale chamber

3.4

bale chamber

cavity in which the bale is formed

3.4.1

fixed chamber baler

baler that produces a bale with a diameter of one size

3.4.2

variable chamber baler

baler that produces bales of variable diameter

3.5

wrapping

application of wrapping material(s) around the bale

3.6

bale wrapping material

any material used to contain the bale and preserve the bale quality and shape

3.6.1**twine**

any cord-like material used to wrap bales around the circumference

3.6.1.1**twine spacing**

average distance between adjacent twine strands on the bale, disregarding the end wraps

3.6.2**net**

any material of multiple longitudinal and lateral strands linked or fused together used to wrap bales around the circumference

3.6.3**film**

any thin sheet bale wrapping material

NOTE Usually for completely covering the bale.

3.7 Monitoring functions**3.7.1****bale shape indicator**

means of indicating the relative bale profile during bale formation

3.7.2**bale size indicator**

means of indicating the relative bale diameter during formation

3.7.3**bale near-full indicator**

means of indicating that the bale is nearing the set bale diameters

3.7.4**wrapping movement indicator**

means of indicating that the bale wrapping material is being applied to the bale

3.7.5**twine indicator**

means of indicating the twine applicator position during the wrapping cycle

3.8 Miscellaneous**3.8.1****gate**

movable part of the baler casing which can be raised allowing the completed bale to be discharged

3.8.2**bale discharge device**

mechanism that discharges the bale beyond the gate

4 Round baler classes

A round baler shall be classed according to maximum bale volume produced and designated according to Table 1.

Table 1 — Baler classes

Class	Bale volume V m^3
Class I	$V < 1,6$
Class II	$1,6 \leq V < 2,5$
Class III	$2,5 \leq V < 3,5$
Class IV	$V > 3,5$

5 Bale specifications

5.1 Bale diameter

5.1.1 Specification

Specify the bale diameter(s) produced by the baler, including the maximum and minimum diameters for variable chamber balers, in millimetres.

5.1.2 Determination

5.1.2.1 Measure the circumference of the bale 150 mm from each end of the bale.

5.1.2.2 Average the two circumferences and divide by 3,14 to obtain the bale diameter.

5.1.2.3 The specified bale diameter shall be determined by averaging the bale diameters of at least three randomly selected bales. The bales shall be less than 24 hours old and shall not have been rained upon.

5.2 Bale width

Specify the overall bale width, in millimetres.

5.3 Bale volume

Specify the bale volume calculated in cubic metres to the nearest tenth cubic metre, using bale diameter and bale width as determined in 5.1.2 and 5.2.

5.4 Bale mass

Specify the bale mass rounded to the nearest kilogram. Wrapping material shall be included in this mass. The bale crop moisture content (wet basis) shall be specified.

5.5 Bale density

Specify the bale mass divided by the bale volume, in kilograms per cubic metre, calculated using bale volume and bale mass as determined in 5.3 and 5.4.

6 Baler specifications

6.1 Conditions

Specification of the baler characteristics given in 6.2 to 6.5 is subject to the following conditions:

- balers shall be equipped for field operation;
- all equipment options shall be specified;
- the bale chamber shall be empty;
- the tyres shall be inflated to the manufacturer's recommended pressure;
- the baler hitch height shall be specified when measuring the baler length and height.

6.2 Baler mass

Specify the mass of a complete unit, rounded to the nearest kilogram.

6.3 Baler length

Specify the horizontal distance from the foremost point to the rearmost point of the baler, in millimetres, with gate closed ($L1$) and gate open ($L2$) (see Figure 1).

6.4 Baler height

Specify the vertical distance from the ground plane to the highest point of the baler, with gate closed ($H1$) and gate open ($H2$) (see Figure 1).

6.5 Baler width ($W1$)

Specify the horizontal distance, in millimetres, from the left-hand most point to the right-hand most point on the baler. Specify both operating and transport widths (see Figure 1).

7 Pickup specifications

7.1 Tine bars

Specify the total quantity of tine bars in the pickup.

7.2 Tines

Specify the total quantity of single tines in the pickup.

7.3 Tine spacing

Specify the horizontal distance between tines, in millimetres.

7.4 Pickup width ($W2$)

Specify the horizontal distance between the outer most tines, in millimetres (see Figure 1).

7.5 Pickup gauge wheel

Specify the wheel size, state whether or not it is adjustable, and availability of right-hand and/or left-hand location.

8 Bale formation specifications

8.1 Bale chamber

8.1.1 Specify the characteristics given in 8.1.2 to 8.1.4 as fixed or variable.

8.1.2 Bale chamber width, in millimetres, calculated using the inside width of the bale forming sheets;

8.1.3 Fixed bale chamber diameter, in millimetres, calculated using the inside width of the bale forming sheets;

8.1.4 Variable bale chamber diameter minimum and maximum, in millimetres.

8.2 Bale forming elements

Specify the primary element(s) contacting the bale circumference.

8.2.1 Apron chains

Specify the chain size and length in millimetres.

8.2.2 Belts

Specify the quantity, width and length in millimetres, construction (plies and texture) and type of splice.

8.2.3 Rollers

Specify the quantity, diameter in millimetres and surface texture.

8.3 Density control

Specify the primary energy source providing density control and indicate if the control is fixed or adjustable.

8.4 Bale diameter control

Specify as automatic or manual and indicate if the control is fixed or adjustable.

8.5 Overfill protection

Specify the means to prevent overfilling the baler.

9 Wrapping system specifications

9.1 Wrapping control

Specify as manual, automatic or automatic with manual starter.

9.2 Wrapping material

9.2.1 Twine

9.2.1.1 Specify if the twine spacing is fixed, incrementally adjustable or infinitely adjustable.

9.2.1.2 Specify the number of twine applicators working during the wrapping cycles.

9.2.2 Film or net

Specify if the number of wraps around the bale is fixed or adjustable.

9.3 Wrapping material storage

9.3.1 Twine

9.3.1.1 Quantity

Specify the quantity of twine balls capable of being stored on the baler.

9.3.1.2 Twine ball size

The twine ball storage shall accommodate a ball size with a maximum height of 265 mm and a maximum diameter of 255 mm.

9.3.2 Net or film

9.2.2.1 Specify the quantity of net or film rolls capable of being stored on the baler.

9.2.2.2 Specify the net or film size of rolls.

10 Miscellaneous specifications

10.1 Monitoring systems

Specify which monitoring functions are provided.

10.2 Tyres

10.2.1 Specify tyre code, tyre size, ply rating and inflation pressure.

10.2.2 Wheels and tyres shall conform to the ISO 4251-1, 7867-1 and 8016.

10.3 Baler primary drive

10.3.1 Type

Specify as with single universal joints or with centred double universal joints.

10.3.2 Size

Specify the size of drive shaft according to ISO 5673.

10.3.3 Overload protection

Specify as slip clutch, cut-out clutch or shear bolt.

11 Tractor specifications

Specify the following tractor requirements to operate a field-equipped baler.

11.1 Power

Specify the minimum PTO power, in kilowatts.

11.2 Electrical

Specify the following:

- nominal voltage in volts;
- minimum current in amperes;
- ground polarity as positive or negative.

11.3 Hydraulics

11.3.1 Pressure

Specify the minimum pressure in kilopascals.

11.3.2 Flow

Specify the minimum and maximum flow rates in litres per minute at rated pressure.

11.3.3 Hydraulic outlets

Specify the quantity of single or double acting remote outlets required.

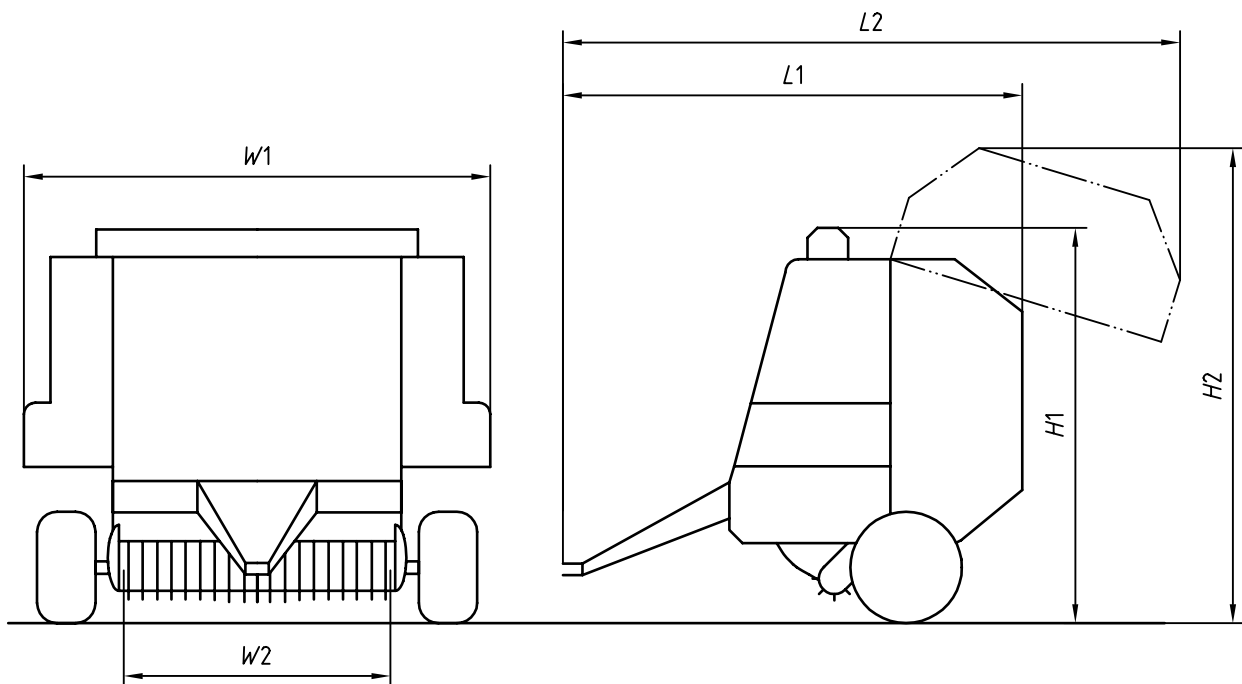

- $L1$ Baler length (gate closed)
- $L2$ Baler length (gate open)
- $H1$ Baler height (gate closed)
- $H2$ Baler height (gate open)
- $W1$ Baler width
- $W2$ Pickup width

Figure 1 — Dimensions of round baler

ICS 01.040.65; 65.060.50

Price based on 8 pages
