

---

---

**Road vehicles — Connectors for the  
electrical connection of towing and  
towed vehicles —**

**Part 2:  
13-pole connectors for vehicles with  
12 V nominal supply voltage intended to  
cross water fords**

*Véhicules routiers — Connecteurs pour liaisons électriques entre  
véhicules tracteurs et véhicules tractés —*

*Partie 2: Connecteurs à 13 contacts pour véhicules à tension  
d'alimentation nominale de 12 V destinés à traverser des gués*



.....



## **COPYRIGHT PROTECTED DOCUMENT**

© ISO 2012

All rights reserved. Unless otherwise specified, no part of this publication may be reproduced or utilized in any form or by any means, electronic or mechanical, including photocopying and microfilm, without permission in writing from either ISO at the address below or ISO's member body in the country of the requester.

ISO copyright office  
Case postale 56 • CH-1211 Geneva 20  
Tel. + 41 22 749 01 11  
Fax + 41 22 749 09 47  
E-mail [copyright@iso.org](mailto:copyright@iso.org)  
Web [www.iso.org](http://www.iso.org)

Published in Switzerland

# Contents

Page

Foreword .....	iv
<b>1 Scope .....</b>	<b>1</b>
<b>2 Normative references .....</b>	<b>1</b>
<b>3 Terms and definitions .....</b>	<b>1</b>
<b>4 Dimensions .....</b>	<b>1</b>
<b>5 Application of the connector .....</b>	<b>1</b>
<b>5.1 Connector positions and free space .....</b>	<b>1</b>
<b>5.2 Contact allocation and designation .....</b>	<b>1</b>
<b>5.3 Terminals .....</b>	<b>2</b>
<b>5.4 Connecting cable .....</b>	<b>2</b>
<b>6 Tests and requirements .....</b>	<b>2</b>
<b>6.1 General .....</b>	<b>2</b>
<b>6.2 Immersion of water .....</b>	<b>2</b>

## Foreword

ISO (the International Organization for Standardization) is a worldwide federation of national standards bodies (ISO member bodies). The work of preparing International Standards is normally carried out through ISO technical committees. Each member body interested in a subject for which a technical committee has been established has the right to be represented on that committee. International organizations, governmental and non-governmental, in liaison with ISO, also take part in the work. ISO collaborates closely with the International Electrotechnical Commission (IEC) on all matters of electrotechnical standardization.

International Standards are drafted in accordance with the rules given in the ISO/IEC Directives, Part 2.

The main task of technical committees is to prepare International Standards. Draft International Standards adopted by the technical committees are circulated to the member bodies for voting. Publication as an International Standard requires approval by at least 75 % of the member bodies casting a vote.

Attention is drawn to the possibility that some of the elements of this document may be the subject of patent rights. ISO shall not be held responsible for identifying any or all such patent rights.

ISO 11446-2 was prepared by Technical Committee ISO/TC 22, *Road vehicles*, Subcommittee SC 3, *Electrical and electronic equipment*.

This first edition of ISO 11446-1 cancels and replaces the third edition of ISO 11446:2004, which has been technically revised and divided into two parts, ISO 11446-1 for vehicles *not* intended to cross water fords and ISO 11446-2 for vehicles intended to cross water fords.

ISO 11446 consists of the following parts, under the general title *Road vehicles — Connectors for the electrical connection of towing and towed vehicles*:

- *Part 1: 13-pole connectors for vehicles with 12 V nominal supply voltage not intended to cross water fords*
- *Part 2: 13-pole connectors for vehicles with 12 V nominal supply voltage intended to cross water fords*

iv

# Road vehicles — Connectors for the electrical connection of towing and towed vehicles —

## Part 2: 13-pole connectors for vehicles with 12 V nominal supply voltage intended to cross water fords

### 1 Scope

This part of ISO 11446 specifies the dimensional characteristics of, and contact allocation and tests and requirements for, 13-pole connectors for the electrical connection of towing and towed vehicles with 12 V nominal supply voltage and intended to cross water fords. It specifies a park socket for receiving and storing the plug when it is disconnected.

### 2 Normative references

The following referenced documents are indispensable for the application of this document. For dated references, only the edition cited applies. For undated references, the latest edition of the referenced document (including any amendments) applies.

ISO 1103, *Road vehicles — Coupling balls for caravans and light trailers — Dimensions*

ISO 4091, *Road vehicles — Connectors for the electrical connection of towing and towed vehicles — Definitions, tests and requirements*

ISO 4141 (all parts), *Road vehicles — Multi-core connecting cables*

ISO 11446-1, *Road vehicles — Connectors for the electrical connection of towing and towed vehicles — Part 1: 13-pole connectors for vehicles with 12 V nominal supply voltage not intended to cross water fords*

### 3 Terms and definitions

For the purposes of this document, the terms and definitions given in ISO 4091 apply.

### 4 Dimensions

The dimensions of the plug, the socket and the park socket shall be as specified in ISO 11446-1. Details not specified are at the manufacturer's discretion. The contacts shall be floating and shall align to the datum position when plug and socket are engaged.

### 5 Application of the connector

#### 5.1 Connector positions and free space

The positions of, and free space around, the connectors shall comply with ISO 1103 and ISO 11446-1.

#### 5.2 Contact allocation and designation

The contact allocation and contact designation shall be in accordance with ISO 11446-1.

### 5.3 Terminals

The terminals at the rear side of the pins and tubes shall be capable of accepting cables as defined in ISO 11446-1. Terminals accepting cables with different cross-sectional areas shall be as agreed between manufacturer and user.

### 5.4 Connecting cable

The connecting cable shall meet the requirements of the applicable part of ISO 4141.

## 6 Tests and requirements

### 6.1 General

Connectors according to this part of ISO 11446 shall be tested in accordance with ISO 4091. The additional immersion test in 6.2 shall be performed directly after the influence of water tests in ISO 4091. The connectors shall fulfil the requirements of ISO 4091 and the immersion of water test in 6.2.

### 6.2 Immersion of water

#### 6.2.1 Purpose

This test shall ensure the prevention of water ingress into the plug and socket when the vehicle is crossing a water ford.

#### 6.2.2 Test description

Three sockets with the cover closed and three sockets with connected plugs shall be immersed in a water basin as follows:

- A cable of  $1\ 000\ \text{mm} \pm 100\ \text{mm}$  length shall be attached to the test samples for each test. The open end of the cable shall be outside of the water basin during the test.
- To mount the test sample, use an L-shaped support with an overall width the same as the width of the socket mounting area. The support shall not be deformed when used for the test and shall be able to accept the socket mounting to perform the test as required.
- Mount the test sample to the support according to Figures 1 and 2 and in such a way that the complete mounting surface of the socket rests upon the support and that the support does not protrude from the socket mounting surface for more than 20 mm.
- The test sample shall be preconditioned for 30 min at a temperature of  $40\ ^\circ\text{C} \pm 2\ ^\circ\text{C}$  before immersion. Immersion shall be started within 60 s after the end of preconditioning.
- Use a basin filled with a minimum 50 l of water with a water temperature of  $15\ ^\circ\text{C} \pm 3\ ^\circ\text{C}$ . Immerse the test sample in the basin at a water depth of  $300\ \text{mm} \pm 10\ \text{mm}$  as follows:
  - With the closed cover facing upwards, vertically immerse the support with the test sample into the water filled basin to the test depth according to Figure 1 and with a speed of  $1,38\ \text{m/s} \pm 0,14\ \text{m/s}$ . If the plug is inserted, the test sample shall be immersed in the same direction.
  - Rest at maximum depth for an exposure time of  $20\ \text{min} \pm 1\ \text{min}$ .
  - Remove support with test sample from the water basin.

A 5 A current passing through the cable and across the conductors may be used during the test to detect ingress of water by flashover. In this case, automatically stop the test.

6.2.3 Requirement

Water shall not penetrate into the connector. Check the fulfilment of this requirement. After this requirement is fulfilled, the test samples shall fulfil the requirements of the influence of water tests of ISO 4091.

Dimensions in millimetres

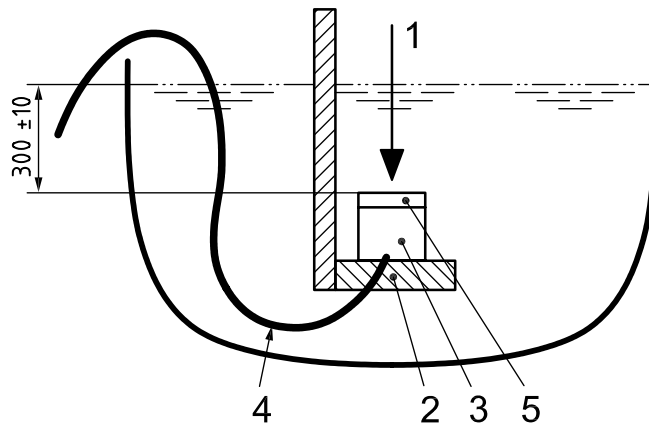

Key

- 1 vertical immersion path
- 2 support
- 3 socket
- 4 attached cable
- 5 closed socket cover

Figure 1 — Immersion of water test with socket in water basin

Dimensions in millimetres

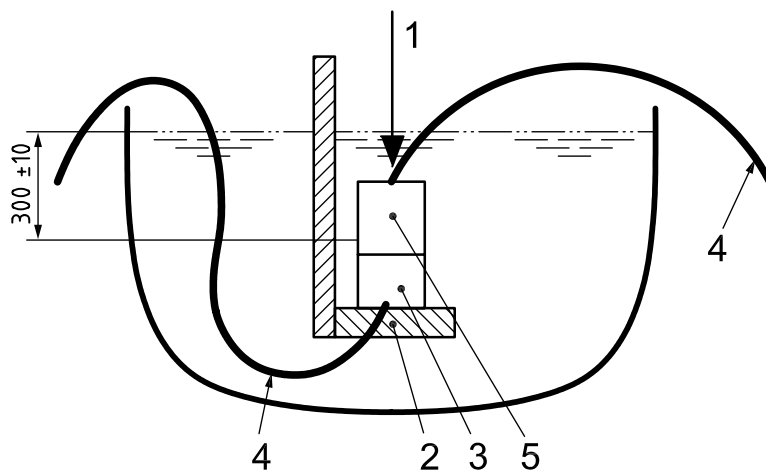

Key

- 1 vertical immersion path
- 2 support
- 3 socket
- 4 attached cable
- 5 plug

Figure 2 — Fording test with plug and socket in water basin

11446-2:2012(E)

---

---

**ICS 43.040.10**

Price based on 3 pages