

---

---

**Gas cylinders — High pressure  
cylinders for the on-board storage of  
natural gas as a fuel for automotive  
vehicles**

*Bouteilles à gaz — Bouteilles haute pression pour le stockage de gaz naturel utilisé comme carburant à bord des véhicules automobiles*





**COPYRIGHT PROTECTED DOCUMENT**

© ISO 2013

All rights reserved. Unless otherwise specified, no part of this publication may be reproduced or utilized otherwise in any form or by any means, electronic or mechanical, including photocopying, or posting on the internet or an intranet, without prior written permission. Permission can be requested from either ISO at the address below or ISO's member body in the country of the requester.

ISO copyright office  
Case postale 56 • CH-1211 Geneva 20  
Tel. + 41 22 749 01 11  
Fax + 41 22 749 09 47  
E-mail [copyright@iso.org](mailto:copyright@iso.org)  
Web [www.iso.org](http://www.iso.org)

Published in Switzerland

# Contents

	Page
<b>Foreword</b> .....	<b>v</b>
<b>Introduction</b> .....	<b>vi</b>
<b>1 Scope</b> .....	<b>1</b>
<b>2 Normative references</b> .....	<b>1</b>
<b>3 Terms and definitions</b> .....	<b>2</b>
<b>4 Service conditions</b> .....	<b>4</b>
4.1 General.....	4
4.2 Maximum pressures.....	4
4.3 Design number of filling cycles.....	4
4.4 Temperature range.....	4
4.5 Gas composition.....	5
4.6 External surfaces.....	5
<b>5 Inspection and testing</b> .....	<b>6</b>
<b>6 Type approval procedure</b> .....	<b>6</b>
6.1 General.....	6
6.2 Type approval.....	6
6.3 Statement of service.....	7
6.4 Design data.....	7
6.5 Manufacturing data.....	8
6.6 Fracture performance and non-destructive examination (NDE) defect size.....	8
6.7 Specification sheet.....	8
6.8 Additional supporting data.....	8
6.9 Type approval certificate.....	8
<b>7 Requirements for type 1 metal cylinders</b> .....	<b>8</b>
7.1 General.....	8
7.2 Materials.....	9
7.3 Design Requirements.....	9
7.4 Construction and workmanship.....	10
7.5 Prototype testing procedure.....	11
7.6 Batch tests.....	13
7.7 Tests on every cylinder.....	15
7.8 Batch acceptance certificate.....	15
7.9 Failure to meet test requirements.....	15
<b>8 Requirements for type 2 hoop-wrapped cylinders</b> .....	<b>16</b>
8.1 General.....	16
8.2 Materials.....	16
8.3 Design requirements.....	17
8.4 Construction and workmanship.....	18
8.5 Prototype testing procedure.....	20
8.6 Batch tests on liners and cylinders.....	22
8.7 Tests on every liner and cylinder.....	25
8.8 Batch acceptance certificate.....	26
8.9 Failure to meet test requirements.....	26
<b>9 Requirements for type 3 fully-wrapped cylinders</b> .....	<b>27</b>
9.1 General.....	27
9.2 Materials.....	27
9.3 Design requirements.....	28
9.4 Construction and workmanship.....	29
9.5 Prototype testing procedure.....	31
9.6 Batch tests on liners and cylinders.....	35
9.7 Tests on every liner and cylinder.....	36

9.8	Batch acceptance certificate.....	37
9.9	Failure to meet test requirements.....	37
<b>10</b>	<b>Requirements for type 4 fully-wrapped composite cylinders.....</b>	<b>38</b>
10.1	General.....	38
10.2	Materials.....	38
10.3	Design requirements.....	38
10.4	Construction and workmanship.....	39
10.5	Prototype testing procedure.....	40
10.6	Batch tests.....	47
10.7	Tests on every cylinder.....	48
10.8	Batch acceptance certificate.....	48
10.9	Failure to meet test requirements.....	49
<b>11</b>	<b>Marking.....</b>	<b>49</b>
<b>12</b>	<b>Preparation for dispatch.....</b>	<b>50</b>
<b>Annex A</b>	<b>(normative) Test methods and criteria.....</b>	<b>51</b>
<b>Annex B</b>	<b>(normative) Ultrasonic examination.....</b>	<b>60</b>
<b>Annex C</b>	<b>(informative) Non-destructive examination (NDE) defect size by flawed cylinder cycling.....</b>	<b>64</b>
<b>Annex D</b>	<b>(informative) Report forms.....</b>	<b>65</b>
<b>Annex E</b>	<b>(informative) Standard working pressures.....</b>	<b>68</b>
<b>Annex F</b>	<b>(informative) Verification of stress ratios using strain gauges.....</b>	<b>69</b>
<b>Annex G</b>	<b>(informative) Manufacturer's instructions for handling, use and inspection of cylinders.....</b>	<b>70</b>

## Foreword

ISO (the International Organization for Standardization) is a worldwide federation of national standards bodies (ISO member bodies). The work of preparing International Standards is normally carried out through ISO technical committees. Each member body interested in a subject for which a technical committee has been established has the right to be represented on that committee. International organizations, governmental and non-governmental, in liaison with ISO, also take part in the work. ISO collaborates closely with the International Electrotechnical Commission (IEC) on all matters of electrotechnical standardization.

International Standards are drafted in accordance with the rules given in the ISO/IEC Directives, Part 2.

The main task of technical committees is to prepare International Standards. Draft International Standards adopted by the technical committees are circulated to the member bodies for voting. Publication as an International Standard requires approval by at least 75 % of the member bodies casting a vote.

Attention is drawn to the possibility that some of the elements of this document may be the subject of patent rights. ISO shall not be held responsible for identifying any or all such patent rights.

ISO 11439 was prepared by Technical Committee ISO/TC 58, *Gas cylinders*, Subcommittee SC 3, *Cylinder design*.

This second edition cancels and replaces the first edition (ISO 11439:2000), which has been technically revised. In addition to editorial improvements, the principal technical difference between the first and second editions is the clarification and alteration of the “Change of Design” requirements for the various cylinder types.

## **Introduction**

Cylinders for the on-board storage of fuel for natural gas vehicle service are required to be light-weight, at the same time maintaining or improving on the level of safety currently existing for other pressure vessels.

Owners or users of cylinders designed to this International Standard should note that the cylinders are designed to operate safely if used in accordance with specified service conditions for a specified finite service life only. The expiry date is marked on each cylinder and it is the responsibility of owners and users to ensure that cylinders are not used after that date, and that they are inspected in accordance with the manufacturer's instructions.

Users of this International Standard are encouraged to consider the environmental impacts associated with performing certain tests.

# Gas cylinders — High pressure cylinders for the on-board storage of natural gas as a fuel for automotive vehicles

## 1 Scope

This International Standard specifies minimum requirements for light-weight refillable gas cylinders intended only for the on-board storage of high pressure compressed natural gas as a fuel for automotive vehicles to which the cylinders are to be fixed. The service conditions do not cover external loadings that can arise from vehicle collisions, etc.

This International Standard covers cylinders of any seamless steel, seamless aluminium alloy or non-metallic material construction, using any design or method of manufacture suitable for the specified service conditions. This International Standard does not cover cylinders of stainless steel. Although this standard uses 200 bar as a reference working pressure, other working pressures can be used.

Cylinders covered by this International Standard are designated Type 1, Type 2, Type 3 and Type 4.

## 2 Normative references

The following documents, in whole or in part, are normatively referenced in this document and are indispensable for its application. For dated references, only the edition cited applies. For undated references, the latest edition of the referenced document (including any amendments) applies.

ISO 148-1, *Metallic materials — Charpy pendulum impact test — Part 1: Test method*

ISO 306, *Plastics — Thermoplastic materials — Determination of Vicat softening temperature (VST)*

ISO 527-2, *Plastics — Determination of tensile properties — Part 2: Test conditions for moulding and extrusion plastics*

ISO 2808, *Paints and varnishes — Determination of film thickness*

ISO 6506-1, *Metallic materials — Brinell hardness test — Part 1: Test method*

ISO 6892-1, *Metallic materials — Tensile testing — Part 1: Method of test at room temperature*

ISO 7866, *Gas cylinders — Refillable seamless aluminium alloy gas cylinders — Design, construction and testing*

ISO 9227, *Corrosion tests in artificial atmospheres — Salt spray tests*

ISO 9712, *Non-destructive testing — Qualification and certification of NDT personnel*

ISO 9809-1, *Gas cylinders — Refillable seamless steel gas cylinders — Design, construction and testing — Part 1: Quenched and tempered steel cylinders with tensile strength less than 1 100 MPa*

ISO 9809-2, *Gas cylinders — Refillable seamless steel gas cylinders — Design, construction and testing — Part 2: Quenched and tempered steel cylinders with tensile strength greater than or equal to 1 100 MPa*

ISO 9809-3, *Gas cylinders — Refillable seamless steel gas cylinders — Design, construction and testing — Part 3: Normalized steel cylinders*

ISO 14130, *Fibre-reinforced plastic composites — Determination of apparent interlaminar shear strength by short-beam method*

ISO 15403-1, *Natural gas — Natural gas for use as a compressed fuel for vehicles — Part 1: Designation of the quality*

## ISO 11439:2013(E)

ISO/TR 15403-2, *Natural gas — Natural gas for use as a compressed fuel for vehicles — Part 2: Specification of the quality*

ISO 15500-13, *Road vehicles — Compressed natural gas (CNG) fuel system components — Part 13: Pressure relief device (PRD)*

ASTM D522-93a, *Standard Test Methods for Mandrel Bend Test of Attached Organic Coatings*

ASTM D1308-87, *Standard Test Method for Effect of Household Chemicals on Clear and Pigmented Organic Finishes*

ASTM D2794-93, *Standard Test Method for Resistance of Organic Coatings to the Effects of Rapid Deformation (Impact)*

ASTM D3170-87, *Standard Test Method for Chipping Resistance of Coatings*

ASTM D3359, *Standard Test Methods for Measuring Adhesion by Tape Test*

ASTM D3418, *Standard Test Method for Transition Temperatures of Polymers by Differential Scanning Calorimetry*

ASTM G154:2006<sup>1)</sup>, *Standard Practice for Operating Fluorescent Light Apparatus for UV Exposure of Nonmetallic Materials*

NACE/TM 0177-96, *Laboratory Testing of Metals for Resistance to Sulfide Stress Cracking and Stress Corrosion Cracking in H<sub>2</sub>S Environments*

### 3 Terms and definitions

For the purposes of this document, the following terms and definitions apply.

**3.1 authorized inspection body**  
authorized inspection body, approved or recognized by the regulatory authority of the user country, for the supervision of construction and testing of cylinders used for the on-board storage of natural gas

**3.2 autofrettage**  
pressure application procedure used in manufacturing composite cylinders with metal liners, which strains the liner past its yield point sufficient to cause permanent plastic deformation

**3.3 autofrettage pressure**  
pressure within the overwrapped cylinder at which the required distribution of stresses between the liner and the overwrap is established

**3.4 batch – composite cylinders**  
group of not more than 200 cylinders plus cylinders for destructive testing, or if greater, one shift of successive production of cylinders, successively produced from qualified liners having the same size, design, specified materials of construction and process of manufacture

**3.5 batch – metal cylinders/liners**  
group of not more than 200 cylinders/liners plus cylinders/liners for destructive testing, or if greater, one shift of successive production of metal cylinders/liners, successively produced having the same nominal diameter, wall thickness, design, specified material of construction, material cast, process of manufacture, equipment for manufacture and heat treatment, and conditions of time, temperature and atmosphere during heat treatment

---

1) Most recent version is ASTM G154-12a, 2012.



**3.6****batch – non-metallic liners**

group of not more than 200 liners plus liners for destructive testing, or if greater, one shift of successive production of non-metallic liners, successively produced having the same nominal diameter, wall thickness, design, specified material of construction and process of manufacture

**3.7****burst pressure**

highest pressure reached in a cylinder during a burst test

**3.8****composite cylinder**

cylinder made of resin-impregnated continuous filament wound over a metallic or non-metallic liner

**3.9****destroyed**

cylinder in a state of alteration which makes it physically unusable for its purpose

**3.10****finished cylinders**

completed cylinders which are ready for use, complete with identification marks and external coating including integral insulation and/or protection as specified by the manufacturer on the design drawing for the cylinder

**3.11****liner**

inner portion of the composite cylinder, comprising of a metallic or non-metallic vessel

**3.12****manufacturer**

person or organization responsible for the design, fabrication and testing of the cylinders

**3.13****overwrap**

reinforcement system of filament and resin applied over the liner

**3.14****pre-stress**

process of applying autofrettage or controlled tension winding

**3.15****service life**

life, in years, during which the cylinders can be used in accordance with the standard service conditions

**3.16****settled pressure**

gas pressure when a given settled temperature is reached

**3.17****settled temperature**

uniform gas temperature in the cylinder after the dissipation of any heat caused by filling

**3.18****test pressure**

required pressure applied during a pressure test

**3.19****type 1 design**

an all metal cylinder

**3.20**

**type 2 design**

a hoop wrapped cylinder with a load sharing metal liner and composite reinforcement on the cylindrical part only

**3.21**

**type 3 design**

a fully wrapped cylinder with a load sharing metal liner and composite reinforcement on both the cylindrical part and dome ends

**3.22**

**type 4 design**

a fully wrapped cylinder with a non-load sharing liner and composite reinforcement on both the cylindrical part and dome ends

**3.23**

**working pressure**

settled pressure of a fully filled cylinder at a uniform temperature of 15 °C

## **4 Service conditions**

### **4.1 General**

#### **4.1.1 Standard service conditions**

The standard service conditions specified in this clause are provided as the basis for the design, manufacture, inspection, testing and approval of cylinders that are to be mounted permanently on vehicles and used to store natural gas at ambient temperatures for use as a fuel on the vehicles.

#### **4.1.2 Service life**

The service life for which cylinders are safe shall be specified by the cylinder manufacturer on the basis of use under service conditions specified herein. The maximum service life shall be 20 years.

### **4.2 Maximum pressures**

This International Standard is based upon a working pressure of 200 bar settled at 15 °C for natural gas as a fuel with a maximum filling pressure of 260 bar. Other working pressures may be accommodated by adjusting the pressure by the appropriate factor (ratio); e.g. a 240 bar working pressure system will require pressures to be multiplied by 1,20. See also [Annex E](#).

Except where pressures have been adjusted in this way, the cylinder shall be designed to be suitable for:

- a) a pressure of 200 bar at a settled temperature of 15 °C;
- b) a maximum pressure shall not exceed 260 bar, regardless of filling conditions or temperature.

### **4.3 Design number of filling cycles**

Cylinders shall be designed to be filled up to 1 000 times per year of service.

### **4.4 Temperature range**

#### **4.4.1 Settled gas temperature**

Settled temperature of gas in cylinders, which may vary from a minimum of -40 °C to a maximum of +65 °C.

#### 4.4.2 Cylinder temperatures

Cylinders shall be designed for service conditions involving temperatures of between  $-40\text{ }^{\circ}\text{C}$  and  $+82\text{ }^{\circ}\text{C}$ . Cylinder material temperatures over  $+65\text{ }^{\circ}\text{C}$  are expected to be sufficiently local, or of short enough duration, that the temperature of gas in the cylinder never exceeds  $+65\text{ }^{\circ}\text{C}$ , except under the conditions of [4.4.3](#).

#### 4.4.3 Transient temperatures

Developed gas temperatures in the cylinders during filling and discharge may vary beyond the limits of [4.4.1](#).

### 4.5 Gas composition

#### 4.5.1 General

Cylinders shall be designed to tolerate being filled with natural gas meeting the specification of ISO 15403-1 and ISO/TR 15403-2, and either of dry gas or wet gas as described in [4.5.2](#) or [4.5.3](#), respectively. Methanol and/or glycol shall not be deliberately added to the natural gas.

NOTE Where it is suspected that wet-gas conditions may exist, it has been found that a minimum of 1 mg of compressor oil per kg of gas has prevented the corrosion of steel cylinders.

#### 4.5.2 Dry gas

Water vapour shall be limited to less than  $32\text{ mg/m}^3$  (i.e. a pressure dewpoint of  $-9\text{ }^{\circ}\text{C}$  at 200 bar). Constituent maximum limits shall be:

Hydrogen sulfide and other soluble sulfides	23 mg/m <sup>3</sup>
Oxygen	1 % (volume fraction)
Hydrogen, when cylinders are manufactured from a steel with an ultimate tensile strength exceeding 950 MPa	2 % (volume fraction)

#### 4.5.3 Wet gas

For gas that has a higher water content than that of dry gas, constituent limits shall be:

Hydrogen sulfide and other soluble sulfides	23 mg/m <sup>3</sup> maximum
Oxygen	1 % (volume fraction) maximum
Carbon dioxide	3 % (volume fraction) maximum
Hydrogen	0,1 % (volume fraction) maximum
Compressor oil	1 mg/kg natural gas minimum (see Note <a href="#">4.5.1</a> )

### 4.6 External surfaces

It is not necessary for cylinders to be designed for continuous exposure to mechanical or chemical attack (e.g. leakage from cargo that may be carried on vehicles or severe abrasion damage from road conditions). However, cylinder external surfaces shall be designed to withstand inadvertent exposure to mechanical or chemical attack consistent with their installation being carried out in accordance with the instructions to be provided with the cylinder.

Mechanical or chemical attack may result from environments such as:

- a) water, either by intermittent immersion or road spray;

- b) salt, due to the operation of the vehicle near the ocean or where ice-melting salt is used;
- c) ultraviolet radiation from sunlight;
- d) impact of gravel;
- e) solvents, acids and alkalis, fertilizers;
- f) automotive fluids, including petrol, hydraulic fluids, battery acid, glycol and oils;
- g) exhaust gases.

## **5 Inspection and testing**

Evaluation of conformity can be carried out in accordance with the relevant regulations recognized by the country(ies) where the cylinders are intended to be used.

To ensure that cylinders are in conformance to this International Standard, they shall be subject to inspection and testing in accordance with [Clauses 7, 8, 9, or 10](#) and [Annex A](#) as appropriate to the construction. This shall be carried out by an authorized inspection body, hereafter referred to as “the Inspector”, recognized in the countries of use. The Inspector shall be competent for inspection of cylinders.

## **6 Type approval procedure**

### **6.1 General**

Type approval consists of two parts:

- a) design approval, comprising submission of information by the manufacturer to the Inspector, as detailed in [6.3](#).
- b) prototype testing, comprising testing carried out under the supervision of the Inspector. The cylinder material, design, manufacture and examination shall be proved to be adequate for their intended service by meeting the requirements of the prototype tests specified in [7.5, 8.5, 9.5 or 10.5](#), and [Annex A](#), as appropriate for the particular cylinder design.

The test data shall also document the dimensions, wall thicknesses and weights of each of the test cylinders.

### **6.2 Type approval**

Cylinder designs shall be approved by the Inspector. Information shall be submitted by the manufacturer with a request to the Inspector for approval, and shall include:

- a) statement of service, in accordance with [6.3](#);
- b) design data, in accordance with [6.4](#);
- c) manufacturing data, in accordance with [6.5](#);
- d) fracture performance and NDE defect size, in accordance with [6.6](#);
- e) specification sheet, in accordance with [6.7](#);
- f) additional supporting data, in accordance with [6.8](#).

### 6.3 Statement of service

The purpose of the statement of service is to guide users and installers of cylinders as well as to inform the Inspector. The statement of service shall include:

- a) a statement that the cylinder design is suitable for use in the service conditions defined in [Clause 4](#) for the service life of the cylinder;
- b) a statement of the service life;
- c) the minimum periodic inspection requirements;
- d) a specification for the pressure relief devices, and insulation if provided;
- e) a specification for the support methods, protective coatings and any other items required but not provided;
- f) a description of the cylinder design;
- g) any other information and instructions necessary to ensure the safe use and inspection of the cylinder.

### 6.4 Design data

#### 6.4.1 Drawings

Drawings shall include, as a minimum:

- a) title, manufacturer, reference number, date of issue, and revision numbers with dates of issue if applicable;
- b) reference to this International Standard and the cylinder type;
- c) all cylinder dimensions complete with tolerances, including details of end closure shapes, openings, and neck threads;
- d) water capacity and mass (including any permanent attachments), complete with tolerance, of cylinders;
- e) material specifications, mechanical properties (including tolerances where applicable) and, for metal cylinders or metal liners, the specified hardness range;
- f) other data such as, working pressure, autofrettage pressure, test pressure, minimum design burst pressure, design life;
- g) details of the fire protection system and of any exterior protective coating.

#### 6.4.2 Stress analysis report

A finite element stress analysis or other stress analysis shall be carried out. A table summarizing the calculated stresses shall be provided.

#### 6.4.3 Material property data

A description of the materials and tolerances of the material properties used in the design shall be provided. Test data shall also be presented characterizing the mechanical properties and the suitability of the materials for service under the conditions specified in [Clause 4](#).

#### 6.4.4 Fire protection

The arrangement of pressure relief devices, and insulation if provided, that will protect the cylinder from sudden rupture when exposed to the fire conditions in A.15 shall be specified. Test data shall substantiate the effectiveness of the specified fire protection system.

NOTE A manufacturer may specify alternative PRD locations for specific vehicle installations.

#### 6.5 Manufacturing data

Details of fabrication processes, non-destructive examinations, production tests and batch tests shall be provided. Production processes such as heat treatment, end forming, resin-mix ratio, filament tension and speed for controlled tension winding, curing times and temperatures, and autofrettage procedures shall be specified.

Surface finish, thread details, acceptance criteria for ultrasonic examination (or equivalent), and maximum lot sizes for batch tests shall also be specified.

#### 6.6 Fracture performance and non-destructive examination (NDE) defect size

The manufacturer shall specify the maximum defect size for non-destructive examination that will ensure leak before break (LBB) fracture performance, and will prevent failure by leakage or rupture of the cylinder during its service life. The maximum defect size shall be established by a method suitable to the design.

NOTE An example of a suitable method is given in [Annex C](#).

#### 6.7 Specification sheet

A summary of the documents providing the information required in [6.2](#) shall be listed on a specification sheet for each cylinder design. The title, reference number, revision numbers and dates of original issue and version issues of each document shall be given. All documents shall be signed or initialled by the issuer.

#### 6.8 Additional supporting data

Additional data that would support the application may be provided.

#### 6.9 Type approval certificate

If the results of the type approval according to [6.1](#) and the prototype testing according to [7.5](#), [8.5](#), [9.5](#) or [10.5](#), and [Annex A](#), as appropriate to the particular cylinder design, are satisfactory, the Inspector shall issue a test type approval certificate.

NOTE An example of a type approval certificate is given in [Annex D](#).

### 7 Requirements for type 1 metal cylinders

#### 7.1 General

This International Standard does not provide design formulae, nor list permissible stresses or strains, but requires the adequacy of the design to be established by appropriate calculations and demonstrated by testing to show that cylinders shall pass the materials, design qualification, production and batch tests specified.

The design shall ensure a “leak-before-break” failure mode during normal service.

## 7.2 Materials

### 7.2.1 General requirements

Materials used shall be suitable for the service conditions specified in [Clause 4](#). The design shall not have incompatible materials in contact with each other.

### 7.2.2 Controls on chemical composition

#### 7.2.2.1 Steel

Steels shall be aluminium- and/or silicon-killed. The chemical composition of all steels shall be declared and defined at least by:

- a) the carbon, manganese, aluminium and silicon contents in all cases;
- b) the chromium, nickel, molybdenum, boron and vanadium contents, and that of any other alloying elements intentionally added.

The sulfur and phosphorus content in the cast analysis shall not exceed the values given in [Table 1](#).

**Table 1 — Maximum sulfur and phosphorus limits**

sulfur	0,010 % by mass
phosphorus	0,020 % by mass
sulfur + phosphorus	0,025 % by mass

#### 7.2.2.2 Aluminium

Aluminium alloys may be used to produce cylinders provided that they meet all requirements of this International Standard and have maximum lead and bismuth contents not exceeding 0,003 %.

NOTE A list of registered alloys is maintained by the Aluminium Association Inc.<sup>2)</sup> and can be found under the “International Registration Records”, entitled “International Alloy Designations and Chemical Composition Limits for Wrought Aluminium and Wrought Aluminium Alloys”.

## 7.3 Design Requirements

### 7.3.1 Test pressure

The minimum test pressure used in manufacture shall be 1,5 times working pressure.

### 7.3.2 Burst pressure

The minimum burst pressure shall be not less than 2,25 times working pressure.

### 7.3.3 Stress analysis

The stresses in the cylinder shall be calculated for the working pressure, test pressure and design burst pressure. The calculations shall use suitable analysis to establish stress distributions to justify the minimum design wall thicknesses.

<sup>2)</sup> Aluminum Association Inc., 900 19th Street N.W., Washington D.C., 20006-2168, USA.

### 7.3.4 Maximum defect size

The maximum defect size at any location in the metal cylinder such that the cylinder meets pressure cycling and LBB requirements, shall be specified.

The allowable defect size for NDE shall be determined by an appropriate method, e.g. as described in [Annex C](#).

### 7.3.5 Openings

The centre line of openings shall coincide with the longitudinal axis of the cylinder.

### 7.3.6 Fire protection

The cylinder design shall be protected with pressure relief devices. The cylinder, its materials, pressure relief devices (PRD) and any added insulation or protective material shall be designed collectively to ensure adequate safety during fire conditions in the test specified in A.15. A manufacturer may specify alternative PRD locations for specific vehicle installations in order to optimize safety considerations.

Pressure relief devices shall conform to ISO 15500-13.

### 7.3.7 Attachments

When a neck ring, foot ring or an attachment for support is provided, it shall be of material compatible with that of the cylinder and shall be securely attached by a method other than welding, brazing or soldering.

## 7.4 Construction and workmanship

### 7.4.1 End closure

Each cylinder shall be examined for thickness and surface finish before end forming operations are carried out. The base ends of aluminium cylinders shall not be sealed by a forming process. The base ends of steel cylinders that have been closed by forming shall be NDE inspected or equivalent after closure. Metal shall not be added in the process of closure at the ends.

### 7.4.2 Heat treatment

After end forming the cylinders shall be heat treated to the hardness range specified for the design. Localized heat treatment shall not be used.

### 7.4.3 Neck threads

Threads shall be clean cut, even, without surface discontinuities, to gauge and conform to International Standards.

### 7.4.4 Exterior environmental protection

Exterior protection may be provided. Examples of exterior protection methods are:

- a) a surface finish giving adequate protection (e.g. metal sprayed on to aluminium, anodizing); or
- b) a protective coating (e.g. organic coating, paint); if exterior coating is part of the design as specified by the manufacturer the requirements of A.9 shall be met.

Any coatings applied to cylinders shall be such that the application process does not adversely affect the mechanical properties of the cylinder. The coating shall be designed to facilitate subsequent in-service inspection and the manufacturer shall provide guidance on coating treatment during such inspection in order to ensure the continued integrity of the cylinder.



### 7.4.5 Traceability

Materials of construction affecting cylinder performance, as determined by the manufacturer, shall be traceable to the extent required to recall cylinders, if necessary.

## 7.5 Prototype testing procedure

### 7.5.1 General requirements

Prototype testing shall be conducted on each new design, on finished cylinders that are representative of normal production and complete with permanent identification marks. The test cylinders shall be selected and the prototype tests specified in 7.5.2 (and detailed in [Annex A](#)) verified by the Inspector. If more cylinders are subjected to the tests than are required by this International Standard, all results shall be documented.

### 7.5.2 Prototype tests

#### 7.5.2.1 Tests required

The Inspector shall select the necessary cylinders for testing and verify:

- a) the tests specified in 7.5.2.2 or 7.5.2.3 (material tests) on one cylinder;
- b) the test specified in 7.5.2.4 (hydrostatic pressure burst test) on three cylinders;
- c) the test specified in 7.5.2.5 (ambient temperature pressure cycling test) on two cylinders;
- d) the test specified in 7.5.2.6 (LBB test) on three cylinders;
- e) the test specified in 7.5.2.7 (bonfire test) on one or two cylinders, as appropriate;
- f) the test specified in 7.5.2.8 (penetration test) on one cylinder.

#### 7.5.2.2 Material tests for steel cylinders

- a) Tensile test

Steel from a finished cylinder shall meet the requirements of the tensile test in A.1.

- b) Impact test

Steel from a finished cylinder shall meet the requirements of the impact test in A.2.

- c) Sulfide stress cracking resistance test

If the upper limit of the specified tensile strength for the steel exceeds 950 MPa, the steel from a finished cylinder shall meet the requirements of the sulfide stress cracking resistance test in A.3.

#### 7.5.2.3 Material tests for aluminium alloy cylinders

- a) Tensile test

Aluminium alloy from a finished cylinder shall meet the requirements of the tensile test in A.1.

- b) Corrosion tests

Aluminium alloy from a finished cylinder shall meet the requirements of the corrosion tests in A.4.

- c) Sustained load cracking tests

Aluminium alloy from a finished cylinder shall meet the requirements of the sustained load cracking tests in A.5.

### 7.5.2.4 Hydrostatic pressure burst test

Three representative cylinders shall be hydrostatically pressurized to failure in accordance with A.12. The cylinder burst pressures shall exceed the minimum burst pressure calculated by the stress analysis for the design, and shall be at least 2,25 times working pressure. The fracture shall initiate in the cylindrical part of the cylinder, and the cylinder shall remain in one piece.

### 7.5.2.5 Ambient temperature pressure cycling test

Two cylinders shall be pressure cycled at ambient temperature in accordance with A.13. The cylinders shall not fail before reaching the specified service life in years multiplied by 1 000 cycles. Cylinders that complete the test shall be destroyed.

### 7.5.2.6 Leak-before-break (LBB) test

Three cylinders shall be tested in accordance with A.6.

### 7.5.2.7 Bonfire test

One or two cylinders, as appropriate, shall be tested in accordance with A.15.

### 7.5.2.8 Penetration test

One cylinder shall be tested in accordance with A.16.

### 7.5.3 Change of design

A design change is a dimensional change not attributable to normal manufacturing tolerances, or any change in the selection of structural materials. Design changes may be qualified through a reduced test programme. Changes of design specified in [Table 2](#) shall require only the prototype testing as specified in the table.

Table 2 — Change of design for type 1 cylinders

Design change	Type of test				
	Hydrostatic burst	Pressure cycling at ambient temperature	LBB	Bonfire	Penetration
	Clause				
	A.12	A.13	A.6	A.15	A.16
Metallic cylinder material <sup>d</sup>	X	X	X	X	X
Diameter change ≤ 20 %	X	X			
Diameter change > 20 %	X	X	X	X	X
Length change ≤ 50 %	X			X <sup>a</sup>	
Length change > 50 %	X	X		X <sup>a</sup>	
Working pressure change ≤ 20 % <sup>b</sup>	X	X			
Dome shape	X	X	X <sup>c</sup>		
Opening size	X	X			
Pressure relief device				X	
<p><sup>a</sup> Test only required when length increases.</p> <p><sup>b</sup> Only when thickness change proportional to diameter and/or pressure change.</p> <p><sup>c</sup> Only required for non-ISO 9809-1 designs.</p> <p><sup>d</sup> Materials tests are also required.</p>					

## 7.6 Batch tests

### 7.6.1 General requirements

Batch testing shall be conducted on finished cylinders that are representative of normal production and are complete with permanent identification marks. The cylinders required for testing shall be randomly selected from each batch. If more cylinders are subjected to the tests than are required by this International Standard, all results shall be documented. Heat treated samples shown to be representative of finished cylinders may also be used.

Cylinders qualified in accordance with ISO 9809-1, ISO 9809-2, ISO 9809-3 or ISO 7866 are not required to perform the pressure cycling test described in [7.6.2.2](#).

### 7.6.2 Required tests

#### 7.6.2.1 Batch tests

Tests shall be carried out on each batch of cylinders:

- a) on one cylinder, one hydrostatic pressure burst test in accordance with A.12.
- b) on a further cylinder, or a heat treated witness sample representative of a finished cylinder:
  - 1) a check of the critical dimensions against the design (see [6.4.1](#));

- 2) one tensile test in accordance with A.1; the test results shall satisfy the requirements of the design (see [6.4.1](#));
- 3) for steel cylinders, three impact tests in accordance with A.2; the test results shall satisfy the requirements specified in A.2;
- 4) for steel cylinders with a specified tensile strength exceeding 1 100 MPa, each new cast of material shall meet the requirements of the sulphide stress cracking test in A.3. A sample of material from each cast may be heat treated and tested by the steel supplier or cylinder manufacturer, provided that the samples have the same strength values specified in the cylinder design.
- 5) when a protective coating is a part of the design, a coating batch test in accordance with A.24. Where the coating fails to meet the requirements of A.24, the batch shall be 100 % inspected to remove cylinders with similar defective coatings. The coating on all defectively coated cylinders may be stripped and recoated. The coating batch test shall then be repeated.

All cylinders represented by a batch test and which fail to meet the specified requirements shall follow the procedures specified in [7.9](#).

#### 7.6.2.2 Pressure cycling test

A pressure cycling test shall be carried out on finished cylinders in accordance with A.13 at a test frequency defined as:

- a) initially, one cylinder from each batch shall be pressure cycled for a total of 1 000 times the specified service life in years, with a minimum 15 000 cycles;
- b) if on 10 sequential production batches of a design family (i.e. similar materials and processes within the definition of a minor design change, see 7.5.3), none of the pressure cycled cylinders in 7.6.2.2a) leaks or ruptures in less than 1 500 cycles multiplied by the specified life in years (minimum 22 500 cycles), the pressure cycle test may be reduced to one cylinder from every five batches of production;
- c) if on 10 sequential production batches of a design family, none of the pressure cycled cylinders in 7.6.2.2a) leaks or ruptures in less than 2 000 cycles multiplied by the specified service life in years (minimum 30 000 cycles), the pressure cycle test may be reduced to one cylinder from every 10 batches of production;
- d) should more than three months have expired since the last pressure cycle test, then a cylinder from the next batch of production shall be pressure cycle tested in order to maintain the reduced frequency of batch testing in 7.6.2.2b) or 7.6.2.2c);
- e) should any reduced frequency pressure cycle test cylinder in 7.6.2.2b) or 7.6.2.2c) fail to meet the required number of pressure cycles (minimum 22 500 or 30 000 pressure cycles, respectively), it shall be necessary to repeat the batch pressure cycle test frequency in 7.6.2.2a) for a minimum of 10 production batches to re-establish the reduced frequency of batch pressure cycle testing in 7.6.2.2b) or 7.6.2.2c).

Should any cylinder in 7.6.2.2a), 7.6.2.2b) or 7.6.2.2c) fail to meet the minimum cycle life requirement of 1 000 cycles multiplied by the specified service life in years (minimum 15 000 cycles), the cause of failure shall be determined and corrected following the procedures in [7.9](#). The pressure cycle test shall then be repeated on an additional three cylinders from that batch. Should any of the three additional cylinders fail to meet the minimum pressure cycling requirement of 1 000 cycles multiplied by the specified service life in years, the batch shall be rejected.

## 7.7 Tests on every cylinder

Production examinations and tests shall be carried out on each cylinder produced in a batch, either during manufacture or after completion, as appropriate:

- a) by NDE in accordance with [Annex B](#) or proven equivalent method to verify that the maximum defect size does not exceed the size specified in the design as determined in accordance with [7.3.4](#). The NDE method shall be capable of detecting the maximum defect size allowed;
- b) to verify that the critical dimensions and mass of the completed cylinders are within design tolerances;
- c) to verify conformance to specified surface finish with special attention to deep drawn surfaces and folds or laps in the neck or shoulder of forged or spun end enclosures or openings;
- d) to verify the permanent identification marks;
- e) by hardness tests of heat treated cylinders in accordance with A.8; the values thus determined shall be in the range specified for the design;
- f) by hydrostatic test of finished cylinders in accordance with A.11. If volumetric expansion test is chosen, the manufacturer shall establish the appropriate limit of permanent expansion for the test pressure used, but in no case shall the permanent expansion exceed 10 % of the total volumetric expansion measured under the test pressure;
- g) by leak testing of cylinders with base ends formed by spinning. Typical testing procedures include the pneumatic leakage test where the bottom end should be clean and free from all moisture on the test pressure side. The inside area of the cylinder bottom surrounding the closure should be subjected to a pressure equal to at least 2/3 times the test pressure of the cylinder for a minimum of 1 min. This area should be not less than 20 mm in diameter around the closure and at least 6 % of the total bottom area. The opposite side should be covered with water or another suitable medium and closely examined for indication of leakage. Cylinders that leak should be rejected. Other test procedures include a low pressure pneumatic test, and a helium leak test.

## 7.8 Batch acceptance certificate

If the results of batch testing according to [7.6](#) and [7.7](#) are satisfactory, the manufacturer and the Inspector shall sign an acceptance certificate.

NOTE An example of an acceptance certificate (referred to as a "Report of Manufacture and Certificate of Conformance") is given in [Annex D](#).

## 7.9 Failure to meet test requirements

In the event of failure to meet test requirements, re-testing or re-heat treatment and re-testing shall be carried out:

- a) if there is evidence of a fault in carrying out a test, or an error of measurement, a further test shall be performed; if the result of this test is satisfactory, the first test shall be ignored;
- b) if the test has been carried out in a satisfactory manner, the cause of test failure shall be identified.

If the failure is considered to be due to the heat treatment applied, the manufacturer may subject all the cylinders implicated by the failure to a further heat treatment, i.e. if the failure is in a test representing the prototype or batch cylinders, test failure shall require re-heat treatment of all the represented cylinders prior to re-testing.

Whenever cylinders are re-heat treated, the minimum guaranteed wall thickness shall be maintained.

Only the relevant prototype or batch tests needed to prove the acceptability of the new batch shall be performed again. If one or more tests prove even partially unsatisfactory, all cylinders of the batch shall be rejected and not placed in service.

If the failure is due to a cause other than the applied heat treatment, all defective cylinders shall be either rejected or repaired by an approved method. Provided that the repaired cylinders pass the test(s) required for the repair, they shall be re-instated as part of the original batch.

## 8 Requirements for type 2 hoop-wrapped cylinders

### 8.1 General

This International Standard does not provide design formulae nor list permissible stresses or strains, but requires the adequacy of the design to be established by appropriate calculations and demonstrated by testing to show that cylinders shall pass the materials, design qualification, production and batch tests specified in this International Standard.

During pressurization, this type of cylinder design exhibits behaviour in which the displacements of the composite overwrap and the metal liner are superimposed.

The design shall ensure a “leak-before-break” failure mode during normal service.

### 8.2 Materials

#### 8.2.1 General requirements

Materials used shall be suitable for the service conditions specified in [Clause 4](#). The design shall ensure that incompatible materials are not used in the construction of the cylinder.

All composite materials shall be stored in accordance with the material manufacturers’ requirements.

#### 8.2.2 Controls on chemical composition

##### 8.2.2.1 Steel

Steels shall be aluminium- and/or silicon-killed. The chemical composition of all steels shall be declared and defined at least by:

- a) the carbon, manganese, aluminium, and silicon contents in all cases;
- b) the chromium, nickel, molybdenum, boron and vanadium contents, and that of any other alloying elements intentionally added.

The sulfur and phosphorus content in the cast analysis shall not exceed the values given in [Table 3](#).

**Table 3 — Maximum sulfur and phosphorus limits**

sulfur	0,010 % by mass
phosphorus	0,020 % by mass
sulfur + phosphorus	0,025 % by mass

##### 8.2.2.2 Aluminium

Aluminium alloys may be used to produce cylinders provided they meet all requirements of this International Standard and have maximum lead and bismuth contents not exceeding 0,003 %.

### 8.2.3 Composite materials

#### 8.2.3.1 Resins

The material for impregnation may be thermosetting or thermoplastic resins. Examples of suitable matrix materials are epoxy, modified epoxy, polyester and vinyl ester thermosetting plastics, and polyethylene and polyamide thermoplastic material.

The glass transition temperature of the resin material shall be determined in accordance with ASTM D3418.

#### 8.2.3.2 Fibres

Structural reinforcing filament material types shall be glass fibre, aramid fibre or carbon fibre. If carbon fibre reinforcement is used, the design shall incorporate means to prevent galvanic corrosion of the metallic components of the cylinder.

The fibre manufacturer shall certify that the fibre material properties conform to the manufacturer's specifications for the fibre.

## 8.3 Design requirements

### 8.3.1 Test pressure

The minimum test pressure used in manufacture shall be 1,5 times working pressure.

### 8.3.2 Burst pressures and fibre stress ratios

The metal liner shall have a minimum burst pressure of 1,3 times working pressure.

The minimum burst pressure shall be not less than the values given in [Table 4](#). Stress ratio is defined as the stress in the fibre at the specified minimum burst pressure divided by the stress in the fibre at working pressure.

The burst ratio is defined as the burst pressure of the cylinder divided by the working pressure.

The stress ratio calculations shall at least take into account:

- a) an analysis method with capability for nonlinear materials (special purpose computer program or finite element analysis program);
- b) correct modelling of the elastic-plastic stress-strain curve for a known liner material;
- c) correct modelling of the mechanical properties of composite materials;
- d) calculations at autofrettage pressure, zero pressure after autofrettage, working pressure, and minimum burst pressure;
- e) account for the pre-stresses from winding tension;
- f) the minimum burst pressure, chosen such that the calculated stress at minimum burst pressure divided by the calculated stress at working pressure meets the stress ratio requirements for the fibre used;
- g) consideration of the load share between the different fibres based on the different elastic moduli of the fibres when analysing cylinders with hybrid reinforcement (two or more different fibres). The stress ratio requirements for each individual fibre type shall be in accordance with the values given in [Table 4](#).

Verification of the stress ratios may also be performed using strain gauges.

NOTE An acceptable method is outlined in [Annex F](#).

**Table 4 — Minimum burst values and stress ratios for type 2 cylinders (with a working pressure of 200 bar)**

Fibre Type	Stress Ratio	Burst Pressure (bar)
Glass	2,75	500 <sup>a</sup>
Aramid	2,35	470
Carbon	2,35	470
Hybrid	B	
<sup>a</sup> Minimum burst pressure. In addition, calculations shall be performed in accordance with <a href="#">8.3.2</a> to confirm that the minimum stress ratio requirements are also met.		
<sup>b</sup> Stress ratios and burst pressures shall be calculated in accordance with <a href="#">8.3.2</a> .		

### 8.3.3 Stress analysis

The stresses in the composite and in the liner after pre-stress shall be calculated for 0 bar, working pressure, test pressure and design burst pressure. The calculations shall use suitable analysis techniques taking into account nonlinear material behaviour of the liner when establishing stress distributions.

For designs using autofrettage to provide pre-stress, the limits within which the autofrettage pressure shall fall shall be calculated and specified. For designs using controlled tension winding to provide pre-stress, the temperature at which it is performed, the tension required in each layer of composite and the consequent pre-stress in the liner shall be calculated.

### 8.3.4 Maximum defect size

The maximum defect size at any location in the metal liner such that the cylinder meets pressure cycling and LBB requirements, shall be specified. The NDE method shall be capable of detecting the maximum defect size allowed.

The allowable defect size for NDE shall be determined by an appropriate method, e.g. as described in [Annex C](#).

### 8.3.5 Openings

The centre line of openings shall coincide with the longitudinal axis of the cylinder.

### 8.3.6 Fire protection

The cylinder design shall be protected with pressure relief devices. The cylinder, its materials, pressure relief devices and any added insulation or protective material shall be designed collectively to ensure adequate safety during fire conditions in the test specified in A.15. A manufacturer may specify alternative PRD locations for specific vehicle installations in order to optimize safety considerations.

Pressure relief devices shall conform to ISO 15500-13.

## 8.4 Construction and workmanship

### 8.4.1 General

The composite cylinder shall be manufactured from a liner overwrapped with continuous filament windings. Fibre winding operations shall be computer or mechanically controlled. The fibres shall be applied under controlled tension during winding. After winding is complete, thermosetting resins shall be cured by heating, using a predetermined and controlled time-temperature profile.



## 8.4.2 Liner

The manufacture of a metallic liner shall meet the requirements given in [8.2](#), [8.3.2](#) and either [8.5.2.2](#) or [8.5.2.3](#) for the appropriate type of liner construction. Each liner shall be examined for thickness and surface finish before end forming operations are carried out. The base ends of aluminium liners shall not be sealed by a forming process. The base ends of steel liners that have been closed by forming shall be NDE inspected or equivalent. Metal shall not be added in the process of closure at the ends.

## 8.4.3 Neck threads

Threads shall be clean cut, even, without surface discontinuities, to gauge and conform to International Standards.

## 8.4.4 Overwrap

### 8.4.4.1 Fibre winding

The cylinders shall be manufactured by a fibre winding technique. During winding the significant variables shall be monitored within specified tolerances and documented in a winding record. These variables can include but are not limited to:

- a) fibre type including sizing;
- b) manner of impregnation;
- c) winding tension;
- d) winding speed;
- e) number of rovings;
- f) band width;
- g) type of resin and composition;
- h) temperature of the resin;
- i) temperature of the liner;
- j) winding angle.

### 8.4.4.2 Curing of thermosetting resins

If a thermosetting resin is used, the resin shall be cured after filament winding. During the curing, the curing cycle (i.e. the time-temperature history) shall be documented.

The maximum curing time and temperature for cylinders with aluminium alloy liners shall be below the time and temperature that adversely affect metal properties.

### 8.4.4.3 Autofrettage

Autofrettage, if used, shall be carried out before the hydrostatic pressure test. The autofrettage pressure shall be within the limits established in [8.3.3](#).

## 8.4.5 Exterior environmental protection

The exterior of cylinders shall meet the requirements of A.14. Exterior protection may be provided by using:

- a) a surface finish giving adequate protection (e.g. metal sprayed on to aluminium, anodizing); or
- b) the use of a suitable fibre and matrix material (e.g. carbon fibre in resin); or

- c) a protective coating (e.g. organic coating, paint); if exterior coating is part of the design, the requirements of A.9 shall be met; or
- d) a covering impervious to the chemicals listed in A.14.

Any coatings applied to cylinders shall be such that the application process does not adversely affect the mechanical properties of the cylinder. The coating shall be designed to facilitate subsequent in-service inspection and the manufacturer shall provide guidance on coating treatment during such inspection to ensure the continued integrity of the cylinder.

#### **8.4.6 Traceability**

Materials of construction affecting cylinder performance, as determined by the manufacturer, shall be traceable to the extent required to recall cylinders, if necessary.

### **8.5 Prototype testing procedure**

#### **8.5.1 General requirements**

Prototype testing shall be conducted on each new design, on finished cylinders that are representative of normal production and complete with permanent identification marks. The test cylinders or liners shall be selected and the prototype tests specified in 8.5.2 (and detailed in [Annex A](#)) verified by the Inspector. If more cylinders are subjected to the tests than are required by this International Standard, all results shall be documented.

#### **8.5.2 Prototype tests**

##### **8.5.2.1 Tests required**

The Inspector shall select the necessary cylinders or liners for testing and verify:

- a) the tests specified in 8.5.2.2 or 8.5.2.3 (material tests), as appropriate, on one liner;
- b) the test specified in 8.5.2.4 (hydrostatic pressure burst test) on one liner and three cylinders;
- c) the test specified in 8.5.2.5 (ambient temperature pressure cycling test) on two cylinders;
- d) the test specified in 8.5.2.6 (LBB test) on three cylinders;
- e) the test specified in 8.5.2.7 (bonfire test) on one or two cylinders as appropriate;
- f) the test specified in 8.5.2.8 (penetration test) on one cylinder;
- g) the test specified in 8.5.2.9 (environmental test) on one cylinder;
- h) the test specified in 8.5.2.10 (flaw tolerance test) on one cylinder;
- i) the test specified in 8.5.2.11 (high temperature creep test), where appropriate, on one cylinder;
- j) the test specified in 8.5.2.12 (accelerated stress rupture test), on one cylinder;
- k) the test specified in 8.5.2.13 (extreme temperature pressure cycling test) on one cylinder;
- l) the test specified in 8.5.2.14 (resin shear strength test) on one sample coupon representative of the composite overwrap.

##### **8.5.2.2 Material tests for steel liners**

- a) Tensile test

Steel from a finished liner shall meet the requirements of the tensile test in A.1.

b) Impact test

Steel from a finished liner shall meet the requirements of the impact test in A.2.

c) Sulfide stress cracking resistance test

If the upper limit of the specified tensile strength for the steel exceeds 950 MPa, the steel from a finished liner shall meet the requirements of the sulfide stress cracking resistance test in A.3.

### 8.5.2.3 Material tests for aluminium alloy liners

a) Tensile test

Aluminium alloy from a finished liner shall meet the requirements of the tensile test in A.1.

b) Corrosion tests

Aluminium alloy from a finished liner shall meet the requirements of the corrosion tests in A.4.

c) Sustained load cracking tests

Aluminium alloy from a finished liner shall meet the requirements of the sustained load cracking test in A.5.

### 8.5.2.4 Hydrostatic pressure burst test

**8.5.2.4.1** One liner shall be hydrostatically pressurized to failure in accordance with A.12. The burst pressure shall exceed the minimum burst pressure specified for the liner design.

**8.5.2.4.2** Three cylinders shall be hydrostatically pressurized to failure in accordance with A.12. The cylinder burst pressures shall exceed the specified minimum burst pressure and that calculated by the stress analysis for the design, in accordance with [Table 4](#), and in no case be less than the value necessary to meet the stress ratio requirements of [8.3.2](#).

### 8.5.2.5 Ambient temperature pressure cycling test

Two cylinders shall be pressure cycled to failure at ambient temperature in accordance with A.13, or to a minimum of 45 000 cycles. The cylinders shall not fail before reaching the specified service life in years multiplied by 1 000 cycles. Cylinders exceeding 1 000 cycles multiplied by the specified service life in years shall fail by leakage and not by rupture. Cylinders which do not fail within 45 000 cycles shall be destroyed. Cylinders exceeding 45 000 cycles are permitted to fail by rupture. The number of cycles to failure and the location of the failure initiation shall be recorded.

### 8.5.2.6 Leak-before-break (LBB) test

Three cylinders shall be tested in accordance with A.6.

### 8.5.2.7 Bonfire test

One or two cylinders as appropriate shall be tested in accordance with A.15.

### 8.5.2.8 Penetration test

One cylinder shall be tested in accordance with A.16.

### 8.5.2.9 Environmental test

One cylinder shall be tested in accordance with A.14.

#### **8.5.2.10 Flaw tolerance tests**

One cylinder shall be tested in accordance with A.17.

#### **8.5.2.11 High temperature creep test**

In designs where the glass transition temperature of the resin does not exceed 102 °C, one cylinder shall be tested in accordance with A.18.

#### **8.5.2.12 Accelerated stress rupture test**

One cylinder shall be tested in accordance with A.19.

#### **8.5.2.13 Extreme temperature pressure cycling test**

One cylinder shall be tested in accordance with A.7.

#### **8.5.2.14 Resin shear strength test**

Resin materials shall be tested in accordance with A.26.

### **8.5.3 Change of design**

A design change is any change in the selection of structural materials, or a dimensional change not attributable to normal manufacturing tolerances, or any change in the selection of coatings or structural materials. Design changes may be qualified through a reduced test programme. Changes of design specified in [Table 5](#) shall require only the prototype testing as specified in the table.

A fibre material shall be considered to be of a new fibre type when:

- a) the fibre is of a different classification, e.g. glass, aramid, carbon; or
- b) the fibre is produced from a different precursor (starting material), e.g. polyacrylonitrile (PAN), pitch for carbon; or
- c) the nominal fibre modulus, specified by the fibre manufacturer, differs by more than  $\pm 5\%$  from that defined in the prototype tested design; or
- d) the nominal fibre strength, specified by the fibre manufacturer, differs by more than  $\pm 5\%$  from that defined in the prototype tested design.

A resin material shall be considered to be a new resin type when:

- e) the resin is of a different classification, e.g. thermosetting or thermoplastic; or
- f) the resin is of a different type of same classification of resin, e.g. epoxy, polyester, polyethylene, polyamide.

## **8.6 Batch tests on liners and cylinders**

### **8.6.1 General requirements**

Batch testing shall be conducted on liners, and on finished cylinders that are representative of normal production and are complete with permanent identification marks. The cylinders and liners required for testing shall be randomly selected from each batch. If more liners or cylinders are subjected to the tests than are required by this International Standard, all results shall be documented.

### **8.6.2 Required tests**

#### **8.6.2.1 Liner tests**

- a) on one liner, one hydrostatic pressure burst test in accordance with A.12.
- b) on a further liner, or heat treated sample representative of a liner:
  - 1) a check of the critical dimensions against the design (see [6.4.1](#));
  - 2) one tensile test in accordance with A.1; the test results shall satisfy the requirements of the design (see [6.4.1](#));
  - 3) three impact tests in accordance with A.2; the test results shall satisfy the requirements specified in A.2;
  - 4) for steel liners with a specified tensile strength exceeding 1 100 MPa, each new cast of material shall meet the requirements of the sulphide stress cracking test in A.3. A sample of material from each cast may be heat treated and tested by the steel supplier or cylinder manufacturer, provided that the samples have the same strength values specified in the cylinder design.

All liners represented by a batch test that fails to meet the specified requirements shall follow the procedures specified in [8.9](#)

#### **8.6.2.2 Cylinder tests**

- a) on one cylinder, one hydrostatic pressure burst test in accordance with A.12.

If the burst pressure is less than the minimum calculated burst pressure, the procedures specified in [8.9](#) shall be followed.

- b) on a further cylinder:
  - 1) a check of the critical dimensions against the design (see [6.4.1](#));
  - 2) when a protective coating is a part of the design, a coating batch test in accordance with A.24. Where the coating fails to meet the requirements of A.24, the batch shall be 100 % inspected to remove similarly defectively coated cylinders. The coating on all defectively coated cylinders may be stripped using a method that does not affect the integrity of the composite wrapping then recoated. The coating batch test shall then be repeated.

All cylinders represented by a batch test that fails to meet the specified requirements shall follow the procedures specified in [8.9](#).

Table 5 — Change of design for type 2 cylinders

Design change	Type of test									
	Hydrostatic burst	LBB	Pressure cycling at ambient temperature	Bonfire	Penetration	Environmental	Flaw tolerance	High temperature creep	Stress rupture	Torque
	(A.12)	(A.6)	(A.13)	(A.15)	(A.16)	(A.14)	(A.17)	(A.18)	(A.19)	(A.28)
Fibre manufacturer	X		X						X	
Metallic liner material e	X	X	X	X	X	X	X	X	X	
Fibre material	X	X	X	X	X	X	X	X	X	
Resin material		X			X	X	X	X	X	
Diameter change ≤ 20 %	X		X		X <sup>c</sup>					
Diameter change > 20 %	X	X	X	X	X		X			
Length change ≤ 50 %	X			X <sup>a</sup>						
Length change > 50 %	X		X	X <sup>a</sup>						
Working pressure change ≤ 20 % <sup>b</sup>	X		X							
Dome shape	X	X <sup>d</sup>	X							
Opening size	X		X							
Coating change						X				
Pressure relief device				X						
Thread										X
<p><sup>a</sup> Test only required when length increases.</p> <p><sup>b</sup> Only when thickness change proportional to diameter and/or pressure change.</p> <p><sup>c</sup> Only required if diameter decreases.</p> <p><sup>d</sup> Only required for non-ISO 9809-1 designs</p> <p><sup>e</sup> Materials tests are also required.</p>										

### 8.6.2.3 Pressure cycling test

Additionally, a pressure cycling test shall be carried out on finished cylinders in accordance with A.13 at a test frequency defined as:

- a) initially, one cylinder from each batch shall be pressure cycled for a total of 1 000 times the specified service life in years, with a minimum 15 000 cycles;
- b) if on 10 sequential production batches of a design family (i.e. similar materials and processes within the definition of a minor design change, see 8.5.3), none of the pressure cycled cylinders in a) above leaks or ruptures in less than 1 500 cycles multiplied by the specified life in years (minimum 22 500 cycles) then the pressure cycle test may be reduced to one cylinder from every five batches of production;
- c) if on 10 sequential production batches of a design family, none of the pressure cycled cylinders in 8.6.2.2a) leaks or ruptures in less than 2 000 cycles multiplied by the specified service life in years (minimum 30 000 cycles) then the pressure cycle test may be reduced to one cylinder from every 10 batches of production;
- d) should more than 3 months have expired since the last pressure cycle test, then a cylinder from the next batch of production shall be pressure cycle tested in order to maintain the reduced frequency of batch testing in 8.6.2.2b) or 8.6.2.2c);
- e) should any reduced frequency pressure cycle test cylinder in 8.6.2.3b) or 8.6.2.3c) fail to meet the required number of pressure cycles (minimum 22 500 or 30 000 pressure cycles, respectively), then it shall be necessary to repeat the batch pressure cycle test frequency in 8.6.2.3a) for a minimum of 10 production batches in order to re-establish the reduced frequency of batch pressure cycle testing in 8.6.2.3b) or 8.6.2.3c).

Should any cylinder in 8.6.2.3a), 8.6.2.3b) or 8.6.2.3c) fail to meet the minimum cycle life requirement of 1 000 cycles multiplied by the specified service life in years (minimum 15 000 cycles), the requirements of 8.9 shall be met. The pressure cycle test shall then be repeated on an additional three cylinders from that batch. Should any of the three additional cylinders fail to meet the minimum pressure cycling requirement of 1 000 cycles multiplied by the specified service life in years, the batch shall be rejected.

## 8.7 Tests on every liner and cylinder

Production examinations and tests shall be carried out on all liners and cylinders produced in a batch.

Each liner shall be examined either during manufacture or after completion, as appropriate:

- a) by NDE of metallic liners in accordance with [Annex B](#) or demonstrated equivalent method to verify that the maximum defect size does not exceed the size specified in the design as determined in accordance with 8.3.4. The NDE method shall be capable of detecting the maximum size allowed;
- b) to verify that the critical dimensions and mass of the liners are within design tolerances;
- c) to verify conformance to specified surface finish with special attention to deep-drawn surfaces and folds or laps in the neck or shoulder of forged or spun end enclosures or openings;
- d) by hardness tests of metallic liners in accordance with A.8 carried out after the final heat treatment. The values thus determined shall be in the range specified for the design;

Each cylinder shall be examined either during manufacture or after completion, as appropriate:

- e) to verify that the critical dimensions and mass of the completed cylinders and overwrapping are within design tolerances;
- f) to verify the permanent identification marks;
- g) by hydrostatic test of finished cylinders in accordance with A.11. The manufacturer shall establish the appropriate limit of permanent expansion for the test pressure used, but in no case shall the permanent expansion exceed 5 % of the total volumetric expansion measured under the test pressure;

- h) by leak testing of cylinders with base ends formed by spinning. Typical testing procedures include the pneumatic leakage test where the bottom end should be clean and free from all moisture on the test pressure side. The inside area of the cylinder bottom surrounding the closure should be subjected to a pressure equal to at least 2/3 times the test pressure of the cylinder for a minimum of 1 min. This area should be not less than 20 mm in diameter around the closure and at least 6 % of the total bottom area. The opposite side should be covered with water or another suitable medium and closely examined for indication of leakage. Cylinders that leak should be rejected. Other test procedures include a low pressure pneumatic test, and a helium leak test.

## 8.8 Batch acceptance certificate

If the results of batch testing according to [8.6](#) and [8.7](#) are satisfactory, the manufacturer and the Inspector shall sign an acceptance certificate.

NOTE An example of an acceptance certificate (referred to as a “Report of Manufacture and Certificate of Conformance”) is given in [Annex D](#).

## 8.9 Failure to meet test requirements

### 8.9.1 Liners

In the event of failure of a liner to meet the test requirements, re-testing or re-heat treatment and re-testing shall be carried out:

- a) if there is evidence of a fault in carrying out a test, or an error of measurement, a further test shall be performed; if the result of this test is satisfactory, the first test shall be ignored;
- b) if the test has been carried out in a satisfactory manner, the cause of test failure shall be identified.
  - 1) If the failure is considered to be due to the heat treatment applied, the manufacturer may subject all the liners implicated by the failure to a further heat treatment; however if the failure occurs sporadically in a test applied to every liner, then only those liners which fail the test shall require re-heat treatment and re-testing.
    - Whenever liners are re-heat treated, the minimum guaranteed wall thickness shall be maintained.
    - Only the relevant prototype or batch tests needed to prove the acceptability of the new batch shall be performed again. If one or more tests prove even partially unsatisfactory, all liners of the batch shall be rejected, and not placed in service.
  - 2) If the failure is due to a cause other than the heat treatment applied, all defective liners shall be either rejected or repaired by an approved method. Provided that the repaired liners pass the test(s) required for the repair, they shall be re-instated as part of the original batch.

### 8.9.2 Cylinders

In the event of failure of a cylinder to meet test requirements, re-testing or re-heat treatment and re-testing shall be carried out:

- a) if there is evidence of a fault in carrying out a test, or an error of measurement, a further test shall be performed; if the result of this test is satisfactory, the first test shall be ignored;
- b) if the test has been carried out in a satisfactory manner, the cause of test failure shall be identified.

All defective cylinders shall be either rejected or repaired by an approved method. Provided that the repaired cylinders pass the test(s) required for the repair, they shall be re-instated as part of the original batch.



## 9 Requirements for type 3 fully-wrapped cylinders

### 9.1 General

This International Standard does not provide design formulae nor list permissible stresses or strains, but requires the adequacy of the design to be established by appropriate calculations and demonstrated by testing to show that cylinders shall pass the materials, design qualification, production and batch tests specified in this International Standard.

During pressurization, this type of cylinder exhibits behaviour in which the displacements of the composite overwrap and the liner are superimposed. Due to different techniques of manufacture, this International Standard does not give a definite method for design. The design shall ensure a “leak-before-break” failure mode during normal service.

### 9.2 Materials

#### 9.2.1 General requirements

Materials used shall be suitable for the service conditions specified in [Clause 4](#). The design shall ensure that incompatible materials are not in contact.

#### 9.2.2 Controls on chemical composition

##### 9.2.2.1 Steel

Steels shall be aluminium- and/or silicon-killed. The chemical composition of all steels shall be declared and defined at least by:

- a) the carbon, manganese, aluminium, and silicon contents in all cases;
- b) the chromium, nickel, molybdenum, boron and vanadium contents, and that of any other alloying elements intentionally added.

The sulfur and phosphorus content in the cast analysis shall not exceed the values in [Table 6](#).

**Table 6 — Maximum sulfur and phosphorus limits**

sulfur	0,010 % by mass
phosphorus	0,020 % by mass
sulfur + phosphorus	0,025 % by mass

##### 9.2.2.2 Aluminium

Aluminium alloys may be used to produce cylinders provided they meet all requirements of this International Standard and have maximum lead and bismuth contents not exceeding 0,003 %.

NOTE A list of registered alloys is maintained by the Aluminium Association Inc.<sup>3)</sup> and can be found under the “International Registration Records”, entitled “International Alloy Designations and Chemical Composition Limits for Wrought Aluminium and Wrought Aluminium Alloys”.

<sup>3)</sup> Aluminum Association Inc., 900 19th Street N.W., Washington D.C., 20006-2168, USA.

### 9.2.3 Composite materials

#### 9.2.3.1 Resins

The material for impregnation may be thermosetting or thermoplastic resins. Examples of suitable matrix materials are epoxy, modified epoxy, polyester and vinyl ester thermosetting plastics, and polyethylene and polyamide thermoplastic material. The glass transition temperature of the resin material shall be determined in accordance with ASTM D3418.

#### 9.2.3.2 Fibres

Structural reinforcing filament material types shall be glass fibre, aramid fibre or carbon fibre. If carbon fibre reinforcement is used the design shall incorporate means to prevent galvanic corrosion of metallic components of the cylinder.

The manufacturer shall keep on file the published specifications for composite materials, the material manufacturer's recommendations for storage, conditions and shelf life and the material manufacturer's certification that each shipment conforms to said specification requirements. The fibre manufacturer shall certify that the fibre material properties conform to the manufacturer's specifications for the product.

### 9.3 Design requirements

#### 9.3.1 Test pressure

The minimum test pressure used in manufacture shall be 1,5 times working pressure.

#### 9.3.2 Burst pressures and fibre stress ratios

The minimum burst pressure shall not be less than the values given in [Table 7](#). Stress ratio is defined as the stress in the fibre at the specified minimum burst pressure divided by the stress in the fibre at working pressure.

The burst ratio is defined as the burst pressure of the cylinder divided by the working pressure.

The stress ratio calculations shall include:

- a) an analysis method with capability for nonlinear materials (special purpose computer program or finite element analysis program);
- b) correct modelling of the elastic-plastic stress-strain curve for a known liner material;
- c) correct modelling of the mechanical properties of the composite materials;
- d) calculations at autofrettage pressure, zero pressure after autofrettage, working pressure and minimum burst pressure;
- e) account for the pre-stresses from winding tension;
- f) the minimum burst pressure, chosen such that the calculated stress at minimum burst pressure divided by the calculated stress at working pressure meets the stress ratio requirements for the fibre used;
- g) consideration of the load share between the different fibres based on the different elastic moduli of the fibres when analysing cylinders with hybrid reinforcement (two or more different fibres). The stress ratio requirements for each individual fibre type shall be in accordance with the values given in [Table 7](#).

Verification of the stress ratios may also be performed using strain gauges.

NOTE An acceptable method is outlined in [Annex F](#).

**Table 7 — Minimum burst values and stress ratios for type 3 cylinders (with a working pressure of 200 bar)**

Fibre type	Stress Ratio	Burst Pressure Bar
Glass	3,65	700 <sup>a</sup>
Aramid	3,10	600
Carbon	2,35	470
Hybrid	b	
<sup>a</sup> Minimum burst pressure. In addition, calculations shall be performed in accordance with <a href="#">9.3.2</a> to confirm that the minimum stress ratio requirements are also met.		
<sup>b</sup> Stress ratios and burst pressures shall be calculated in accordance with <a href="#">9.3.2</a> .		

### 9.3.3 Stress analysis

A stress analysis shall be performed to justify the minimum design wall thicknesses. It shall include the determination of the stresses in liners and fibres of composite designs.

The stresses in the tangential and longitudinal direction of the cylinder in the composite and in the liner after pre-stress shall be calculated for 0 bar, working pressure, test pressure and design burst pressure. The calculations shall use suitable analysis taking into account nonlinear material behaviour of the liner when establishing stress distributions. The limits within which the autofrettage pressure shall fall shall be calculated.

### 9.3.4 Maximum defect size

The maximum defect size at any location in the metal liner such that the cylinder meets pressure cycling and LBB requirements, shall be specified. The NDE method shall be capable of detecting the maximum defect size allowed. The allowable defect size for NDE shall be determined by an appropriate method, e.g. as per [Annex C](#).

### 9.3.5 Openings

The centre line of openings shall coincide with the longitudinal axis of the cylinder.

### 9.3.6 Fire protection

The cylinder design shall be protected with pressure relief devices. The cylinder, its materials, pressure relief devices and any added insulation or protective material shall be designed collectively to ensure adequate safety during fire conditions in the test specified in A.15. A manufacturer may specify alternative PRD locations for specific vehicle installations to optimize safety considerations.

Pressure relief devices shall conform to ISO 15500-13.

## 9.4 Construction and workmanship

### 9.4.1 General

The composite cylinder shall be manufactured from a liner overwrapped with continuous filament windings. Fibre winding operations shall be computer or mechanically controlled. The fibres shall be applied under controlled tension during winding. After winding is complete, thermosetting resins shall be cured by heating, using a predetermined and controlled time-temperature profile.

#### 9.4.2 Liner

The manufacture of a metallic liner shall meet the requirements specified in [9.2](#), [9.3.2](#) and either [9.5.2.2](#) or [9.5.2.3](#) for the appropriate type of liner construction. Each liner shall be examined for thickness and surface finish before end forming operations are carried out. The base ends of aluminium liners shall not be sealed by a forming process. The base ends of steel liners that have been closed by forming shall be NDE inspected or equivalent. Metal shall not be added in the process of closure at the ends.

#### 9.4.3 Neck threads

Threads shall be clean cut, even, without surface discontinuities, to gauge and conform to International Standards.

#### 9.4.4 Overwrap

##### 9.4.4.1 Fibre winding

The cylinders shall be manufactured by a fibre winding technique. During winding the significant variables shall be monitored within specified tolerances and documented in a winding record. These variables can include but are not limited to:

- a) fibre type including sizing;
- b) manner of impregnation;
- c) winding tension;
- d) winding speed;
- e) number of rovings;
- f) band width;
- g) type of resin and composition;
- h) temperature of the resin;
- i) temperature of the liner;
- j) winding angle.

##### 9.4.4.2 Curing of thermosetting resins

If a thermosetting resin is used, the resin shall be cured after filament winding. During curing, the curing cycle (i.e. the time-temperature history) shall be documented.

The maximum curing time and temperature for cylinders with aluminium alloy liners shall be below the time and temperature that adversely affect metal properties.

##### 9.4.4.3 Autofrettage

Autofrettage, if used, shall be carried out before the hydrostatic pressure test. The autofrettage pressure shall be within the limits established in [9.3.3](#). The compressive stress in the liner at zero pressure shall not cause the liner to buckle or crease.

#### 9.4.5 Exterior environmental protection

The exterior of cylinders shall meet the requirements of the acid environment test described in A.14. Exterior protection may be provided by using:

- a) a surface finish giving adequate protection to metal bosses (e.g. metal sprayed on to aluminium, anodizing); and/or
- b) the use of a suitable fibre and matrix material (e.g. carbon fibre in resin); and/or
- c) a protective coating (e.g. organic coating, paint); if exterior coating is part of the design, the requirements of A.9 shall be met; and/or
- d) a covering impervious to the chemicals listed in A.14.

Any coatings applied to cylinders shall be such that the application process does not adversely affect the mechanical properties of the cylinder. The coating shall be designed to facilitate subsequent in-service inspection and the manufacturer shall provide guidance on coating treatment during such inspection to ensure the continued integrity of the cylinder.

#### 9.4.6 Traceability

Materials of construction affecting cylinder performance, as determined by the manufacturer, shall be traceable to the extent required to recall cylinders, if necessary.

### 9.5 Prototype testing procedure

#### 9.5.1 General requirements

Prototype testing shall be conducted on each new design, on finished cylinders that are representative of normal production and complete with permanent identification marks. The test cylinders or liners shall be selected and the prototype tests specified in 9.5.2 (and detailed in [Annex A](#)) verified by the Inspector. If more cylinders or liners are subjected to the tests than are required by this International Standard, all results shall be documented.

#### 9.5.2 Prototype tests

##### 9.5.2.1 Tests required

In the course of the type approval, the Inspector shall select the necessary cylinders or liners for testing and verify:

- a) the tests specified in 9.5.2.2 or 9.5.2.3 (material tests), as appropriate, on one liner;
- b) the test specified in 9.5.2.4 (hydrostatic pressure burst test) on three cylinders;
- c) the test specified in 9.5.2.5 (ambient temperature pressure cycling test) on two cylinders;
- d) the test specified in 9.5.2.6 (LBB test) on three cylinders;
- e) the test specified in 9.5.2.7 (bonfire test) on one or two cylinders as appropriate;
- f) the test specified in 9.5.2.8 (penetration test) on one cylinder;
- g) the test specified in 9.5.2.9 (environmental test) on one cylinder;
- h) the test specified in 9.5.2.10 (flaw tolerance test) on one cylinder;
- i) the test specified in 9.5.2.11 (high temperature creep test), where appropriate, on one cylinder;
- j) the test specified in 9.5.2.12 (accelerated stress rupture test), on one cylinder;

- k) the test specified in 9.5.2.13 (extreme temperature pressure cycling test) on one cylinder;
- l) the test specified in 9.5.2.14 (resin shear strength) on one sample coupon representative of the composite overwrap;
- m) the test specified in 9.5.2.15 (impact damage test) on at least one cylinder.

#### **9.5.2.2 Material tests for steel liners**

- a) Tensile test

Steel from a finished cylinder or liner shall meet the requirements of the tensile test in A.1.

- b) Impact test

Steel from a finished liner shall meet the requirements of the impact test in A.2.

- c) Sulfide stress cracking resistance test

If the upper limit of the specified tensile strength for the steel exceeds 950 MPa, the steel from a finished liner shall meet the requirements in A.3.

#### **9.5.2.3 Material tests for aluminium alloy liners**

- a) Tensile test

Aluminium alloy from a finished liner shall meet the requirements of the tensile test in A.1.

- b) Corrosion tests

Aluminium alloy from a finished liner shall meet the requirements of the corrosion tests in A.4.

- c) Sustained load cracking tests

Aluminium alloy from a finished liner shall meet the requirements of the sustained load cracking tests in A.5.

#### **9.5.2.4 Hydrostatic pressure burst test**

Three cylinders shall be hydrostatically pressurized to failure in accordance with A.12. The cylinder burst pressures shall exceed the specified minimum burst pressure established by the stress analysis for the design, in accordance with [Table 7](#), and in no case be less than the value calculated to meet the stress ratio requirements of [9.3.2](#).

#### **9.5.2.5 Ambient temperature pressure cycling test**

Two cylinders shall be pressure cycle tested to failure at ambient temperature in accordance with A.13, or to a minimum of 45 000 cycles. The cylinders shall not fail before reaching the specified service life in years multiplied by 1 000 cycles. Cylinders exceeding 1 000 cycles multiplied by the specified service life in years shall fail by leakage and not by rupture. Cylinders which do not fail within 45 000 cycles shall be destroyed. Cylinders exceeding 45 000 cycles are permitted to fail by rupture. The number of cycles to failure and the location of the failure initiation shall be recorded.

#### **9.5.2.6 Leak-before-break (LBB) test**

Three cylinders shall be tested in accordance with A.6.

#### **9.5.2.7 Bonfire test**

One or two cylinders as appropriate shall be tested in accordance with A.15.

**9.5.2.8 Penetration test**

One cylinder shall be tested in accordance with A.16.

**9.5.2.9 Environmental test**

One cylinder shall be tested in accordance with A.14.

**9.5.2.10 Flaw tolerance tests**

One cylinder shall be tested in accordance with A.17.

**9.5.2.11 High temperature creep test**

In designs where the glass transition temperature of the resin does not exceed 102 °C, one cylinder shall be tested in accordance with A.18.

**9.5.2.12 Accelerated stress rupture test**

One cylinder shall be tested in accordance with A.19.

**9.5.2.13 Extreme temperature pressure cycling test**

One cylinder shall be tested in accordance with A.7.

**9.5.2.14 Resin shear strength**

Resin materials shall be tested in accordance with A.26.

**9.5.2.15 Impact damage test**

One (or more) finished cylinders shall be impact damage tested in accordance with A.20.

**9.5.3 Change of design**

A design change is any change in the selection of structural materials, or a dimensional change not attributable to normal manufacturing tolerances, or any change in the selection of coatings or structural materials. Design changes may be qualified through a reduced test programme. Changes of design specified in [Table 8](#) shall require design qualification testing as specified in the table.

A fibre material shall be considered to be of a new design when:

- a) the fibre is of a different classification, e.g. glass, aramid, carbon;
- b) the fibre is produced from a different precursor (starting material), e.g. polyacrylonitrile (PAN), pitch for carbon;
- c) the nominal fibre modulus, specified by the fibre manufacturer, differs by more than  $\pm 5\%$  from that defined in the prototype tested design;
- d) the nominal fibre strength, specified by the fibre manufacturer, differs by more than  $\pm 5\%$  from that defined in the prototype tested design.

A resin material shall be considered to be a new resin type when:

- e) the resin is of a different classification, e.g. thermosetting or thermoplastic
- f) the resin is of a different type of same classification of resin, e.g. epoxy, polyester, polyethylene, polyamide.

Table 8 — Change of design for type 3 cylinders

Design change	Type of test										
	Hydrostatic burst	LBB	Pressure cycling at ambient temperature	Bonfire	Penetration	Environmental	Flaw tolerance	High temperature creep	Stress rupture	Impact damage	Torque
	(A.12)	(A.6)	(A.13)	(A.15)	(A.16)	(A.14)	(A.17)	(A.18)	(A.19)	(A.20)	(A.28)
Fibre manufacturer	X		X						X	X	
Metallic liner material <sup>d</sup>	X	X	X	X	X	X	X	X	X	X	
Fibre material	X	X	X	X	X	X	X	X	X	X	
Resin material		X			X	X	X	X			
Diameter change ≤ 20 %	X		X		X <sup>c</sup>						
Diameter change > 20 %	X	X	X	X	X		X			X	
Length change ≤ 50 %	X			X <sup>a</sup>							
Length change > 50 %	X		X	X <sup>a</sup>						X	
Working pressure change ≤ 20 % <sup>b</sup>	X		X								
Dome shape	X	X	X								
Opening size	X	X	X								
Coating change						X					
Pressure relief device				X							
Thread											X

<sup>a</sup> Test only required when length increases.

<sup>b</sup> Only when thickness change proportional to diameter and/or pressure change.

<sup>c</sup> Only required if diameter decreases.

<sup>d</sup> Materials tests are also required.



## 9.6 Batch tests on liners and cylinders

### 9.6.1 General requirements

Batch testing shall be conducted on liners, and on finished cylinders that are representative of normal production and are complete with permanent identification marks. The cylinders and liners required for testing shall be randomly selected from each batch. If more cylinders or liners are subjected to the tests than are required by this International Standard, all results shall be documented. Where defects are detected in overwrapping before any autofrettage or hydrostatic pressure testing, the overwrapping may be completely removed and replaced.

### 9.6.2 Liner tests

On a liner, or heat treated sample representative of a finished liner:

- a) a check of the critical dimensions against the design (see [6.4.1](#));
- b) one tensile test in accordance with A.1; the test results shall satisfy the requirements of the design (see [6.4.1](#));
- c) for steel liners, three impact tests in accordance with A.2; the test results shall satisfy the requirements specified in A.2;
- d) for steel liners with a tensile strength exceeding 1100 MPa, each new cast of material shall meet the requirements of the sulphide stress cracking test in A.3. A sample of material from each cast may be heat treated and tested by the steel supplier or cylinder manufacturer, provided that the samples have the same strength values specified in the cylinder design.

All liners represented by a batch test that fails to meet the requirements specified shall follow the procedures specified in [9.9](#).

### 9.6.3 Cylinder tests

- a) on one cylinder, one hydrostatic pressure burst test in accordance with A.12.
- b) on a further cylinder:
  - 1) a check of the critical dimensions against the design (see [6.4.1](#));
  - 2) when a protective coating is a part of the design, a coating batch test in accordance with A.24. Where the coating fails to meet the requirements of A.24, the batch shall be 100 % inspected to remove similarly defectively coated cylinders. The coating on all defectively coated cylinders may be stripped using a method that does not affect the integrity of the composite wrapping then recoated. The coating batch test shall then be repeated.
- c) a pressure cycling test shall be carried out on a finished cylinder in accordance with A.13 at a test frequency defined as:
  - 1) initially, one cylinder from each batch shall be pressure cycled for a total of 1 000 times the specified service life in years, with a minimum 15 000 cycles;
  - 2) if on 10 sequential production batches of a design family (i.e. similar materials and processes within the definition of a minor design change, see 9.5.3), none of the pressure cycled cylinders in 9.6.3c)1) leaks or ruptures in less than 1 500 cycles multiplied by the specified life in years (minimum 22 500 cycles) then the pressure cycle test may be reduced to one cylinder from every five batches of production;
  - 3) if on 10 sequential production batches of a design family, none of the pressure cycled cylinders in 9.6.3c)1) leaks or ruptures in less than 2 000 cycles multiplied by the specified service life in years (minimum 30 000 cycles) then the pressure cycle test may be reduced to one cylinder from every 10 batches of production;

- 4) should more than 3 months have expired since the last pressure cycle test, then a cylinder from the next batch of production shall be pressure cycle tested in order to maintain the reduced frequency of batch testing in 9.6.3c)2) or 9.6.3c)3);
- 5) should any reduced frequency pressure cycle test cylinder in 9.6.3c)2) or 9.6.3c)3) fail to meet the required number of pressure cycles (minimum 22 500 or 30 000 pressure cycles, respectively), then it shall be necessary to repeat the batch pressure cycle test frequency in 9.6.3a) for a minimum 10 production batches in order to re-establish the reduced frequency of batch pressure cycle testing in 9.6.3b) or 9.6.3c).

Should any cylinder in 9.6.3c)1), 9.6.3c)2), or 9.6.3c)3) fail to meet the minimum cycle life requirement of 1 000 cycles multiplied by the specified service life in years (minimum 15 000 cycles), the cause of failure shall be determined and corrected following the procedures in 9.9. The pressure cycle test shall then be repeated on an additional three cylinders from that batch. Should any of the three additional cylinders fail to meet the minimum pressure cycling requirement of 1 000 cycles multiplied by the specified service life in years, the batch shall be rejected.

#### 9.6.4 Cylinder failures

All cylinders represented by a batch test that fails to meet the requirements specified shall follow the procedures specified in 9.9.

### 9.7 Tests on every liner and cylinder

#### 9.7.1 General

Production examinations and tests shall be carried out on all liners and cylinders produced in a batch.

#### 9.7.2 Liner tests

Each liner shall be examined either during manufacture or after completion, as appropriate:

- a) by NDE of metallic liners in accordance with Annex B or demonstrated equivalent method to verify that the maximum defect size does not exceed the size specified in the design as determined in accordance with 9.3.4. The NDE method shall be capable of detecting the maximum size allowed;
- b) to verify that the critical dimensions and mass of the liners are within design tolerances;
- c) to verify conformance to specified surface finish with special attention to deep-drawn surfaces and folds or laps in the neck or shoulder of forged or spun end enclosures or openings;
- d) by hardness tests of metallic liners in accordance with A.8 carried out after the final heat treatment; the values thus determined shall be in the range specified for the design.

#### 9.7.3 Cylinder tests

Each cylinder shall be examined either during manufacture and/or after completion, as appropriate:

- a) to verify that the critical dimensions and mass of the completed cylinders and overwrapping are within design tolerances;
- b) to verify the permanent identification marks;
- c) by hydrostatic test of finished cylinders in accordance with A.11. The manufacturer shall establish the appropriate limit of permanent expansion for the test pressure used, but in no case shall the permanent expansion exceed 5 % of the total volumetric expansion measured under the test pressure.
- d) by leak testing of cylinders with base ends formed by spinning. Typical testing procedures include the pneumatic leakage test where the bottom end should be clean and free from all moisture on the test pressure side. The inside area of the cylinder bottom surrounding the closure should be

subjected to a pressure equal to at least  $2/3$  times the test pressure of the cylinder for a minimum of 1 min. This area should be not less than 20 mm in diameter around the closure and at least 6 % of the total bottom area. The opposite side should be covered with water or another suitable medium and closely examined for indication of leakage. Cylinders that leak should be rejected. Other test procedures include a low pressure pneumatic test, and a helium leak test.

## 9.8 Batch acceptance certificate

If the results of batch testing in accordance with 9.6 and 9.7 are satisfactory, the manufacturer and the Inspector shall sign an acceptance certificate.

NOTE An example of an acceptance certificate (referred to as a "Report of Manufacture and Certificate of Conformance") is given in [Annex D](#).

## 9.9 Failure to meet test requirements

### 9.9.1 Liners

In the event of failure of a liner to meet test requirements, re-testing or re-heat treatment and re-testing shall be carried out:

- a) if there is evidence of a fault in carrying out a test, or an error of measurement, a further test shall be performed; if the result of this test is satisfactory, the first test shall be ignored;
- b) if the test has been carried out in a satisfactory manner, the cause of test failure shall be identified.
  - 1) If the failure is considered to be due to the heat treatment applied, the manufacturer may subject all the liners implicated by the failure to a further heat treatment; however if the failure occurs sporadically in a test applied to every liner, then only those liners which fail the test shall require re-heat treatment and re-testing.
    - Whenever liners are re-heat treated, the minimum guaranteed wall thickness shall be maintained.
    - Only the relevant prototype or batch tests needed to prove the acceptability of the new batch shall be performed again. If one or more tests prove even partially unsatisfactory, all liners of the batch shall be rejected, and not placed in service.
  - 2) If the failure is due to a cause other than the heat treatment applied, all defective liners shall be either rejected or repaired by an approved method. Provided that the repaired liners pass the test(s) required for the repair, they shall be re-instated as part of the original batch.

### 9.9.2 Cylinders

In the event of failure of a cylinder to meet test requirements, re-testing shall be carried out:

- a) if there is evidence of a fault in carrying out a test, or an error of measurement, a further test shall be performed; if the result of this test is satisfactory, the first test shall be ignored;
- b) if the test has been carried out in a satisfactory manner, the cause of test failure shall be identified. All defective cylinders shall be either rejected or repaired by an approved method. Provided that the repaired cylinders pass the test(s) required for the repair, they shall be re-instated as part of the original batch.

## 10 Requirements for type 4 fully-wrapped composite cylinders

### 10.1 General

This International Standard does not provide design formulae nor list permissible stresses or strains, but requires the adequacy of the design to be established by appropriate calculations and demonstrated by testing to show that cylinders shall pass the materials, design qualification, production and batch tests specified in this International Standard.

The design shall ensure a “leak-before-break” failure mode.

### 10.2 Materials

#### 10.2.1 General requirements

Materials used shall be suitable for the service conditions specified in [Clause 4](#). The design shall ensure that incompatible materials are not in contact.

#### 10.2.2 Resins

The material for impregnation may be thermosetting or thermoplastic resins. Examples of suitable matrix materials are epoxy, modified epoxy, polyester and vinyl ester thermosetting plastics, and polyethylene and polyamide thermoplastic material.

The glass transition temperature of the resin material shall be determined in accordance with ASTM D 3418.

#### 10.2.3 Fibres

Structural reinforcing filament material types shall be glass fibre, aramid fibre or carbon fibre. If carbon fibre reinforcement is used the design shall incorporate a means of preventing galvanic corrosion of metallic components of the cylinder.

The manufacturer shall keep on file the published specifications for composite materials, the material manufacturer's recommendations for storage, conditions and shelf life, and the material manufacturer's certification that each shipment conforms to said specification requirements. The fibre manufacturer shall certify that the fibre material properties conform to the manufacturer's specifications for the product.

#### 10.2.4 Plastic liners

The polymeric material shall be compatible with the service conditions specified in [Clause 4](#).

#### 10.2.5 Metal bosses

The metal bosses connected to the non-metallic liner shall be of a material compatible with the service conditions specified in [Clause 4](#).

### 10.3 Design requirements

#### 10.3.1 Test pressure

The minimum test pressure used in manufacture shall be 1,5 times working pressure.

#### 10.3.2 Burst pressures and fibre stress ratios

The minimum burst pressure shall be not less than the values given in [Table 9](#). Stress ratio is defined as the stress in the fibre at the specified minimum burst pressure divided by the stress in the fibre at working pressure.

The burst ratio is defined as the burst pressure of the cylinder divided by the working pressure.

For type 4 designs, the stress ratio is equal to the burst ratio.

For designs using hybrid reinforcement (two or more different fibres), the load share between the different fibres based on the different elastic moduli of the fibres shall be considered in the analysis. The stress ratio requirements for each individual fibre type shall be in accordance with the values given in [Table 9](#).

Verification of the stress ratios may also be performed using strain gauges.

NOTE An acceptable method is outlined in [Annex F](#).

**Table 9 — Minimum burst values and stress ratios for type 4 cylinders (with a working pressure of 200 bar)**

Fibre type	Stress Ratio	Burst Pressure bar
Glass	3,65	730
Aramid	3,10	620
Carbon	2,35	470
Hybrid	a	
a Stress ratios and burst pressures shall be calculated in accordance with <a href="#">10.3.2</a> .		

### 10.3.3 Stress analysis

A stress analysis shall be performed to justify the minimum design wall thicknesses. It shall include the determination of the stresses in fibres of composite designs. The stresses in the tangential and longitudinal direction of the composite cylinder shall be calculated. The pressures used for these calculations shall be 0 bar, working pressure, test pressure and design burst pressure. The calculations shall use suitable analysis techniques to establish stress distribution throughout the cylinder.

### 10.3.4 Openings

Openings are permitted in the end bosses only. The centre line of openings shall coincide with the longitudinal axis of the cylinder.

### 10.3.5 Fire protection

The cylinder design shall be protected with pressure relief devices. The cylinder, its materials, pressure relief devices and any added insulation or protective material shall be designed collectively to ensure adequate safety during fire conditions in the test specified in A.15. A manufacturer may specify alternative PRD locations for specific vehicle installations in order to optimize safety considerations.

Pressure relief devices shall conform to ISO 15500-13.

## 10.4 Construction and workmanship

### 10.4.1 General

The composite cylinder shall be manufactured from a liner overwrapped with continuous filament windings. Fibre winding operations shall be computer or mechanically controlled. The fibres shall be applied under controlled tension during winding. After winding is complete, thermosetting resins shall be cured by heating, using a predetermined and controlled time-temperature profile.

### 10.4.2 Neck threads

Threads shall be clean cut, even, without surface discontinuities, to gauge and conform to International Standards.

### 10.4.3 Curing of thermosetting resins

The curing temperature for thermosetting resins shall be at least 10 °C below the softening temperature of the plastic liner.

### 10.4.4 Exterior environmental protection

The exterior of cylinders shall meet the requirements of A.14. Exterior protection may be provided by using:

- a) a surface finish giving adequate protection to metal bosses (e.g. metal sprayed on to aluminium, anodizing); and/or
- b) the use of a suitable fibre and matrix material (e.g. carbon fibre in resin); and/ or
- c) a protective coating (e.g. organic coating, paint); if exterior coating is part of the design, the requirements of A.9 shall be met; and/or
- d) a covering impervious to the chemicals listed in A.14.

Any coatings applied to cylinders shall be such that the application process does not adversely affect the mechanical properties of the cylinder. The coating shall be designed to facilitate subsequent in-service inspection and the manufacturer shall provide guidance on coating treatment during such inspection to ensure the continued integrity of the cylinder.

### 10.4.5 Traceability

Materials of construction affecting cylinder performance, as determined by the manufacturer, shall be traceable to the extent required to recall cylinders, if necessary.

## 10.5 Prototype testing procedure

### 10.5.1 General

Prototype testing shall be conducted on each new design, on finished cylinders that are representative of normal production and complete with permanent identification marks. The test cylinders or liners shall be selected and the prototype tests specified in 10.5.2 (and detailed in [Annex A](#)) verified by the Inspector. If more cylinders or liners are subjected to the tests than are required by this International Standard, all results shall be documented.

### 10.5.2 Prototype tests

#### 10.5.2.1 Tests required

In the course of the type approval, the Inspector shall select the necessary cylinders or liners for testing and verify:

- a) the tests specified in 10.5.2.2 (material tests), on one liner;
- b) the test specified in 10.5.2.3 (hydrostatic pressure burst test) on three cylinders;
- c) the test specified in 10.5.2.4 (ambient temperature pressure cycling test) on two cylinders;
- d) the test specified in 10.5.2.5 (LBB test) on three cylinders;
- e) the test specified in 10.5.2.6 (bonfire test) on one or two cylinders as appropriate;

- f) the test specified in 10.5.2.7 (penetration test) on one cylinder;
- g) the test specified in 10.5.2.8 (environmental test) on one cylinder;
- h) the test specified in 10.5.2.9 (flaw tolerance test) on one cylinder;
- i) the test specified in 10.5.2.10 (high temperature creep test), where appropriate, on one cylinder;
- j) the test specified in 10.5.2.11 (accelerated stress rupture test), on one cylinder;
- k) the test specified in 10.5.2.12 (extreme temperature pressure cycling test) on one cylinder;
- l) the test specified in 10.5.2.13 (resin shear strength) on one sample coupon representative of the composite overwrap;
- m) the test specified in 10.5.2.14 (drop test) on at least one cylinder;
- n) the test specified in 10.5.2.15 (boss torque test) on one cylinder;
- o) the test specified in 10.5.2.16 (permeation test) on one cylinder;
- p) the test specified in 10.5.2.17 (natural gas cycling test) on one cylinder.

#### **10.5.2.2 Material tests for plastic liners**

The tensile yield strength and ultimate elongation shall be determined in accordance with A.22. The softening temperature shall be determined in accordance with A.23.

#### **10.5.2.3 Hydrostatic pressure burst test**

Three cylinders shall be hydrostatically pressurized to failure in accordance with A.12. The cylinder burst pressures shall exceed the specified minimum burst pressure established by the stress analysis for the design, in accordance with [Table 9](#), and in no case less than the value necessary to meet the stress ratio requirements of [10.3.2](#).

#### **10.5.2.4 Ambient temperature pressure cycling test**

Two cylinders shall be pressure cycle tested at ambient temperature in accordance with A.13 to failure, or to a minimum of 45 000 cycles. The cylinders shall not fail before reaching the specified service life in years multiplied by 1 000 cycles. Cylinders exceeding 1 000 cycles multiplied by the specified service life in years shall fail by leakage and not by rupture. Cylinders which do not fail within 45 000 cycles shall be destroyed. Cylinders exceeding 45 000 cycles are permitted to fail by rupture. The number of cycles to failure and the location of the failure initiation shall be recorded.

#### **10.5.2.5 Leak-before-break (LBB) test**

Three cylinders shall be tested in accordance with A.6.

#### **10.5.2.6 Bonfire test**

One or two cylinders as appropriate shall be tested in accordance with A.15.

#### **10.5.2.7 Penetration test**

One cylinder shall be tested in accordance with A.16.

#### **10.5.2.8 Environmental test**

One cylinder shall be tested in accordance with A.14.

**10.5.2.9 Flaw tolerance tests**

One cylinder shall be tested in accordance with A.17.

**10.5.2.10 High temperature creep test**

In designs where the glass transition temperature of the resin does not exceed 102 °C, one cylinder shall be tested in accordance with A.18.

**10.5.2.11 Accelerated stress rupture test**

One cylinder shall be tested in accordance with A.19.

**10.5.2.12 Extreme temperature pressure cycling test**

One cylinder shall be tested in accordance with A.7.

**10.5.2.13 Resin shear strength**

Resin materials shall be tested in accordance with A.26.

**10.5.2.14 Impact damage test**

One (or more) finished cylinders shall be impact damage tested in accordance with A.20.

**10.5.2.15 Boss torque test**

One cylinder shall be tested in accordance with A.25.

**10.5.2.16 Permeation test**

One cylinder shall be tested for permeation in accordance with A.21.

**10.5.2.17 Natural gas cycling test**

One cylinder shall be tested in accordance with A.27.

**10.5.3 Change of design**

A design change is, a dimensional change not attributable to normal manufacturing tolerances, or any change in the selection of coatings or structural materials.

Design changes may be qualified through a reduced test programme. Changes of design specified in [Table 10](#) shall require design qualification testing as specified in the table.

Either a fibre material change or a fibre manufacturer change shall be considered to be of a new design and require full qualification when:

- a) the fibre is of a different classification, e.g. glass, aramid, carbon; or
- b) the fibre is produced from a different precursor (starting material), e.g. polyacrylonitrile (PAN), pitch for carbon; or
- c) the nominal fibre modulus, specified by the fibre manufacturer, differs by more than  $\pm 5$  % from that defined in the prototype tested design; or
- d) the nominal fibre strength, specified by the fibre manufacturer, differs by more than  $\pm 5$  % from that defined in the prototype tested design.



Fibre materials that are within the above limits are considered equivalent fibres and are eligible for the reduced test programme described in [Table 10](#). Note that a change in fibre material does not require tests that evaluate the performance of plastic liners, e.g. permeation testing and natural gas cycle testing.

A resin material shall be considered to be a new resin type when:

- e) the resin is of a different classification, e.g. thermosetting or thermoplastic;
- f) the resin is of a different type of same classification of resin, e.g. epoxy, polyester, polyethylene, polyamide.

Table 10 — Change of design for type 4 cylinders

Design change	Type of test													
	Permeation (A.21)	CNG cycling (A.27)	Hydrostatic burst (A.12)	Boss torque (A.25)	LBB (A.6)	Pressure cycling at ambient temperature (A.13)	Bonfire (A.15)	Penetration (A.16)	Environmental (A.14)	Flaw tolerance (A.17)	High temperature creep (A.18)	Stress rupture (A.19)	Impact damage (A.20)	Torque (A.28)
Fibre manufacturer			X			X						X	X	
Plastic liner material	X	X	X	X			X				X		X	
Fibre material			X		X	X	X	X	X	X	X	X	X	
Resin material					X			X	X	X	X			
Diameter change ≤ 20 %			X			X		X <sup>e</sup>						
Diameter change > 20 % <sup>b</sup>			X		X	X	X	X		X			X	
Length change ≤ 50 %			X				X <sup>a</sup>							

<sup>a</sup> Test only required when length increases.

<sup>b</sup> Only when thickness change proportional to diameter and/or pressure change.

<sup>c</sup> Only if boss/liner interface is affected.

<sup>d</sup> Only if boss/liner or boss composite interface is affected or torque requirements change.

<sup>e</sup> Only required if diameter decreases.

Table 10 (continued)

Design change	Type of test													
	Permeation (A.21)	CNG cycling (A.27)	Hydrostatic burst (A.12)	Boss torque (A.25)	LBB (A.6)	Pressure cycling at ambient temperature (A.13)	Bonfire (A.15)	Penetration (A.16)	Environmental (A.14)	Flaw tolerance (A.17)	High temperature creep (A.18)	Stress rupture (A.19)	Impact damage (A.20)	Torque (A.28)
Length change > 50 %			X			X	X <sup>a</sup>						X	
Working pressure change ≤ 20 %			X			X								
Dome shape			X		X	X								
Opening size (composite)			X		X	X								
Coating change									X					
End boss design	X <sup>c</sup>	X <sup>c</sup>		X <sup>d</sup>										
Pressure relief device							X							

<sup>a</sup> Test only required when length increases.  
<sup>b</sup> Only when thickness change proportional to diameter and/or pressure change.  
<sup>c</sup> Only if boss/liner interface is affected.  
<sup>d</sup> Only if boss/liner or boss composite interface is affected or torque requirements change.  
<sup>e</sup> Only required if diameter decreases.

Table 10 (continued)

Design change	Type of test													
	Permeation (A.21)	CNG cycling (A.27)	Hydrostatic burst (A.12)	Boss torque (A.25)	LBB (A.6)	Pressure cycling at ambient temperature (A.13)	Bonfire (A.15)	Penetration (A.16)	Environmental (A.14)	Flaw tolerance (A.17)	High temperature creep (A.18)	Stress rupture (A.19)	Impact damage (A.20)	Torque (A.28)
Thread														X
a	Test only required when length increases.													
b	Only when thickness change proportional to diameter and/or pressure change.													
c	Only if boss/liner interface is affected.													
d	Only if boss/liner or boss composite interface is affected or torque requirements change.													
e	Only required if diameter decreases.													

## 10.6 Batch tests

### 10.6.1 General requirements

Batch testing shall be conducted on finished cylinders that are representative of normal production and are complete with permanent identification marks. The cylinder(s) and liner(s) required for testing shall be randomly selected from each batch. If more cylinders are subjected to the tests than are required by this International Standard, all results shall be documented.

### 10.6.2 Required tests

#### 10.6.2.1 Burst test

On one cylinder, one hydrostatic pressure burst test in accordance with A.12.

If the burst pressure is less than the minimum calculated burst pressure, the procedures specified in [10.9](#) shall be followed.

#### 10.6.2.2 Materials tests

On one cylinder, or liner, or sample representative of a finished cylinder:

- a) a check of the critical dimensions against the design (see [6.4.1](#));
- b) one tensile test of the plastic liner in accordance with A.22; the test results shall satisfy the requirements of the design (see [6.4.1](#));
- c) the softening temperature of the plastic liner shall be tested in accordance with A.23, and meet the requirements of the design;
- d) when a protective coating is a part of the design, a coating batch test in accordance with A.24. Where the coating fails to meet the requirements of A.24, the batch shall be 100 % inspected to remove similarly defectively coated cylinders. The coating on all defectively coated cylinders may be stripped using a method that does not affect the integrity of the composite wrapping then recoated. The coating batch test shall then be repeated.

#### 10.6.2.3 Pressure cycling test

A pressure cycling test shall be carried out on finished cylinders in accordance with A.13 at a test frequency defined as follows:

- a) initially, on one cylinder from each batch the end boss shall be torque tested in accordance with A.25. The cylinder shall then be pressure cycled for a total of 1 000 times the specified service life in years, with a minimum 15 000 cycles. Following the required pressure cycling, the cylinder shall be leak tested in accordance with the method described in A.10;
- b) if on 10 sequential production batches of a design family (i.e. similar materials and processes within the definition of a minor design change, see 10.5.3), none of the pressure cycled cylinders in 10.6.2.2a) leaks or ruptures in less than 1 500 cycles multiplied by the specified life in years (minimum 22 500 cycles) then the pressure cycle test may be reduced to one cylinder from every five batches of production;
- c) if on 10 sequential production batches of a design family, none of the pressure cycled cylinders in 10.6.2.2a) leaks or ruptures in less than 2 000 cycles multiplied by the specified service life in years (minimum 30 000 cycles) then the pressure cycle test may be reduced to one cylinder from every 10 batches of production;

- d) should more than 3 months have expired since the last pressure cycle test, then a cylinder from the next batch of production shall be pressure cycle tested in order to maintain the reduced frequency of batch testing in 10.6.2.2b) or 10.6.2.2c);
- e) should any reduced frequency pressure cycle test cylinder in 10.6.2.2b) or 10.6.2.2c) fail to meet the required number of pressure cycles (minimum 22 500 or 30 000 pressure cycles, respectively), then it shall be necessary to repeat the batch pressure cycle test frequency in 10.6.2.2a) for a minimum of 10 production batches in order to re-establish the reduced frequency of batch pressure cycle testing in 10.6.2.2b) or 10.6.2.2c);
- f) If a cylinder design has passed the leak-before-break test (A.6) without leaking, and if on 10 sequential production batches none of the design family leaks within the prescribed cycle test, then the frequency of pressure cycling test may be reduced to one every one every 20 production batches, and at least one every 6 months.

Should any cylinder in 10.6.2.2a), 10.6.2.2b), or 10.6.2.2c) fail to meet the minimum cycle life requirement of 1 000 cycles multiplied by the specified service life in years (minimum 15 000 cycles), the cause of failure shall be determined and corrected following the procedures in [10.9](#). The pressure cycle test shall then be repeated on an additional three cylinders from that batch. Should any of the three additional cylinders fail to meet the minimum pressure cycling requirement of 1 000 cycles multiplied by the specified service life in years, the batch shall be rejected.

#### 10.6.2.4 Failure to meet batch test requirements

All cylinders or liners represented by a batch test that fails to meet the requirements specified shall follow the procedures specified in [10.9](#).

### 10.7 Tests on every cylinder

Production examinations and tests shall be carried out on all cylinders produced in a batch.

Each cylinder shall be examined during manufacture and/or after completion, as appropriate:

- a) by inspection of liners to verify that the maximum defect size present is smaller than the size specified in the design;
- b) to verify that the critical dimensions and mass of the completed cylinder and of any liner and overwrapping are within design tolerances;
- c) to verify conformance to specified surface finish;
- d) to verify the permanent identification marks;
- e) by hydrostatic test of finished cylinders in accordance with A.11. The manufacturer shall define the appropriate limit of elastic expansion for the test pressure used, but in no case shall the elastic expansion of any cylinder exceed the average batch value by more than 10 %;
- f) by leak test in accordance with A.10.

### 10.8 Batch acceptance certificate

If the results of batch testing according to [10.6](#) and [10.7](#) are satisfactory, the manufacturer and the Inspector shall sign an acceptance certificate.

NOTE An example of an acceptance certificate (referred to as a "Report of Manufacture and Certificate of Conformance") is given in [Annex D](#).

## 10.9 Failure to meet test requirements

In the event of failure to meet test requirements re-testing shall be carried out:

- a) if there is evidence of a fault in carrying out a test, or an error of measurement, a further test shall be performed; if the result of this test is satisfactory, the first test shall be ignored;
- b) if the test has been carried out in a satisfactory manner, the cause of test failure shall be identified.
  - 1) All defective cylinders shall be rejected or repaired by an approved method. Provided that the repaired cylinders pass the test(s) required for the repair, they shall be re-instated as part of the original batch.
  - 2) The new batch shall be retested. All the relevant prototype or batch tests needed to prove the acceptability of the new batch shall be performed again. If one or more tests prove even partially unsatisfactory, all cylinders of the batch shall be rejected, and not placed in service.

## 11 Marking

On each cylinder the manufacturer shall provide clear, permanent markings not less than 6 mm high. Marking shall be made either by labels incorporated into resin coatings, labels attached by adhesive, low stress stamps used on the thickened ends of type 1 and 2 designs, or any combination thereof. For composite cylinders, permanent markings may be achieved by use of a printed label encapsulated either by placing it under the resin or by covering it with a permanent transparent layer. Multiple labels are allowed and should be located such that they are not obscured by mounting brackets.

Each cylinder conforming to this International Standard shall be marked with at least:

- a) the words “CNG ONLY”;
- b) the words “DO NOT USE AFTER XX/XXXX”, where XX/XXXX identifies the month and year of expiry.

The period between the dispatch date and the expiry date shall not exceed the specified service life. The expiry date may be applied to the cylinder at the time of dispatch, provided that the cylinders have been stored in a dry location without internal pressure;

- c) manufacturer’s identification;
- d) cylinder identification (a serial number unique for every cylinder);
- e) working pressure and temperature;
- f) reference to this International Standard, “ISO 11439:2013”, along with cylinder type and certification registration number (if applicable);
- g) the words “Use only a manufacturer-specified PRD”;
- h) when labels are used, a unique identification number and the manufacturer’s identification stamped on an exposed metal surface to permit tracing in the event that the label is destroyed;
- i) date of manufacture (month and year);
- j) any additional markings as required by the Inspector of the country(ies) of use.

The markings shall be placed in the listed sequence but the specific arrangement may be varied to match the space available. An acceptable example is:

**CNG ONLY**

**DO NOT USE AFTER 03/2029**

Manufacturer’s name/Manufacturer’s serial number

## ISO 11439:2013(E)

200 bar/15 °C

ISO 11439:2013 type 2 (registration no.)

“Use only manufacturer-specified PRD”

**Manufacture date 03/2013**

### **12 Preparation for dispatch**

Prior to dispatch from the manufacturer's shop, every cylinder shall be internally clean and dry. Cylinders not immediately closed by the fitting of a valve, and safety devices if applicable, shall have plugs which prevent entry of moisture and protect threads, fitted to all openings. A corrosion inhibitor (e.g. oil-containing) shall be sprayed into all steel cylinders and liners prior to dispatch. Any applied internal pressure shall not exceed 3 bar.

The manufacturer's statement of service and all necessary information and instructions to ensure the proper handling, use and in-service inspection of the cylinder shall be supplied to the purchaser.

NOTE Guidance on the content of the instructions is given in [Annex G](#).



## Annex A (normative)

### Test methods and criteria

#### A.1 Tensile tests for steel and aluminium cylinders and liners

A tensile test shall be carried out on material taken from the cylindrical part of the finished cylinder or liner using a rectangular test piece shaped in accordance with the method described in ISO 9809-1 for steel and ISO 7866 for aluminium. The two faces of the test piece representing the inside and outside surface of the cylinder shall not be machined.

The tensile test shall be carried out in accordance with ISO 6892-1.

The tensile strength shall meet the manufacturer's design specifications.

For steel cylinders and liners, except for designs in compliance with ISO 9809-2, the elongation shall be at least 14 %.

For aluminium alloy cylinders and liners of type 1 or type 2 construction, the elongation shall be at least 12 %.

For aluminium alloy liners of type 3 construction, the elongation shall meet the manufacturer's design specifications.

NOTE Attention is drawn to the method of measurement of elongation described in ISO 6892-1, particularly in cases where the tensile test piece is tapered, resulting in a point of fracture away from the middle of the gauge length.

#### A.2 Impact test for steel cylinders and steel liners

The impact test shall be carried out on material taken from the cylindrical part of the finished cylinder or liner on three test pieces in accordance with ISO 148-1.

The impact test pieces shall be taken in the directions given in [Table A.1](#) from the wall of the cylinder. The notch shall be perpendicular to the face of the cylinder wall. For longitudinal tests the test piece shall be machined all over (on six faces). If the wall thickness does not permit a final test piece width of 10 mm, the width shall be as near as practicable to the nominal thickness of the cylinder wall. Test pieces taken in the transverse direction shall be machined on four faces only, the inner and outer face of the cylinder wall shall be unmachined.

The impact values shall be not less than those specified in [Table A.1](#).

#### A.3 Sulfide stress cracking test for steel

Except as identified in this clause, testing shall be conducted in accordance with Method A - NACE Standard Tensile Test procedures, as described in NACE Standard TM0177. Tests shall be conducted on a minimum of three tensile specimens with a gauge diameter of 3,81 mm machined from the wall of a finished cylinder or liner. The specimens shall be placed under a constant tensile load equal to 60 % of the specified minimum yield strength of the steel, immersed in a solution of distilled water buffered with 0,5 % (mass fraction) sodium acetate trihydrate and adjusted to an initial pH of 4,0, using acetic acid. The solution shall be continuously saturated at room temperature and pressure with 0,414 kPa hydrogen sulfide (balance nitrogen). The tested specimens shall not fail within a test duration of 144 hours.

**Table A.1 — Impact test acceptance values**

Cylinder diameter, mm		> 140			≤ 140
Direction of testing		Transverse			Longitudinal
Width of test piece, mm		3 to 5	> 5 to 7,5	> 7,5 to 10	3 to 10
Test temperature, °C		- 50			- 50
Impact strength, J/cm <sup>2</sup>	Mean of three test pieces	30	35	40	60
	Individual test piece	24	28	32	48

#### A.4 Corrosion tests for aluminium

Corrosion tests for aluminium alloys shall be carried out in accordance with Annex A of ISO 7866.

#### A.5 Sustained load cracking (SLC) tests for aluminium

The resistance to SLC shall be carried out in accordance with Annex B of ISO 7866.

#### A.6 Leak-before-break (LBB) test

Three finished cylinders shall be pressure cycled between 20 bar and 1.5 × working pressure, at a rate not exceeding 10 cycles per minute in accordance with A.13.

All cylinders shall either fail by leakage or exceed 45 000 pressure cycles.

#### A.7 Extreme temperature pressure cycling

Finished cylinders, with the composite wrapping free of any protective coating, shall be cycle tested:

- a) condition for 48 h at zero pressure, 65 °C or higher, and 95 % or greater relative humidity. The intent of this requirement shall be deemed met by spraying with a fine spray or mist of water in a chamber held at 65 °C;
- b) hydrostatically pressurize for 500 cycles multiplied by the specified service life in years between 20 bar and 260 bar at 65 °C or higher, and 95 % or greater relative humidity;
- c) condition the cylinder and fluid at - 40 °C or lower as measured in the fluid and on the cylinder surface;
- d) pressurize from 20 bar to 200 bar for 500 cycles multiplied by the specified service life in years at - 40 °C or lower. Adequate recording instrumentation shall be provided to ensure the minimum temperature of the fluid is maintained during the low temperature cycling.

The pressure cycling rate of b) shall not exceed 10 cycles per minute. The pressure cycling rate of d) shall not exceed 3 cycles per minute unless a pressure transducer is installed directly within the cylinder.

During this pressure cycling, the cylinder shall show no evidence of rupture, leakage or fibre unravelling.

Following pressure cycling at extreme temperatures, cylinders shall be hydrostatically pressured to failure in accordance with A.12, and achieve a minimum burst pressure of 85 % of the minimum design burst pressure. For type 4 designs, prior to the hydrostatic burst test the cylinder shall be leak tested in accordance with A.10.

## A.8 Brinell hardness test

Hardness tests shall be carried out on the parallel wall of each cylinder or liner in accordance with ISO 6506-1 at the rate of one test per metre length of parallel wall. The test shall be carried out after the final heat treatment and the hardness values thus determined shall be in the range specified for the design.

## A.9 Coating tests

Coatings shall be evaluated using:

- a) Adhesion testing, in accordance with ASTM D3359, using method A or B, as appropriate. The coating shall exhibit an adhesion rating of either 4A or 4B, as appropriate.
- b) Flexibility, in accordance with ASTM D522-93, using test method B with a 12,7 mm (0,5 in) mandrel at the specified thickness at – 20 °C. Samples for the flexibility test shall be prepared in accordance with ASTM D522-93. There shall be no visually apparent cracks.
- c) Impact resistance, in accordance with ASTM D2794-93. The coating at room temperature shall pass a forward impact test of 18 J (13,3 ft lbs).
- d) Chemical resistance, in accordance with ASTM D1308-87, except that the tests shall be conducted using the open spot test method and 100 h exposure to a 30 % sulfuric acid solution (battery acid with a specific gravity of 1,219) and 24 h exposure to a polyalkalene glycol (e.g. brake fluid). There shall be no evidence of lifting, blistering or softening of the coating. The adhesion shall meet a rating of 3 when tested in accordance with ASTM D3359.
- e) Minimum 1 000 h exposure, using a UVA lamp in accordance with ASTM G154:2006. There shall be no evidence of blistering and adhesion shall meet a rating of 3 when tested in accordance with ASTM D3359. The maximum gloss loss shall be 20 %.
- f) Minimum 500 h exposure in accordance with ISO 9227. Undercutting shall not exceed 2 mm at the scribe mark, there shall be no evidence of blistering and adhesion shall meet a rating of 3 when tested in accordance with ASTM D3359.
- g) Resistance to chipping at room temperature, in accordance with ASTM D3170-87  
 . The coating shall have a rating of 7A or better, and there shall be no exposure of the substrate.

## A.10 Leak test

Type 4 designs shall be leak tested by (or an alternative acceptable to the Inspector in the country of use):

- a) thoroughly drying the cylinders;
- b) pressurizing the cylinders to working pressure with dry air or nitrogen containing a detectable gas such as helium.

Any leakage detected shall be cause for rejection.

Leakage is the release of gas through a crack, pore, un-bond or similar defect. Permeation through the wall in conformance to A.21 is not considered to be leakage.

## A.11 Hydrostatic pressure test

Any internal pressure applied after autofrettage, and prior to the hydrostatic pressure test, shall not exceed 90 % of the hydrostatic test pressure.

Either a volumetric expansion test or a proof pressure test shall be performed.

The volumetric expansion test shall be performed by hydrostatically pressuring the cylinder to at least 1,5 times working pressure. In no case shall the test pressure exceed the autofrettage pressure. The pressure shall be maintained for 30 s and sufficiently longer to ensure complete expansion. If the test pressure cannot be maintained due to failure of the test apparatus, it is permissible to repeat the test at a pressure increased by 7 bar. No more than 2 such repeat tests shall be carried out.

The proof pressure test shall be performed by increasing the hydrostatic pressure in the cylinder gradually and regularly until the test pressure, at least 1,5 times working pressure, is reached. The cylinder test pressure shall be maintained for at least 30 s to establish that there are no leaks.

Any cylinders not meeting the defined rejection limit for the volumetric expansion test, or leaking during the proof pressure test, shall be rejected and destroyed.

## **A.12 Hydrostatic pressure burst test**

The rate of pressurization shall not exceed 14 bar/s at pressures in excess of 80 % of the design burst pressure. If the rate of pressurization at pressures in excess of 80 % of the design burst pressure exceeds 3,5 bar/s, either the cylinder shall be located between the pressure source and the pressure measurement device, or there shall be a 5 s hold at the minimum design burst pressure, or the pressurization rate shall be less than 3,5 bar/s.

The minimum required (calculated) burst pressure shall be at least the minimum burst pressure specified for the design, and in no case less than the value necessary to meet the stress ratio requirements. The burst pressure shall be recorded. Rupture may occur in either the cylindrical region or the dome region of the cylinder.

## **A.13 Ambient temperature pressure cycling**

Pressure cycling shall be performed by:

- a) filling the cylinder to be tested with a non-corrosive fluid such as oil, inhibited water or glycol;
- b) cycling the pressure in the cylinder between 20 bar and 1,3 times working pressure at a rate not exceeding 10 cycles per minute.

The number of cycles to failure shall be reported, along with the location and description of the failure initiation, if applicable.

## **A.14 Environmental test**

### **A.14.1 General**

This test is applicable to types 2, 3, and 4 cylinders only.

### **A.14.2 Cylinder set-up and preparation**

One cylinder shall be tested, including coating if applicable.

The upper section of the cylinder shall be divided into 5 distinct areas and marked for pendulum impact preconditioning and fluid exposure (see [Figure A.1](#)). The areas shall be nominally 100 mm in diameter. While convenient for testing, the areas need not be oriented along a single line, but shall not overlap.

Although preconditioning and fluid exposure is performed on the cylindrical portion of the cylinder, all of the cylinder, including the domed sections, shall be as resistant to the exposure environments as the tested areas.

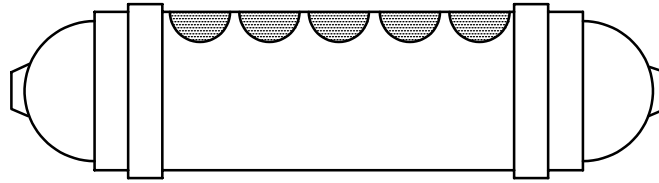

Figure A.1 — Cylinder orientation and layout of exposure areas

### A.14.3 Pendulum impact preconditioning

The impact body shall be of steel and have the shape of a pyramid with equilateral triangle faces and a square base, the summit and the edges being rounded to a radius of 3 mm. The centre of percussion of the pendulum shall coincide with the centre of gravity of the pyramid; its distance from the axis of rotation of the pendulum shall be 1 m. The total mass of the pendulum shall be such that the impact energy of the pendulum at the moment of impact is not less than 30 Nm and is as close to that value as possible.

During pendulum impact, the cylinder shall be held in position by the end bosses or by the intended mounting brackets. Each of the five areas identified in [Figure A.1](#) shall be preconditioned by impact of the pendulum body summit at the centre of the area. The cylinder shall be un-pressurized during preconditioning.

### A.14.4 Environmental fluids for exposure

Each marked area is to be exposed to one of five solutions. The five solutions are:

- a) Sulfuric acid – 19 % solution by volume in water;
- b) Sodium hydroxide – 25 % solution by weight in water;
- c) 5 % Methanol/95 % gasoline - gasoline concentration of M5 fuel meeting the requirements of ASTM D4814;
- d) Ammonium nitrate – 28 % by weight in water;
- e) Windshield washer fluid (50 % by volume solution of methyl alcohol and water).

When exposed, the test sample shall be oriented with the exposure area uppermost. A pad of glass wool approx. 0,5 mm thick and between 90 and 100 mm in diameter shall be placed on the exposure area. Apply an amount of the test fluid to the glass wool sufficient to ensure that the pad is wetted evenly across its surface and through its thickness for the duration of the test, and to ensure that the concentration of the fluid is not changed significantly during the duration of the test.

### A.14.5 Pressure cycle and pressure hold

The cylinder shall be hydraulically pressure cycled between less than or equal to 20 bar and 260 bar for a total of 3 000 cycles. The maximum pressurization rate shall be 27,5 bar per second. After pressure cycling, the cylinder shall be pressurized to 260 bar and held at that pressure a minimum of 24 hours and until the elapsed exposure time (pressure cycling and pressure hold) to the environmental fluids equals 48 hours.

### A.14.6 Acceptable result

The cylinder shall be burst tested in accordance with A.12, except that the burst pressure shall be no less than 1,8 times the working pressure.

## **A.15 Bonfire test**

### **A.15.1 General**

The bonfire test is designed to demonstrate that finished cylinders, complete with the fire protection system (cylinder valve, pressure relief devices and/or integral thermal insulation) specified in the design, will prevent the rupture of the cylinder when tested under the specified fire conditions.

Pressure relief devices shall conform to ISO 15500-13.

Precautions shall be taken during fire testing in the event that cylinder rupture occurs.

### **A.15.2 Cylinder set-up**

The cylinder shall be placed horizontally with the cylinder bottom approximately 100 mm above the fire source. Metallic shielding of a minimum 0,4 mm thickness shall be used to prevent direct flame impingement on cylinder valves, fittings, and/or pressure relief devices. The metallic shielding shall not be in direct contact with the specified fire protection system (pressure relief devices or cylinder valve).

Any failure during the test of a valve, fitting or tubing that is not part of the intended protection system for the design shall invalidate the result.

### **A.15.3 Fire source**

A uniform fire source of 1,65 m length shall provide direct flame impingement on the cylinder surface across its entire diameter width. Any fuel may be used for the fire source provided it supplies uniform heat sufficient to maintain the specified test temperatures until the cylinder is vented. The selection of a fuel should take into consideration air pollution concerns. The arrangement of the fire shall be recorded in sufficient detail to ensure that the rate of heat input to the cylinder is reproducible.

Any failure or inconsistency of the fire source during a test shall invalidate the result.

### **A.15.4 Temperature and pressure measurements**

Surface temperatures shall be monitored by at least three thermocouples located along the bottom of the cylinder and spaced not more than 0,75 m apart. Metallic shielding of a minimum 0,4 mm thickness shall be used to prevent direct flame impingement on the thermocouples. The metallic shielding shall be in contact with the thermocouples. Alternatively, thermocouples may be inserted into blocks of metal measuring less than 25 mm square. Thermocouple temperatures and the cylinder pressure shall be recorded at intervals of every 30 s or less during the test.

### **A.15.5 General test requirements**

The cylinder shall be pressurized to working pressure with natural gas and tested in the horizontal position at working pressure and, if a thermally activated PRD is not used, also at 25 % of working pressure.

Immediately following ignition, the fire shall produce flame impingement on the surface of the cylinder along the 1,65 m length of the fire source and across the cylinder diameter width.

Within 5 min of ignition the temperature on at least one thermocouple shall indicate a temperature  $\geq 590$  °C. This minimum temperature shall be maintained for the remainder of the test. If the temperature of 590 °C is not reached within 5 min but the cylinder vents within 5 min and the condition of A.15.6 is fulfilled the test shall be considered as acceptable.

For cylinders of length 1,65 m or less, the centre of the cylinder shall be positioned over the centre of the fire source.

For cylinders of length greater than 1,65 m:

- a) if the cylinder is fitted with a pressure relief device at one end, the fire source shall commence at the opposite end of the cylinder;
- b) if the cylinder is fitted with pressure relief devices at both ends, or at more than one location along the length of the cylinder, the centre of the fire source shall be centred midway between the pressure relief devices that are separated by the greatest horizontal distance;
- c) if the cylinder is additionally protected using thermal insulation, then two fire tests at service pressure shall be performed, one with the fire centred midway along the cylinder length, and the other with the fire commencing at one of the ends of a second cylinder.

### **A.15.6 Acceptable results**

The cylinder shall vent through a pressure relief device without rupturing.

### **A.16 Penetration tests**

A cylinder pressurized to working pressure + 10 bar with compressed gas shall be penetrated by an armour piercing bullet with a diameter of 7,62 mm or greater. The bullet shall completely penetrate at least one side wall of the cylinder.

For type 1 designs, the bullet shall impact the sidewall at an approximate angle of 90°. For type 2, 3 and 4 designs, the bullet shall impact the sidewall at an approximate angle of 45°.

In all cases the cylinder shall not rupture.

### **A.17 Composite flaw tolerance tests**

For type 2, 3 and 4 designs only, one finished cylinder, complete with protective coating, shall have flaws cut into the composite in the longitudinal direction. The flaws shall be greater than the visual inspection limits as specified by the manufacturer. As a minimum, one flaw shall be 25 mm long and 1,25 mm in depth, and another flaw shall be 200 mm long and 0,75 mm in depth, cut in the longitudinal direction into the cylinder sidewall.

The flawed cylinder shall be pressure cycled between 20 bar and 1,3 times working pressure at ambient temperature for the design lifetime in years  $\times$  1 000 cycles.

The cylinder shall not leak or rupture within the first 3 000 cycles, but may fail by leakage during the further design lifetime in years  $\times$  1 000 cycles (less the 3 000 cycles already performed). All cylinders that complete this test shall be destroyed.

### **A.18 High temperature creep test**

This test is required for all type 4 designs, and all type 2 and 3 designs in which the glass transition temperature of the resin matrix does not exceed 102 °C. One finished cylinder shall be pressurized to 260 bar and held at a temperature of 100 °C for not less than 200 h. The cylinder shall then meet the requirements of the volumetric expansion test (A.11), the leak test (A.10) and the hydrostatic pressure burst test (A.12).

### **A.19 Accelerated stress rupture test**

For type 2, 3 and 4 designs only, one cylinder shall be hydrostatically pressurized to 260 bar at 65 °C. The cylinder shall be held at this pressure and temperature for 1 000 h. The cylinder shall then be pressured to burst in accordance with the procedure described in A.12, except that the burst pressure shall exceed 85 % of the minimum design burst pressure.

## A.20 Impact damage test

For type 3 and type 4 designs, one or more finished cylinders (including end caps that are part of the design) shall be tested at ambient temperature without internal pressurization or attached valves. The surface onto which the cylinders are dropped shall be a smooth, horizontal concrete pad or flooring. One cylinder shall be dropped in a horizontal position with the bottom 1,8 m above the surface on to which it is dropped. One cylinder shall be dropped vertically on each end at a sufficient height above the floor or pad so that the potential energy is 488 J, but in no case shall the height of the lower end be greater than 1,8 m. One cylinder shall be dropped at a 45° angle on to a dome, from a height such that the centre of gravity is at 1,8 m; however, if the lower end is closer to the ground than 0,6 m, the drop angle shall be changed to maintain a minimum height of 0,6 m and a centre of gravity of 1,8 m.

The cylinders shall be allowed to bounce on the concrete pad or flooring after the initial impact. No attempt shall be made to prevent this secondary impacting, but the cylinder may be prevented from toppling during the vertical drop tests.

Following the drop impact, the cylinders shall be pressure cycled between 20 bar and 1,3 times the working pressure at ambient temperature for the design lifetime in years  $\times$  1 000 cycles.

The cylinder shall not leak or rupture within the first 3 000 cycles, but may fail only by leakage, during the further design lifetime in years  $\times$  1 000 cycles (less the 3 000 cycles already performed). All cylinders that complete this test shall be destroyed.

## A.21 Permeation test

This test is only required on type 4 designs. One finished cylinder shall be filled with compressed natural gas to working pressure, placed in an enclosed sealed chamber at ambient temperature, and monitored for leakage for up to 500 h, to establish a steady-state permeation rate. Examples of measurement techniques include gas chromatography, mass spectrometry, and weight loss. The permeation rate shall be less than 0,25 normal cc of natural gas per hour per litre water capacity of the cylinder.

## A.22 Tensile properties of plastics

The tensile yield strength and ultimate elongation of plastic liner material shall be determined at  $-50\text{ }^{\circ}\text{C}$  in accordance with ISO 527-2.

The test results shall demonstrate the ductile properties of the plastic liner material at temperatures of  $-50\text{ }^{\circ}\text{C}$  or lower by meeting the values specified by the manufacturer.

## A.23 Softening temperature of plastics

Polymeric materials from finished liners shall be tested in accordance with ISO 306.

The softening temperature shall be at least  $100\text{ }^{\circ}\text{C}$ .

## A.24 Coating batch tests

### A.24.1 Coating thickness

The thickness of the coating shall be measured in accordance with ISO 2808 and shall meet the requirements of the design.

### A.24.2 Coating adhesion

The coating adhesion strength shall be measured in accordance with ASTM 3359, using Method A or B as appropriate, and shall have a minimum rating of 4 when measured using either test Method A or B, as appropriate.



### **A.25 Boss torque test**

The body of the cylinder shall be restrained against rotation and a torque of twice the valve or PRD installation torque specified by the manufacturer shall be applied to each end boss of the cylinder. The torque shall be applied first in the direction of tightening a threaded connection, then in the un-tightening direction, and finally again in the tightening direction.

The cylinder shall then be subjected to a leak test in accordance with A.10.

### **A.26 Resin shear strength**

Resin materials shall be tested on a sample coupon representative of the composite overwrap in accordance with ISO 14130, or an equivalent standard acceptable to the Inspector in the country of use. Following 24 h boiling in water, the composite shall have a minimum shear strength of 13,8 MPa.

### **A.27 Natural gas cycling test**

Special consideration shall be given to safety when conducting this test. Prior to conducting this test, cylinders of the same design shall have successfully passed the test requirements of A.10 (leak test), A.12 (hydrostatic pressure burst test), A.13 (ambient temperature pressure cycling test) and A.21 (permeation test).

One finished type 4 cylinder shall be pressure cycled using compressed natural gas between less than 20 bar and working pressure for 1 000 cycles. The filling time shall be 5 min maximum, to simulate commercial filling conditions. Unless otherwise specified by the manufacturer, care should be taken to ensure that temperatures during venting do not exceed the defined service conditions.

The cylinder shall be leak tested in accordance with A.10. Following completion of the natural gas cycling, the cylinder shall be sectioned and the liner and liner/end boss interface inspected for evidence of deterioration, such as fatigue cracking or electrostatic discharge, that could lead to failure within the design life of the cylinder.

Alternatively, to eliminate the need for sectioning and inspection, the cylinder may be natural gas cycle tested for 1 000 cycles times its design life in years without leaking.

### **A.28 Torque test**

The body of the cylinder shall be held to prevent it rotating. The cylinder shall be fitted with a corresponding valve and tightened to 150 % of the maximum torque as recommended by the manufacturer. The parameters that shall be monitored and recorded are:

- a) type of valve material;
- b) valving procedure;
- c) applied torque.

The cylinder neck or boss and threads shall remain within drawing and gauge tolerance.

## Annex B (normative)

### Ultrasonic examination

#### B.1 Introduction

This annex is based on techniques used by cylinder manufacturers. Other techniques of ultrasonic inspection may be used, provided that these have been demonstrated to be suitable for the manufacturing method.

#### B.2 General requirements

The ultrasonic examination equipment shall be capable of at least detecting the reference standard notches as described in B.3.2. It shall be serviced regularly in accordance with the manufacturer's operating instructions to ensure that its accuracy is maintained. Inspection records and approval certificates for the equipment shall be maintained.

The operation of the examination equipment shall be by trained personnel and supervised by qualified and experienced personnel certified to level 2 of ISO 9712.

The outer and inner surfaces of any cylinder that is to be examined ultrasonically shall be in a condition suitable for an accurate and reproducible examination.

For flaw detection, the pulse echo system shall be used. For thickness measurement, either the resonance method or the pulse echo system shall be used. Either contact or immersion techniques of examination shall be used.

A coupling method that ensures adequate transmission of ultrasonic energy between the examination probe and the cylinder shall be used.

#### B.3 Flaw detection of the cylindrical parts

##### B.3.1 Procedure

The cylinders to be inspected and the search unit shall have a rotating motion and translation relative to one another such that a helical scan of the cylinder is described. The velocity of rotation and translation shall be constant to within  $\pm 10\%$ . The pitch of the helix shall be less than the width covered by the probe (the overlap shall be at least 10%) and be related to the effective beam width such as to ensure 100% coverage at the velocity of rotation and translation used during the calibration procedure.

An alternative scanning method may be used for transverse defect detection, in which the scanning or relative movement of the probes and the work piece is longitudinal, the sweeping motion being such as to ensure a 100% surface coverage with about 10% overlap of the sweeps.

The cylinder wall shall be examined for longitudinal defects with the ultrasonic energy transmitted in both circumferential directions and for transverse defects in both longitudinal directions.

In this case, or when optional examination is carried out on the transition areas between the wall and neck and/or wall and base, this may be conducted manually if not carried out automatically.

The effectiveness of the equipment shall be periodically checked by passing a reference standard through the examination procedure. This check shall be carried out at least at the beginning and end of each shift. If during this check the presence of the appropriate reference notch is not detected, then all

cylinders examined subsequent to the last acceptance check shall be reexamined after the equipment has been reset.

### B.3.2 Reference standard

A reference standard of convenient length shall be prepared from a cylinder of similar diameter and wall thickness range, and from material with the same acoustic characteristics and surface finish as the cylinder to be inspected.

The reference standard shall be free from discontinuities that may interfere with the detection of the reference notches.

Reference notches, both longitudinal and transverse, shall be machined on the outer and inner surface of the standard. The notches shall be separated such that each notch can be clearly identified.

Dimensions and shape of notches are of crucial importance for the adjustment of the equipment (see [Figures B.1](#) and [B.2](#)).

Notches shall:

- a) have a length ( $E$ ) no greater than 50 mm;
- b) have a width ( $W$ ) no greater than twice the nominal depth ( $T$ ). However, where this condition cannot be met, a maximum width of 1 mm is acceptable;
- c) have a depth ( $T$ ) of  $(5 \pm 0,75)$  % of the nominal thickness ( $S$ ) with a minimum of 0,2 mm and a maximum of 1 mm, over the full length of the notch. Run outs at each end are permissible;
- d) shall be sharp edged at its intersection with the surface of the cylinder wall. The cross section of the notch shall be rectangular except where spark erosion machining methods are used; when it is acknowledged that the bottom of the notch will be rounded;
- e) demonstrate the shape and dimensions of the notch by an appropriate method.

## B.4 Calibration of equipment

Using the reference standard described in B.3.2, the equipment shall be adjusted to produce clearly identifiable indications from inner and outer reference notches. The amplitude of the indications shall be as near equal as possible. The indication of smallest amplitude shall be used as the rejection level and for setting visual, audible, recording or sorting devices. The equipment shall be calibrated with the reference standard or probe, or both, moving in the same manner, in the same direction and at the same speed as will be used during the inspection of the cylinder. All visual, audible, recording or sorting devices shall operate satisfactorily at the examination speed.

## B.5 Wall thickness measurement

If the measurement of the wall thickness is not carried out at another stage of production, the cylindrical part shall be 100 % examined to ensure that the thickness is not less than the guaranteed minimum value.

## B.6 Interpretation of results

Cylinders with indications that are equal to or greater than the lowest of the indications from the reference notches shall be withdrawn. Surface defects may be removed; after removal the cylinders shall be re-subjected to ultrasonic flaw detection and thickness measurement.

Any cylinder that is shown to be below the guaranteed minimum wall thickness shall be rejected.

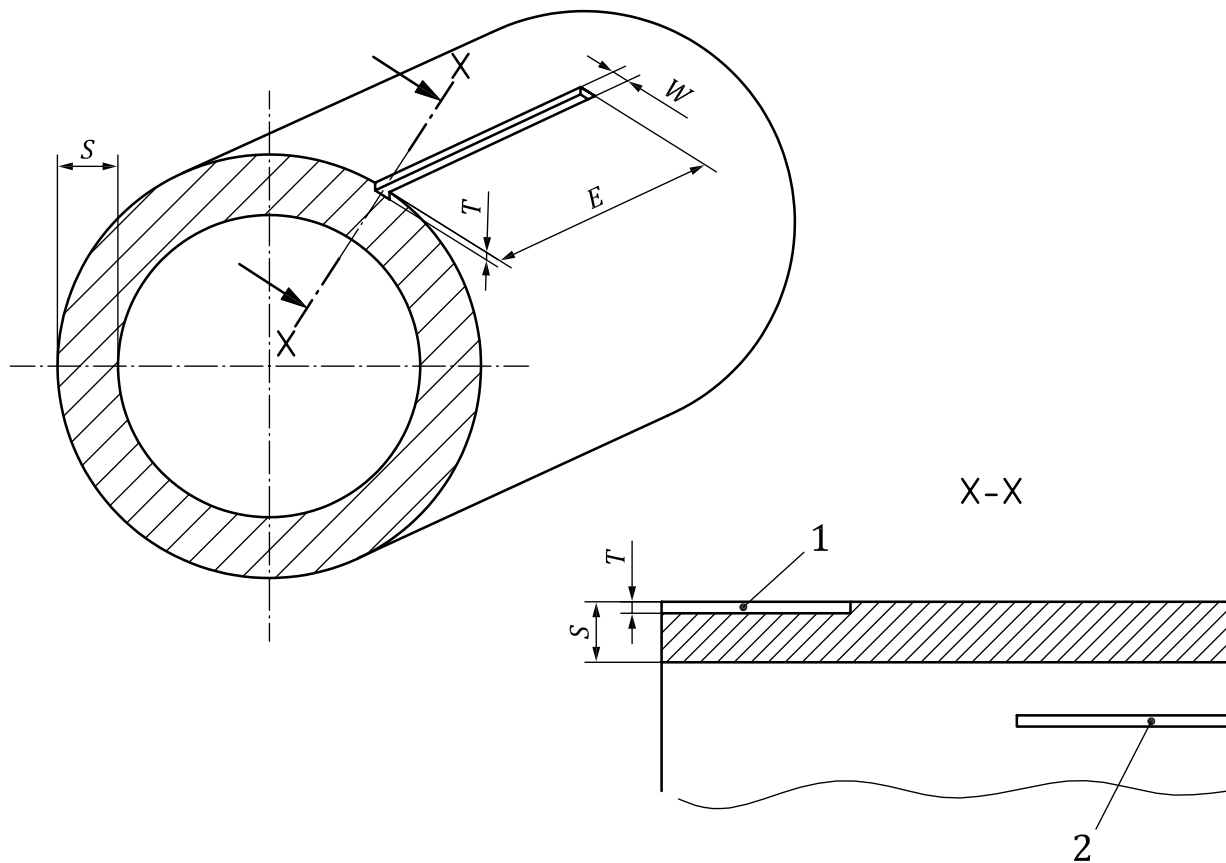

**Key**

- 1 external reference notch
- 2 internal reference notch

NOTE 1  $T = (5 \pm 0,75) \%S$  but  $0,2 \text{ mm} \leq T \leq 1 \text{ mm}$

NOTE 2  $W \leq 2T$ , but if not possible then  $W \leq 1 \text{ mm}$

NOTE 3  $E \leq 50 \text{ mm}$

**Figure B.1 — Design details and dimensions of the reference notches for longitudinal defects**

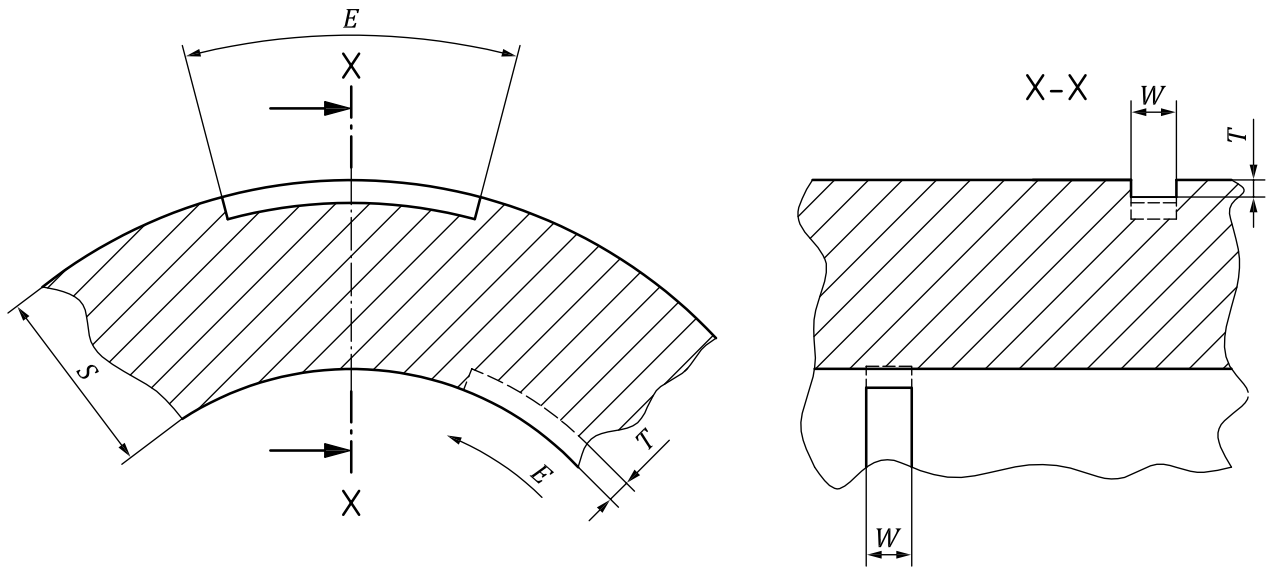

NOTE 1  $T = (5 \pm 0,75) \%S$  but  $0,2 \text{ mm} \leq T \leq 1 \text{ mm}$

NOTE 2  $W \leq 2T$ , but if not possible then  $W \leq 1 \text{ mm}$

NOTE 3  $E \leq 50 \text{ mm}$

**Figure B.2 — Schematic representation of the reference notches for circumferential defects**

## B.7 Certification

The ultrasonic examination shall be certified by the cylinder manufacturer.

Every cylinder, which has passed the ultrasonic examination in accordance with this specification shall be stamp-marked with the symbol "UT", or with the symbol shown as an example in [Figure B.3](#) (where the characters "XY" represent the manufacturer's logo or symbol).

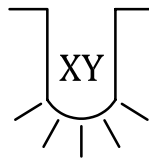

**Figure B.3 — UT symbol**

## **Annex C** (informative)

### **Non-destructive examination (NDE) defect size by flawed cylinder cycling**

The NDE defect size for type 1, 2 and 3 designs can be determined by:

- a) for type 1 designs having a fatigue sensitive site in the cylindrical part, introduce external flaws on to the side wall;
- b) for type 1 designs having the fatigue sensitive site outside the side wall, and for type 2 and 3 designs, introduce internal flaws. Internal flaws may be machined prior to the heat treatment and closing of the end of the cylinder;
- c) size these artificial defects to exceed the defect length and depth detection capability of the NDE inspection method;
- d) pressure cycle to failure three cylinders containing these artificial defects in accordance with the test method specified in A.13.

If the cylinders do not leak or rupture in less than 1 000 cycles multiplied by the specified service life in years, then the allowable defect size for NDE is equal to or less than the artificial flaw size at that location.

## Annex D (informative)

### Report forms

#### D.1 General

This annex provides guidance on the range of information to be included in the file of technical documentation associated with cylinder approval. Examples of suitable formats are provided for Form 1 and Form 7. Forms 2 to 6 should be developed by the manufacturer to fully identify the cylinders and requirements. Each report should be signed by the authorized inspection body and the manufacturer.

#### D.2 List of forms

The documentation should at least include:

- Form 1) Report of Manufacture and Certificate of Conformance — to be clear and legible. An example of a suitable format is given in [Figure D.1](#).
- Form 2) Report of Chemical Analysis of Material for Metallic Cylinders, Liners or Bosses — to include essential elements, identification, etc.
- Form 3) Report of Mechanical Properties of Material for Metallic Cylinders and Liners — to report all tests required by this International Standard.
- Form 4) Report of Physical and Mechanical Properties of Materials for Non-Metallic Liners — to report all tests and information required in this International Standard.
- Form 5) Report of Composite Analysis — to report all tests and data required in this International Standard.
- Form 6) Report of Hydrostatic Tests, Pressure Cycling and Burst Tests — to report test and data required in this International Standard.
- Form 7) Type Approval Certificate — an example of a suitable format is given in [Figure D.2](#).

**ISO 11439:2013(E)**

Manufactured by: .....

Located at:.....

Authority registration number: .....

Manufacturer's mark and number: .....

Serial number: ..... to ..... inclusive

Cylinder description: .....

SIZE: Outside diameter ..... mm; Length ..... mm

Marks stamped on shoulder or on labels of the cylinder are:

- a) "CNG ONLY": .....
- b) "DO NOT USE AFTER": .....
- c) Manufacturer's mark: .....
- d) Serial or part number:.....
- e) Working pressure in bar: ..... bar
- f) ISO Standard:.....
- g) Fire protection: ..... Type
- h) Date of original test (month and year): ..... - .....
- i) Tare mass of empty cylinder: ..... Kg
- j) Authorized inspection body or Inspector's mark:.....
- k) Water capacity in litres (l):.....
- l) Test pressure in bar:.....
- m) Any special instructions: .....

Each cylinder was made in conformance to all requirements of ISO Standard ..... and in accordance with the cylinder description. Required reports of test results are attached.

I hereby certify that all these test results proved satisfactory in every way and are in conformance to the ISO standard requirements for the ISO type listed. ....

Comments: .....

Authorized body or inspection agency: .....

Inspector's signature: .....

Manufacturer's signature: .....

Place ..... Date.....

**Figure D.1 — Example format for Form 1: Report of manufacture and Certification of conformance**



**TYPE APPROVAL CERTIFICATE**

Issued by: .....

(Authorized inspection body)

.....  
 applying ISO Standard .....

Concerning

.....  
 (TYPE OF CYLINDER)

Approval No. .... Date .....

Type of cylinder: .....

(Description of the family of cylinders (Drawing No.) which has received type approval)

Service pressure: ..... bar

Manufacturer or agent .....

(Name and address of manufacturer or agent)

All information may be obtained from .....

(Name and address of approving body)

.....  
 Date ..... Place .....

.....  
 (Signature of Inspector)

**Figure D.2 — Example format for Form 7: Type approval certificate**

## Annex E (informative)

### Standard working pressures

The pressure most commonly used outside of North America is a settled pressure of 200 bar at a temperature of 15 °C. In North America, two settled pressures are commonly used, 3 000 psi and 3 600 psi, at a settled temperature of 70 °F.

Considering that  $\text{Pressure} \times \text{Volume} = z \text{ (compressibility factor)} \times R \text{ (gas constant)} \times \text{Temperature}$ , the equivalents for a 200 bar system are:

Specification	This Standard	ANSI/CSA NGV2
Working pressure	200 bar (2 900 psi)	3 000 psi (207 bar)
Reference temperature	15 °C (59 °F)	70 °F (21 °C)
Maximum filling pressure	260 bar (3 770 psi)	3 750 psi (259 bar)
Maximum filling pressure/working pressure	1,3	1,25

Note that 200 bar (2 900 psi) at 15 °C is equivalent to 207 bar (3 000 psi) at 21 °C. However, since both standards agree that the maximum filling pressure is about 260 bar, this means that ISO 11439 designs have to be tested at a factor of 1,3 times working pressure, while NGV2 designs have to be tested at a 1,25 times factor. Thus while cylinders made to the two standards are of the same basic design, the use of a different reference temperature between the two standards can cause differences in testing requirements, and in apparent stress ratios. For example, ISO 11439 requires a stress ratio of 2,35 for carbon fibre, while NGV2 has a 2,25 value. Both standards require the same minimum burst strength of about 470 bar, but because of the different working pressure “starting points” (200 bar vs. 207 bar), the ISO design appears to require a higher stress ratio to achieve that minimum burst value.

The other standard pressure in North America, 3 600 psi, is 20 percent higher than 3 000 psi. It is logical to use this as another standard pressure, taking advantage of equipment already developed, including valves and pressure relief devices, fill nozzles, and refuelling systems. This would make the equivalent International pressure 240 bar, 20 percent higher than the current baseline 200 bar. The equivalents for a 240 bar system are:

Specification	This Standard	ANSI/CSA NGV2
Working pressure	240 bar (3 480 psi)	3 600 psi (248 bar)
Reference temperature	15 °C (59 °F)	70 °F (21 °C)
Maximum pressure	312 bar (4 524 psi)	4 500 psi (310 bar)
Maximum filling pressure/working pressure	1,3	1,25

## Annex F (informative)

### Verification of stress ratios using strain gauges

This annex describes a procedure that may be used to verify stress ratios by use of strain gauges.

- a) The stress-strain relationship for fibres is always elastic, therefore, stress ratios and strain ratios are equal.
- b) High elongation strain gauges are required.
- c) Strain gauges should be orientated in the direction of the fibres on which they are mounted (i.e. with hoop fibre on the outside of the cylinder, mount gauges in the hoop direction).
- d) Method 1 (applies to cylinders that do not use high tension winding)
  - 1) Prior to autofrettage, apply strain gauges and calibrate.
  - 2) Measure strains at autofrettage, at zero pressure after autofrettage and at working and minimum burst pressure.
  - 3) Confirm that the strain at burst pressure divided by the strain at working pressure meets the stress ratio requirements. For hybrid construction, the strain at operating pressure is compared with the rupture strain of cylinders reinforced with a single fibre type.
- e) Method 2 (applies to all cylinders)
  - 1) At zero pressure after winding and autofrettage, apply strain gauges and calibrate.
  - 2) Measure strains at zero, working and minimum burst pressures.
  - 3) At zero pressure, after strain measurements have been taken at the working and minimum burst pressures, and with strain gauges monitored, cut the cylinder section apart so that the region containing the strain gauge is approximately 125 mm long. Remove the liner without damaging the composite. Measure the strains after the liner is removed.
  - 4) Adjust the strain readings at zero, operating, and minimum burst pressures by the amount of strain measured at zero pressure with and without the liner.
  - 5) Confirm that the strain at burst pressure divided by the strain at working pressure meets the stress ratio requirements. For hybrid construction, the strain at operating pressure is compared with the rupture strain of cylinders reinforced with a single fibre type.

## **Annex G** **(informative)**

### **Manufacturer's instructions for handling, use and inspection of cylinders**

#### **G.1 General**

The primary function of the manufacturer's instructions is to provide guidance to the cylinder purchaser, distributor, installer and user for the safe use of the cylinder over its intended service life.

#### **G.2 Distribution**

The manufacturer should advise the purchaser to supply these instructions to all parties involved in the distribution, handling, installation and use of the cylinders.

The document may be reproduced to provide sufficient copies for this purpose; however, it should be marked to provide reference to the cylinders being delivered.

#### **G.3 Reference to existing codes, standards and regulations**

Specific instructions may be stated by reference to national or recognized codes, standards and regulations.

#### **G.4 Cylinder handling**

Handling procedures should be described which would ensure that the cylinders will not suffer unacceptable damage or contamination during handling.

#### **G.5 Installation**

Installation instructions should be provided which would ensure that the cylinders do not suffer unacceptable damage during installation and during normal operation over the intended service life.

Where the installation is specified by the manufacturer, the instructions should, where relevant, contain details such as mounting design, the use of resilient gasket materials, the correct tightening torques and avoidance of direct exposure of the cylinder to the environment, chemicals and mechanical contacts. Cylinder locations and mountings should conform to recognized installation standards.

Where the installation is not specified by the manufacturer, the manufacturer should draw the purchaser's attention to possible long-term impacts of the vehicle mounting system, e.g. vehicle body movements and cylinder expansion/contraction under the pressure and temperature conditions of service.

Where applicable, the purchaser's attention should be drawn to the need to provide installations such that liquids or solids cannot be collected to cause cylinder material damage.

The correct pressure relief device to be fitted should be specified.

Cylinder valves, pressure relief devices and connections should be protected against breakage in a collision. If this protection is mounted on the cylinder, the design and method of attachment should be approved by the cylinder manufacturer. Factors to be considered include the ability of the cylinder to support any transferred impact loads and the effect of localized strains on cylinder stresses and fatigue life.

## G.6 Use of cylinders

The manufacturer should draw the purchaser's attention to the intended service conditions specified in this International Standard, in particular the cylinder's permissible number of pressure cycles, its life in years, the gas quality limits and the permissible maximum pressures.

## G.7 In-service inspection

The manufacturer should clearly specify the user's obligation to observe the required cylinder inspection requirements (e.g. re-inspection interval, by authorized personnel). This information should be in agreement with the design approval requirements, and should cover:

### a) Periodic re-qualification

Inspection and/or testing is required to be performed in accordance with the relevant regulations of the country(ies) where the cylinders are used.

Recommendations for periodic re-qualification by visual inspection or testing during the service life should be provided by the cylinder manufacturer on the basis of use under service conditions specified herein. Each cylinder should be visually inspected at least every 48 months, and at the time of any re-installation, for external damage and deterioration, including under the support straps. The visual inspection should be performed by a competent agency approved or recognized by the regulatory authority, in accordance with the manufacturer's specifications.

Cylinders without labels or stamps containing mandatory information, or with labels or stamps containing mandatory information that is illegible in any way should be removed from service. If the cylinder can be positively identified by manufacturer and serial number a replacement label or stamping may be applied, allowing the cylinder to remain in service.

### b) Cylinders involved in collisions

Cylinders that have been involved in a vehicle collision should be re-inspected by an authorized inspection agency. Cylinders that have not experienced any impact damage from the collision may be returned to service, otherwise the cylinder should be returned to the manufacturer for evaluation.

### c) Cylinders involved in fires

Cylinders that have been subject to the action of fire should be re-inspected by an authorized inspection agency, or condemned and removed from service.

