

INTERNATIONAL STANDARD

ISO 11432

Second edition
2005-07-01

Building construction — Sealants — Determination of resistance to compression

*Construction immobilière — Mastics — Détermination de la résistance à
la compression des mastics*



Reference number
ISO 11432:2005(E)

© ISO 2005

PDF disclaimer

This PDF file may contain embedded typefaces. In accordance with Adobe's licensing policy, this file may be printed or viewed but shall not be edited unless the typefaces which are embedded are licensed to and installed on the computer performing the editing. In downloading this file, parties accept therein the responsibility of not infringing Adobe's licensing policy. The ISO Central Secretariat accepts no liability in this area.

Adobe is a trademark of Adobe Systems Incorporated.

Details of the software products used to create this PDF file can be found in the General Info relative to the file; the PDF-creation parameters were optimized for printing. Every care has been taken to ensure that the file is suitable for use by ISO member bodies. In the unlikely event that a problem relating to it is found, please inform the Central Secretariat at the address given below.

© ISO 2005

All rights reserved. Unless otherwise specified, no part of this publication may be reproduced or utilized in any form or by any means, electronic or mechanical, including photocopying and microfilm, without permission in writing from either ISO at the address below or ISO's member body in the country of the requester.

ISO copyright office
Case postale 56 • CH-1211 Geneva 20
Tel. + 41 22 749 01 11
Fax + 41 22 749 09 47
E-mail copyright@iso.org
Web www.iso.org

Published in Switzerland

Contents

Page

Foreword.....	iv
1 Scope	1
2 Normative references	1
3 Terms and definitions.....	1
4 Principle.....	1
5 Apparatus	1
6 Preparation of test specimens	2
7 Conditioning of test specimens	2
8 Test procedure	3
9 Expression of results	3
10 Test report	3

Foreword

ISO (the International Organization for Standardization) is a worldwide federation of national standards bodies (ISO member bodies). The work of preparing International Standards is normally carried out through ISO technical committees. Each member body interested in a subject for which a technical committee has been established has the right to be represented on that committee. International organizations, governmental and non-governmental, in liaison with ISO, also take part in the work. ISO collaborates closely with the International Electrotechnical Commission (IEC) on all matters of electrotechnical standardization.

International Standards are drafted in accordance with the rules given in the ISO/IEC Directives, Part 2.

The main task of technical committees is to prepare International Standards. Draft International Standards adopted by the technical committees are circulated to the member bodies for voting. Publication as an International Standard requires approval by at least 75 % of the member bodies casting a vote.

Attention is drawn to the possibility that some of the elements of this document may be the subject of patent rights. ISO shall not be held responsible for identifying any or all such patent rights.

ISO 11432 was prepared by Technical Committee ISO/TC 59, *Building construction*, Subcommittee SC 8, *Joining products*.

This second edition cancels and replaces the first edition (ISO 11432:1993), Clauses 5, 6 and 7 of which have been technically revised.

Building construction — Sealants — Determination of resistance to compression

1 Scope

This International Standard specifies a method for the determination of the resistance to compression of sealants used in joints in building construction.

2 Normative references

The following referenced documents are indispensable for the application of this document. For dated references, only the edition cited applies. For undated references, the latest edition of the referenced document (including any amendments) applies.

ISO 6927, *Building construction — Jointing products — Sealants — Vocabulary*

ISO 13640, *Building construction — Jointing products — Specifications for test substrates*

3 Terms and definitions

For the purposes of this document, the definitions given in ISO 6927 apply.

4 Principle

Test specimens, in which the sealant to be tested is adhered to two parallel substrate surfaces, are compressed by a defined percentage of the original width and the force recorded.

5 Apparatus

5.1 Substrate materials, used for the preparation of test specimens, are defined in ISO 13640, *Specification for test substrates*. The materials shall be selected from mortar and/or anodized aluminium and/or glass. Other substrate materials may be used as agreed by the parties concerned. For each test specimen, two substrate pieces of the same material are required; with dimensions as shown in Figures 1 and 2. Test substrates of other dimensions may be used, but then the dimensions of the sealant bead and the area of adhesion shall be the same as those shown in Figures 1 and 2.

5.2 Spacers, for the preparation of the test specimens, of cross-sections (12 mm × 12 mm) with anti-adherent surface.

5.3 Anti-adherent substrate, for the preparation of test specimens, e.g. polyethylene (PE) film, preferably according to the advice of the sealant manufacturer.

5.4 Ventilated convection-type oven, capable of operating at (70 ± 2) °C for conditioning according to method B.

5.5 Container, for water immersion of the specimen for conditioning according to method B.

5.6 Tensile test machine, capable of compressing the test specimens at a rate of $(5,5 \pm 0,7)$ mm/min.

6 Preparation of test specimens

The sealant and the test substrate shall be brought to (23 ± 2) °C. For each substrate material, three test specimens shall be prepared.

For each test specimen, two substrates (5.1) and two spacers (5.2) shall be assembled (see Figures 1 and 2) and set on the anti-adherent substrate (5.3).

The instructions of the sealant manufacturer shall be followed concerning, for instance, whether a primer is to be used and the mixing procedure for multi-component sealants. The hollow volume formed by the substrates shall be filled with the sealant.

The following precautions shall be taken:

- a) the formation of air bubbles shall be avoided;
- b) the sealant shall be pressed to the contact surfaces of the substrates;
- c) the sealant surface shall be trimmed so that it is flush with the faces of the substrates and the spacers.

The test specimens shall be set on the edge of one of the supports and the anti-adherent substrate shall be removed as soon as possible. The test specimens shall be kept in this position to allow curing or optimum drying of the sealant.

The spacers shall be maintained in place during conditioning.

7 Conditioning of test specimens

7.1 General

The test specimens shall be conditioned either according to method A (see 7.2) or method B (see 7.3).

7.2 Conditioning method A

The test specimens shall be conditioned for 28 days at (23 ± 2) °C and (50 ± 5) % relative humidity.

7.3 Conditioning method B

First the test specimens shall be conditioned according to method A and subsequently subjected three times to the following storage cycle:

- a) three days in the oven (5.4) at (70 ± 2) °C;
- b) one day in distilled water (5.5) at (23 ± 2) °C;
- c) two days in the oven (5.4) at (70 ± 2) °C;
- d) one day in distilled water (5.5) at (23 ± 2) °C.

This cycle may be carried out alternatively in the sequence: c), d), a), b).

After conditioning according to method B, the test specimens shall be stored for a further period of 24 h at (23 ± 2) °C and (50 ± 5) % relative humidity before testing.

NOTE Conditioning method B is a normal conditioning procedure using the influence of heat and water. It is not intended to give information on the durability of the sealant.

8 Test procedure

The test shall be carried out at $(23 \pm 2) ^\circ\text{C}$ and $(50 \pm 5) \%$ relative humidity. The spacers (5.2) shall be removed. The test specimens shall be placed in the tensile test machine (5.6) and compressed at a rate of $(5,5 \pm 0,7) \text{ mm/min}$ to 75 % or 80 % of the initial width, or by any other percentage as agreed by the parties concerned.

The following table gives the correspondence in millimetres of the percentage compression for a test specimen of 12 mm initial width.

**Table 1 — Correspondence of compression values
original width 12 mm**

Compressed width relative to the original width %	Compression %	Width after compression mm
75	25	9,0
80	20	9,6

The force, expressed in newtons, required for the appropriate compression shall be recorded.

9 Expression of results

For each test specimen, the secant compression modulus shall be calculated, for the chosen compression amplitude, rounded to $0,01 \text{ N/mm}^2$, using the equation:

$$\text{Secant compression modulus} = \text{Force at chosen compression (expressed in N)} / \text{initial cross-section area (expressed in mm}^2\text{)}$$

The arithmetic mean of the three secant compression modulus values shall be calculated, rounded to $0,01 \text{ N/mm}^2$.

10 Test report

The test report shall contain the following information:

- a) the test laboratory's name and the date of testing;
- b) a reference to this International Standard;
- c) name, type (chemical family) and colour of sealant;
- d) batch of sealant from which the test specimens were produced;
- e) substrate material used;
- f) the primer used, if applicable;
- g) the method of conditioning (see Clause 7);
- h) the percentage compression (see Clause 8);
- i) the secant compression modulus of each test specimen (N/mm^2);
- j) the arithmetic mean of the three secant compression modulus;
- k) any deviations from this International Standard.

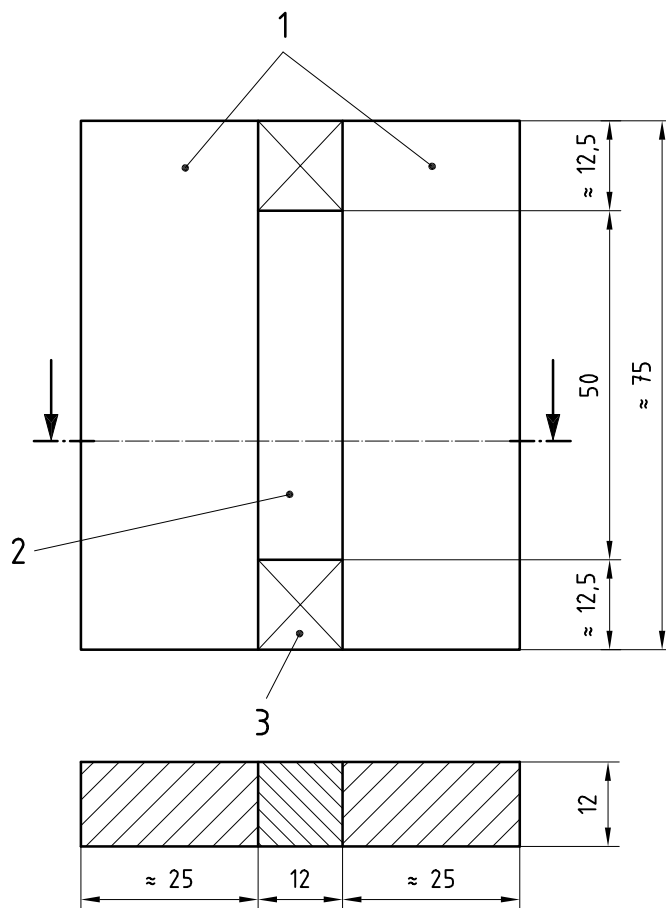

Key

- 1 mortar substrates
- 2 sealant
- 3 spacers (5.2)

Figure 1 — Test specimens with mortar substrates

Dimensions in millimetres

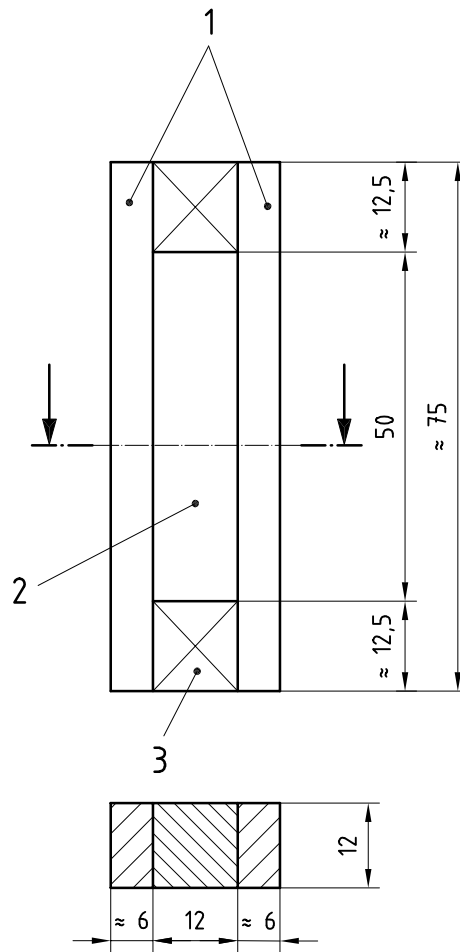

Key

- 1 anodized aluminium or glass substrates
- 2 sealant
- 3 spacers (5.2)

Figure 2 — Test specimens with anodized aluminium or glass substrates

.....

ICS 91.100.50

Price based on 5 pages