

---

---

**Building construction — Jointing  
products — Determination of  
adhesion/cohesion properties of sealants  
after exposure to heat, water and artificial  
light through glass**

*Construction immobilière — Produits pour joints — Détermination des  
propriétés d'adhésivité/cohésion des mastics après exposition à la chaleur,  
à l'eau et à la lumière artificielle à travers le verre*



Reference number  
ISO 11431:2002(E)

© ISO 2002

**PDF disclaimer**

This PDF file may contain embedded typefaces. In accordance with Adobe's licensing policy, this file may be printed or viewed but shall not be edited unless the typefaces which are embedded are licensed to and installed on the computer performing the editing. In downloading this file, parties accept therein the responsibility of not infringing Adobe's licensing policy. The ISO Central Secretariat accepts no liability in this area.

Adobe is a trademark of Adobe Systems Incorporated.

Details of the software products used to create this PDF file can be found in the General Info relative to the file; the PDF-creation parameters were optimized for printing. Every care has been taken to ensure that the file is suitable for use by ISO member bodies. In the unlikely event that a problem relating to it is found, please inform the Central Secretariat at the address given below.

© ISO 2002

All rights reserved. Unless otherwise specified, no part of this publication may be reproduced or utilized in any form or by any means, electronic or mechanical, including photocopying and microfilm, without permission in writing from either ISO at the address below or ISO's member body in the country of the requester.

ISO copyright office  
Case postale 56 • CH-1211 Geneva 20  
Tel. + 41 22 749 01 11  
Fax + 41 22 749 09 47  
E-mail [copyright@iso.ch](mailto:copyright@iso.ch)  
Web [www.iso.ch](http://www.iso.ch)

Printed in Switzerland

## Foreword

ISO (the International Organization for Standardization) is a worldwide federation of national standards bodies (ISO member bodies). The work of preparing International Standards is normally carried out through ISO technical committees. Each member body interested in a subject for which a technical committee has been established has the right to be represented on that committee. International organizations, governmental and non-governmental, in liaison with ISO, also take part in the work. ISO collaborates closely with the International Electrotechnical Commission (IEC) on all matters of electrotechnical standardization.

International Standards are drafted in accordance with the rules given in the ISO/IEC Directives, Part 3.

Draft International Standards adopted by the technical committees are circulated to the member bodies for voting. Publication as an International Standard requires approval by at least 75 % of the member bodies casting a vote.

Attention is drawn to the possibility that some of the elements of this International Standard may be the subject of patent rights. ISO shall not be held responsible for identifying any or all such patent rights.

International Standard ISO 11431 was prepared by Technical Committee ISO/TC 59, *Building construction*, Subcommittee SC 8, *Joining products*.

This second edition cancels and replaces the first edition (ISO 11431:1993), which has been technically revised.



# Building construction — Jointing products — Determination of adhesion/cohesion properties of sealants after exposure to heat, water and artificial light through glass

## 1 Scope

This International Standard specifies a method for the determination of the adhesion/cohesion properties of sealants after cyclic exposure to heat and artificial light followed by a period of exposure to water at a defined temperature.

NOTE The cyclic exposure of the test specimens to water and to radiation and heat is meant to simulate the exposure of sealants in service to natural weather conditions. The acceleration factor in comparison with the real situation is unknown. The intention is not to receive durability data for the sealants under evaluation but to ensure a minimum performance in glazing applications.

## 2 Normative references

The following normative documents contain provisions which, through reference in this text, constitute provisions of this International Standard. For dated references, subsequent amendments to, or revisions of, any of these publications do not apply. However, parties to agreements based on this International Standard are encouraged to investigate the possibility of applying the most recent editions of the normative documents indicated below. For undated references, the latest edition of the normative document referred to applies. Members of ISO and IEC maintain registers of currently valid International Standards.

ISO 4892-1:1999, *Plastics — Methods of exposure to laboratory light sources — Part 1: General guidance*

ISO 4892-2, *Plastics — Methods of exposure to laboratory light sources — Part 2: Xenon-arc sources*

ISO 6927, *Building construction — Jointing products — Sealants — Vocabulary*

ISO 13640, *Building construction — Jointing products — Specifications for test substrates*

CIE Publication No. 85:1989, *Technical Report — Solar spectral irradiance*

## 3 Terms and definitions

For the purposes of this International Standard, the terms and definitions given in ISO 6927 apply.

## 4 Principle

Specimens are prepared in which the sealant to be tested adheres to two parallel glass surfaces. After submitting the specimens to a cyclic exposure to artificial light at elevated temperature and to water, the specimens are extended to a defined width. After maintenance of the extension for a defined time, the specimens are examined for evidence of loss of adhesion or cohesion.

## 5 Apparatus

### 5.1 Glass supports, for the preparation of specimens.

For the definition of the glass, see ISO 13640. For each test specimen, two glass supports are required with a cross-section of dimensions as shown in Figure 1. Test substrates of other dimensions may be used, but the dimensions of the sealant bead and the area of adhesion shall be the same as those shown in Figure 1. The thickness of the glass shall be 6 mm.

### 5.2 Spacers, for the preparation of the specimens, of cross-section 12 mm × 12 mm, with anti-adherent surface (see Figure 1).

If the spacers are made of material to which the sealant adheres, their surface should be made anti-adherent, e.g. by a thin wax coating or a polyethylene film.

Dimensions in millimetres

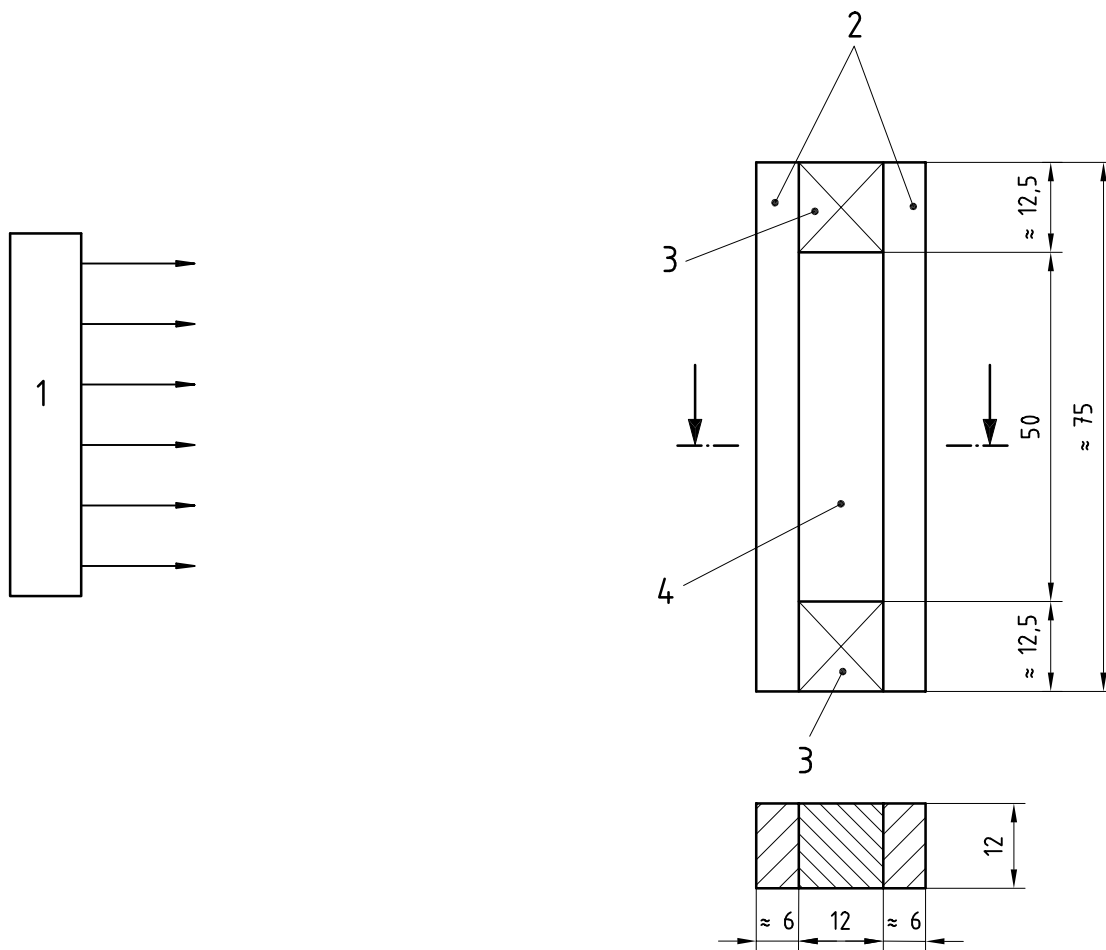

#### Key

- 1 Light
- 2 Glass supports
- 3 Spacers
- 4 Sealant

Figure 1 — Assembly for specimens and direction of light exposure

**5.3 Anti-adherent substrate**, for the preparation of test specimens, e.g. a polyethylene (PE) film, preferably on the advice of the sealant manufacturer.

**5.4 Ventilated convection-type oven**, capable of being maintained at  $(70 \pm 2) ^\circ\text{C}$  for conditioning according to method B.

**5.5 Container**, for immersing specimens in demineralized or distilled water, for conditioning according to method B.

**5.6 Test chamber with an artificial light source** (see 5.7), capable of exposure of the test specimens to radiation under dry conditions at a defined temperature, which is measured on a black standard thermometer.

The test chamber shall be sufficiently ventilated to maintain the test temperature in the dry phase. The radiation is directed to the surface of one of the glass substrates (see Figure 1).

If fully automated equipment is used, the exposure to water is accomplished in the same test chamber. This can be done either by immersion or by water spray. Demineralized water shall be used.

Suitable equipment and test procedures for cyclic exposures with intermittent water spray are described in ISO 4892-1.

If exposure to water is done outside the test chamber in a device where the test specimens are transferred manually, they shall be immersed in demineralized water at a defined temperature.

Contamination of the water for immersion or spray by-products leached out from the sealants shall be avoided. The recommended procedure is to test sealants of different chemical type separately and to use fresh water. If the water has to be recycled because of high consumption (e.g. in spraying), a sufficient exchange with clean water shall be maintained.

**5.7 Artificial light source with suitable filters**, for the simulation of the visible and ultraviolet part of daylight as defined in CIE Publication No. 85. The spectral distribution of radiation shall comply with the requirements outlined in ISO 4892-2 (method A). The irradiance at the surface of the test specimens between wavelengths 290 nm and 800 nm shall be  $(550 \pm 75) \text{ W/m}^2$ .

NOTE Light sources for the simulation of the global radiation at the surface of the earth are under development. The degree of approximation to the spectral distribution according to CIE Publication No. 85 depends on the type of lamp. Xenon-arc lamps and special metal halide lamps with suitable filters are regarded as adequate. Since the intensity and the spectral distribution change during service, the instructions of the suppliers as to how often the lamps have to be changed should be observed. Lamps with a spectral distribution which deviates from the natural light in parts of the spectrum, e.g. UV fluorescent lamps, may be used. The reference method, however, is based on lamps which represent the spectral distribution as defined in CIE Publication No. 85.

**5.8 Black standard thermometer**, which complies with the requirements outlined in 5.1.5 of ISO 4892-1:1999. Black-panel thermometers may also be used. Under given operating conditions they tend to indicate lower temperatures than the black standard thermometers. The temperature difference between the measurements will depend on the test temperature, but can be up to  $10 ^\circ\text{C}$ .

Readings shall only be taken after sufficient time has elapsed for the temperature to become steady. The temperature shall be controlled, e.g. by adjusting the air exchange rate.

**5.9 Extension machine**, with recording device, capable of extending the specimens at a rate of  $(5,5 \pm 0,7) \text{ mm/min}$ .

**5.10 Spacers**, with a width of 19,2 mm or 24,0 mm, to hold the specimens at an elongation of 60 % or 100 %, respectively.

**5.11 Measuring device**, scaled in 0,5 mm.

## 6 Preparation of specimens

The sealant and the glass shall be brought to  $(23 \pm 2)$  °C before preparation of the specimens. Three specimens shall be prepared.

For each specimen, two substrates (5.1) and two spacers (5.2) shall be assembled (see Figure 1) and set up on the anti-adherent substrate (5.3).

The instructions of the sealant manufacturer concerning, for instance, whether a primer is to be used, and the mixing procedure for multi-component sealants, shall be followed.

The hollow volume formed by the substrates and spacers shall be filled with the sealant. The following precautions shall be taken:

- a) the formation of air bubbles shall be avoided;
- b) the sealant shall be pressed to the contact surfaces of the substrates;
- c) the sealant surface shall be trimmed so that it is flush with the faces of the substrates and spacers.

The specimens shall be set on edge on one of the supports. The anti-adherent substrate shall be removed as soon as possible. The spacers shall remain in place for 28 days. The test specimens shall rest in this position to allow curing or optimum drying of the sealant.

## 7 Conditioning

### 7.1 General

The specimens shall be conditioned either in accordance with method A or method B, as agreed between the parties concerned.

### 7.2 Method A

The specimens shall be conditioned for 28 days at  $(23 \pm 2)$  °C and  $(50 \pm 5)$  % relative humidity.

### 7.3 Method B

The specimens shall be conditioned according to method A and then subjected three times to the following storage cycle:

- a) 3 days in the oven (5.4) at  $(70 \pm 2)$  °C;
- b) 1 day in a container (5.5) filled with demineralized or distilled water at a temperature of  $(23 \pm 2)$  °C;
- c) 2 days in the oven (5.4) at  $(70 \pm 2)$  °C;
- d) 1 day in a container (5.5) filled with demineralized or distilled water at a temperature of  $(23 \pm 2)$  °C.

Alternatively, this cycle may be performed in the order c) – d) then a) – b).

NOTE Method B is a commonly used conditioning procedure using the influence of heat and water. It is not suitable for giving information on the durability of the sealant.



## 8 Test procedures

### 8.1 General

After conditioning and removal of the spacers, the specimens shall be exposed to the artificial weathering cycle, either using the automatic or the manual procedure, as agreed by the parties concerned.

### 8.2 Exposure conditions

#### 8.2.1 General

The three test specimens shall be stored in the test chamber (5.6), and the cyclic weathering conditions as defined in 8.2.2 or 8.2.3 shall be applied.

#### 8.2.2 Automatic cycling

The standard conditions of test are 500 h of exposure, made up of 250 cycles. Each cycle is 120 min, consisting of the following:

- a dry period of 102 min, in which the specimens are exposed to the radiation and heat; from the start of the dry period the temperature is allowed to rise, until it reaches a steady temperature of  $(65 \pm 5)$  °C, as measured on the black standard thermometer (see 5.8);
- a wet period of 18 min, which is either water spraying or immersion in water; the initial water temperature shall be  $(25 \pm 3)$  °C and shall not be allowed to rise above 33 °C during the testing. During the wet period the light may be switched off.

#### 8.2.3 Manual cycling

The specimens shall be transferred manually between the dry phase chamber and the wet phase chamber. For this type of cyclic exposure, immersion in water is used. To ensure that the same surface of the specimens is always exposed to the radiation, one surface shall be marked.

The standard conditions of test are 504 h of exposure, made up of three cycles. Each cycle is 168 h consisting of:

- a period of 5 days, each day consisting of 5 h of immersion in water at  $(25 \pm 3)$  °C and 19 h of exposure to radiation at  $(65 \pm 5)$  °C as measured on the black standard thermometer;
- a period of 48 h with exposure to radiation at  $(65 \pm 5)$  °C as measured on the black standard thermometer.

### 8.3 Elongation of the specimens

After exposure to the artificial weathering cycle, the specimens shall be stored for 24 h at  $(23 \pm 2)$  °C and  $(50 \pm 5)$  % relative humidity.

Subsequently, the specimens shall be placed on the extension machine (5.9) and elongated for 60 % or 100 %, or any other percentage of their initial width as agreed by the parties concerned, at a rate of  $(5,5 \pm 0,7)$  mm/min. The elongation shall be maintained for 24 h using the appropriate spacers (5.10).

Table 1 gives the joint widths,  $l_1$ , in millimetres, after elongation of the test specimens having an initial width of 12 mm.

After testing, the test specimens shall be examined for evidence of loss of adhesion and/or cohesion. The depth of any loss of adhesion or cohesion shall be measured, using a suitable measuring device (5.11) capable of reading to 0,5 mm.

Table 1 — Joint widths after extension

Elongation %	Final joint width, $l_1$ mm
60	19,2
100	24,0

## 9 Test report

The test report shall include the following information:

- a) name of test laboratory and test date;
- b) reference to this International Standard;
- c) name, type (chemical family) and colour of the sealant;
- d) batch of sealant from which test specimens were produced;
- e) the primer used, if applicable;
- f) method of conditioning used (see clause 7);
- g) test procedure used (kind of exposure cycle, type of lamp, intensity of light, and whether water spray or immersion in water was applied, see 8.2); if the light was left on in the wet period (8.2.2), this should be stated;
- h) elongation used (see 8.3);
- i) details of any loss of adhesion and/or cohesion;
- j) any deviations from the specified test conditions.



---

---

**ICS 91.100.50**

Price based on 6 pages