**Containers and accessories for
pharmaceutical preparations —**

**Part 2:
Screw-neck glass bottles for syrups**

*Réipients et accessoires pour préparations pharmaceutiques —
Partie 2: Flacons en verre à bouchon à vis pour sirops*



COPYRIGHT PROTECTED DOCUMENT

© ISO 2016, Published in Switzerland

All rights reserved. Unless otherwise specified, no part of this publication may be reproduced or utilized otherwise in any form or by any means, electronic or mechanical, including photocopying, or posting on the internet or an intranet, without prior written permission. Permission can be requested from either ISO at the address below or ISO's member body in the country of the requester.

ISO copyright office
Ch. de Blandonnet 8 • CP 401
CH-1214 Vernier, Geneva, Switzerland
Tel. +41 22 749 01 11
Fax +41 22 749 09 47
copyright@iso.org
www.iso.org

Contents

	Page
Foreword	iv
1 Scope	1
2 Normative references	1
3 Terms and definitions	1
4 Dimensions and designation	2
4.1 Dimensions	2
4.2 Designation	2
5 Requirements	2
5.1 Material	2
5.2 Performance	2
5.2.1 Vertical load resistance	2
5.2.2 Hydrolytic resistance	2
5.2.3 Thermal shock resistance	2
6 Marking	2
Annex A (normative) Neck finishes	5

Foreword

ISO (the International Organization for Standardization) is a worldwide federation of national standards bodies (ISO member bodies). The work of preparing International Standards is normally carried out through ISO technical committees. Each member body interested in a subject for which a technical committee has been established has the right to be represented on that committee. International organizations, governmental and non-governmental, in liaison with ISO, also take part in the work. ISO collaborates closely with the International Electrotechnical Commission (IEC) on all matters of electrotechnical standardization.

The procedures used to develop this document and those intended for its further maintenance are described in the ISO/IEC Directives, Part 1. In particular the different approval criteria needed for the different types of ISO documents should be noted. This document was drafted in accordance with the editorial rules of the ISO/IEC Directives, Part 2 (see www.iso.org/directives).

Attention is drawn to the possibility that some of the elements of this document may be the subject of patent rights. ISO shall not be held responsible for identifying any or all such patent rights. Details of any patent rights identified during the development of the document will be in the Introduction and/or on the ISO list of patent declarations received (see www.iso.org/patents).

Any trade name used in this document is information given for the convenience of users and does not constitute an endorsement.

For an explanation on the meaning of ISO specific terms and expressions related to conformity assessment, as well as information about ISO's adherence to the World Trade Organization (WTO) principles in the Technical Barriers to Trade (TBT) see the following URL: www.iso.org/iso/foreword.html.

The committee responsible for this document is ISO/TC 76, *Transfusion, infusion and injection, and blood processing equipment for medical and pharmaceutical use*.

This third edition cancels and replaces the second edition (ISO 11418-2:2005), which has been technically revised by

- updating [Figure 1](#) on typical screw-neck glass bottle and [Table 1](#) on nominal volume, brimful capacity and dimensions of screw-neck glass bottles,
- adding the size 105 ml in [Table 1](#),
- including a normative annex on neck finishes, and
- editorially revising this document.

A list of all the parts of ISO 11418 can be found on the ISO website.

Containers and accessories for pharmaceutical preparations —

Part 2: Screw-neck glass bottles for syrups

1 Scope

This document specifies the design, dimensions, material and requirements of screw-neck glass bottles for pharmaceutical preparations in liquid form (syrups). Screw-neck glass bottles are applicable to primary packs used in direct contact with a drug.

This document is applicable to screw-neck glass bottles used in pharmacy. Together with the corresponding closure systems, they serve for packaging of pharmaceutical preparations which are not intended for parenteral use.

NOTE The potency, purity, stability and safety of a drug during its manufacture and storage can be strongly affected by the nature and performance of the primary pack.

2 Normative references

The following documents are referred to in the text in such a way that some or all of their content constitutes requirements of this document. For dated references, only the edition cited applies. For undated references, the latest edition of the referenced document (including any amendments) applies.

ISO 719, *Glass — Hydrolytic resistance of glass grains at 98 degrees C — Method of test and classification*

ISO 720, *Glass — Hydrolytic resistance of glass grains at 121 degrees C — Method of test and classification*

ISO 1101, *Geometrical product specifications (GPS) — Geometrical tolerancing — Tolerances of form, orientation, location and run-out*

ISO 4802-1, *Glassware — Hydrolytic resistance of the interior surfaces of glass containers — Part 1: Determination by titration method and classification*

ISO 4802-2, *Glassware — Hydrolytic resistance of the interior surfaces of glass containers — Part 2: Determination by flame spectrometry and classification*

ISO 7459, *Glass containers — Thermal shock resistance and thermal shock endurance — Test methods*

ISO 8113, *Glass containers — Resistance to vertical load — Test method*

3 Terms and definitions

No terms and definitions are listed in this document.

ISO and IEC maintain terminological databases for use in standardization at the following addresses:

— IEC Electropedia: available at <http://www.electropedia.org/>

— ISO Online browsing platform: available at <http://www.iso.org/obp>

4 Dimensions and designation

4.1 Dimensions

The dimensions of screw-neck glass bottles for pharmaceutical preparations in liquid form shall be as shown in [Figure 1](#) and as given in [Table 1](#).

The neck finish of screw-neck glass bottles shall comply with [Annex A, Figure A.1](#) or [Figure A.2](#), as appropriate.

Tolerancing of form, orientation, location and run-out not specified in this document shall be in accordance with ISO 1101.

4.2 Designation

Screw-neck glass bottles for pharmaceutical use shall be designated by a reference to this document, followed by the nominal volume, the colour of the glass and bore size.

EXAMPLE A screw-neck glass bottle of nominal volume 500 ml, made of colourless glass (cl) of hydrolytic resistance container class ISO 4802-HC 3, in accordance with this document is designated as follows:

Screw-neck glass bottle ISO 11418-2 – 500 – cl

5 Requirements

5.1 Material

The material shall be colourless (cl) or amber (br) borosilicate glass (see ISO 4802-1 or ISO 4802-2) or soda-lime-silica glass (see ISO 4802-1 or ISO 4802-2) of hydrolytic resistance grain class ISO 719-HGB 3 or ISO 720-HGA 2.

5.2 Performance

5.2.1 Vertical load resistance

The resistance to vertical load shall be in accordance with ISO 8113.

5.2.2 Hydrolytic resistance

When tested in accordance with ISO 4802-1 and ISO 4802-2, the hydrolytic resistance of the internal surface of the screw-neck glass bottle shall comply with the requirements of the hydrolytic resistance container class ISO 4802-HC 3.

5.2.3 Thermal shock resistance

Screw-neck glass bottles shall withstand the thermal shock of a temperature difference of 42 °C when tested in accordance with the thermal shock resistance test specified in ISO 7459.

6 Marking

The screw-neck glass bottle shall be marked with the information specified in [Figure 1](#).

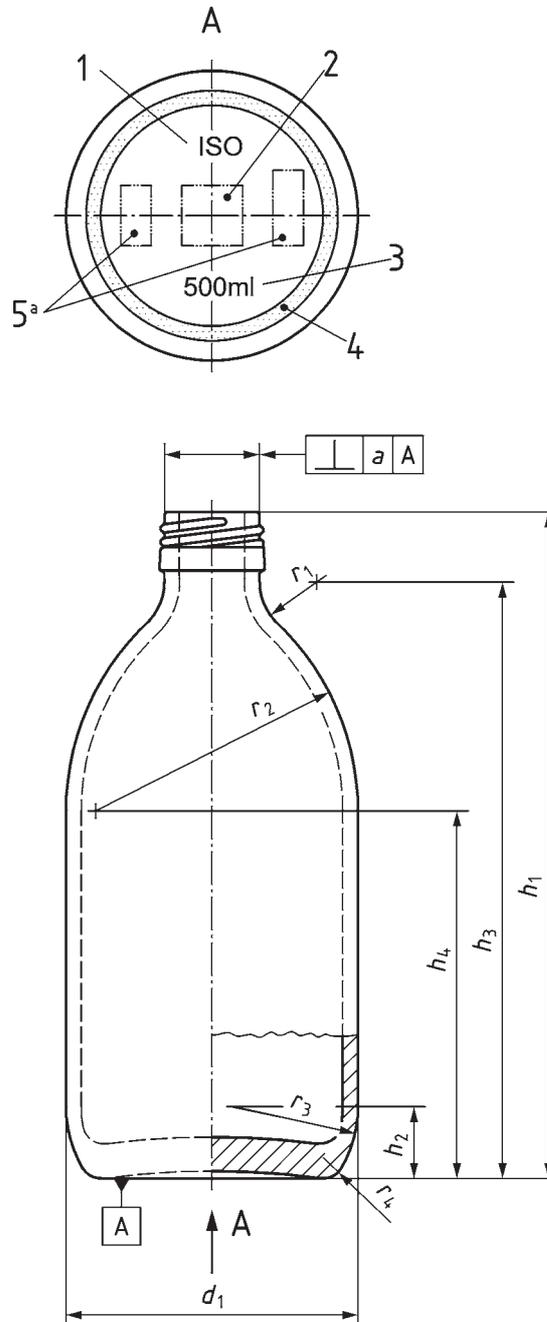

Key

- 1 ISO letters (optional)
- 2 manufacturer's trademark
- 3 nominal volume (optional)
- 4 bottom surface may be granular, flat or riffled
- 5 manufacturer's code/designation of the mould
- a The number of the mould may be placed on the curve r_3 , on the bottom or on the shoulder of the bottle.

Figure 1 — Typical screw-neck glass bottle, showing marking locations

Table 1 — Nominal volume, brimful capacity and dimensions of screw-neck glass bottles for syrups

Dimensions in millimetres

Nominal volume ml	Minimum brimful capacity ml	d_1		h_1		h_2	h_3	h_4	r_1	r_2	r_3	r_4	Mass g
		nom.	tol.	nom.	tol.								
		≈	≈	≈	≈	≈	≈	≈					
30	35,7	35,0	±0,7	67,0	±0,8	8,8	48,8	30,4	6,5	29,0	18,0	2,5	39
50	55,3	38,6	±0,7	85,4	±0,8	10,0	67,0	43,6	5,5	38,0	19,0	3,0	55
60	65,7	38,6	±0,7	94	±0,8	10,0	75,7	57,0	5,5	38,0	19,0	3,0	60
75	81,0	43,9	±0,7	95	±0,8	11,3	79,6	49,3	6,0	39,0	19,6	3,0	67
90	95,2	43,9	±0,7	103,1	±0,8	11,3	84,9	59,8	5,9	32,0	19,6	3,0	69
100	105,5	46,1	±0,8	104,8	±0,9	11,7	86,4	58,3	6,5	36,0	19,9	3,5	72
105	112,5	46,1	±0,8	109	±0,8	10,7	90,6	60,8	6,5	34,0	18,0	3,0	70
125	130,0	49,0	±0,8	114,4	±0,9	12,5	96,0	62,9	7,5	44,0	21,5	3,5	83
150	154,5	51,6	±0,8	122,8	±0,9	13,0	104,4	68,9	8,0	46,0	23,0	3,5	98
180	185,2	54,7	±0,9	129,9	±1,0	14,0	111,5	72,7	9,0	49,0	24,0	4,0	110
200	204,9	57,0	±0,9	133,3	±1,0	14,5	114,4	73,0	10,5	51,0	25,0	4,0	120
250	255,2	61,7	±1,0	142,9	±1,0	15,5	124,0	78,0	12,0	55,0	26,5	4,5	145
300	309,2	65,6	±1,0	151,3	±1,0	16,5	132,4	82,3	13,0	59,0	28,0	5,0	170
500	512,3	76,8	±1,2	176,8	±1,1	19,0	157,9	97,3	15,0	69,0	32,5	5,5	240
1 000	1 010	97,5	±1,5	215,6	±1,3	24,0	196,7	119,2	17,0	84,0	41,0	7,0	450

Annex A (normative)

Neck finishes

Neck finishes of screw-neck glass bottles for syrups shall comply with [Figure A.1](#) (19,4 mm bore) or [Figure A.2](#) (20,0 mm bore), as appropriate.

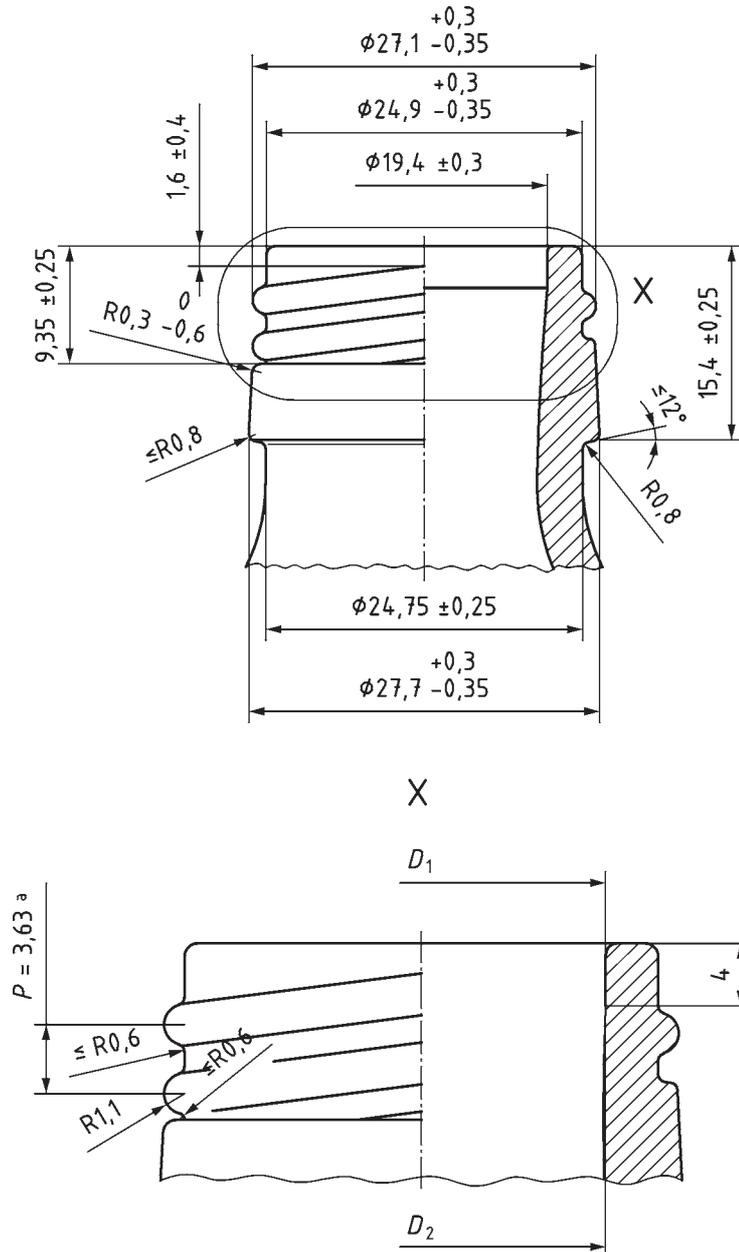

NOTE Diameter d_2 at 4 mm depth and $\geq \phi 17$ mm.

Figure A.1 — 19,4 mm bore - 28 mm Bottle Neck Finish

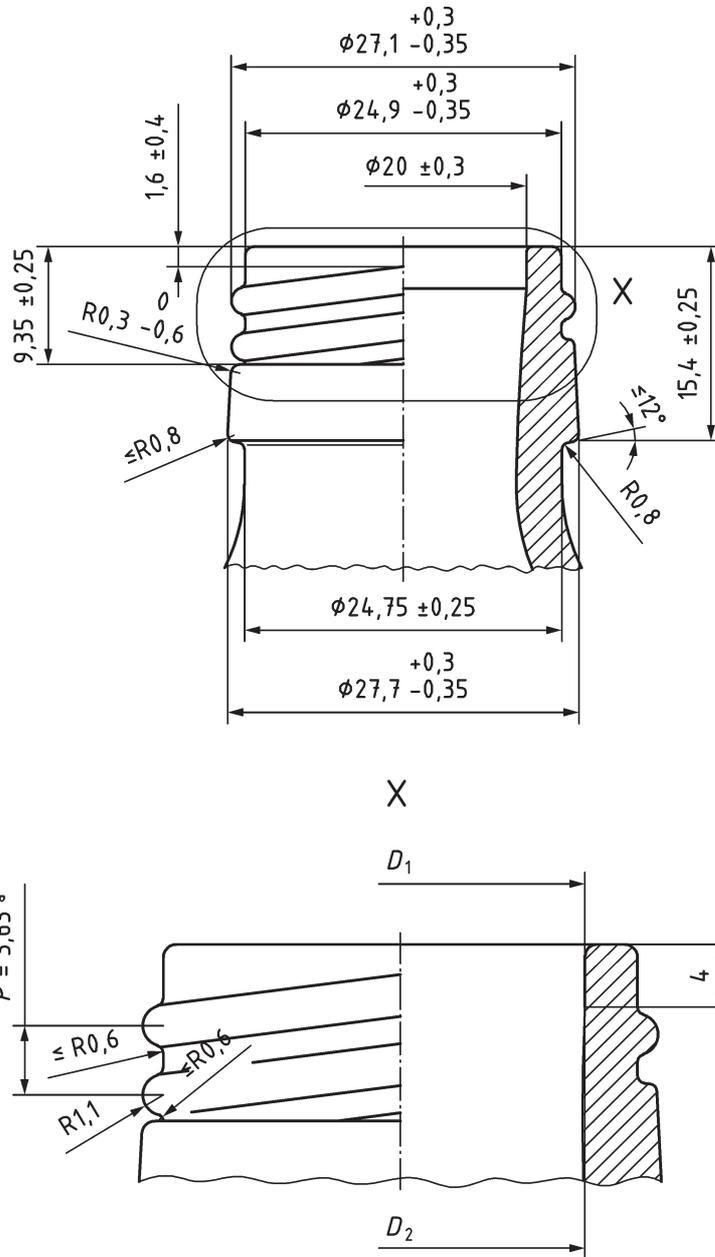

NOTE Diameter d_2 at 4 mm depth and $\geq \phi 17$ mm.

Figure A.2 — 20 mm bore - 28 mm Bottle Neck Finish

