

INTERNATIONAL
STANDARD

ISO
11416

First edition
1995-06-01

**Tennis rackets — Racket components and
physical parameters**

*Raquettes de tennis — Composants d'une raquette et paramètres
physiques*



Reference number
ISO 11416:1995(E)

Foreword

ISO (the International Organization for Standardization) is a worldwide federation of national standards bodies (ISO member bodies). The work of preparing International Standards is normally carried out through ISO technical committees. Each member body interested in a subject for which a technical committee has been established has the right to be represented on that committee. International organizations, governmental and non-governmental, in liaison with ISO, also take part in the work. ISO collaborates closely with the International Electrotechnical Commission (IEC) on all matters of electrotechnical standardization.

Draft International Standards adopted by the technical committees are circulated to the member bodies for voting. Publication as an International Standard requires approval by at least 75 % of the member bodies casting a vote.

International Standard ISO 11416 was prepared by Technical Committee ISO/TC 83, *Sports and recreational equipment*, Subcommittee SC 6, *Rackets*.

Annexes A and B of this International Standard are for information only.

© ISO 1995

All rights reserved. Unless otherwise specified, no part of this publication may be reproduced or utilized in any form or by any means, electronic or mechanical, including photocopying and microfilm, without permission in writing from the publisher.

International Organization for Standardization
Case postale 56 • CH-1211 Genève 20 • Switzerland

Printed in Switzerland

Tennis rackets — Racket components and physical parameters

1 Scope

This International Standard specifies components and physical parameters of tennis rackets and it defines the terminology used.

It also specifies laboratory methods for measuring some specific parameters of tennis rackets and gives guidelines for the indication of these parameters.

The specification of laboratory methods will permit the comparability of published measurements.

This International Standard does not include the influence of these parameters on the quality of the tennis racket.

NOTE 1 For specific requirements of tennis rackets, refer to the "Rules of the International Tennis Federation (ITF)".

2 Normative reference

The following standard contains provisions which, through reference in this text, constitute provisions of this International Standard. At the time of publication, the edition indicated was valid. All standards are subject to revision, and parties to agreements based on this International Standard are encouraged to investigate the possibility of applying the most recent editions of the standards indicated below. Members of IEC and ISO maintain registers of currently valid International Standards.

ISO 554:1976, *Standard atmospheres for conditioning and/or testing — Specifications*.

3 Definitions

The definitions of terms used shall provide a basis for communication between manufacturers and retailers. These clarifications of terms will allow the consumers a better access to the product.

For the purposes of this International Standard, the following definitions apply.

3.1 Racket components

3.1.1 tennis racket (hereafter referred to as "racket"): Playing implement consisting of frame and strings and used with the intended purpose of striking a tennis ball and playing the game of tennis.

3.1.2 racket frame (hereafter referred to as "frame"): Racket without strings.

3.1.3 raw frame: Drilled frame without all detachable parts.

3.1.4 strings: Part of the racket which comes into contact with the tennis ball.

3.1.5 grip: Part of the racket where the player holds the racket.

3.1.6 grip size, *s*: Circumference of the grip.

3.1.7 shaft: Region of the frame between grip and heart.

3.1.8 heart: Region of the frame between shoulder and shaft.

NOTE 2 The design of the heart can differ.

3.1.9 shoulder: Region of the frame between head and heart.

3.1.10 head: Furthestmost (distal) region from the grip which merges with the shoulder in points A and A'.

See figure 1.

3.1.11 string protection; head protection: Components situated on the outer side of the frame which should prevent frame and/or string from damage when in use.

3.1.12 string area: Area which is limited by the inner boundaries of head, shoulder and heart.

NOTE 3 For the tournament rules of the ITF, the dimensions of this area are limited to

- a maximum inner length of the string area of 393,7 mm (15 1/2 in);
- a maximum inner width of the string area of 292,1 mm (11 1/2 in).

3.2 Physical parameters

3.2.1 racket or frame length, L : Maximum overall length of the racket or frame.

See figure 2.

NOTE 4 According to the rules of the ITF, the maximum length shall be 812,8 mm (32 in).

3.2.2 racket or frame mass: Mass of the racket or frame.

3.2.3 balance point, B : The location of the centre of mass along the longitudinal axis of the racket or frame; the racket or frame balances when supported at this point.

See figure 2.

3.2.4 balance length, l_B : Distance of the balance point B from the grip end.

See figure 2.

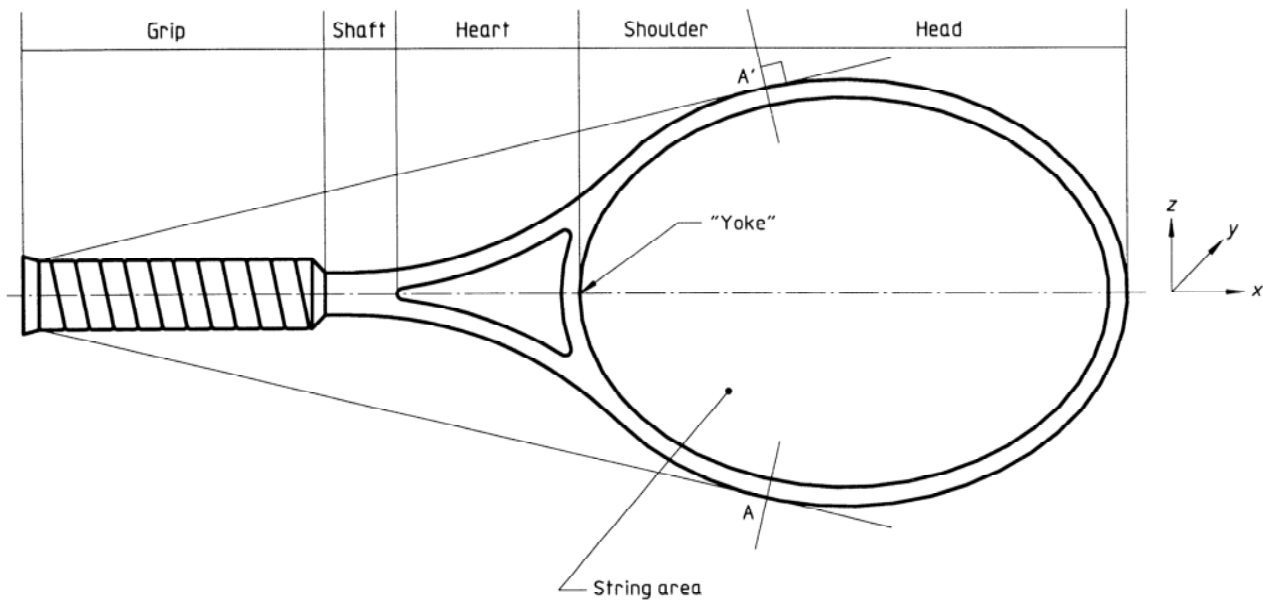

Figure 1 — Diagram illustrating the components of a tennis racket

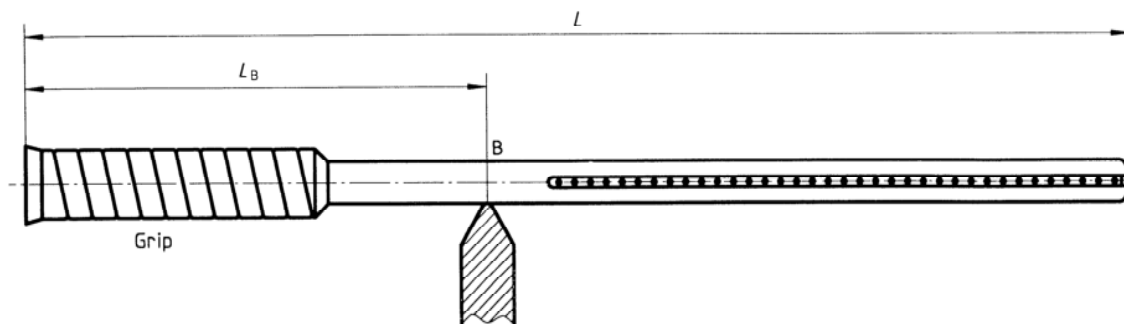

Figure 2 — Balance point (B) of a tennis racket

3.2.5 Moments of inertia

3.2.5.1 moments of inertia with respect to z -axis or y -axis, I_z , I_y : Moments of inertia of the racket or frame, in kilograms centimetre squared, resulting from rotations about the z -axis and y -axis respectively, with the point of rotation located 100 mm from the grip end.

See figure 1.

3.2.5.2 moment of inertia with respect to x -axis, I_x : Moment of inertia of the racket or frame, in kilograms centimetre squared, resulting from rotations about the x -axis.

See figure 1.

4 Laboratory measurement methods

4.1 General

4.1.1 Test sample

All measurements shall be made on a finished racket or frame.

4.1.2 Conditioning of the test sample and test equipment

The sample and all test equipment shall be conditioned for at least 2 h at a temperature of $23\text{ °C} \pm 2\text{ °C}$, prior to the measurements.

4.2 Grip size

4.2.1 Test devices

Flexible steel tape, with a width of 6 mm and a maximum thickness of 0,2 mm, and device for measuring length with an accuracy of $\pm 0,5$ mm.

4.2.2 Procedure

The flexible steel tape shall be wound around the grip, between 50 mm and 60 mm from the grip end.

The tape shall be marked with points to measure the circumference of the grip. After unwinding the tape, the distance between the marking points shall be measured.

Alternatively, the tape may be graduated in millimetres and the circumference measured directly.

4.3 String area

4.3.1 Test device

Millimetre-squared paper.

4.3.2 Procedure

The size of the string area shall be transferred to the millimetre-squared paper.

The area indicated in this way on the paper shall be determined by counting squares.

NOTE 5 Alternative methods may be used if an accuracy of $\pm 100\text{ mm}^2$ is ensured.

4.4 Length of the racket or frame

4.4.1 Test device

Device for measuring length with an accuracy of ± 1 mm.

4.4.2 Procedure

The length shall be determined by using a device according to 4.4.1.

4.5 Mass of the racket or frame

4.5.1 Test device

Scale with an accuracy of ± 1 g.

4.5.2 Procedure

The mass shall be determined by using a scale according to 4.5.1

4.6 Balance point, B (see figure 2)

4.6.1 Test device

Prism according to figure 3, and device for measuring length with an accuracy of ± 1 mm.

4.6.2 Procedure

The location of the balance point shall be determined on a racket or frame.

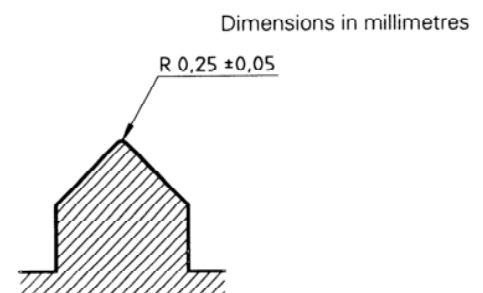

Figure 3 — Prism used in the test device for measuring balance point

4.7 Moments of inertia

4.7.1 Test device

The test device shall have an accuracy of better than 2 %.

4.7.2 Moments of inertia with respect to y-axis and z-axis

An example is shown in A.1.

4.7.3 Moment of inertia with respect to x-axis

An example is shown in A.2.

5 Test report

The test report shall include at least the following information:

- a) reference to this International Standard;
- b) name of manufacturer/importer;
- c) brand name;
- d) model, type, year of issue;
- e) values of measured parameters on the racket or frame;
- f) any deviation from the specifications of this International Standard;
- g) name and signature of the person responsible for the test, and date.

6 Indication of technical data

6.1 General

If technical data are indicated, it shall be clear whether they refer to the racket or the frame. Technical data marked on the product shall be clearly visible.

The expression of technical data in specifications, test reports or on the product shall comply with the following specifications.

6.2 Grip size

The grip size shall be indicated in millimetres or by designation according to table 1.

The indicated values shall not deviate from the measured values by more than 1 %.

Table 1

Designation	Grip size, <i>s</i> mm
000	$94 < s \leq 97$
00	$97 < s \leq 100$
0	$100 < s \leq 103$
1	$103 < s \leq 106$
2	$106 < s \leq 110$
3	$110 < s \leq 113$
4	$113 < s \leq 116$
5	$116 < s \leq 119$
6	$119 < s \leq 122$
7	$122 < s \leq 125$

NOTE 6 To convert the grip size to inches, see annex B.

6.3 String area

The string area may be indicated in square centimetres, or as the percentage *x* by which it exceeds a reference string area of 440 cm², or by the designation according to table 2.

The indicated value shall not deviate from the measured value by more than 1 %.

Table 2

Designation	Percentage, <i>x</i> %	Area, <i>A</i> cm ²
Standard	0 to 17	$440 < A \leq 517$
Mid size	18 to 32	$517 < A \leq 583$
Super mid size	33 to 47	$583 < A \leq 647$
Oversize	greater than 47	$647 < A$

NOTE 7 To convert to square inches, divide the value in square centimetres by 6,45.

6.4 Length

The length shall be indicated in millimetres.

The indicated value shall not deviate from the measured value by more than 1 mm.

NOTE 8 To convert to inches, divide the value in millimetres by 25,4.

6.5 Mass

The mass shall be indicated in grams.

The indicated value shall not deviate from the measured value by more than 1 %.

If the mass is indicated by a range of values, the measured value shall lie within that range.

The maximum range shall be ± 3 % of the mean value of the two extremes.

NOTE 9 To convert to ounces, divide by 28,35.

6.6 Balance length, L_B

The balance length (L_B) shall be indicated in millimetres.

The indicated value shall not deviate from the measured value by more than 1 mm.

If the balance length is indicated by a range of values, the measured value shall lie within that range.

The maximum range shall be ± 3 % of the mean value of the two extremes.

See note 7.

6.7 Moments of inertia

The moments of inertia (I_x , I_y and I_z) shall be indicated in kilograms centimetre squared.

The indicated values shall not deviate from the measured values by more than 2 %.

If the moment of inertia is indicated by a range of values, the measured values shall lie within that range.

The maximum range shall be ± 4 % of the mean value of the two extremes.

Annex A (informative)

Schematic examples for test methods for measuring the moments of inertia

A.1 Moments of inertia (I_y and I_z) with respect to y -axis and z -axis

The moments of inertia with respect to the y -axis and z -axis may be determined by allowing the racket or frame to pivot about a point 100 mm from the end of the grip.

See figures A.1 and A.2.

In both cases, the time, in seconds, for 10 complete swings is measured to an accuracy of 0,1 s, from which the period for 1 swing (T) is calculated.

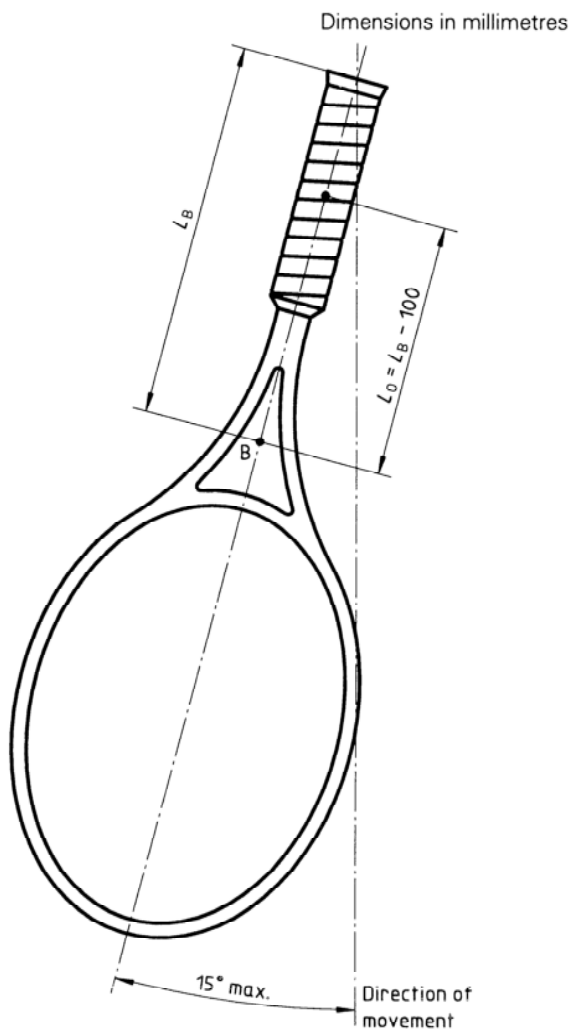

Figure A.1 — Moment of inertia with respect to the y -axis

Calculate the moment of inertia (I_y or I_z), using the formula

$$\frac{T^2}{4\pi^2} \times m L_0 g$$

where

m is the mass of the racket or frame;

L_0 is the distance, in millimetres, from the centre of gravity of racket or frame to the pivot point ($L_0 = L_B - 100$);

g is the acceleration due to gravity.

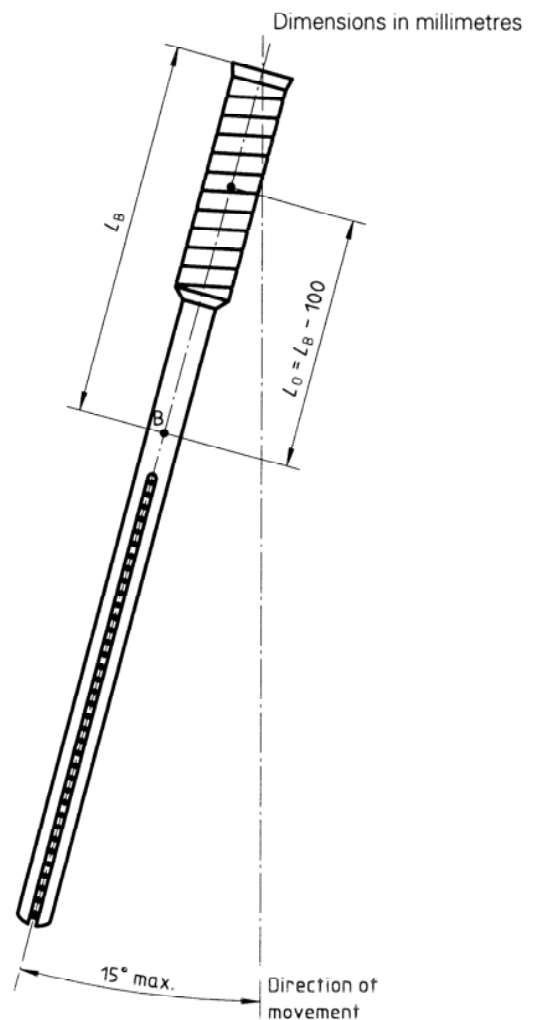

Figure A.2 — Moment of inertia with respect to the z -axis

A.2 Moment of inertia (I_x) with respect to x -axis

The moment of inertia with respect to the x -axis may be determined by suspending the racket or frame from the handle end by a carrier and a length of single strand steel wire. The top end of the wire is fixed to a large stationary mass. The racket is allowed to oscillate $\pm 180^\circ$ about the x -axis and the time, in seconds, for 10 complete oscillations is measured to an accuracy of 0,1 s, from which the period of one oscillation (T_2) is calculated.

The racket or frame is replaced by a uniform disc whose mass and moment of inertia are similar to those of the racket or frame and the test is repeated, giving a period of oscillation (T_1). The carrier alone is then allowed to oscillate and its period (T_0) is measured.

Then

$$I_x = I_1 \times \frac{T_2^2 - T_0^2}{T_1^2 - T_0^2}$$

where I_1 is the moment of inertia of the disc.

$$I_1 = \frac{mr^2}{2}$$

where

m is the mass of the disc;

r is the radius of the disc.

NOTE 9 The moment of inertia of the carrier should be less than 200 g·cm². The steel wire should be between 0,8 m and 1,2 m in length and between 0,8 mm and 1,2 mm in diameter. The mass of the disc should be between 250 g and 400 g and its moment of inertia should be between 10 kg·cm² and 15 kg·cm² (e.g. aluminium, diameter 176 mm, thickness 5 mm).

Annex B
(informative)

Conversion of grip size to inches

Grip size, s mm	Corresponding grip size in
$94 < s \leq 97$	3 3/4
$97 < s \leq 100$	3 7/8
$100 < s \leq 103$	4
$103 < s \leq 106$	4 1/8
$106 < s \leq 110$	4 1/4
$110 < s \leq 113$	4 3/8
$113 < s \leq 116$	4 1/2
$116 < s \leq 119$	4 5/8
$119 < s \leq 122$	4 3/4
$122 < s \leq 125$	4 7/8

This page intentionally left blank

ICS 97.220.40

Descriptors: sports equipment, tennis, tennis rackets, components, tests, laboratory tests, determination, physical properties, designation, marking.

Price based on 8 pages
