**Building construction machinery and
equipment — Terms and definitions**

*Machines et matériels pour la construction des bâtiments — Termes et
définitions*



Foreword

ISO (the International Organization for Standardization) is a worldwide federation of national standards bodies (ISO member bodies). The work of preparing International Standards is normally carried out through ISO technical committees. Each member body interested in a subject for which a technical committee has been established has the right to be represented on that committee. International organizations, governmental and non-governmental, in liaison with ISO, also take part in the work. ISO collaborates closely with the International Electrotechnical Commission (IEC) on all matters of electrotechnical standardization.

Draft International Standards adopted by the technical committees are circulated to the member bodies for voting. Publication as an International Standard requires approval by at least 75 % of the member bodies casting a vote.

International Standard ISO 11375 was prepared by Technical Committee ISO/TC 195, *Building construction machinery and equipment*.

© ISO 1998

All rights reserved. Unless otherwise specified, no part of this publication may be reproduced or utilized in any form or by any means, electronic or mechanical, including photocopying and microfilm, without permission in writing from the publisher.

International Organization for Standardization
Case postale 56 • CH-1211 Genève 20 • Switzerland
Internet central@iso.ch
X.400 c=ch; a=400net; p=iso; o=isocs; s=central

Printed in Switzerland

Building construction machinery and equipment — Terms and definitions

Scope

This International Standard specifies terminology for machines and equipment used in the building construction industry, for ease for reference and for use in discussions on standardization activities.

This International Standard refers to machines and equipment used on construction sites. They are divided into five groups:

- assembly of machines and components for installation and extraction of piles;
- equipment for preparing, conveying and compaction of concrete, mortar and processing reinforcement and formwork;
- machinery and equipment for aggregate processing;
- equipment for finishing work and maintenance;
- machinery and equipment for general use in construction processes.

The machinery and equipment presented in these particular groups are used primarily in building processes.

This International Standard does not include groups of building machines such as earth-moving machinery, cranes, lifting and access machinery.

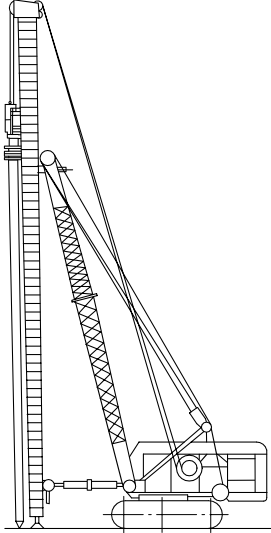
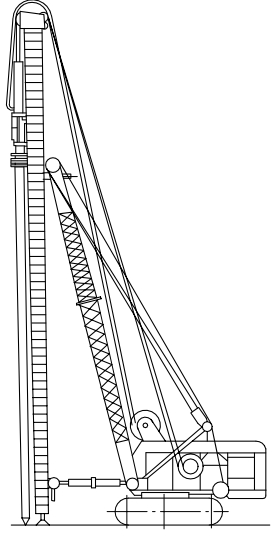
Item	Term	Definition	Illustration
1 Foundation equipment			
1.1	Piling equipment	Assembly of machines and components for the installation and extraction of piles.	See figures 1 to 8.
1.1.1	Piling rig	Carrier machine complete with leader attachment and leader for support of pile installation equipment.	
1.1.2	Impact hammer	Hammer whose striking energy is produced by raising the striking mass; at the end of the subsequent downward motion this mass impacts directly or indirectly on the pile.	See figures 1 to 4.
1.1.2.1	Drop hammer	Hammer whose striking mass is raised by a wire rope roll on a winch or by similar means.	 <p style="text-align: center;">Figure 1</p>
1.1.2.2	Steam / Air hammer	Hammer whose striking mass is raised by air or steam pressure.	 <p style="text-align: center;">Figure 2</p>

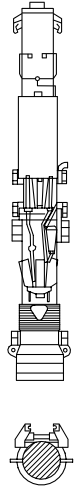
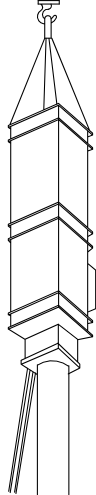
Item	Term	Definition	Illustration
1.1.2.3	Diesel hammer	<p>Hammer whose striking mass is raised by pressure of gases resulting from the combustion of a fuel mixture.</p> <p>NOTE — Normally this is diesel fuel, but other compression ignition engine fuels can also be used.</p>	 <p style="text-align: center;">Figure 3</p>
1.1.2.4	Hydraulic hammer	<p>Hammer whose striking mass is raised by hydraulic pressure.</p>	 <p style="text-align: center;">Figure 4</p>
1.1.3	Vibration equipment	<p>Equipment generating unidirectional vibrations, in most instances vertical; these vibrations may be used to install or extract piles.</p> <p>NOTE — Vibration is produced in a vibrator gearbox while a suspension device, placed above the vibrator gearbox, dampens in order to protect the supporting crane. The element to be installed in or extracted from the ground is rigidly held under the vibrator gearbox by means of one or more clamps.</p>	See figures 5 and 6.

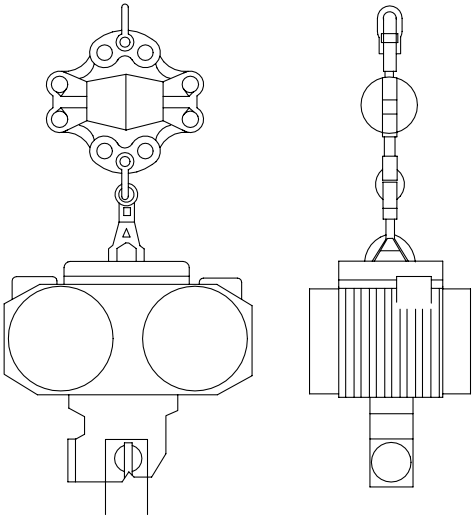
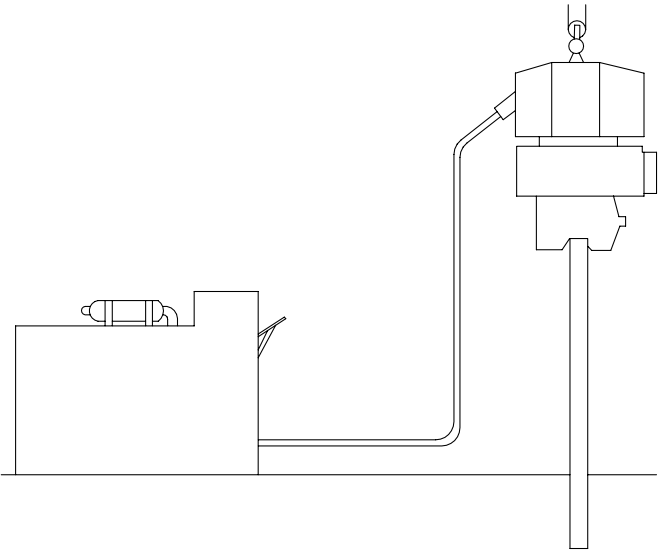
Item	Term	Definition	Illustration
1.1.3.1	Vibrating pile driver (electric type)	Pile driver with electric motor(s) used to generate the vibrations.	 <p style="text-align: center;">Figure 5</p>
1.1.3.2	Vibrating pile driver (hydraulic type)	Pile driver with hydraulic motor(s) used to generate the vibrations.	 <p style="text-align: center;">Figure 6</p>
1.1.4	Pile forcing equipment	Equipment for driving jointed or unjointed piles, as well as steel diaphragms or sections into the ground.	See figures 7 and 8.

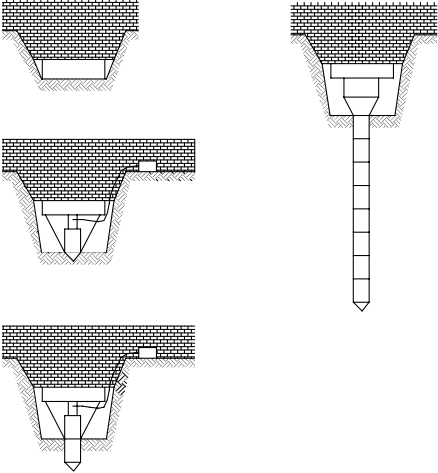
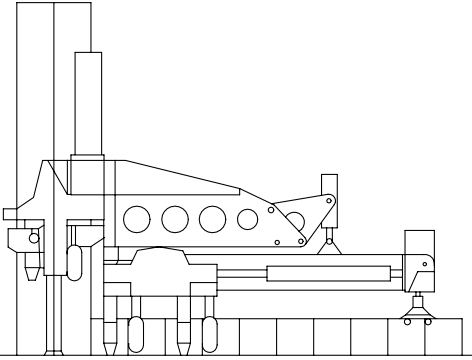
Item	Term	Definition	Illustration
<p>1.1.4.1</p>	<p>Equipment for jacking preformed pile sections into the ground</p>	<p>Equipment comprising a hydraulic power unit and a hydraulic cylinder, used for jacking pre-fabricated pile sections in an excavation under and against existing foundations.</p> <p>NOTE — Such equipment is used in underpinning old foundations in cases where there is insufficient room for other machines.</p>	 <p style="text-align: center;">Figure 7</p>
<p>1.1.4.2</p>	<p>Static pile pushing/pulling devices</p>	<p>Devices designed for driving or extracting sheet piles by applying a steady force to the piles by means of several vertical hydraulic jacks which are clamped on a number of sheet piles that have been previously installed in the ground.</p>	 <p style="text-align: center;">Figure 8</p>
<p>1.2</p>	<p>Diaphragm walling equipment</p>	<p>Machines for installation of diaphragm walls, cast-in-place piles of non-circular section piles, and cut-off walls.</p>	<p>See figures 9 and 10.</p>

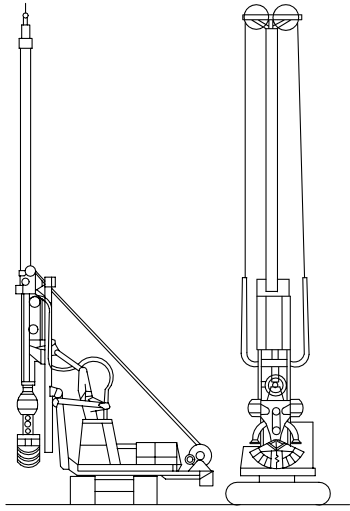
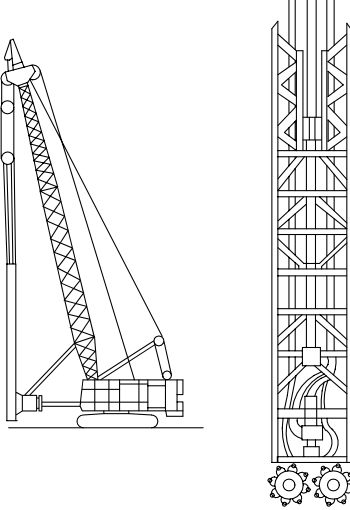
Item	Term	Definition	Illustration
1.2.1	Diaphragm walling equipment using hydraulic grabs and telescopic extension rods	<p>Truck- or crawler-mounted rig, comprising a hydraulically operated grab bucket and a telescopic extension rod.</p> <p>NOTE — Used for making deep, non-circular holes or trenches in the ground, in which concrete piles and sheet piles are formed. Also cut-off walls may be formed in such trenches.</p>	 <p style="text-align: center;">Figure 9</p>
1.2.2	Diaphragm walling equipment using rope-operated grabs	<p>Truck- or crawler-mounted rig comprising a rope-operated grab bucket mounted directly on a derrick or on a telescopic extension rod.</p> <p>NOTE — Used for making non-circular holes and trenches in the ground, in which concrete piles and sheet piles or cut-off walls are formed. A stabilizing fluid is used as protection during excavating.</p>	
1.2.3	Diaphragm walling equipment using milling cutters	<p>Truck- or crawler-mounted machine equipped with a milling unit to cut a trench in the ground, with a stabilizing fluid as protection during milling; milling dust is removed from the trench by a pumping system incorporated in the milling unit.</p> <p>NOTE — Concrete diaphragm walls or cut-off walls may be formed in such trenches.</p>	 <p style="text-align: center;">Figure 10</p>
1.3	Pile forming rig	Machine designed for making piles formed in boreholes after rotary and stroke drilling, with or without removal of ground from tube interior where piles are formed with the use of encasing tubes.	See figures 11 to 16.
1.3.1	Drilling pile forming rig	Drilling rig used in forming cast-in-place piles in holes drilled with the use of withdrawable casing.	See figures 11 and 12.

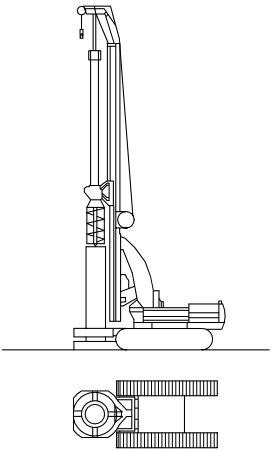
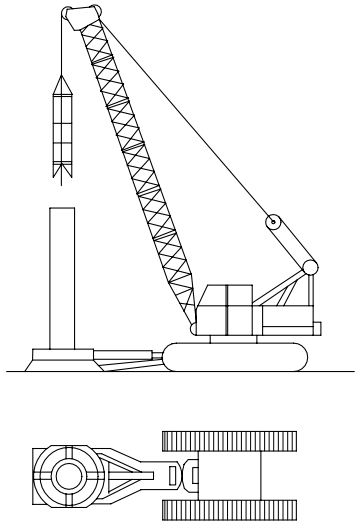
Item	Term	Definition	Illustration
1.3.1.1	Rig for rotary drilling and installation of withdrawable casing	<p>Truck- or crawler-mounted machine, equipped with a guiding tower, a rotary drilling unit and a device for installation and extraction of the casing.</p> <p>NOTE — The equipment is used for making piles by placing concrete in a borehole with simultaneous recovery of the tube employed as casing.</p>	 <p style="text-align: center;">Figure 11</p>
1.3.1.2	Rig for stroke drilling and installation of withdrawable casing	<p>Truck- or crawler-mounted machine, equipped with a rope-operated or rod-mounted grab bucket for stroke drilling, and with a device for installation of temporary casing.</p> <p>NOTE — The equipment serves to form piles by placing concrete in a borehole, with simultaneous recovery of the tube employed as the casing.</p>	 <p style="text-align: center;">Figure 12</p>
1.3.2	Rig for uncased drilling for cast-in-place piles		See figures 13 to 15.

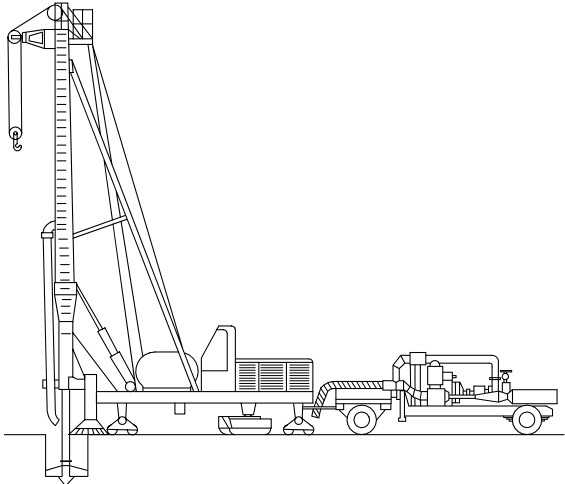
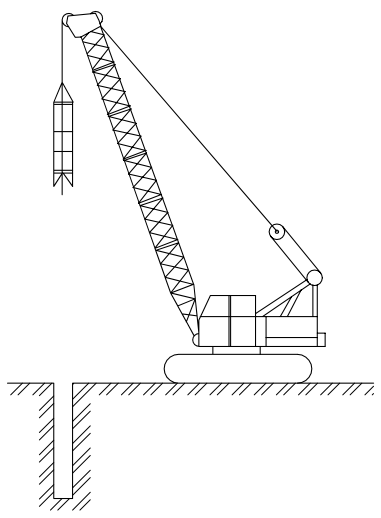
Item	Term	Definition	Illustration
1.3.2.1	Rig for rotary drilling with stabilizing fluid	<p>Truck- or crawler-mounted machine, furnished with a guiding mast, rotary drilling unit, hollow rod and a drilling mud pumping unit for continuous removal of drillings from boreholes.</p> <p>NOTE — The equipment is used for forming piles by placing concrete in holes protected by a stabilizing fluid during drilling.</p>	 <p style="text-align: center;">Figure 13</p>
1.3.2.2	Rig for stroke drilling with stabilizing fluid	<p>Truck- or crawler-mounted machine, equipped with a rope-operated or rod-mounted grab bucket for stroke drilling.</p> <p>NOTE — The equipment is used to form piles by placing concrete in holes protected by a stabilizing fluid during drilling.</p>	 <p style="text-align: center;">Figure 14</p>

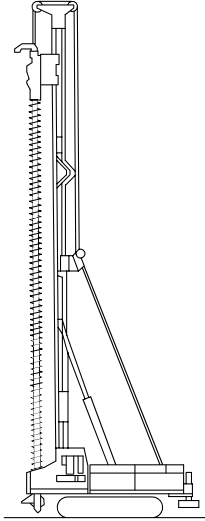
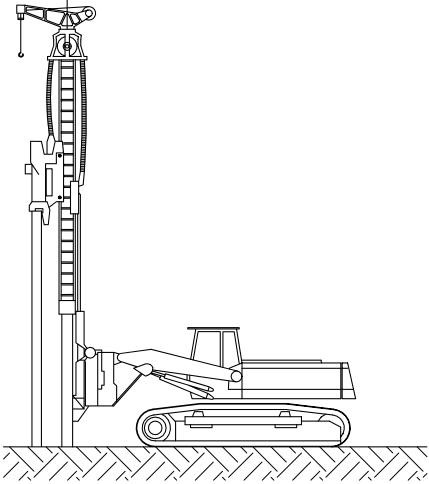
Item	Term	Definition	Illustration
1.3.2.3	Rig for rotary drilling with a continuous-flight auger	<p>Truck- or crawler-mounted machine, with a guiding tower and drilling unit moving along the guides.</p> <p>NOTE — The equipment is used for drilling of holes by a single passage of long auger and for formation of piles by placing concrete in the holes. Concrete is fed through the drilling head and hollow auger, filling the hole while the auger is being withdrawn.</p>	 <p style="text-align: center;">Figure 15</p>
1.3.2.4	Multipurpose pile driving and extracting equipment	<p>Hydraulic carrier machine (usually hydraulic excavator) equipped with telescopic leader system designed to fix quickly the following attachment:</p> <ul style="list-style-type: none"> — vibratory pile drivers, — static pile pushing and pulling device, — rotary drilling with continuous flight auger, — impact hammer (hydraulic or diesel). 	 <p style="text-align: center;">Figure 16</p>

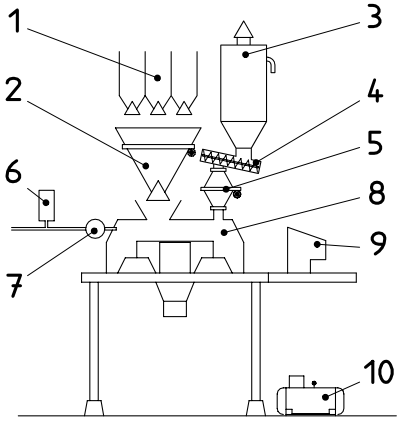
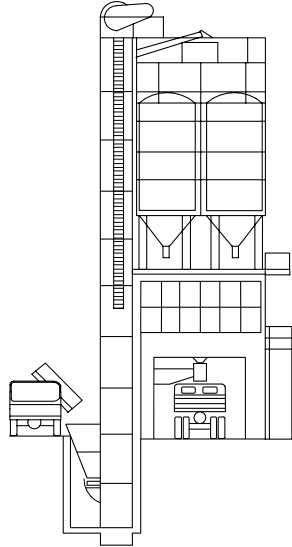
Item	Term	Definition	Illustration
<p>2 Equipment for preparing, conveying and compaction of concrete, mortar and processing reinforcement</p>			
2.1	Machines and equipment for concrete mix production	Machines and equipment designed for storing, proportioning and mixing concrete.	See figures 17 to 27.
2.1.1	Concrete mixing plant	<p>Set of equipment for concrete mix production.</p> <p>NOTE — Aggregate storage bins are located at the side of the mixer.</p>	 <p>Key</p> <ul style="list-style-type: none"> 1 Aggregate storage bins 2 Aggregate weighing unit 3 Cement silo 4 Cement conveyor 5 Cement weighing unit 6 Admixture dosage unit 7 Water dosage unit 8 Mixer 9 Electric control system 10 Pneumatic system <p>Figure 17</p>
2.1.1.1	Vertical (tower) concrete mixing plant	Equipment for the production of concrete mix, characterized by the location of aggregate storage bins above the mixer.	 <p>Figure 18</p>

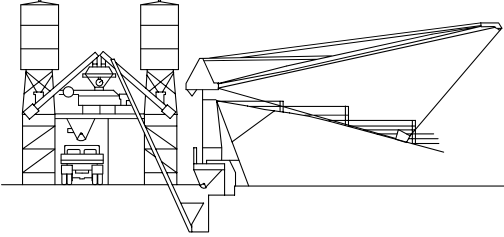
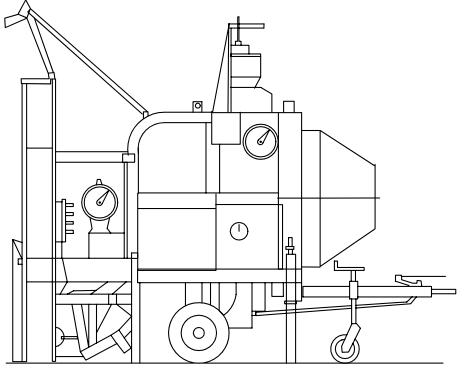
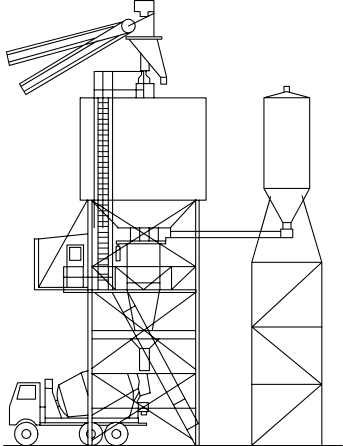
Item	Term	Definition	Illustration
2.1.1.2	Horizontal concrete mixing plant	<p>Set of machines and equipment for the production of concrete mix, characterized by the location of aggregate storage bins or an active storage arrangement at the side of the mixer.</p> <p>NOTE — In some types of the horizontal concrete mixing plant, the aggregate feeding skip also serves as a weighing hopper. Instead of an aggregate storage yard with a retaining wall, there may be aggregate bins with a belt or a scraper conveyor feeding aggregate directly to the batcher.</p>	 <p style="text-align: center;">Figure 19</p>
2.1.1.3	Stationary concrete mixing plant	Concrete mixing plant constructed for permanent location.	See figures 18 and 19.
2.1.1.4	Transferable concrete mixing plant	Concrete mixing plant capable of relocation by dismantling for transportation and reassembling.	See figures 18 and 19.
2.1.1.5	Mobile concrete mixing plant	<p>A trailer-mounted concrete mixing plant.</p> <p>NOTE — Only the horizontal types of plant appear in this group.</p>	 <p style="text-align: center;">Figure 20</p>
2.1.2	Concrete mix batching plant	Machines and equipment for proportioning of aggregate, cement and water, or for dry constituents only and for loading them on road transport.	See figures 21 and 22.
2.1.2.1	Vertical concrete mix batching plant	<p>Machines and equipment for proportioning the constituents and for loading mixed concrete into transport vehicles.</p> <p>NOTE — Aggregate storage bin is located above the batcher and the vehicle being loaded.</p>	 <p style="text-align: center;">Figure 21</p>

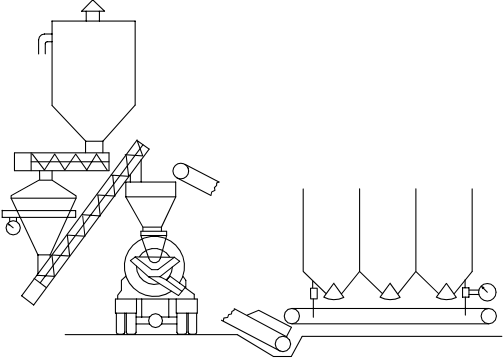
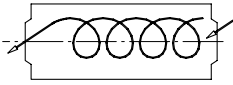
Item	Term	Definition	Illustration
2.1.2.2	Horizontal concrete mix batching plant	<p>Set of machines and equipment for proportioning constituents and for loading concrete mix into transport vehicles.</p> <p>NOTE 1 — The aggregate storage bin is located at the side of the charging (feeding) hopper.</p> <p>NOTE 2 — The horizontal batching plant may also be designed:</p> <ul style="list-style-type: none"> — in a layout similar to the horizontal concrete mixing plant, including storage yard with a retaining wall (see 1.1.2); — with direct aggregate feed to the batcher by a scraping conveyor, i.e. without aggregate storage bins. 	 <p style="text-align: center;">Figure 22</p>
2.1.2.3	Stationary concrete batching plant	Concrete mix batching plant without capability for relocation.	See figures 21 and 22.
2.1.2.4	Transferable concrete batching plant	A plant for proportioning concrete mix constituents, capable of relocation by stripping for transportation and reassembling.	See figures 21 and 22.
2.1.3	Concrete mixers	<p>Machines designed for the production of concrete by mixing of measured (by mass or volume) proportions of water, cement, aggregate and possibly chemical additives, within a certain time limit.</p> <p>NOTE — A concrete mixer may be furnished with the following accessories: charging skip hoist, fixed or wheeled supporting frame, mechanical shovel, water dosing equipment, and a skip weighing system.</p>	See figures 23 to 27.
2.1.3.1	Batch-type concrete mixer	Mixer in which charging with concrete constituents and discharging of the drum are carried out periodically, in batches.	See figures 24 to 27.
2.1.3.2	Continuous-type concrete mixer	Mixer in which charging with concrete constituents and discharging of the drum are carried out continuously as an uninterrupted flow.	 <p style="text-align: center;">Figure 23</p>
2.1.3.3	Gravity concrete mixer (Free-fall concrete mixer)	Machine where mixing is effected by repeatedly elevating the mixed concrete and dropping it from a certain height, inside a mixing drum, during its rotation.	See figures 24 and 25.

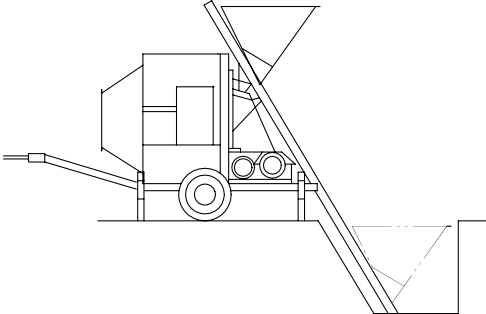
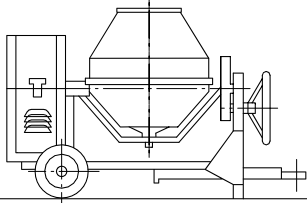
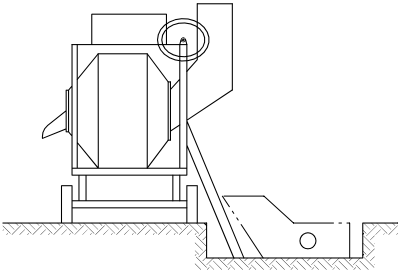
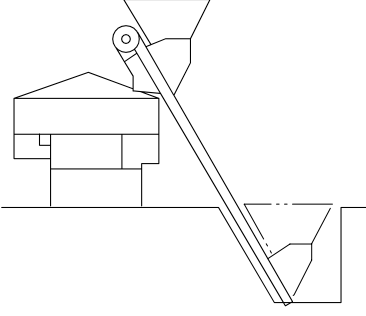
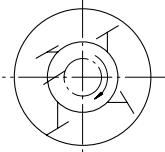
Item	Term	Definition	Illustration
2.1.3.3.1	Reversing (drum) concrete mixer	Gravity mixer with a reversible direction of rotation of the mixing drum; discharge of mixed concrete is by reversing the rotation of the drum.	 <p style="text-align: center;">Figure 24</p>
2.1.3.3.2	Tipping drum concrete mixer	Free-fall mixer with a tipping mixing drum, open at one end for charging and discharging of the concrete mix; discharging is carried out by tilting the drum.	 <p style="text-align: center;">Figure 25</p>
2.1.3.3.3	Discharging chute concrete mixer	Free-fall mixer, with a mixing drum open at both sides; charging is carried out from one side and discharging from the other by means of a chute entering the drum.	 <p style="text-align: center;">Figure 26</p>
2.1.3.4	Compulsory concrete mixer	Machine with mixing effected by the action of one or more agitators moving inside a mixing chamber with either a vertical (pan) or horizontal axis (trough). NOTE — The illustrations of individual compulsory mixer types shown in figures 28 to 34 depict the pattern movement of the agitators.	 <p style="text-align: center;">Figure 27</p>
2.1.3.4.1	Turbo concrete mixer	Compulsory concrete mixer with an agitator rotating about the vertical axis of a stationary pan, charged from the top and discharged by opening a segment of the pan bottom.	 <p style="text-align: center;">Figure 28</p>

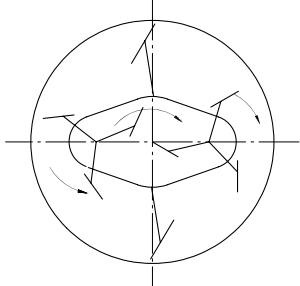
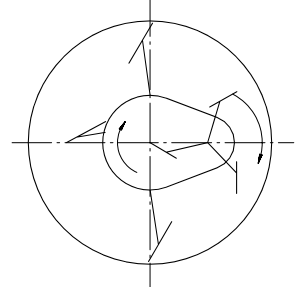
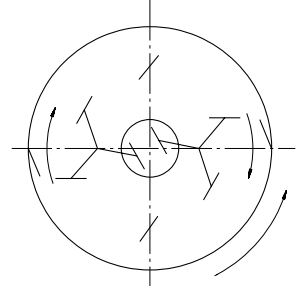
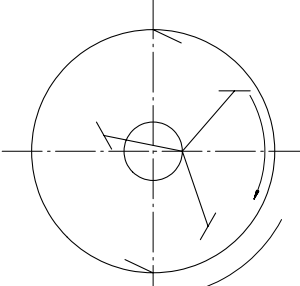
Item	Term	Definition	Illustration
2.1.3.4.2	Planetary concrete mixer	Compulsory mixer with vertically mounted agitators having a planetary type of motion, inside a stationary pan; the mixer is charged from the top, and discharged by opening a segment of the pan bottom.	 <p style="text-align: center;">Figure 29</p>
2.1.3.4.3	Turbo planetary concrete mixer	Compulsory mixer having one agitator rotating about the vertical axis of a stationary pan in addition to other agitators in planetary motion; the mixer is charged from the top and discharged by opening a segment of the pan bottom.	 <p style="text-align: center;">Figure 30</p>
2.1.3.4.4	Counter-current operation concrete mixer	Forced-action mixer with one or more agitators rotating about the vertical axes in a counter-rotating pan; the mixer is charged from the top and discharged by opening a segment of the pan bottom.	 <p style="text-align: center;">Figure 31</p>
2.1.3.4.5	Concurrent operation concrete mixer	Compulsory mixer with one or more agitators rotating about vertical axes in a pan rotating concurrently; the mixer is charged from the top and discharged by opening a segment of the pan bottom	 <p style="text-align: center;">Figure 32</p>

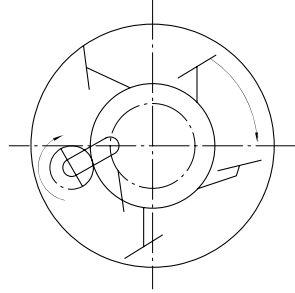
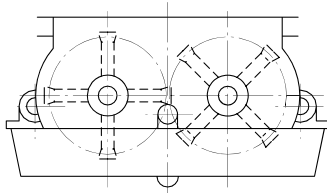
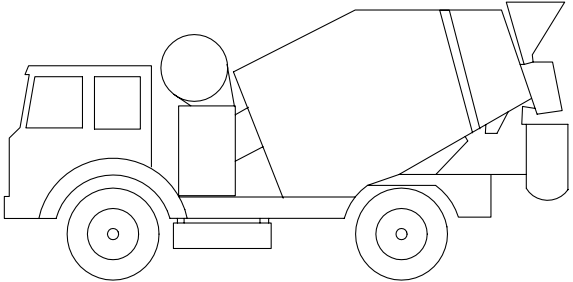
Item	Term	Definition	Illustration
2.1.3.4.6	Concrete mixer with high-speed stirrer (activator)	Compulsory mixer with one or more agitators rotating about vertical axes including one high speed agitator (activator); the mixer is charged from the top and discharged by opening a segment of the pan bottom.	 <p style="text-align: center;">Figure 33</p>
2.1.3.4.7	Paddle mixer	Compulsory mixer with one or two paddle agitators rotating about horizontal axis in a casing (trough); the mixer is charged from the top and discharged by opening a segment of the pan bottom. NOTE — The paddles may be straight or helix-edged.	 <p style="text-align: center;">Figure 34</p>
2.2	Machinery and equipment for transporting concrete mix	Machinery and equipment designed for conveying concrete mix from the production to the construction site.	See figures 35 to 50.
2.2.1	Means of wheeled transport of concrete mix	Revolving or open-top containers with or without agitators, mounted on trucks or trailers.	See figures 35 to 37.
2.2.1.1	Truck mixer	Concrete mixing unit mounted on a self-propelled chassis or trailer and capable of producing and delivering homogeneously mixed concrete. NOTE — It is usually a free-fall, reversing gravity mixer with a pear-shaped drum inclined at angle of approximately 15° to the horizontal. Additional equipment includes a water tank and water dosage unit, charge hopper and discharging chute.	 <p style="text-align: center;">Figure 35</p>

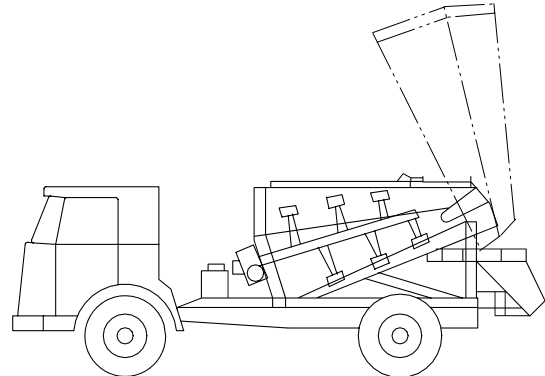
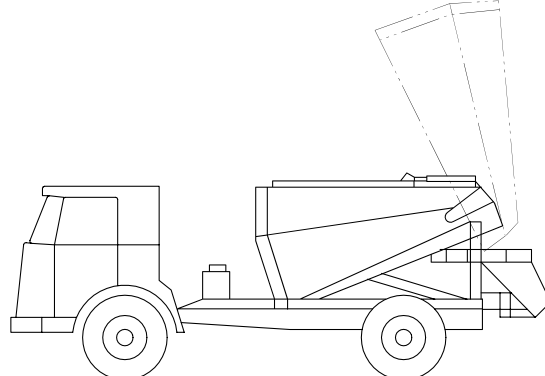
Item	Term	Definition	Illustration
2.2.1.2	Concrete transport skip (agitating equipment)	Equipment normally mounted on a self-propelled chassis and capable of maintaining fresh concrete in a thoroughly mixed and homogeneous state during transport.	 <p style="text-align: center;">Figure 36</p>
2.2.1.3	Concrete transport skip (non-agitating equipment)	Equipment used for transporting concrete without agitation; for example, dump truck or transport hopper.	 <p style="text-align: center;">Figure 37</p>

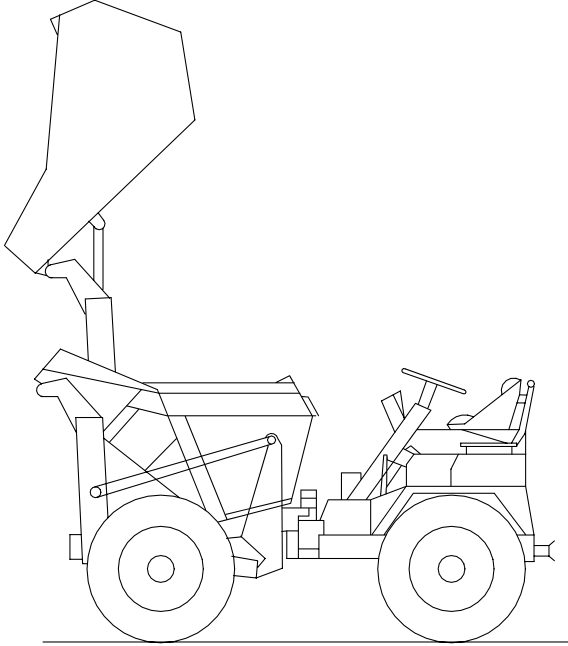
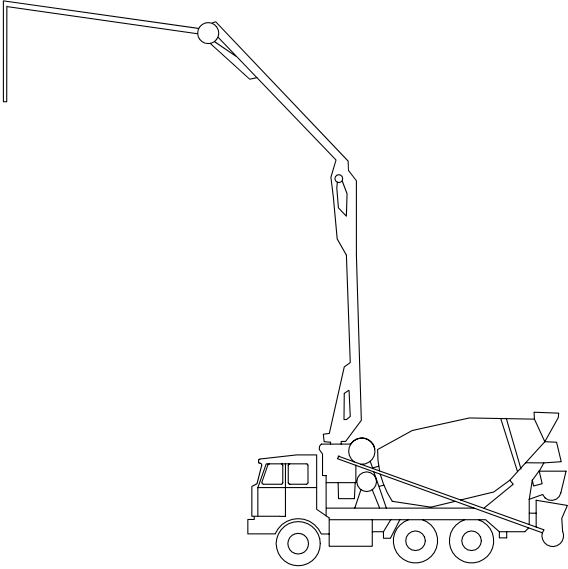
Item	Term	Definition	Illustration
2.2.1.4	Concrete dumper	<p>Open-top tank, tapered towards the discharge end and mounted on a four-wheel, self-propelled undercarriage; the tank is emptied by tilting to the front or to one or both sides, or by lifting and tilting.</p>	 <p style="text-align: center;">Figure 38</p>
2.2.1.5	Truck mixer with concrete pump	<p>A truck-mounted concrete mixer with pump.</p>	 <p style="text-align: center;">Figure 39</p>

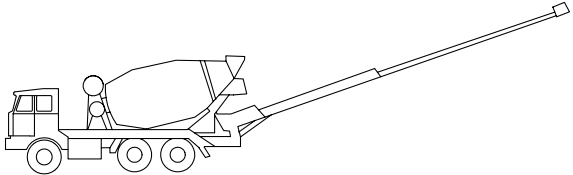
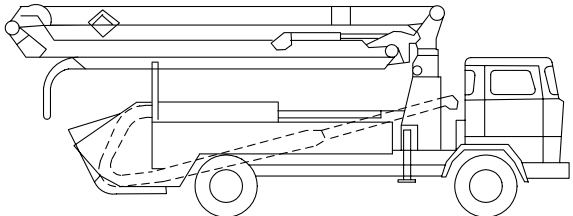
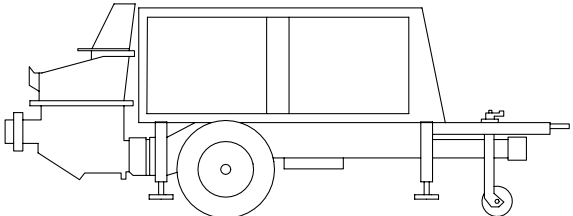
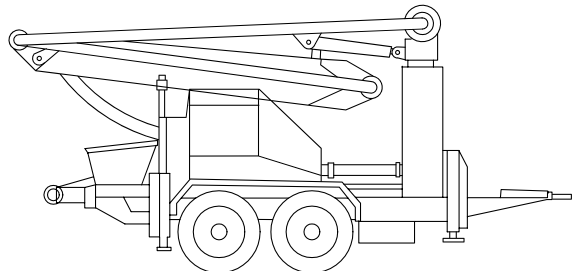
Item	Term	Definition	Illustration
2.2.1.6	Truck mixer with belt conveyor	Truck-mounted concrete mixer with belt conveyor.	 <p style="text-align: center;">Figure 40</p>
2.2.2	Concrete mix delivery equipment	Equipment for the distribution of concrete mix, using pumps or pneumatic devices, pipes or flexible hoses.	See figures 41 to 50.
2.2.2.1	Concrete pump	Machine designed for delivering concrete mix, using pumps and various conduits.	See figures 41 and 42.
2.2.2.1.1	Mobile concrete pump	Truck-mounted concrete pump.	 <p style="text-align: center;">Figure 41</p>
2.2.2.1.2	Trailer concrete pump	Trailer-mounted concrete pump.	 <p style="text-align: center;">Figure 42</p>
2.2.2.1.3	Concrete pump with a distributing boom	<p>Concrete pump equipped with a distributing boom to deliver concrete mix to work areas within reach of the boom.</p> <p>NOTE — The pump may be also used for pumping concrete directly into a connected pipeline.</p>	 <p style="text-align: center;">Figure 43</p>

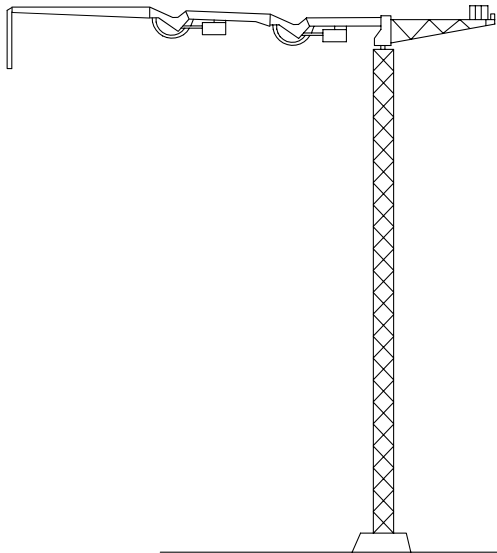
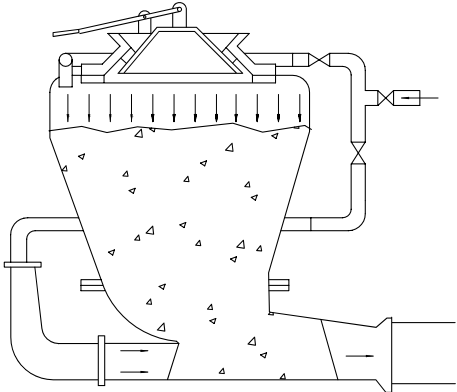
Item	Term	Definition	Illustration
2.2.2.1.4	Concrete pump without a placing boom	Concrete pump delivering concrete via a pipeline and not equipped with a placing boom.	See figure 42.
2.2.2.2	Tower-mounted distributing boom	Placing boom with articulated joints and a delivery pipe attached to it, and which rotates about the vertical axis, the end section of the delivery pipe is flexible; the angle of boom rotation in the vertical plane (elevation) is almost 360°.	 <p style="text-align: center;">Figure 44</p>
2.2.2.3	Pneumatic concrete placing device	Device for pipe transport of concrete mix using compressed air.	See figures 45 and 46.
2.2.2.3.1	Single-chamber pneumatic concrete placing device	Pear-shaped, sealed vessel with compressed air fed alternately to the space above its charge of concrete mix and to the bottom part, in order to produce a surge of mix into the delivery pipe.	 <p style="text-align: center;">Figure 45</p>

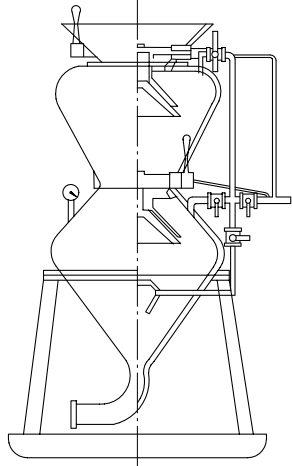
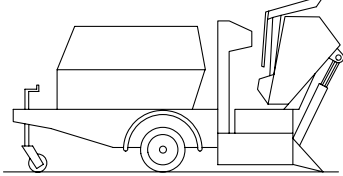
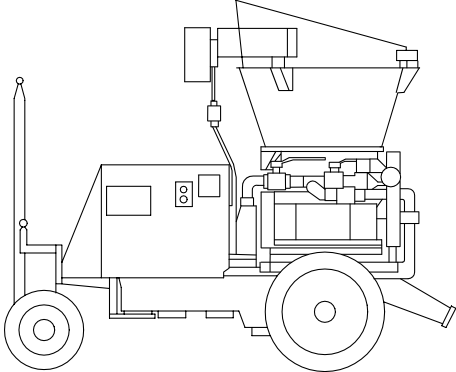
Item	Term	Definition	Illustration
2.2.2.3.2	Twin-chamber pneumatic concrete placing device	Feeder comprising a charging and a working chamber; the charging chamber is filled by discharge of concrete mix from the working chamber; the pneumatic system operates in a similar way as the single-chamber conveyor.	 <p style="text-align: center;">Figure 46</p>
2.2.2.3.3	Feeder of fresh concrete and mortar	Equipment for mixing and pneumatic conveying of floor screed concrete and bulk material as well as harsh mix.	 <p style="text-align: center;">Figure 47</p>
2.2.2.4	Concrete spraying machine	Machine for spraying concrete on walls and floors, and which operates by feeding separate flows of cement and aggregate, carried by compressed air in a flexible hose, and of water under appropriate pressure to a spraying nozzle; the constituents are mixed in the nozzle.	 <p style="text-align: center;">Figure 48</p>
2.2.3	Concrete mix transfer vessels	Open container type equipment for the temporary storage and transport by cranes of concrete mix on construction sites.	See figures 49 and 50.

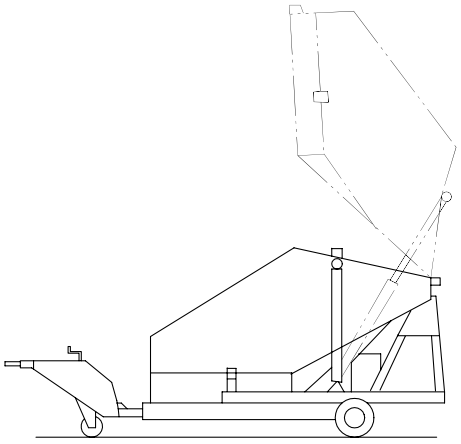
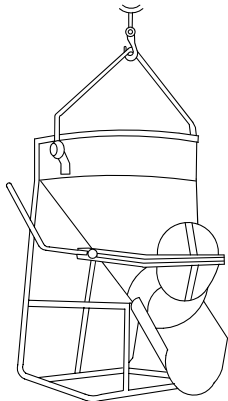
Item	Term	Definition	Illustration
2.2.3.1	Concrete mix transfer tank	<p>Transportable tank of a shape converging towards the discharge end, equipped with an unloading mechanism for transfer of concrete mix on construction sites.</p> <p>NOTE — It is usually operated in two positions:</p> <ul style="list-style-type: none"> — low for charging, — upright for discharging. 	 <p style="text-align: center;">Figure 49</p>
2.2.3.2	Concrete bucket	Hopper-like vessel with a discharge mechanism, designed for handling concrete mix using cranes.	 <p style="text-align: center;">Figure 50</p>
2.3	Machines and equipment for placing concrete mix	Machines and equipment designed for compacting, vacuum treatment, levelling or shaping the concrete components for structures.	See figures 51 to 57.
2.3.1	Vibrator for compacting concrete mix	Machine for compacting concrete using vibration.	See figures 51 to 55.
2.3.1.1	Internal vibrators	Vibrator (poker) designed for immersion in the concrete mix to effect its compaction.	See figures 51 and 52.

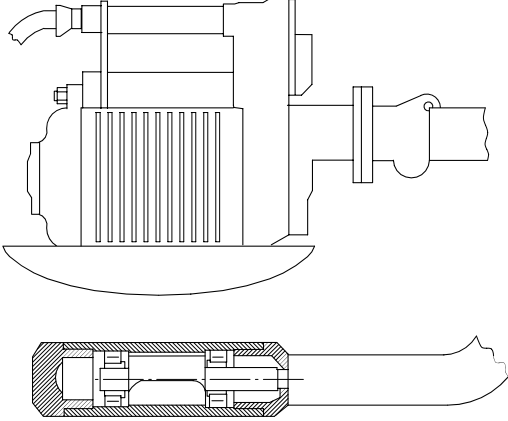
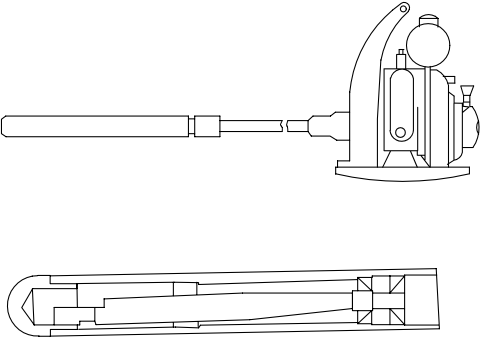
Item	Term	Definition	Illustration
2.3.1.1.1	Eccentric-type immersion vibrator	<p>Immersion vibrator using the eccentricity of a mass rotating inside its casing in bearings to produce harmonic vibration for compacting concrete.</p> <p>NOTE — Vibrators may have various drives, for example, electric, IC-engine, pneumatic or hydraulic drive. An immersion vibrator with an electric drive may have an electric motor enclosed in its body (poker) or a power unit composed of an electric motor and a frequency converter.</p>	 <p style="text-align: center;">Figure 51</p>
2.3.1.1.2	Pendulum-type (p-t) immersion vibrator	<p>Vibrator similar to 2.3.1.1.1, but with a pendulum mechanism generating vibrations by rotating an out-of-balance mass along a circular path. Most p-t vibrators are driven by electric motor or IC engines.</p>	 <p style="text-align: center;">Figure 52</p>

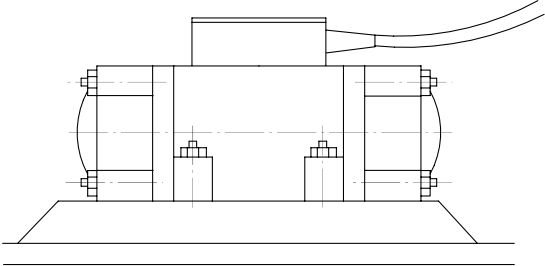
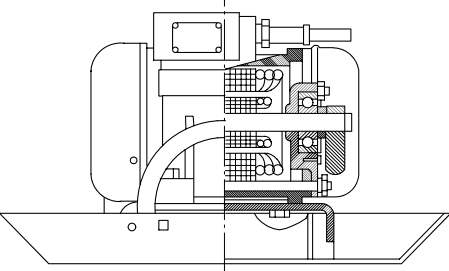
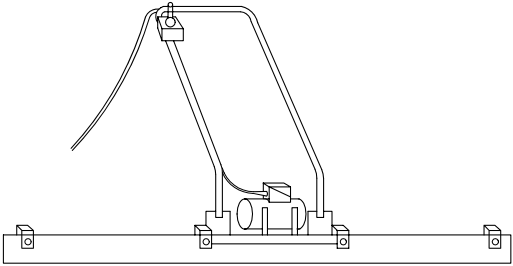
Item	Term	Definition	Illustration
2.3.1.2	External vibrator	<p>Vibrator using either an eccentric or pendulum working principle and which is attachable to external elements of building construction equipment (e.g. wall of a form) to cause compaction of the concrete mix.</p> <p>NOTE — It is powered mostly by electric, pneumatic or hydraulic drive.</p>	 <p style="text-align: center;">Figure 53</p>
2.3.1.3	Surface vibrator	<p>Vibrator having a plate with an eccentric or pendulum-type vibration generator, designed for simultaneously compacting and floating the surface of the concrete mix.</p>	 <p style="text-align: center;">Figure 54</p>
2.3.1.4	Vibrating beam	<p>Device for compacting and levelling the surface of fresh concrete, in the form of a beam with a mechanical vibrator attached to it.</p>	 <p style="text-align: center;">Figure 55</p>

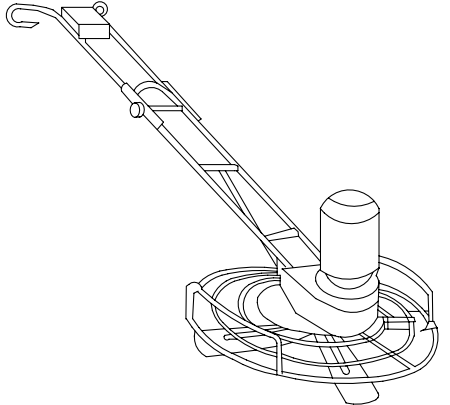
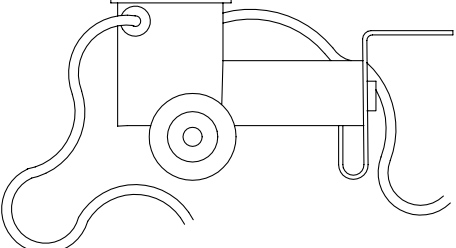
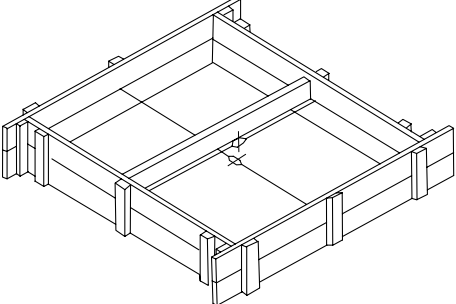
Item	Term	Definition	Illustration
2.3.2	Floating machine	Machine designed to float on floor surfaces made from fresh concrete, cement, mortar or other suitable mineral materials.	 <p data-bbox="1161 696 1273 725">Figure 56</p>
2.3.3	Mechanical trowel	For description refer to 2.4.5.	
2.3.4	Concrete vacuum treatment unit	<p data-bbox="459 797 963 853">Device for the removal of water and air from a concrete mix by a vacuum process.</p> <p data-bbox="459 864 963 1010">NOTE — The basic components of the unit are: vacuum pump with drive, vacuum reservoir and (only in units equipped with a rotating liquid ring vacuum pump) water tank. The surface of the concrete is covered with a mat during the vacuum process.</p>	 <p data-bbox="1161 1077 1273 1106">Figure 57</p>
2.3.5	Formwork for monolithic structural elements made of concrete or reinforced concrete	Equipment comprising form lining, supporting and joining elements used in casting concrete and reinforced concrete structures, to maintain the desired shape, to support reinforcements and to contain the concrete mix until it settles to the desired strength.	See figures 58 to 67.
2.3.5.1	Job-specific formwork	Timber formwork made on site to the particular needs of concrete or reinforced concrete casting for non-repeatable jobs.	 <p data-bbox="1161 1659 1273 1688">Figure 58</p>

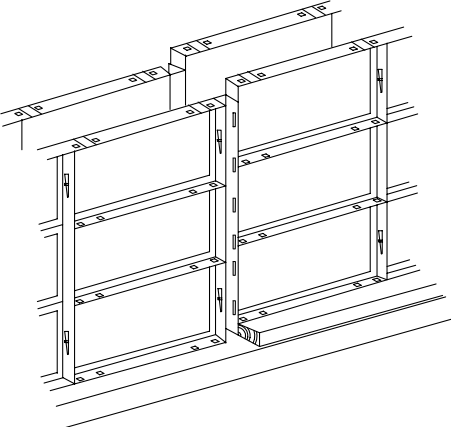
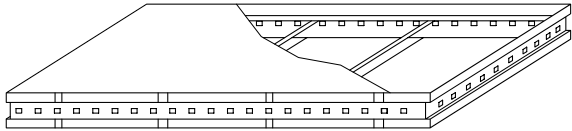
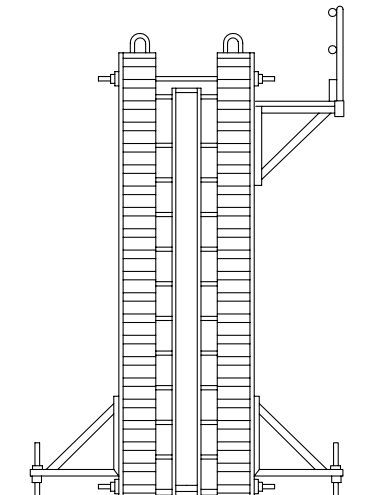
Item	Term	Definition	Illustration
2.3.5.2	Universal formwork	Formwork suitable for repeated use on different kinds of monolithic structural elements.	 <p data-bbox="1193 719 1305 748">Figure 59</p>
2.3.5.2.1	Small-size formwork	Formwork for structural elements of low repeatability of shape (such as straight and offset walls, floors, structural frames and foundations), suitable for assembling and disassembling by hand.	 <p data-bbox="1145 1084 1257 1113">Figure 60</p>
2.3.5.2.2	Large-size formwork	Formwork suitable for assembling and disassembling by crane.	 <p data-bbox="1193 1659 1305 1688">Figure 61</p>

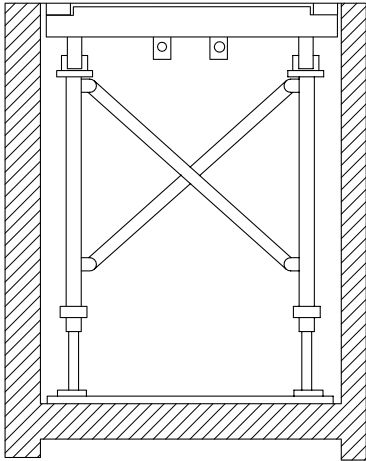
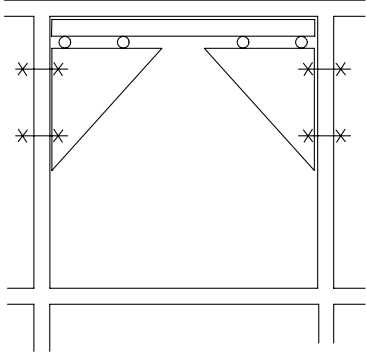
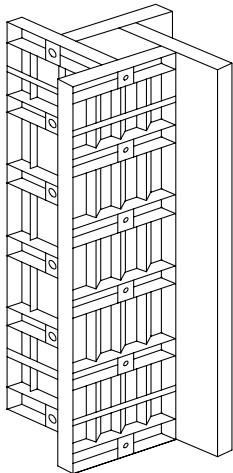
Item	Term	Definition	Illustration
2.3.5.2.3	Table formwork	Formwork for casting slab floors, the unit consisting of a plate and supporting structure which is transportable by crane.	 <p style="text-align: center;">Figure 62</p>
2.3.5.2.4	Drawer-type formwork	Formwork for casting slab floors, composed of a plate and brackets fixed to the walls of a building, allowing the plate to be slid out during disassembly.	 <p style="text-align: center;">Figure 63</p>
2.3.5.2.5	Special formwork	Formwork suitable for some characteristic shapes of elements of buildings (e.g. circular tanks, columns and poles, flights of stairs, etc.).	 <p style="text-align: center;">Figure 64</p>

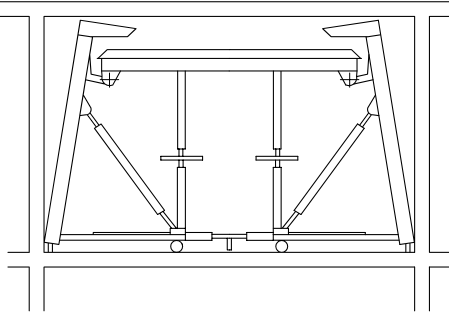
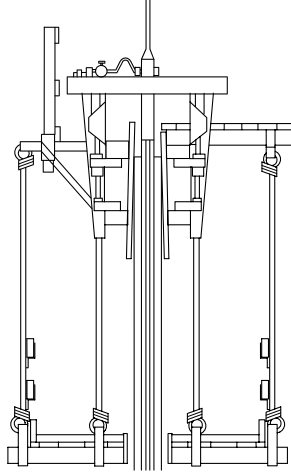
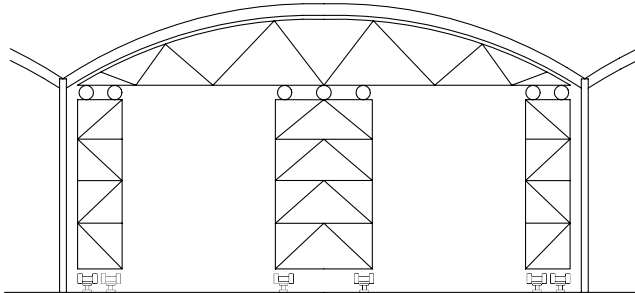
Item	Term	Definition	Illustration
2.3.5.3	Tunnel formwork	<p>Large-size, collapsible formwork for simultaneous casting of walls and crown, consisting of three hinged plates: a top one and two side ones.</p> <p>NOTE — Also the "semi-tunnel" formwork, comprising a top plate and a single side plate, belongs to this category.</p>	 <p style="text-align: center;">Figure 65</p>
2.3.5.4	Sliding (climbing) formwork	<p>Formwork capable of climbing on the surface of a structure in a continuous manner (without dismantling) and usually supported on vertical rods or steel guides fixed to the walls or located close to the structure.</p> <p>NOTE — It is used mainly in the construction of tall buildings, or their parts, such as chimneys, columns, silos and other structures of uniform cross-section along their height.</p>	 <p style="text-align: center;">Figure 66</p>
2.3.5.5	Shifting formwork	<p>Formwork shifted horizontally from one section of a structure to another after the first section of concrete has settled, and which is integral with a supporting scaffold which moves along with the form.</p> <p>NOTE — It is used in the construction of structures such as halls, tunnels and channels of considerable length.</p>	 <p style="text-align: center;">Figure 67</p>
2.4	Machines for plastering	Machines designed for plaster work including the preparation, feeding and rendering of mortar on walls and ceilings.	See figures 68 to 70.

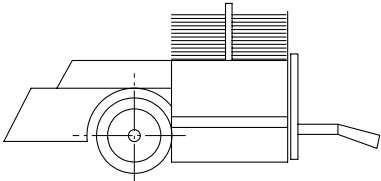
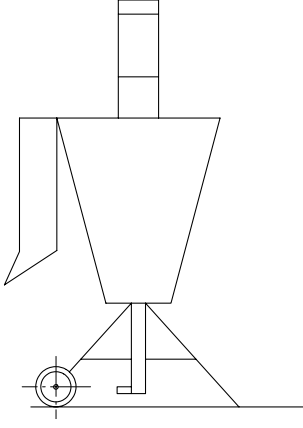
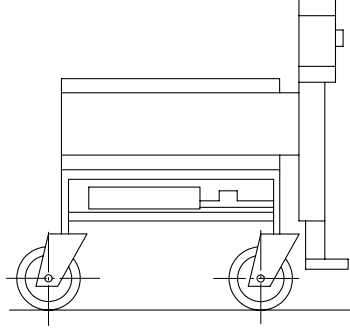
Item	Term	Definition	Illustration
2.4.1	Plastering unit	<p>Machine designed for the preparation (mixing and/or straining), feeding and rendering of mortars.</p> <p>NOTE — A plastering unit consists, at least, of a mortar reservoir, a pump with a power unit, and distribution hoses with spraying guns.</p>	See figures 68 to 70.
2.4.1.1	Plastering unit for cement-lime mortars	Plastering unit designed for carrying out plaster work using lime, cement and cement-lime mortars.	 <p style="text-align: center;">Figure 68</p>
2.4.1.2	Spraying unit for plaster-like coats	Spraying unit designed for carrying out plaster work using plaster-like mortars (PVC mortars) applied as thin finishing coats.	 <p style="text-align: center;">Figure 69</p>
2.4.1.3	Plastering unit for gypsum mortars	Plastering unit designed for carrying out plaster work using gypsum mortars.	 <p style="text-align: center;">Figure 70</p>

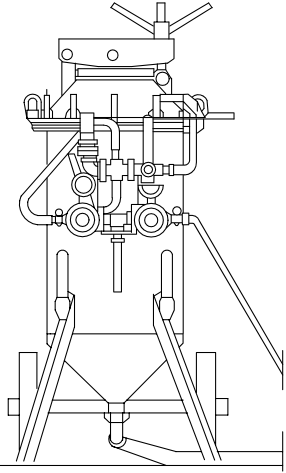
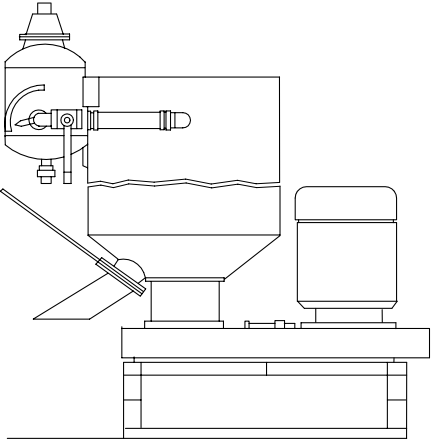
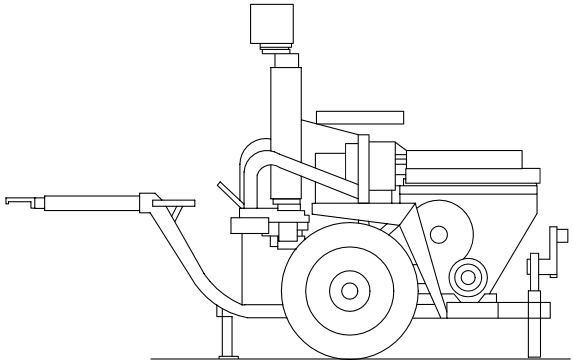
Item	Term	Definition	Illustration
2.4.2	Mortar rendering unit	<p>Equipment designed for feeding and spraying of plaster-like mortars or putty.</p> <p>NOTE — A mortar rendering unit consists of, at least, a pressure vessel with compressed air to feed the mortar, a pressure hose and a spraying gun.</p>	 <p style="text-align: center;">Figure 71</p>
2.4.3	Mortar mixer	<p>Machine for mixing mortar components.</p> <p>NOTE — There are a large variety of design types. For preparing mortar, some similar types of concrete mixer may also be used.</p>	 <p style="text-align: center;">Figure 72</p>
2.4.4	Mortar feeder	<p>Equipment for feeding mortar, mainly for floor screeds from ground level to another level.</p>	 <p style="text-align: center;">Figure 73</p>
2.4.5	Float finish device	<p>Machine performing float finish of mortar applied on plastered surfaces.</p>	

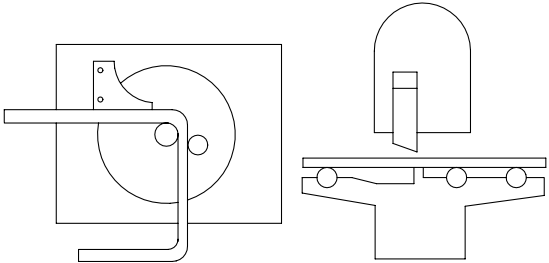
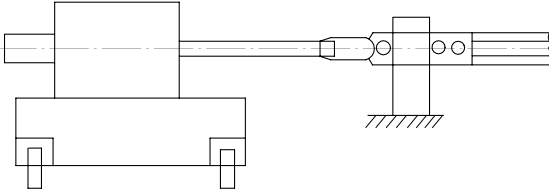
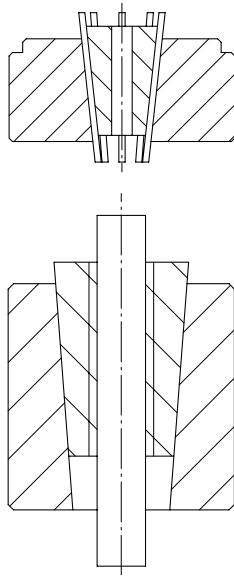
Item	Term	Definition	Illustration
2.5	Machines and installations for working concrete reinforcing steel	Machines and installations designed for straightening steel bars and for cutting and bending steel bars and mesh for concrete reinforcing.	 <p style="text-align: center;">Figure 74</p>
2.6	Machines and plant for the production of prestressed concrete elements	Complete plants, prestressing jacks and slideformers designed for the production of prestressed concrete elements.	 <p style="text-align: center;">Figure 75</p>
2.6.1	Anchor grips for wires, cables and bars used in pre-stressed and post-tensioned concrete	<p>Anchor grips for prestressed concrete:</p> <p>Equipment for the production of prestressed concrete elements that ensures anchoring and maintains a prestressing force in wires or cables during the production process.</p> <p>Anchor grips for post tensioned concrete:</p> <p>An element of the post-tensioned structure which ensures the anchoring of cables or bars and maintains a tensioning force.</p>	 <p style="text-align: center;">Figure 76</p>

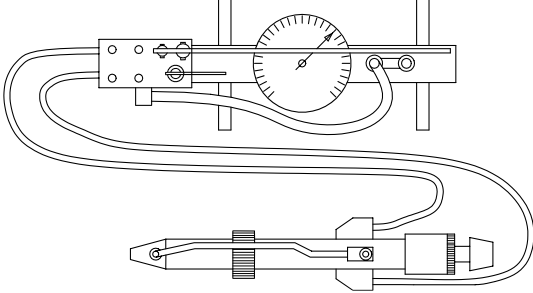
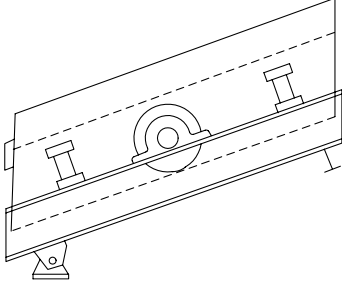
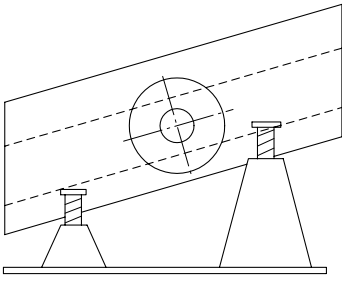
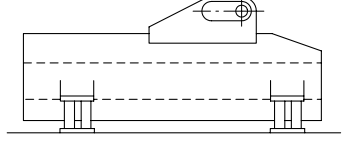
Item	Term	Definition	Illustration
2.6.2	Equipment for tensioning wires, cables and bars used in the production of pre- and post-tensioned concrete elements	Mechanical equipment and special hydraulic jack with feeders designed for tensioning and anchoring of the wires or cables on production stands of prestressed concrete elements and cables or bars used in post-tensioned concrete structures.	 <p style="text-align: center;">Figure 77</p>
3 Machines and equipment for aggregate processing			
3.1	Screening machine	Machine which grades a mixture of particles according to their dimensions.	See figures 78 to 88.
3.1.1	Vibrating screen eccentric drive (Four-bearing screen)	Screen comprising an eccentric shaft assembly with four bearings, two of which are connected to the screen box and two to the base frame, and which imparts a circular motion to the screen box.	 <p style="text-align: center;">Figure 78</p>
3.1.2	Vibrating screen with out-of-balance drive (Two-bearing screen)	Screen where a circular movement is imparted to the screen box by one or more shafts with out-of-balance weights; this shaft is connected to the screen box by two bearings.	 <p style="text-align: center;">Figure 79</p>
3.1.3	Vibrating screen with double (or more) out-of-balance drive	Screen where a linear or elliptical motion is imparted to the screen box by two (or more) shafts with out-of-balance weights which turn in opposite directions.	 <p style="text-align: center;">Figure 80</p>

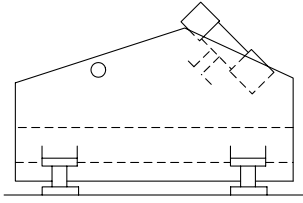
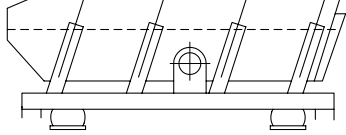
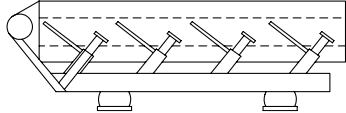
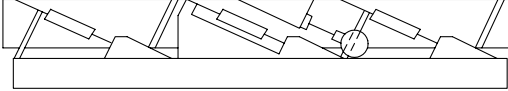
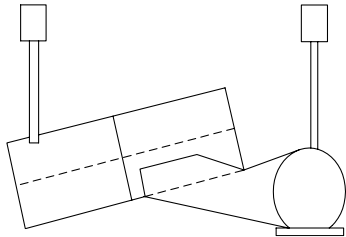
Item	Term	Definition	Illustration
3.1.4	Vibrating screen drive by out-of-balance motors	Screen where the screen box is made to move in a circular, elliptical or linear motion by one or more out-of-balance motors (vibrators) mounted on it.	 <p style="text-align: center;">Figure 81</p>
3.1.5	Elliptically vibrating screen with additional mass	Screen where the screen box is made to move in an elliptical motion by an out-of-balance mechanism, which is limited in one direction by an additional mass.	 <p style="text-align: center;">Figure 82</p>
3.1.6	Vibrating screen with push rod drive	Screen where the screen box is made to move in a linear motion by means of push rod (rods) driven by a crankshaft.	 <p style="text-align: center;">Figure 83</p>
3.1.7	Resonance screen	Screen in which the screen box is elastically connected to a counter-balancing mass (balance frame), which is itself elastically suspended; this combination forms a vibrating system in which its own frequency is very close to the working frequency; the motion is linear or elliptical, depending on the type of drive and suspension.	 <p style="text-align: center;">Figure 84</p>
3.1.8	Screening machine with electromagnetic drive	Screen in which the screen box is made to move in a linear motion by an electromagnetic drive which is fixed to it.	 <p style="text-align: center;">Figure 85</p>

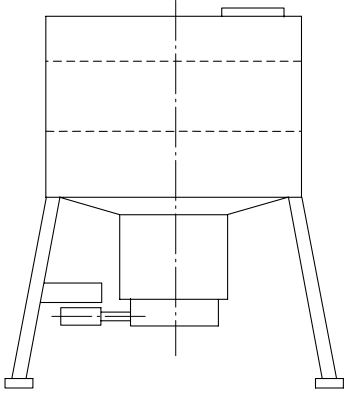
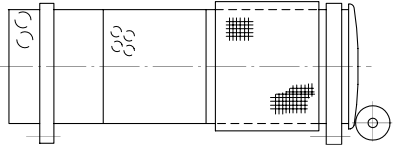
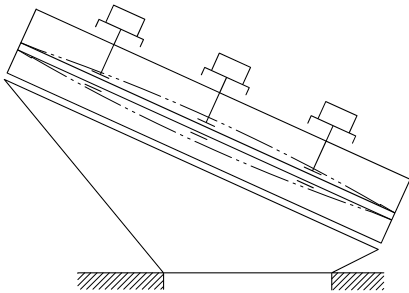
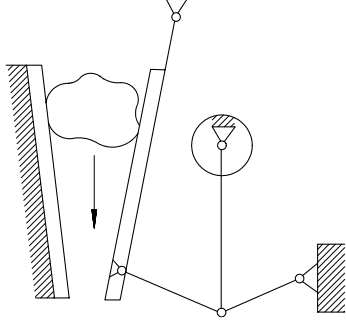
Item	Term	Definition	Illustration
3.1.9	Gyratory screen	Screen in which the screen box is made to vibrate in a circular or linear motion which is practically parallel to the screening surfaces, by means of out-of-balance weights or crank-shaft.	 <p style="text-align: center;">Figure 86</p>
3.1.10	Rotary screen	Screen whose surface is formed into a cylinder, polygon or cone shape and is rotated about its longitudinal axis, which may be horizontal or inclined.	 <p style="text-align: center;">Figure 87</p>
3.1.11	Screens with direct vibrated screen plate	Screen in which the screen panel is made to move mechanically, independently of the screen box.	 <p style="text-align: center;">Figure 88</p>
3.2	Crusher	Machine which crushes granular materials into particles of smaller dimensions.	See figures 89 to 99.
3.2.1	Jaw crusher	Compression crushing machine consisting of a fixed jaw and a movable jaw which moves so as to increase and decrease the gap between the two jaws.	See figures 89 and 90.
3.2.1.1	Double-toggle jaw crusher	Jaw crusher in which the motion of the eccentric shaft is transmitted to the jaw through the pitman and two toggle plates; each point of the mobile jaw moves through a segment of a circular path.	 <p style="text-align: center;">Figure 89</p>

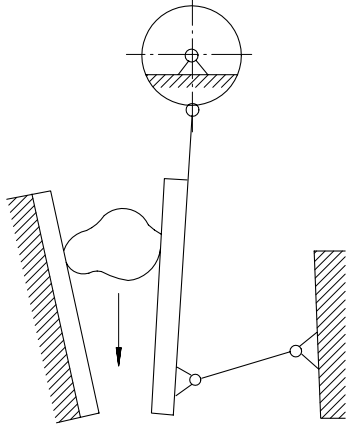
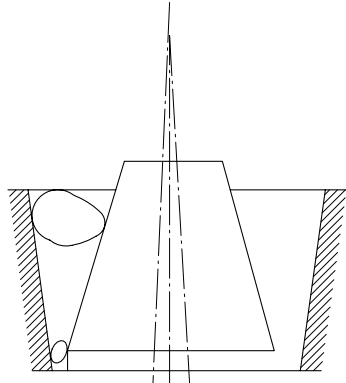
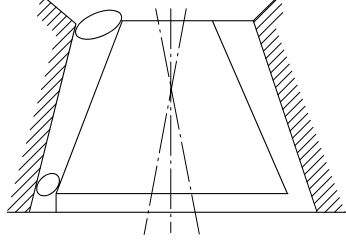
Item	Term	Definition	Illustration
3.2.1.2	Single-toggle jaw crusher	Jaw crusher in which the jaw stock is suspended from an eccentric shaft and is braced by a toggle from the back plate so that each point of the mobile jaw moves through a close curve path.	 <p style="text-align: center;">Figure 90</p>
3.2.2	Gyratory crusher/cone crusher	Compression crushing machine consisting of a moving member rotated eccentrically within the fixed member; both moving and fixed members are in a form of truncated cones.	See figures 91 and 92.
3.2.2.1	Gyratory crusher with mainly primary crushing application	Gyratory crusher in which the fixed crushing member (outer shell) is in the form of an inverted truncated cone (the upper diameter of which is greater than that at the bottom).	 <p style="text-align: center;">Figure 91</p>
3.2.2.2	Gyratory crusher/cone crusher, with mainly secondary and tertiary application	Crusher in which both moving and fixed crushing members are in the form of truncated cones of greater diameter at the bottom than at the top.	 <p style="text-align: center;">Figure 92</p>
3.2.3	Roll crusher	Crushing machine which breaks: <ul style="list-style-type: none"> a) by pressure being continuously maintained between the faces of two revolving cylinders (rolls); b) by impact, shear and pressure between one roll which has, at intervals rows of teeth and another roll or breaker plate. 	See figures 93 and 94.

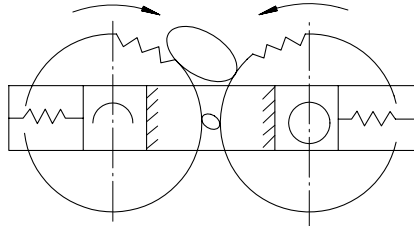
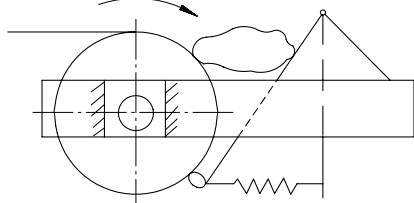
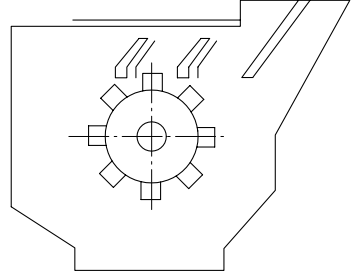
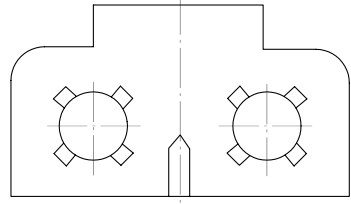
Item	Term	Definition	Illustration
3.2.3.1	Double-roll crusher	Crusher comprising two rolls having smooth, rowed or toothed outer surfaces and turning in opposite directions.	 <p style="text-align: center;">Figure 93</p>
3.2.3.2	Single-roll sledging crusher	Crusher comprising a roll having a toothed outer surface and a breaker plate hinged at the top and secured by an adjustable anchorage.	 <p style="text-align: center;">Figure 94</p>
3.2.4	Impact crusher hammer mill	Crushing machine in which material is fragmented by kinetic energy imparted into the feed material against a fixed surface.	See figures 95 to 99.
3.2.4.1	Solid-rotor impact breaker	Crusher comprising one or two solid rotors equipped with replaceable liner plates.	See figures 95 and 96.
3.2.4.1.1	Single-rotor impact breaker	Crusher comprising one solid rotor equipped with replaceable blow bars.	 <p style="text-align: center;">Figure 95</p>
3.2.4.1.2	Double-rotor impact breaker	Crusher comprising two solid rotors turning in opposite directions and equipped with replaceable blow bars.	 <p style="text-align: center;">Figure 96</p>
3.2.4.2.	Swing-hammer crusher (hammer mill)	Crusher comprising one or two rotors to which hammers are attached by hinge pins.	See figures 97 and 98.

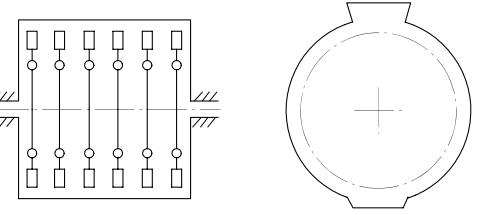
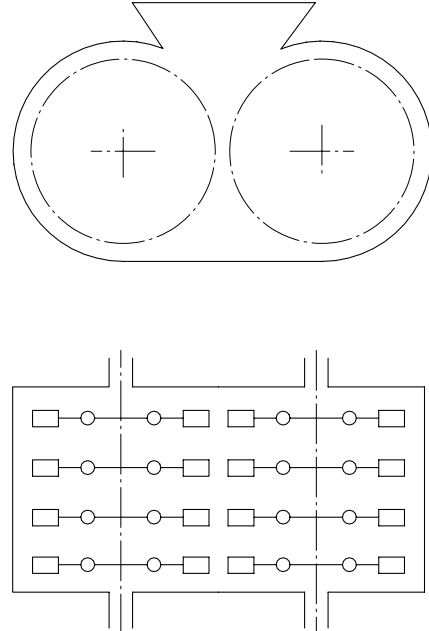
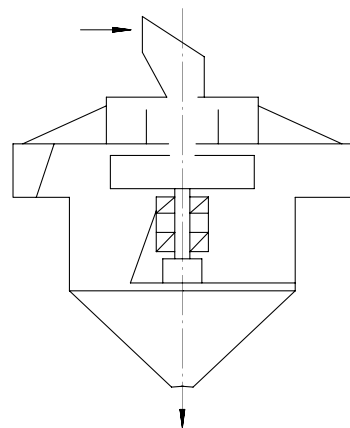
Item	Term	Definition	Illustration
3.2.4.2.1	Single-rotor swing-hammer crusher (hammer mill)	Crusher comprising one rotor to which hammers are attached by hinge pins.	 <p style="text-align: center;">Figure 97</p>
3.2.4.2.2	Double-rotor swing-hammer crusher (hammer mill)	Crusher comprising two rotors to which hammers are attached by hinge pins, turning in opposite directions.	 <p style="text-align: center;">Figure 98</p>
3.2.4.3	Vertical shaft impactor	Impact crusher consisting of a rotor or impeller disc mounted on a vertical shaft which is rotated at high speed, throwing materials against the anvils or previously crushed particles lining the crushing chamber or another part of fed material which bypasses the rotor.	 <p style="text-align: center;">Figure 99</p>

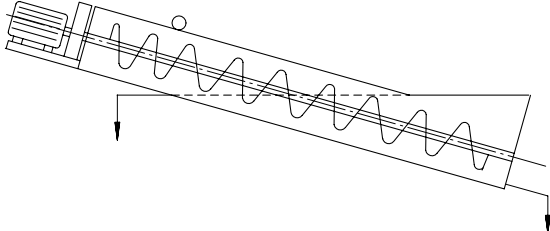
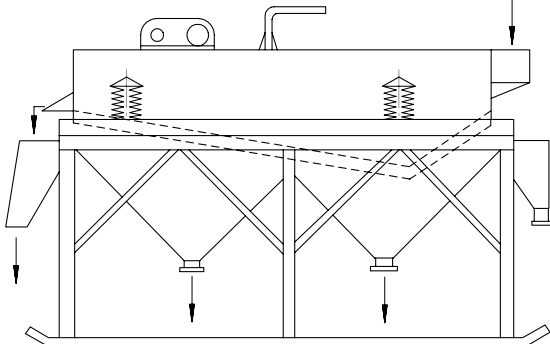
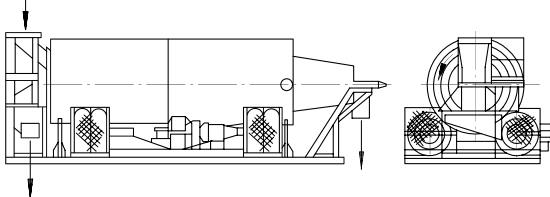
Item	Term	Definition	Illustration
3.3	Washing machine	Machine in which aggregate is cleaned from dust, loam and clay with the help of water.	See figures 100 to 102.
3.3.1	Log-washer	Water tank set at an angle and in which one or two shafts or logs rotate; the feed is introduced at the lower end and the paddles or worms subject it to a tumbling action; dirty water and fines are discharged at the lower end and washed aggregate at the upper end.	 <p style="text-align: center;">Figure 100</p>
3.3.2	Washing screen	Inclined vibratory screen providing tumbling action and transporting fed material either under water or under spray bars fixed above the screen decks.	 <p style="text-align: center;">Figure 101</p>
3.3.3	Barrel washer	Aggregate-washing device consisting of a rotating cylinder fitted internally with lifters which lift and move the aggregate along the barrel with (uniflow) or against (contraflow) the flow of the wash water.	 <p style="text-align: center;">Figure 102</p>

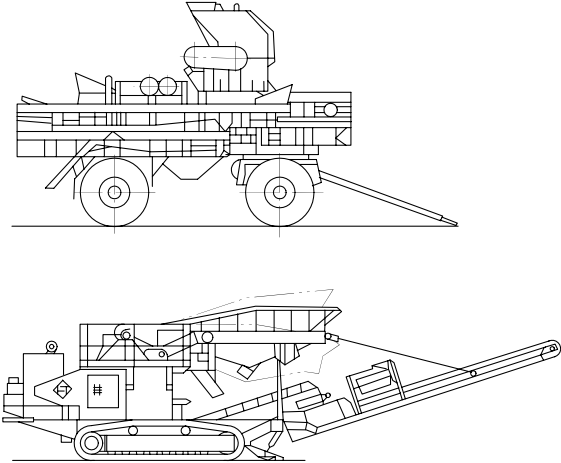
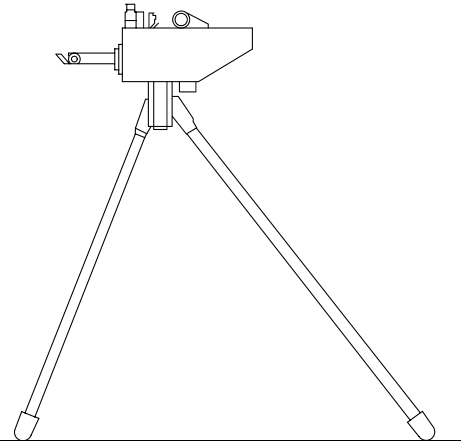
Item	Term	Definition	Illustration
3.4	Crushing and screening plant (recycling plant)	<p>Set of machines and devices for aggregate production (including solid wastes as a feed) mounted on either:</p> <p>a) trailer or semitrailer, or</p> <p>b) crawler.</p>	 <p style="text-align: center;">Figure 103</p>
4 Equipment for installation finishing work and maintenance			
4.1	Wallpaper preparation devices	Equipment for cutting wallpaper to length and spreading glue.	 <p style="text-align: center;">Figure 104</p>
4.2	Painting machines	Machines and equipment designed for on-site painting operations on building structures, and their elements, including surface preparation, mixing, straining, feeding and application of paints on coated surfaces.	See figures 105 to 114.

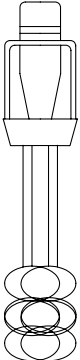
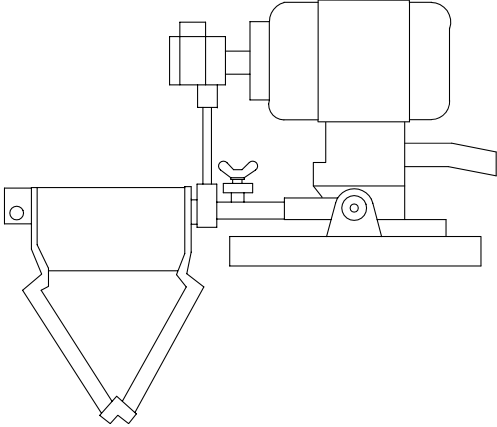
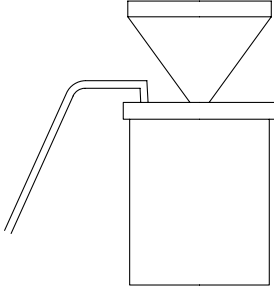
Item	Term	Definition	Illustration
4.2.1	Paint mixer	Machine for mixing paints to ensure their homogeneity.	 <p data-bbox="1187 647 1311 678">Figure 105</p>
4.2.2	Painter's strainer	Device for straining paints.	See figures 106 and 107.
4.2.2.1	Vibration screen	Painter's screen, vibrating to accelerate straining.	 <p data-bbox="1177 1272 1302 1303">Figure 106</p>
4.2.2.2	Vacuum screen	Painter's screen with a pressure reduction under the screen to speed up straining.	 <p data-bbox="1187 1641 1311 1673">Figure 107</p>
4.2.3	Painting unit	Machine designed for feeding and application of painting materials on coated surfaces. NOTE — Painting units consist of, at least, a paint delivering pump, delivery lines and spraying devices.	See figures 108 and 109.

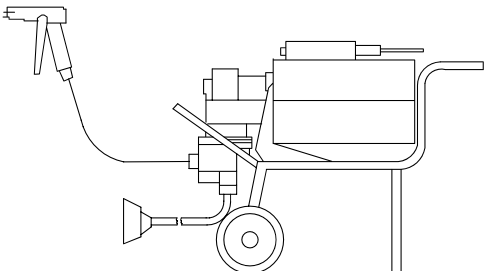
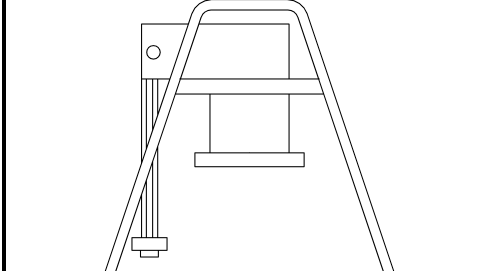
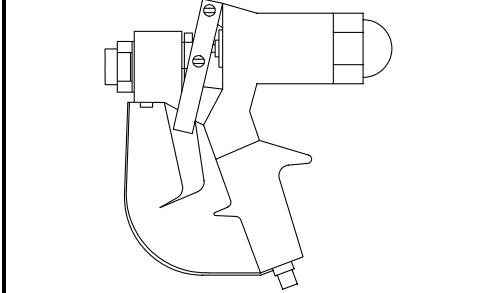
Item	Term	Definition	Illustration
4.2.3.1	Low-pressure painting units	Painting unit feeding paint to spraying devices at pressures not exceeding 0,2 MPa.	 <p style="text-align: center;">Figure 108</p>
4.2.3.2	High-pressure painting units	Painting units feeding paint to spraying devices at pressures in excess of 1,5 MPa.	 <p style="text-align: center;">Figure 109</p>
4.2.4	Spraying equipment	Equipment used for atomization and uniform spraying of paint.	See figure 110.
4.2.4.1	Pneumatic spraying equipment	Equipment fed with compressed air, causing paint atomization and distribution.	 <p style="text-align: center;">Figure 110</p>
4.2.4.1.1	Low-pressure pneumatic spraying equipment	Pneumatic spraying equipment requiring compressed air pressure in the range 0,001 MPa to 0,030 MPa.	See figure 110.
4.2.4.1.2	Medium-pressure pneumatic spraying equipment	Pneumatic spraying equipment requiring compressed air pressure above 0,100 MPa.	See figure 110.
4.2.4.2	Airless spraying gun	Spraying device in which paint atomization and distribution as spray is due to the pressure of the paint in the apparatus.	See figure 110.

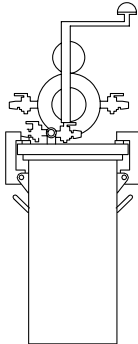
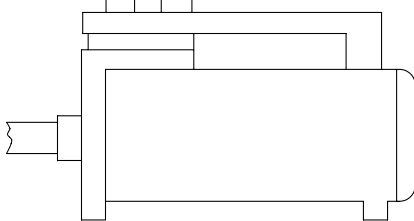
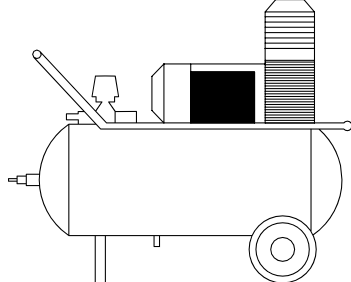
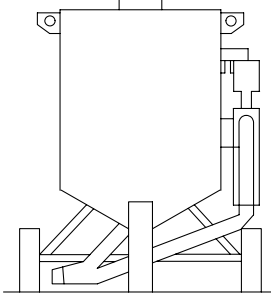
Item	Term	Definition	Illustration
4.2.5	Pressure vessel	Device used for feeding paint under pressure of compressed air through hoses to spraying apparatus.	 <p data-bbox="1187 629 1305 658">Figure 111</p>
4.2.6	Compressors and blowers	Machines designed for feeding compressed air to other machines and devices, including the equipment for finishing work.	See figures 112 and 113.
4.2.6.1	Blower	Machine for the compression and transmission of gaseous media and operating with a total pressure rise not exceeding 0,2 MPa. NOTE — Blowers used in finishing are applied for compressed air supply to low-pressure apparatus.	 <p data-bbox="1187 1037 1305 1066">Figure 112</p>
4.2.6.2	Compressor	Machine for the compression and transmission of gaseous media and operating with a total pressure increase exceeding 0,2 MPa.	 <p data-bbox="1187 1400 1305 1429">Figure 113</p>
4.2.7	Sand/grit blasting equipment	Equipment for surface preparation by sand blasting, before painting.	 <p data-bbox="1187 1780 1305 1809">Figure 114</p>
4.3	Machines for floor work	Machines designed for floor work on construction sites, including preparation, feeding and laying of the materials of subfloors, surface levelling and grinding, and trimming and joining of floor materials.	See figures 115 to 119.
4.3.1	Mortar feeders	Equipment designed to feed mortar for subfloors from ground level to the required level.	

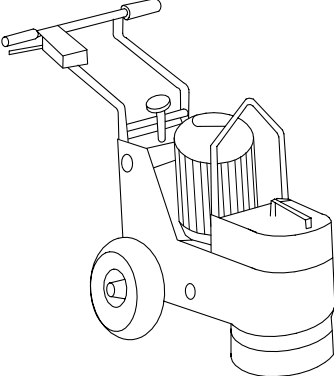
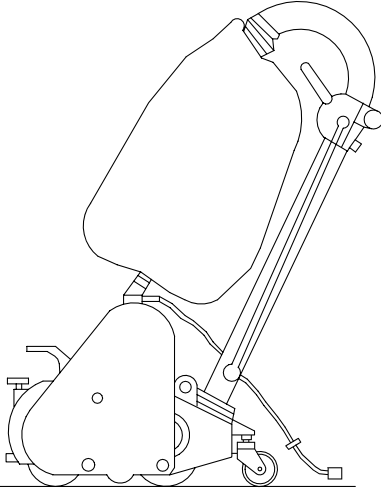
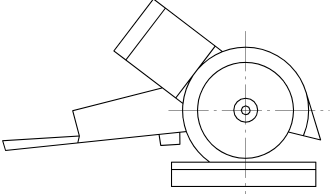
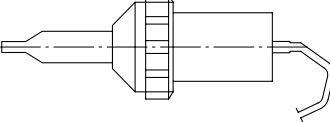
Item	Term	Definition	Illustration
4.3.2	Floor grinders	Machines for grinding floor surfaces.	See figures 115 to 119.
4.3.2.1	Mineral floor grinder	Grinder for floors made of natural or artificial mineral materials.	 <p data-bbox="1158 723 1278 748">Figure 115</p>
4.3.2.2	Wooden floor sander	Grinder for floors made of wood.	 <p data-bbox="1158 1294 1278 1319">Figure 116</p>
4.3.3	Floor tile cutter	Machine for cutting flooring tiles made of organic materials (plastics).	 <p data-bbox="1158 1576 1278 1601">Figure 117</p>
4.3.4	PVC flooring welder	Device for welding PVC flooring.	 <p data-bbox="1158 1787 1278 1812">Figure 118</p>

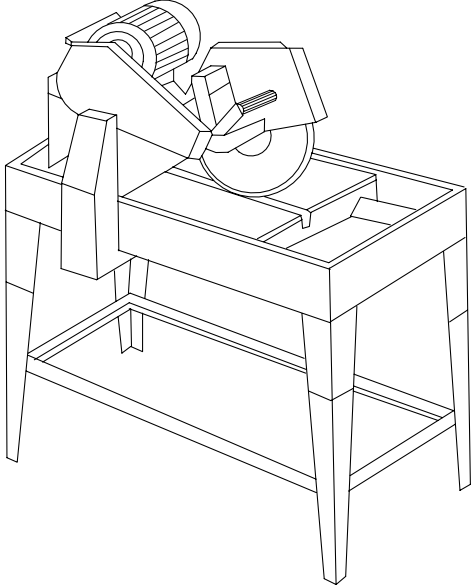
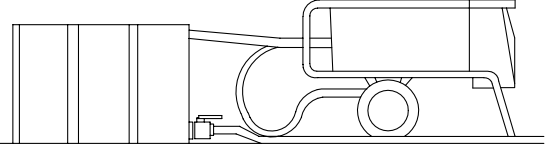
Item	Term	Definition	Illustration
4.3.5	Stone cutter	Machine for cutting natural and artificial building stones (materials of mineral origin).	 <p data-bbox="1187 943 1310 972">Figure 119</p>
4.4	Damp-proofing machines	Machines for application of waterproof insulation, including surface preparation, feeding and spraying of bitumen used without heating, for preparation, feeding and spraying of hot pitch, for bonding of roll materials, and for the jointing and application of plastic materials.	See figures 120 to 139.
4.4.1	Machine for cold application of bitumen	Machine for feeding and spraying liquid bitumen used without heating.	See figures 120 and 121.
4.4.1.1	Bituminous emulsion and dispersion sprayers	Machines for feeding and spraying bituminous emulsions and dispersions used in waterproofing (tanking).	 <p data-bbox="1150 1563 1273 1592">Figure 120</p>

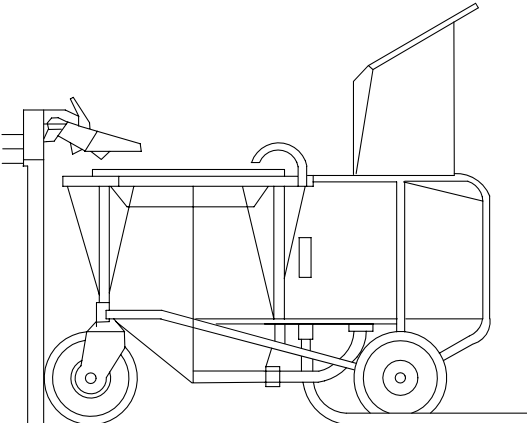
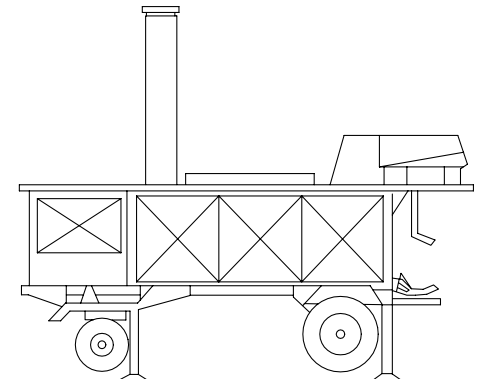
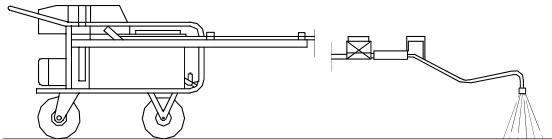
Item	Term	Definition	Illustration
4.4.1.2	Soluble bitumen sprayer	Machine for feeding and spraying of soluble bituminous compounds used in waterproofing.	 <p style="text-align: center;">Figure 121</p>
4.4.2	Hot pitch application equipment	Machine for pitch heating, feeding and spraying on insulated surfaces.	See figures 122 to 124.
4.4.2.1	Pitch boiler	<p>Equipment for heating pitch to the required temperature.</p> <p>NOTE — Boilers furnished with pumps and piping may feed hot pitch to elevations of several tens of metres.</p>	 <p style="text-align: center;">Figure 122</p>
4.4.2.2	Pitch sprayer	Device designed for spraying hot pitch onto insulated surfaces.	 <p style="text-align: center;">Figure 123</p>

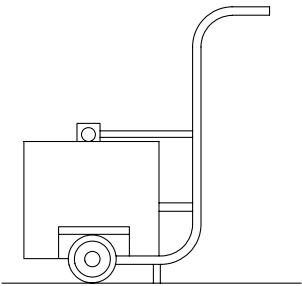
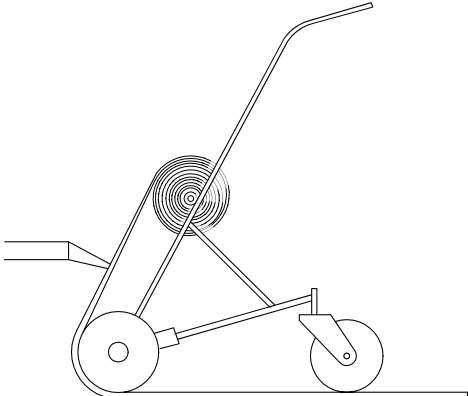
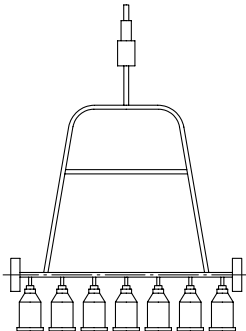
Item	Term	Definition	Illustration
4.4.2.3	Pitch container	Container for the storage and handling of hot pitch.	 <p data-bbox="1187 573 1311 600">Figure 124</p>
4.4.3	Machines for sticking roll materials to base	Machines designed for spreading adhesives on surfaces being dampproofed (with the exception of hot pitch), for heating of a pitch layer on tar paper, for unrolling of roll materials, and for pressing them against receiving surfaces.	See figures 125 to 128.
4.4.3.1	Tar paper unroller	Machine for unrolling, laying and sticking roll materials during bonding operation.	 <p data-bbox="1187 1236 1311 1263">Figure 125</p>
4.4.3.2	Gas burner	LPG burner designed for melting the excess pitch layer on tar paper, to make it stick to base.	 <p data-bbox="1187 1648 1311 1675">Figure 126</p>

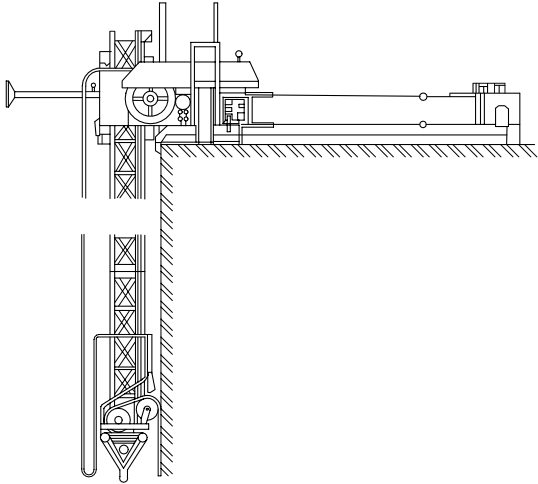
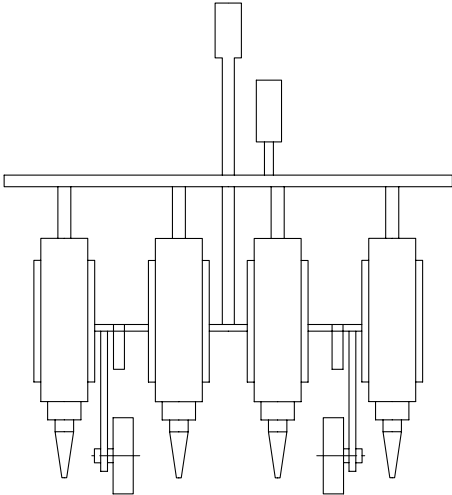
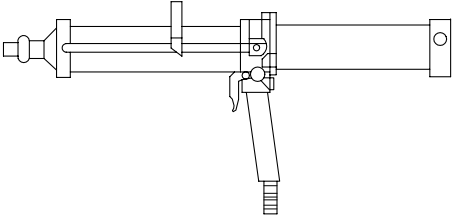
Item	Term	Definition	Illustration
4.4.3.3	Machine for vertical dampproofing	Machine designed for laying roll material insulation on vertical walls.	 <p style="text-align: center;">Figure 127</p>
4.4.3.4	Device for spreading adhesives	Device for spreading adhesives on surfaces to be coated with roll material or boards.	 <p style="text-align: center;">Figure 128</p>
4.4.4	Jointing device	Device designed for operations connected with filling gaps with special compounds (sealant).	See figures 129 and 130.
4.4.4.1	Jointing gun	Device for forcing putty out of containers through a nozzle in appropriate form for gap filling with the sealant.	 <p style="text-align: center;">Figure 129</p>

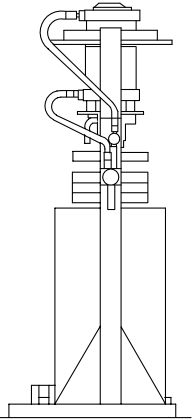
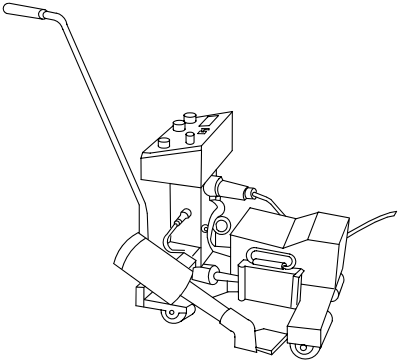
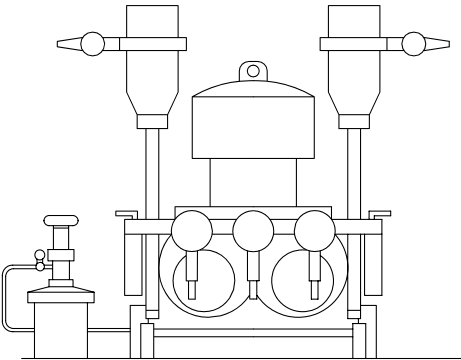
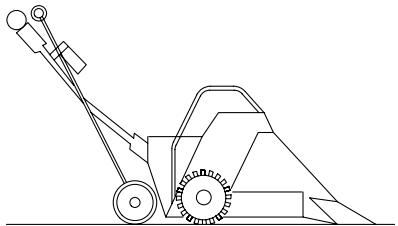
Item	Term	Definition	Illustration
4.4.4.2	Container-charging device	Device for charging the jointing gun containers with putty.	 <p data-bbox="1187 703 1315 734">Figure 130</p>
4.4.5	Equipment for application of insulating plastics	Appliance for laying plastic insulation, suitable for a variety of materials and their properties, e.g. for spraying liquid plastics or for welding plastic sheets.	See figures 131 and 132.
4.4.5.1	Plastic sheet welder	Appliance for welding sheet plastics.	 <p data-bbox="1187 1272 1315 1303">Figure 131</p>
4.4.5.2	Plastic insulation sprayer	<p data-bbox="491 1328 995 1384">Equipment for laying insulating layers by spraying plastics.</p> <p data-bbox="491 1391 995 1469">NOTE — This group includes two-component sprayers with mixing of the components either at the nozzle outlet or in the spraying gun.</p>	 <p data-bbox="1187 1709 1315 1740">Figure 132</p>
4.4.6	Machine for stripping insulation	Machine designed for stripping old insulation off its base, in preparation for laying a new one.	 <p data-bbox="1187 2011 1315 2042">Figure 133</p>

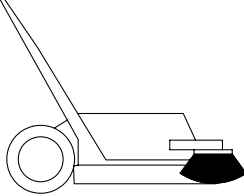
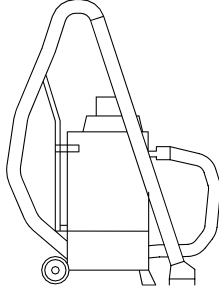
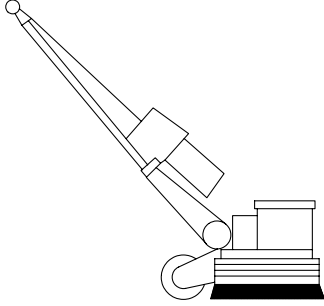
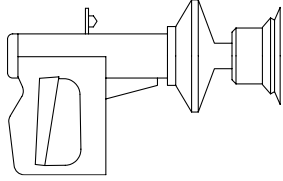
Item	Term	Definition	Illustration
4.5	Clean-up equipment	Equipment designed for clean-up operations on site during building construction, including sweeping, vacuum cleaning, washing and maintenance of floors and stairs.	See figures 134 to 136.
4.5.1	Sweeper	Appliance for sweeping solid pieces and dirt accompanying construction work.	 <p data-bbox="1157 618 1283 645">Figure 134</p>
4.5.2	Vacuum cleaner	Suction device for the collection of solid debris and dust.	 <p data-bbox="1157 987 1283 1014">Figure 135</p>
4.5.3	Brusher	Machine for the removal by brushing of dirt sticking to surfaces.	 <p data-bbox="1157 1368 1283 1395">Figure 136</p>
4.5.4	Floor polisher	Machine for floor polish spreading and polishing.	See figure 136.
4.6	Fixing tools	Tools for minor fixing and attaching operations during construction. NOTE — This group comprises only the fixing tools used on construction sites.	See figures 137 to 139.
4.6.1	Cartridge-charged fixing tool	Tool designed for embedding nails, pins and studs in solids by explosive cartridges.	 <p data-bbox="1157 1832 1283 1859">Figure 137</p>

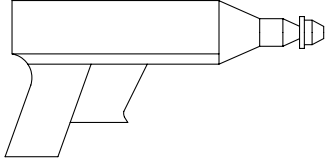
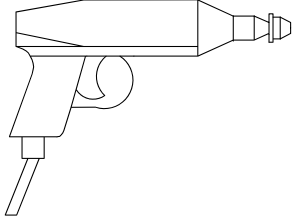
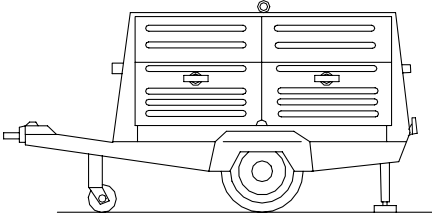
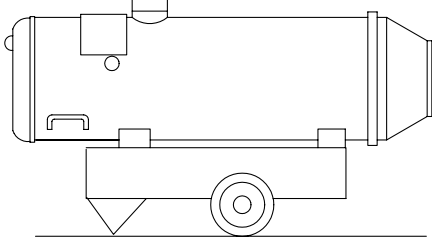
Item	Term	Definition	Illustration
4.6.2	Bonding tool	Tool for joining structural elements with adhesives, including plastic adhesives that require heating.	 <p data-bbox="1187 450 1313 477">Figure 138</p>
4.6.3	Drilling and screwing tool	Tool used to apply fasteners during construction, associated with drilling and/or screwing and usually equipped with electric or pneumatic drive.	 <p data-bbox="1187 748 1313 775">Figure 139</p>
5 General-use machinery and equipment used in construction processes			
5.1	Machines and equipment for the generation, conversion and transmission of energy	Machines and equipment used on site during construction and accompanying work, designed for generation, conversion and transmission of energy.	See figures 140 and 141.
5.1.1	Electric power machines	Machines and equipment for the generation, conversion and transmission of electric power.	 <p data-bbox="1187 1263 1313 1290">Figure 140</p>
5.1.2	Thermal energy machines	Machines and equipment for the generation, conversion and transmission of thermal energy.	 <p data-bbox="1187 1588 1313 1615">Figure 141</p>
5.1.3	Compressed air machines	Machines and equipment for the generation, conversion and transmission of compressed air. NOTE — A detailed specification of compressors may be found in ISO 5390:1977, <i>Compressors — Classification</i> .	

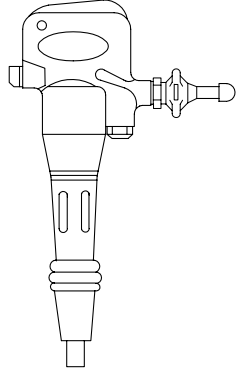
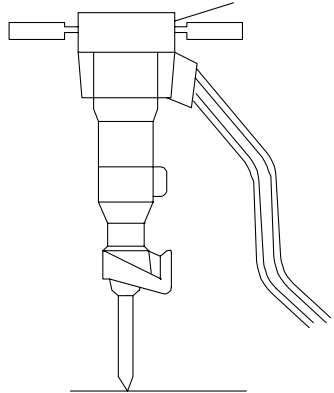
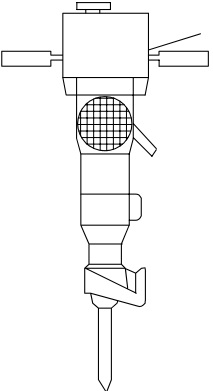
Item	Term	Definition	Illustration
5.2	Electric, pneumatic, hydraulic and other hand-guided hammers	<p>Hammers with electric, pneumatic, hydraulic and other (e.g. mechanical) drive, used on construction sites and driven either by power units integral with building construction machinery, or by independent power units.</p> <p>NOTE — The tools considered in 5.2 may either be mounted on building construction machinery but guided by hand, or operated independently but driven from such equipment.</p>	See figures 140 to 144.
5.2.1	Portable electric hammer	Electrically driven tool, used on construction sites.	See figure 139.
5.2.2	Portable pneumatic hammer	Pneumatically driven tool, used on construction sites.	 <p style="text-align: center;">Figure 142</p>
5.2.3	Portable hydraulic hammer	Hydraulically driven tool, used on construction sites.	 <p style="text-align: center;">Figure 143</p>
5.2.4	Petrol-driven hammer	Petrol-driven hammer, used on construction sites.	 <p style="text-align: center;">Figure 144</p>

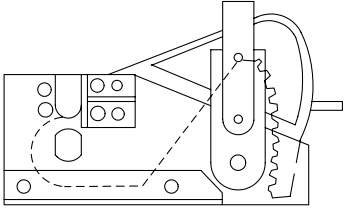
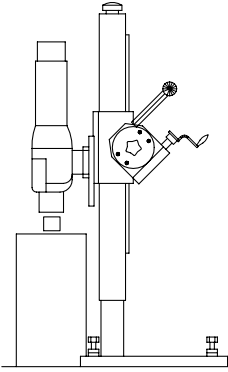
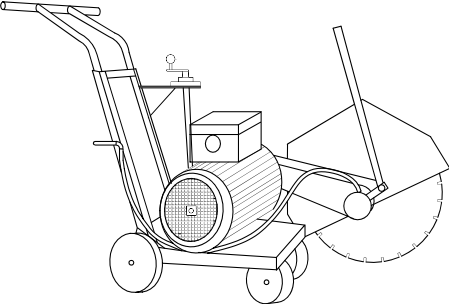
Item	Term	Definition	Illustration
5.2.5	Other tools	Tools with other drives (e.g. hand-operated), used on construction sites.	 <p style="text-align: center;">Figure 145</p>
5.3	Drills, saws, brusters and crushers	Machines incorporating diamond cutting tools for drilling and sawing concrete structures, asphalt and other construction materials; also equipment for the controlled demolition of structures using bursting and crushing techniques.	See figures 146 to 149.
5.3.1	Core drill	<p>Portable and trailer-mounted drilling rig using diamond-tipped drill bits and a water supply, for drilling holes into concrete and other structures.</p> <p>NOTE — They may have manual or powered feed.</p>	 <p style="text-align: center;">Figure 146</p>
5.3.2	Floor saw	Pedestrian-operated, trailer-mounted and self-propelled sawing machine using diamond-tipped blades for cutting and grooves slabs, floors and similar.	 <p style="text-align: center;">Figure 147</p>

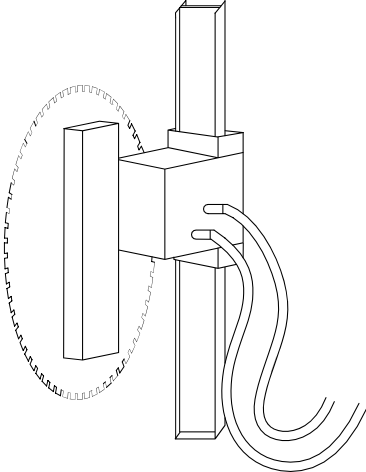
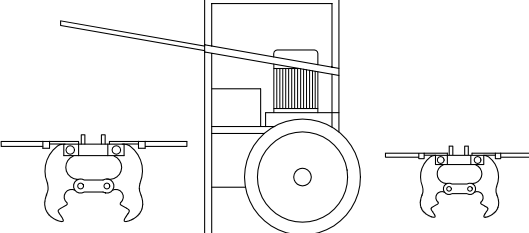
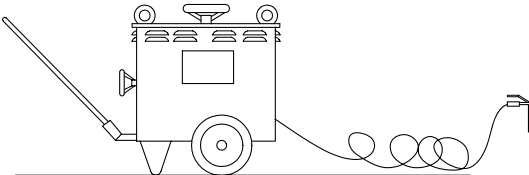
Item	Term	Definition	Illustration
5.3.3	Wall- or rail-mounted saw	Rail-mounted machine for cutting sections from concrete structures using diamond-tipped blades.	 <p style="text-align: center;">Figure 148</p>
5.3.4	Burster	Hydraulic equipment for the bursting of concrete sections using expanding plugs.	
5.3.5	Crusher	Portable hydraulic crushing device for crushing and breaking off a section from a concrete structure.	 <p style="text-align: center;">Figure 149</p>
5.4	Welding and other jointing equipment	Equipment for welding and for other methods of permanent jointing, used on construction sites and employing either machine-mounted or independent power sources.	See figures 150 and 151.
5.4.1	Welding equipment	Equipment on construction sites, used for joining materials by arc and oxyacetylene welding.	 <p style="text-align: center;">Figure 150</p>

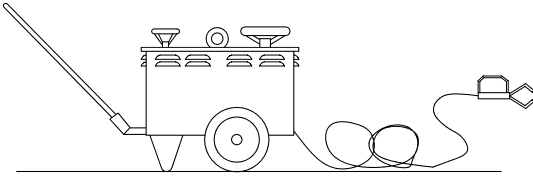
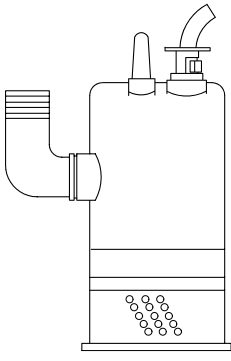
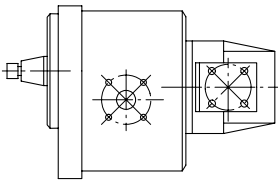
Item	Term	Definition	Illustration
5.4.2	Resistance welding equipment	Equipment on construction sites, used for joining materials by spot and other resistance welding.	 <p style="text-align: center;">Figure 151</p>
5.4.3	Other jointing equipment	Equipment on construction sites, used for joining materials by methods other than welding (e.g. by gluing).	See figure 138.
5.5	Pumps and accessories	Machines and equipment for the conversion of other forms of energy into the hydraulic energy. NOTE — Pumps may employ either their own or independent power sources.	See figures 152 to 154.
5.5.1	Pumps		See figures 152 and 153.
5.5.1.1	Rotodynamic pump	Pump using an impeller or a rotor furnished with blades as the active component producing the increase of hydraulic energy.	 <p style="text-align: center;">Figure 152</p>
5.5.1.2	Positive-displacement pump	Pump where the motion of an active component forces a portion of fluid to pass from the suction to the delivery side, with the work of the active component being converted directly into pressure energy.	 <p style="text-align: center;">Figure 153</p>

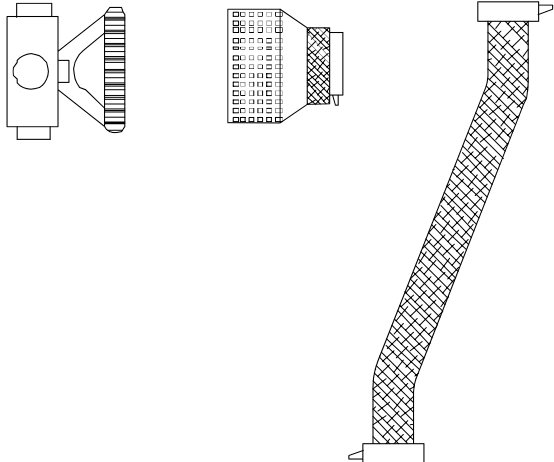
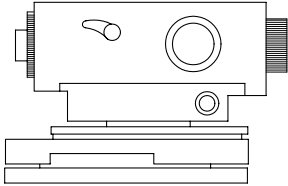
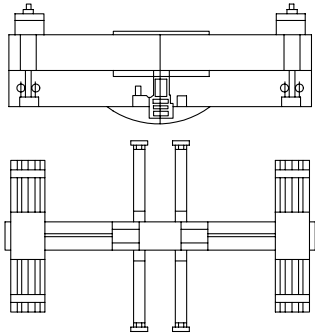
Item	Term	Definition	Illustration
5.5.2	Pump accessory equipment	Valves, hoses and equipment for distribution of fluid delivered by, and returned to, a pump.	 <p style="text-align: center;">Figure 154</p>
5.6	Measuring and inspection equipment	Equipment used on a building construction site prior, in course of, and after, completion of construction work, in order to: <ul style="list-style-type: none"> — determine the conditions at the start of construction work; — monitor the progress of work; — determine if the final outcome of the construction work is in compliance with assumptions and requirements. NOTE — Specific terminology of the measuring and inspection equipment agree with the recommendations of the <i>Organisation Internationale de Métrologie Légale, Termes fondamentaux (1969)</i> .	Without illustration
5.6.1	Measuring and inspection equipment used on site in the course of construction work	Equipment used on a construction site for carrying out checks while construction work is in progress, or for preparation of the subsequent stages of construction work.	 <p style="text-align: center;">Figure 155</p>
5.6.2	Measuring and inspection equipment used on site after completion of construction work	Equipment used after completion of construction work for final checks and inspection.	 <p style="text-align: center;">Figure 156</p>

ICS 01.040.91;91.220

Descriptors: building sites, machinery, equipment, site equipment, definitions, nomenclature, vocabulary.

Price based on 54 pages
