Adhesives — T-peel test for flexible-to-flexible bonded assemblies

Adhésifs — Essai de pelage en T d'assemblages collés flexible sur flexible



Reference number
ISO 11339:2010(E)

© ISO 2010

PDF disclaimer

This PDF file may contain embedded typefaces. In accordance with Adobe's licensing policy, this file may be printed or viewed but shall not be edited unless the typefaces which are embedded are licensed to and installed on the computer performing the editing. In downloading this file, parties accept therein the responsibility of not infringing Adobe's licensing policy. The ISO Central Secretariat accepts no liability in this area.

Adobe is a trademark of Adobe Systems Incorporated.

Details of the software products used to create this PDF file can be found in the General Info relative to the file; the PDF-creation parameters were optimized for printing. Every care has been taken to ensure that the file is suitable for use by ISO member bodies. In the unlikely event that a problem relating to it is found, please inform the Central Secretariat at the address given below.



COPYRIGHT PROTECTED DOCUMENT

© ISO 2010

All rights reserved. Unless otherwise specified, no part of this publication may be reproduced or utilized in any form or by any means, electronic or mechanical, including photocopying and microfilm, without permission in writing from either ISO at the address below or ISO's member body in the country of the requester.

ISO copyright office
Case postale 56 • CH-1211 Geneva 20
Tel. + 41 22 749 01 11
Fax + 41 22 749 09 47
E-mail copyright@iso.org
Web www.iso.org

Published in Switzerland

Contents

Page

Foreword	iv
1 Scope	1
2 Normative references	1
3 Terms and definitions	1
4 Principle	2
5 Apparatus	2
6 Test specimens	2
7 Procedure	3
8 Expression of results	4
9 Precision	4
10 Test report	5
Bibliography	6

Foreword

ISO (the International Organization for Standardization) is a worldwide federation of national standards bodies (ISO member bodies). The work of preparing International Standards is normally carried out through ISO technical committees. Each member body interested in a subject for which a technical committee has been established has the right to be represented on that committee. International organizations, governmental and non-governmental, in liaison with ISO, also take part in the work. ISO collaborates closely with the International Electrotechnical Commission (IEC) on all matters of electrotechnical standardization.

International Standards are drafted in accordance with the rules given in the ISO/IEC Directives, Part 2.

The main task of technical committees is to prepare International Standards. Draft International Standards adopted by the technical committees are circulated to the member bodies for voting. Publication as an International Standard requires approval by at least 75 % of the member bodies casting a vote.

Attention is drawn to the possibility that some of the elements of this document may be the subject of patent rights. ISO shall not be held responsible for identifying any or all such patent rights.

ISO 11339 was prepared by Technical Committee ISO/TC 61, *Plastics*, Subcommittee SC 11, *Products*.

This third edition cancels and replaces the second edition (ISO 11339:2003), of which it constitutes a minor revision. The main changes are as follows:

- a) the normative references have been updated;
- b) explanatory footnotes have been added to Subclause 6.3;
- c) the peel strength values calculated are reported in newtons per 100 mm of specimen width (as opposed to kilonewtons per metre in the previous edition).

In addition, a number of editorial changes have been made to improve the clarity of the text.

Adhesives — T-peel test for flexible-to-flexible bonded assemblies

SAFETY STATEMENT — Persons using this document should be familiar with normal laboratory practice, if applicable. This document does not purport to address all of the safety problems, if any, associated with its use. It is the responsibility of the user to establish appropriate safety and health practices and to ensure compliance with any regulatory conditions.

It is recognized that some of the materials permitted in this document may have a negative environmental impact. As technological advances lead to more acceptable alternatives for such materials, they will be eliminated to the greatest extent possible.

At the end of the test, care should be taken to dispose of all waste in an appropriate manner in accordance with local regulations.

1 Scope

This International Standard specifies a T-peel test for the determination of the peel strength of an adhesive by measuring the peeling force of a T-shaped bonded assembly of two flexible adherends. This test procedure does not provide design information.

NOTE This method was originally developed for use with metal adherends but other, flexible, adherends may also be used.

2 Normative references

The following referenced documents are indispensable for the application of this document. For dated references, only the edition cited applies. For undated references, the latest edition of the referenced document (including any amendments) applies.

ISO 291, *Plastics — Standard atmospheres for conditioning and testing*

ISO 10365, *Adhesives — Designation of main failure patterns*

ISO 17212, *Structural adhesives — Guidelines for the surface preparation of metals and plastics prior to adhesive bonding*

3 Terms and definitions

For the purposes of this document, the following terms and definitions apply.

3.1

peel strength

force per unit width necessary to bring an adhesive joint to the point of failure and/or maintain a specified rate of failure by means of a stress applied in a peeling mode

[ISO 472:1999]

3.2 flexible adherend
adherend having dimensions and physical properties that permit bending through any angle up to 90° without breaking or cracking

4 Principle

For the T-peel test for a flexible-to-flexible assembly, the force is applied to the unbonded ends of the specimen. The angle between the bond line and the direction of the applied force is not fixed.

Adherends are separated at an approximately steady rate from an open edge of a prepared bond so that separation occurs progressively along the bond line.

5 Apparatus

5.1 Tensile-testing machine¹⁾, capable of maintaining a predetermined constant crosshead rate (preferred rate 100 mm/min). It shall be provided with a suitable self-aligning grip to hold the specimen. Each set of jaws of the grip shall firmly engage the outer 25 mm of the unbonded ends of the flexible adherends. The grip and attachments shall be constructed in such a way that they will move into alignment with the specimen as soon as the force is applied. The machine shall produce a chart that can be read in terms of millimetres of crosshead movement as a function of the applied force.

The machine shall permit the measurement and recording of the applied force with an accuracy of $\pm 2\%$. All equipment shall be calibrated regularly. It is recommended that a clamping device with low inertia be used.

5.2 Device for measuring thickness, with an accuracy of $\pm 0,01$ mm, or a means of checking the thickness to that tolerance.

6 Test specimens

6.1 Test specimens of the dimensions shown in Figure 1 shall be prepared, either individually or cut from bonded laminates. Test specimens shall consist of two flexible adherends properly prepared and bonded together.

6.2 Surface treatment shall be such as to obtain optimum strength in the bonded assembly. The preparation of the surface shall be in accordance with ISO 17212, and details of the preparation shall be stated in the test report.

The adhesive shall be applied in accordance with the manufacturer's instructions to obtain an optimum bond with minimum variation; the procedure used shall be reported in the test report.

NOTE Direct comparison of different adhesives can be made only when specimen construction, adherend materials and dimensions, and test conditions are identical.

6.3 The thickness of the flexible adherends shall be reported.

The preferred thicknesses are 0,5 mm \pm 0,02 mm for steel (type XES)²⁾ and 0,7 mm \pm 0,02 mm or 0,5 mm \pm 0,02 mm for aluminium (type 5754, H111)³⁾ unless otherwise specified.

1) See for instance ISO 5893^[4].

2) XES = low-carbon steel: composition (in mass %) C = 0,05, Cr < 0,01, Cu = 0,013, Mn = 0,018, Al = 0,064, Ni = 0,02; Young's modulus $E = 210$ GPa; initial yield stress $\sigma_y = 150$ MPa; strain-hardening coefficient $n = 0,4$.

3) See ISO 209^[1] and ISO 2107^[3].

6.4 Test specimens shall be cut from the bonded panels (see Figure 1) by a method that is not deleterious to the bond.

The width shall be either

a) 25 mm (preferred width)

or

b) any other convenient width, provided that the test equipment is suitably adapted and the width is stated in the test report.

NOTE The method of cutting the specimens is dependent upon the adherend and adhesive compositions and the specimen width tolerance specified in Figure 1. Milling and bandsawing are two methods commonly used for this purpose.

6.5 Before the test is carried out, the test specimen shall be bent in a manner that does not affect the bonded joint. The two unbonded ends of the flexible adherends shall be bent in opposite directions until each end is perpendicular to the bonded assembly, to form a T-shaped specimen (see Figure 1) for clamping in the grips of the test machine.

6.6 The number of specimens tested shall be not less than five.

6.7 The specimens shall be conditioned and tested in one of the standard laboratory atmospheres specified in ISO 291, which shall be reported in the test report.

7 Procedure

On the at least five specimens, using the device described in 5.2, measure with an accuracy of $\pm 0,01$ mm the average thickness of the adhesive layer after formation of the bond. Clamp each unbonded end of the T-shaped specimen in the grips of the test machine, taking care that the end is accurately aligned between the grips so that the tension applied is distributed evenly across the width. If one adherend is more flexible than the other, attach the less flexible adherend to the moveable grip.

Set the machine in motion at the selected separation rate and record the force applied versus the distance of grip separation.

NOTE A separation rate of 100 mm/min is generally used for metals and 10 mm/min for other adherends.

Continue the test until at least 150 mm of the bonded length is separated. Note the type of failure in accordance with ISO 10365.

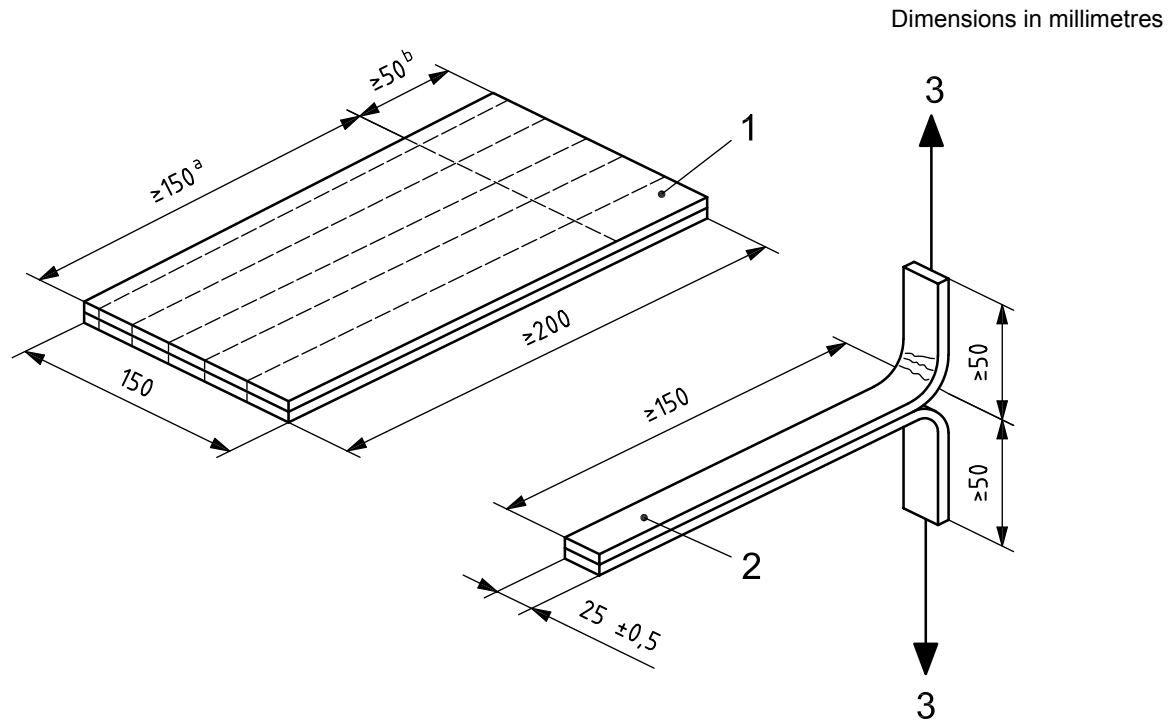

Key

- 1 specimen cut at panel edge
 - 2 specimen
 - 3 direction of pull
- a Bonded.
b Unbonded.

Figure 1 — Panel before cutting and individual specimen after cutting

8 Expression of results

Determine from the recorded curve, for about 100 mm of peeling (disregarding the first 25 mm and the last 25 mm), the average, maximum and minimum peeling force, in newtons, required to separate the adherends. The average force shall be determined from the curve by drawing the best straight line, or by using other suitable means if a more accurate result is required.

Record the average, maximum and minimum peeling forces for each individual specimen.

From the peeling forces thus recorded, calculate the average, maximum and minimum peel strengths for each individual specimen, in newtons per 100 mm of specimen width.

9 Precision

The precision of this test method is not known because interlaboratory data are not available. When interlaboratory data are obtained, a precision statement will be added at the following revision.

10 Test report

The test report shall include the following information:

- a) a reference to this International Standard;
- b) all information necessary for complete identification of the adhesive tested, including type, source, manufacturer's code number, batch or lot number, form, etc.;
- c) all information necessary for complete identification of the adherends, including the nature and the thickness of the material, the width and the surface preparation;
- d) a description of the bonding process, including the method of application of the adhesive, the drying or curing conditions (where applicable) and the curing time, temperature and pressure;
- e) the average thickness of the adhesive layer after formation of the bond;
- f) a complete description of the specimen, whether individual or cut from a panel, including the dimensions and construction of the specimen, the conditions used for cutting out individual specimens, the number of test panels represented and the number of individual specimens (when edge specimens are tested, they shall be designated "edge specimens");
- g) the conditioning procedure used prior to testing and the test atmosphere;
- h) the crosshead separation rate;
- i) the method for determining the average peeling force;
- j) the average, maximum and minimum peeling force values, in newtons, for each individual specimen (edge specimens shall be reported separately);
- k) the calculated average, maximum and minimum peel strength values, in newtons per 100 mm of specimen width, for each specimen (edge specimens shall be reported separately);
- l) the type of failure in accordance with ISO 10365.

Bibliography

- [1] ISO 209, *Aluminium and aluminium alloys — Chemical composition*
- [2] ISO 472:1999, *Plastics — Vocabulary*
- [3] ISO 2107, *Aluminium and aluminium alloys — Wrought products — Temper designations*
- [4] ISO 5893, *Rubber and plastics test equipment — Tensile, flexural and compression types (constant rate of traverse) — Specification*

1

.....

ICS 83.180

Price based on 6 pages