**Soil quality — Determination of total
cyanide**

Qualité du sol — Dosage des cyanures totaux



Reference number
ISO 11262:2011(E)

© ISO 2011



COPYRIGHT PROTECTED DOCUMENT

© ISO 2011

All rights reserved. Unless otherwise specified, no part of this publication may be reproduced or utilized in any form or by any means, electronic or mechanical, including photocopying and microfilm, without permission in writing from either ISO at the address below or ISO's member body in the country of the requester.

ISO copyright office
Case postale 56 • CH-1211 Geneva 20
Tel. + 41 22 749 01 11
Fax + 41 22 749 09 47
E-mail copyright@iso.org
Web www.iso.org

Published in Switzerland

Contents

Page

Foreword	iv
Introduction	v
1 Scope	1
2 Normative references	1
3 Terms and definitions	1
4 Principle	2
4.1 Direct liberation of hydrogen cyanide using orthophosphoric acid	2
4.2 Determination of total cyanide content	2
5 Reagents	2
5.1 Reagents for liberation and absorption of cyanide	2
5.2 Reagents for the photometric determination of cyanide	3
5.3 Reagents for the titrimetric determination of cyanide	3
6 Apparatus	4
7 Sample preservation and preparation	5
7.1 Sample preservation	5
7.2 Sample preparation	5
8 Direct liberation using orthophosphoric acid	6
8.1 Procedure	6
8.2 Blank test	6
9 Determination of cyanide — Photometric method	7
9.1 Applicability	7
9.2 Procedure	7
9.3 Preparation of the calibration graph	7
9.4 Calculation	7
10 Determination of cyanide — Titrimetric method using an indicator	8
10.1 Applicability	8
10.2 Procedure	8
10.3 Calculation	9
11 Expression of results	9
12 Precision	10
13 Test report	10
Annex A (informative) Precision data	11
Annex B (informative) Extraction with sodium hydroxide solution and subsequent liberation using orthophosphoric acid	12
Annex C (informative) Comparison of the direct liberation of total cyanide and sodium hydroxide extraction with subsequent liberation	15
Bibliography	16

Foreword

ISO (the International Organization for Standardization) is a worldwide federation of national standards bodies (ISO member bodies). The work of preparing International Standards is normally carried out through ISO technical committees. Each member body interested in a subject for which a technical committee has been established has the right to be represented on that committee. International organizations, governmental and non-governmental, in liaison with ISO, also take part in the work. ISO collaborates closely with the International Electrotechnical Commission (IEC) on all matters of electrotechnical standardization.

International Standards are drafted in accordance with the rules given in the ISO/IEC Directives, Part 2.

The main task of technical committees is to prepare International Standards. Draft International Standards adopted by the technical committees are circulated to the member bodies for voting. Publication as an International Standard requires approval by at least 75 % of the member bodies casting a vote.

Attention is drawn to the possibility that some of the elements of this document may be the subject of patent rights. ISO shall not be held responsible for identifying any or all such patent rights.

ISO 11262 was prepared by Technical Committee ISO/TC 190, *Soil quality*, Subcommittee SC 3, *Chemical methods and soil characteristics*.

This second edition cancels and replaces the first edition (ISO 11262:2003), which has been technically revised. This edition specifies two methods for the determination of the total cyanide content. It is only validated for direct liberation using orthophosphoric acid, Annex A provides new validation data. A method with an alkaline extraction before liberation is described in Annex B. In addition, the text has been editorially revised.

Introduction

Cyanides form simple salts with alkali earth cations and ionic complexes of varying strengths with numerous metal cations; the stability of these compounds is dependent on the cation and on the pH. Cyanide forms complexes with gold, mercury, cobalt and iron that are very stable even under mildly acidic conditions. Metal cyanide complexes also form salt-type compounds with alkali or heavy-metal cations, such as potassium ferrocyanide ($K_4[Fe(CN)_6]$) or copper ferrocyanide ($Cu_2[Fe(CN)_6]$). Cyanides can be present in soil both as cyanide ions and as complex cyanides.

Determination of cyanides can be carried out under different conditions. When using mild acidic conditions (e.g. pH = 4), only so-called “easily liberatable cyanides” (also known as “weak-acid dissociable cyanides”) are measured. Under strong acidic conditions (e.g. pH = 1), all cyanides (both easily liberatable and complex cyanides) can be determined, these are called “total cyanides”.

A number of studies in soil samples have demonstrated that it is impossible to obtain reliable results for easily liberatable cyanide (ELC) using a manual ELC cyanide extraction/reflux method. Consequently, this revised International Standard does not include an ELC method.

NOTE ISO 17380 gives details of both an automated ELC method and a total cyanide method.

This International Standard specifies manual methods for the determination of total cyanide only. An alternative method for alkaline extraction prior to liberation using orthophosphoric acid is described in Annex B.

© ISO 2011. All rights reserved.

www.iso.org

Soil quality — Determination of total cyanide

WARNING — Hydrogen cyanide and its salts are toxic. Therefore, care shall be exercised when manipulating cyanide-contaminated samples. Volatile hydrogen cyanide (with a smell of bitter almonds) is released from acidified solutions containing cyanide salts. As a minimum, all work shall be carried out in a fume hood and suitable plastic gloves shall be worn when handling contaminated samples.

Analytical wastes containing cyanides shall be placed in a special container with a lid, in the laboratory, for temporary storage. This container shall be clearly marked with labels such as “toxic waste” or “cyanides”. Periodically, the container shall be emptied and the wastes containing cyanides disposed of as “special waste” by an appropriate waste-management contractor.

1 Scope

This International Standard is applicable to as-received (field-moist) samples and specifies two different procedures for the liberation of cyanide from the soil:

- direct liberation of hydrogen cyanide using orthophosphoric acid (normative);
- extraction with sodium hydroxide solution and subsequent liberation using orthophosphoric acid (informative, see Annex B).

The liberated cyanide is determined either by a photometric method or a titrimetric method using an indicator.

The method is applicable to all types of soil.

Under the conditions specified in this International Standard, the lower limit of application is 0,5 mg/kg of total cyanide (expressed on the as-received basis) for photometric determination and 10 mg/kg for titrimetric determination.

NOTE Using the alkaline extraction followed by liberation using phosphoric acid, the lower limit of application is 1 mg/kg of total cyanide (expressed on the as-received basis) for photometric determination and 30 mg/kg for titrimetric determination.

2 Normative references

The following referenced documents are indispensable for the application of this document. For dated references, only the edition cited applies. For undated references, the latest edition of the referenced document (including any amendments) applies.

ISO 3696:1987, *Water for analytical laboratory use — Specification and test methods*

ISO 9297, *Water quality — Determination of chloride — Silver nitrate titration with chromate indicator (Mohr's method)*

ISO 11464, *Soil quality — Pretreatment of samples for physico-chemical analysis*

ISO 11465, *Soil quality — Determination of dry matter and water content on a mass basis — Gravimetric method*

ISO 14507, *Soil quality — Pretreatment of samples for determination of organic contaminants*

3 Terms and definitions

For the purposes of this document, the following terms and definitions apply.

3.1

total cyanide

all compounds which form hydrogen cyanide under the conditions of this method

3.2

recovery factor

F_{RC}

recovery factor (F_{RC}) of the liberation apparatus for total cyanide is the fractional recovery of a mid-range standard containing potassium hexacyanoferrate(III) carried through the whole procedure against an equivalent calibration standard of potassium cyanide not carried through the liberation stage, but only through the final detection stage of the method (m_{found}/m_{known})

4 Principle

4.1 Direct liberation of hydrogen cyanide using orthophosphoric acid

The field-moist sample is homogenized and pretreated in accordance with ISO 14507, removing visible coarse constituents. It is then treated with orthophosphoric acid and the liberated hydrogen cyanide is transported by an airflow and absorbed into 1 mol/l sodium hydroxide. Tin(II) and copper(II) salts are added to suppress the interference from sulfur compounds and catalyse the decomposition of complex cyanides during the liberation process.

4.2 Determination of total cyanide content

Cyanide ion in the sodium hydroxide absorber solutions is determined either

- photometrically (see Clause 9) by a procedure based on the reaction of cyanide with chloramine-T with the formation of cyanogen chloride; this reacts with pyridine-4-carboxylic acid and 1,3-dimethylbarbituric acid to form a coloured complex, the absorbance of which is measured at 606 nm, or
- titrimetrically (see Clause 10) by a titrimetric procedure involving titration with silver nitrate. When in excess relative to the $Ag(CN)_2^-$ ion, silver ions form a red-coloured complex with the end-point indicator, 5-(4-dimethylaminobenzylidene)rhodanine.

5 Reagents

All reagents shall be of recognized analytical grade and the water used shall conform to grade 2 of ISO 3696:1987. All reagents are stable for at least 3 months unless stated otherwise.

5.1 Reagents for liberation and absorption of cyanide

5.1.1 Orthophosphoric acid, $w(H_3PO_4) = 85\%$ (mass fraction), $\rho = 1,69$ g/ml.

5.1.2 Sodium hydroxide solution, $c(NaOH) = 1$ mol/l.

Dissolve 40 g of NaOH in water and dilute with water to 1 000 ml, or use commercially available solutions. Store in a polyethylene bottle.

5.1.3 Hydrochloric acid solution, $c(HCl) = 1$ mol/l.

Dilute 98,6 g of concentrated hydrochloric acid (37 %, $\rho = 1,18$ g/ml) with water to 1 000 ml or use commercially available solutions.

5.1.4 Tin(II) chloride solution.

Dissolve 50 g of tin(II) chloride dihydrate ($SnCl_2 \cdot 2H_2O$) in 40 ml of the hydrochloric acid solution (5.1.3) and dilute with water to 100 ml. Prepare a fresh solution daily.

5.1.5 Copper(II) sulfate solution.

Dissolve 200 g of copper(II) sulfate pentahydrate ($\text{CuSO}_4 \cdot 5\text{H}_2\text{O}$) in water and dilute with water to 1 000 ml.

5.2 Reagents for the photometric determination of cyanide**5.2.1 Sodium hydroxide solution, $c(\text{NaOH}) = 0,8 \text{ mol/l}$.**

Dissolve 32 g of NaOH in water and dilute with water to 1 000 ml. Store in a polyethylene bottle.

5.2.2 Glacial acetic acid, 20 % (volume fraction).

Dilute 100 ml of glacial acetic acid ($\rho = 1,049 \text{ g/ml}$) to 500 ml in a measuring cylinder with water.

NOTE 100 % glacial acetic acid ($\rho = 1,049 \text{ g/ml}$), as well as 96 % glacial acetic acid ($\rho = 1,06 \text{ g/ml}$), are commercially available.

5.2.3 N-Chloro-4-methylbenzenesulfonamide sodium salt (chloramine-T) solution.

Dissolve 0,5 g of chloramine-T trihydrate [$\text{C}_7\text{H}_7\text{ClNO}_2\text{S} \cdot \text{Na}(3\text{H}_2\text{O})$] in water in a 50 ml volumetric flask and dilute to the mark. Prepare a fresh solution daily.

5.2.4 Colour reagent.

Dilute 7,0 g of sodium hydroxide (NaOH) in 500 ml of water. Add 16,8 g of 1,3-dimethylbarbituric acid ($\text{C}_6\text{H}_8\text{O}_3\text{N}_2$), and 13,6 g of pyridine-4-carboxylic acid (isonicotinic acid) ($\text{C}_6\text{H}_5\text{NO}_2$), and dilute to 1 000 ml with water. Mix well for 1 h at 30 °C and then filter (pore size approximately 8 μm) through a pleated filter. This solution can be kept for at least 1 week, provided it is stored below 10 °C in the dark, and filtered through another pleated filter (pore size approximately 8 μm) before use.

5.2.5 Potassium cyanide stock solution, corresponding to 100 mg/l of cyanide ion.

Dissolve 250 mg of potassium cyanide (KCN) in the 0,8 mol/l sodium hydroxide solution (5.2.1) and dilute with the same sodium hydroxide solution to 1 000 ml in a volumetric flask. Standardize this solution by titration with the 0,01 mol/l silver nitrate solution (5.3.1), once each day if determinations are carried out (see Clause 9). Commercially available stock solutions may also be used. Store in the dark and at a temperature below 10 °C.

5.2.6 Potassium cyanide standard solution, corresponding to 10 mg/l of cyanide ion.

Dilute 10 ml of stock solution (5.2.5) to 100 ml in a volumetric flask using the 0,8 mol/l sodium hydroxide solution (5.2.1). Prepare daily.

5.2.7 Paranitrophenol (0,1 % *m/V*) in ethanol.

Dissolve 0,1 g of paranitrophenol in 100 ml of ethanol.

5.3 Reagents for the titrimetric determination of cyanide**5.3.1 Silver nitrate solution, $c(\text{AgNO}_3) = 0,01 \text{ mol/l}$.**

Dissolve 1,699 g of silver nitrate in approximately 400 ml of water and dilute to 1 000 ml in a volumetric flask with water. Check the actual concentration of the 0,01 mol/l silver nitrate by titration with sodium chloride in accordance with ISO 9297 on a two-weekly basis. Store this solution in the dark.

5.3.2 Silver nitrate solution, $c(\text{AgNO}_3) = 0,001 \text{ mol/l}$.

Prepare daily from the 0,01 mol/l silver nitrate solution (5.3.1). Add 25,00 ml of 0,01 mol/l silver nitrate solution to a 250 ml volumetric flask and dilute to 250 ml with water. Cover the flask with aluminium foil to exclude light.

5.3.3 Indicator solution.

Dissolve 0,02 g of 5-(4-dimethylaminobenzylidene) rhodanine in acetone and dilute with acetone to 100 ml. This solution is stable for up to 1 week if kept in the dark at ambient temperature.

6 Apparatus

Usual laboratory equipment and, in particular, the following:

6.1 Apparatus for the liberation and absorption of hydrogen cyanide.

Use the apparatus shown in Figure 1. The round-bottomed flask (9) shall be triple-necked, have a capacity of at least 500 ml and have standard conical joints (for example 29/32 central neck, 19/24 side necks). A water-cooled Liebig condenser (3) (for example 16 cm long and 30 mm in outer diameter); a 50 ml dropping funnel (5) and an air-inlet tube (7) are fitted. The connection to the absorption vessel (2) (for example 20 cm long and 2,5 cm in inner diameter) is via a transfer line (1). Standard joints are fitted to this tube to enable connection to the Liebig condenser and the absorption vessel (2). A glass tube (for example 15 cm long by 1,3 cm outer diameter) extends into the absorption vessel and this is fitted with a No. 2 glass-frit sinter (4) to ensure efficient bubbling of the liberated HCN through the absorption fluid (e.g. ISO 4793 P 160, porosity class 1 or 2.)

The recovery factor (F_{Cr}) of the liberation apparatus should be determined using potassium hexacyanoferrate(III) solution for total cyanide. A mid-range calibration standard should be used (see 9.3).

6.2 Suction.

A pump capable of sucking up to 30 l/h of air through the apparatus in Figure 1 is required. A low-power piston pump is recommended. This shall be fitted with a fine-control valve (see 13 in Figure 1) between the pump and the Dreschel bottle (see 6 in Figure 1). The Dreschel bottle is used to ensure that, if a sample contained a very high level of cyanide, no HCN would be liberated to the atmosphere.

A single flowmeter (see 12 in Figure 1) can be used to give a visual estimation of a 10 l/h to 20 l/h flow rate. All other Dreschel bottle flows can then be set visually without using flowmeters. The flow rate needs to be defined as a function of the volume of the apparatus and should be checked by determining recovery rates.

6.3 Photometer, set to a wavelength of 606 nm, with cells of optical path length 10 mm (photometric method only, see Clause 9).

6.4 Magnetic stirrer (titrimetric method only, see Clause 10).

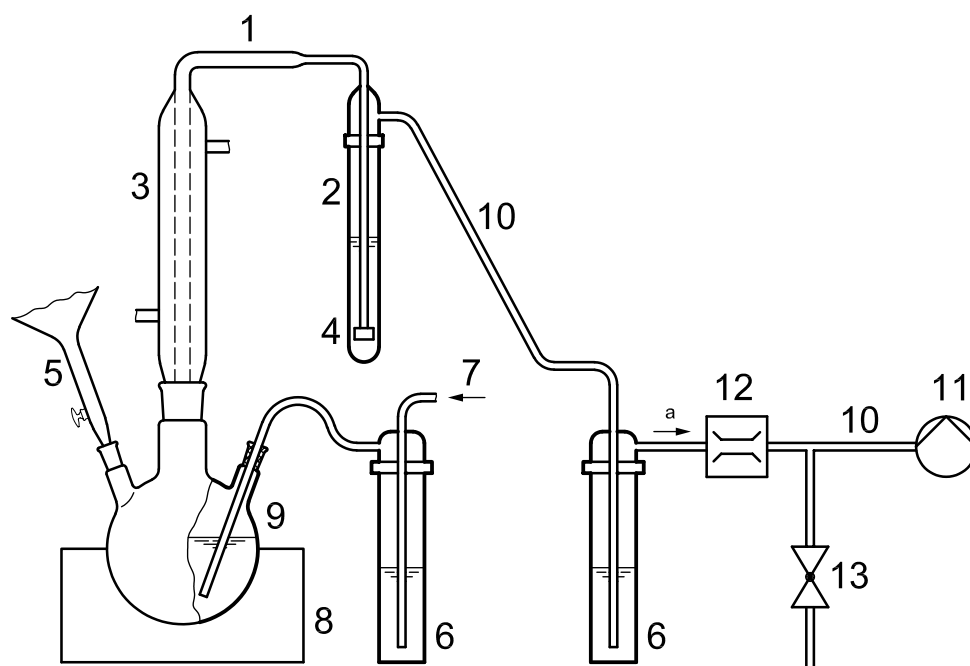

Key

- | | | | |
|---|--------------------|----|--|
| 1 | transfer line | 8 | heating device |
| 2 | absorption vessel | 9 | 500 ml 3-angled-neck round-bottomed reaction flask |
| 3 | Liebig condenser | 10 | plastic tubing |
| 4 | glass-frit sinter | 11 | pump |
| 5 | dropping funnel | 12 | flowmeter |
| 6 | Dreschel bottle | 13 | fine-control valve |
| 7 | air-inlet tube | | |
| a | Direction of flow. | | |

Figure 1 — Apparatus for the direct liberation of cyanide in soils

7 Sample preservation and preparation

7.1 Sample preservation

The sample shall be taken in a glass or polyethylene container which will not influence the analysis. Maintain the sample at a temperature below 10 °C and keep it in the dark until analysed. Analyse within 48 h after collection.

NOTE A stability study has demonstrated that refrigerated soil samples are stable for at least 4 days. See Reference [4] in the Bibliography.

7.2 Sample preparation

7.2.1 General

The sample bottle containing the field-moist sample shall not be opened prior to the analysis and weighing shall be carried out quickly to remove the test portion(s). If the soil sample cannot be homogenized, carry out at least two parallel cyanide determinations depending on the precision requirements.

7.2.2 Test portion requirements

As cyanide is labile, keep the time between removing the samples from the refrigerator and taking a test portion as short as possible. Mix the sample in the container or in a separate vessel. Remove the parts that are not representative of the soil, e.g. all visible metallic components or stones. In general, follow the procedure for volatile compounds given in ISO 14507.

7.2.3 Size fraction

A more rigorous sample pretreatment, such as crushing, grinding and sieving, is not advisable due to the labile nature of some cyanides. Therefore, the analyst will be required to make decisions, referring in particular to whether size fractions are to be combined or treated separately. This will depend on the nature of the soil and the objectives of the analytical programme. Thus, the user needs to decide how the results are to be reported and then choose the tests that need to be carried out in order to allow this. Guidance on these aspects is given in ISO 11464 and ISO 14507.

7.2.4 Moisture content determination

Carry out a moisture content determination on another test portion of the sample in accordance with ISO 11465.

8 Direct liberation using orthophosphoric acid

8.1 Procedure

Connect an absorption vessel (see 2 in Figure 1) containing 40 ml of sodium hydroxide solution (5.1.2) to the liberation unit. Weigh a quantity of the field-moist soil sample (7.2) equivalent to approximately 10 g of dry matter, accurate to 0,1 g, into the 3-angled-neck round-bottomed flask (see 9 in Figure 1), and add 160 ml of water.

Start the pump and adjust the gas flow. Pour 2 ml of tin(II) chloride solution (5.1.4), followed by 10 ml of copper(II) sulfate solution (5.1.5) into the sample through the dropping funnel. Wash any remaining solution into the flask using a small amount of water. Ensure that a small amount of water remains in the dropping funnel to maintain airtightness. Control the suction of the pump by adjusting the fine control valve (see 13 in Figure 1) appropriately to give a gas flow that ensures that all liberated HCN is carried into the absorption vessel (see 2 in Figure 1). For example 15 l/h (see the second paragraph of 6.2) are used.

It is important that the tin(II) chloride solution (5.1.4) be added prior to the copper(II) sulfate solution (5.1.5) or low results may be obtained.

Add 20 ml of orthophosphoric acid (5.1.1) through the dropping funnel and rinse the funnel with up to 6 ml of water. Ensure that 2 ml to 3 ml of liquid remain in the dropping funnel to maintain airtightness.

Heat the flask slowly and reflux gently for 120 min \pm 10 min. Ensure that the volume of the solution in the absorption vessel does not significantly increase (for example by more than 5 ml) as a result of refluxing that is too rapid. After gently refluxing for 2 h, relieve the partial vacuum in the reaction flask (see 9 in Figure 1) by slowly opening the tap on the dropping funnel (see 5 in Figure 1). Failure to carry this out will result in suck-back of the sodium hydroxide in the absorption vessels (see 2 and 6 in Figure 1) into the reaction flask (see 9 in Figure 1).

When the partial vacuum is relieved, lift the gas tube of the absorption vessel out of the sodium hydroxide solution (now containing cyanide ions from the total cyanide) and rinse the tube with up to 5 ml of water. Remove the absorption vessel, quantitatively transfer the contents to a 50 ml volumetric flask and make up to volume with water. Store at below 10 °C in the dark until the concentration of cyanide can be determined.

8.2 Blank test

Carry out a blank test in parallel with the appropriate determination, proceeding as specified in 8.1, but replacing the sample by 10 ml of cyanide-free water.

9 Determination of cyanide — Photometric method

9.1 Applicability

This method is applicable to 20 ml test aliquots of NaOH absorption solutions containing 0,002 mg to 0,020 mg of cyanide (or given as a concentration of 0,1 mg/l to 1,0 mg/l) which is within the range of calibration (9.3). NaOH absorption solutions with higher cyanide contents shall be analysed using smaller test aliquots made up to 20 ml with 0,8 mol/l NaOH solution (5.2.1). For example, if a 10 ml aliquot is used, it should be made up to 20 ml with 10 ml of 0,8 mol/l NaOH.

If 10 g of field-moist soil are used and a 20 ml aliquot is taken from the absorption solution (assumed to be made up to 50 ml), and the concentration range in the NaOH absorption solution is from 0,1 mg/l to 1,0 mg/l, this will correspond to 0,5 mg/kg to 5 mg/kg in the field-moist sample.

9.2 Procedure

Perform the following procedure on the absorption solutions prepared in 8.1 or 8.2.

Transfer, by means of a pipette, 20 ml of the absorption solutions into a series of 50 ml volumetric flasks, add 2 drops of paranitrophenol (5.2.7). Then add, whilst mixing, 20 % (volume fraction) of glacial acetic acid (5.2.2) carefully dropwise until the yellow paranitrophenol colour just turns colourless. Then add 2 ml of the chloramine-T solution (5.2.3). Stopper the flask and leave for 5 min \pm 1 min. Add 6 ml of the colour reagent (5.2.4). Dilute with water to the mark and mix. Measure the absorbance at 606 nm in a cell of optical path length 10 mm against a water reference. If further dilution is necessary, pipette a smaller aliquot of the absorption solution into a 50 ml flask and dilute to approximately 20 ml with 0,8 mol/l sodium hydroxide (5.2.1). Then follow the above procedure.

Carry out the measurement 20 min \pm 5 min after addition of the colour reagent (see last paragraph).

Measure the absorbance of the blank test solution (8.2) in the same way.

A check should be made on the time required to obtain a stable absorbance reading.

9.3 Preparation of the calibration graph

Transfer, by means of a pipette, 0 ml, 2,5 ml, 5 ml, 10 ml, 20 ml and 25 ml of the 10 mg/l potassium cyanide solution (5.2.6) into a series of six 250 ml volumetric flasks. Dilute to the mark with the 0,8 mol/l sodium hydroxide solution (5.2.1) and mix. Proceed as specified in 9.2. Plot a graph of absorbance against the amount of cyanide, in milligrams, in the solutions.

NOTE It is helpful to use the mass of cyanide in 20 ml of solution on the X-axis to facilitate calculations using Equation (1).

EXAMPLE Using 25 ml of the 10 mg/l potassium cyanide solution (5.2.6) gives a concentration of 1,0 mg/l which is equivalent to 0,02 mg/20 ml.

The relationship between absorbance and concentration shall be linear. Check the graph for linearity on a regular basis, especially if new batches of chemicals are used.

9.4 Calculation

The analyst will be required to make decisions, referring in particular to how the results are to be reported in relation to the sample (see 7.2). The calculation given below assumes that the test portion is representative of the sample received and that no removal of stones has taken place prior to removing the test portion.

Calculate the mass fraction of cyanide, expressed in milligrams per kilogram (dry matter), using Equation (1):

$$w_{\text{CN}} = \frac{(m_a - m_b) \times V_1 \times 1\,000}{V_2 \times m \times C} \times f_1 \times \frac{1}{F_{\text{rc}}} \quad (1)$$

where

- w_{CN} is the mass fraction of cyanide in the soil sample, recalculated to dry mass, in milligrams per kilogram;
- m_a is the mass of cyanide, in milligrams, in the 20 ml aliquot test solution, read from the calibration graph;
- m_b is the mass of cyanide, in milligrams, in the 20 ml blank aliquot, read from the calibration graph;
- V_1 is the volume, in millilitres, of the absorption solution (nominally 50 ml);
- V_2 is the volume, in millilitres, of the analysed sample aliquot (nominally 20 ml);
- m is the mass, in grams, of the field-moist test portion taken (nominally 10 g);
- C is the correction factor for converting field-moist to dry soil sample, $C = 100 / (100 + w_{\text{H}_2\text{O}})$;
- $w_{\text{H}_2\text{O}}$ is the mass fraction of water in the soil, expressed as a percentage (according to ISO 11465);
- F_{rc} is the recovery factor of the apparatus;
- f_1 is the dilution factor (if required) of the absorption solution in order to get the cyanide concentration of the diluted extract within the measurement range; if no dilution is used then $f_1 = 1$.

10 Determination of cyanide — Titrimetric method using an indicator

10.1 Applicability

This method is applicable to NaOH absorption solutions containing 0,05 mg to 5 mg of cyanide ions in the aliquot titrated and is not applicable if the absorption solution is significantly coloured or turbid.

Using 0,001 mol/l silver nitrate titrant, the working range is 0,05 mg to 0,5 mg of cyanide in the NaOH absorption solution aliquot titrated.

Using 0,01 mol/l silver nitrate titrant, the working range is 0,5 mg to 5 mg of cyanide in the NaOH absorption solution aliquot titrated.

NaOH absorption solutions with higher mass fractions of cyanide shall be analysed using smaller test aliquots made up to 20 ml with 0,8 mol/l NaOH solution (5.2.1). For example, if a 10 ml aliquot is used, it should be made up to 20 ml with 10 ml of 0,8 mol/l NaOH solution.

If 10 g of field-moist soil are used and a 20 ml aliquot is taken from the absorption solution (assumed to be made up to 50 ml), and the 0,001 mol/l silver nitrate titrant is used, the working range is from 0,05 mg to 0,5 mg cyanide in the NaOH absorption solution. This corresponds to 12,5 mg/kg to 125 mg/kg in the field-moist sample. A maximum titration volume of 10 ml for the silver nitrate is assumed.

Using the 0,01 mol/l silver nitrate titrant, the working range is from 0,5 mg to 5 mg of cyanide in the NaOH absorption solution; this is equivalent to 125 mg/kg to 1 250 mg/kg in the original field-moist sample.

The titration method is applicable to cyanide contents of above 50 mg/kg in the field-moist sample.

10.2 Procedure

Perform the following procedure on the absorption solutions prepared in 8.1 and 8.2.

Pipette a 20 ml aliquot (V_2) into a 50 ml glass beaker, and add 0,1 ml of the indicator solution (5.3.3), switch on the magnetic stirrer and titrate with silver nitrate solution (5.3.2) until the colour changes from yellow to red. The colour is stable only for a short time. If more than 10 ml of the 0,001 mol/l silver nitrate solution (5.3.2) is necessary, carry out the titration using the 0,01 mol/l silver nitrate solution (5.3.1) on another aliquot. If more than 10 ml of this silver nitrate solution is necessary, repeat the operation using a reduced-volume aliquot.

Pipette 20 ml of the blank test solution (8.2) into a different glass beaker and titrate in the same way. The volume of the 0,001 mol/l silver nitrate solution (5.3.2) used in this blank test is approximately 0,16 ml, but it shall not exceed 0,4 ml. This corresponds to 2 mg/kg to 5 mg/kg cyanide, respectively, for a 10 g field-moist soil aliquot.

10.3 Calculation

The analyst will be required to make decisions, referring in particular to how the results are to be reported in relation to the sample (see 7.2). The calculation given below assumes that the test portion is representative of the sample received and that no removal of stones has taken place prior to removing the test portion.

Calculate the mass fraction of cyanide, expressed in milligrams per kilogram (dry matter), using Equation (2):

$$w_{\text{CN}} = \frac{(a-b) \times f \times V_1}{V_2 \times m \times C} \times \frac{1}{F_{\text{rc}}} \quad (2)$$

where

- w_{CN} is the mass fraction of cyanide in the soil sample, recalculated to dry mass, in milligrams per kilogram;
- a is the volume, in millilitres, of 0,001 mol/l silver nitrate solution (5.3.2), or 10 times the volume of 0,01 mol/l silver nitrate solution (5.3.1), required for the titration;
- b is the volume, in millilitres, of 0,001 mol/l silver nitrate solution (5.3.2) required for the blank test;
- f = 52, i.e. the mass, in micrograms, of cyanide ion equivalent to 1 ml of 0,001 mol/l silver nitrate solution;
- V_1 is the volume, in millilitres, of the absorption solution (nominally 50 ml);
- V_2 is the volume, in millilitres, of the analysed sample aliquot (nominally 20 ml);
- m is the mass, in grams, of the field-moist test portion taken (nominally 10 g);
- C is the correction factor for moisture, $C = 100 / (100 + w_{\text{H}_2\text{O}})$;
- $w_{\text{H}_2\text{O}}$ is the mass fraction of water in the soil, expressed as a percentage (according to ISO 11465);
- F_{rc} is the recovery factor of the apparatus.

11 Expression of results

Express the results as a mass fraction, in milligrams per kilogram of dry mass of soil, using the number of digits given in Table 1.

If stones or other non-soil particles have been removed from the laboratory sample, the mass ratio or absolute masses shall be reported to allow calculations of the total sample, if required.

Table 1 — Expression of results

Mass fraction of cyanide w_{CN} mg/kg	Report results to w_{CN} mg/kg
0,5 to 10	0,5
10 to 100	1,0
100 to 1 000	10
1 000 to 10 000	100

12 Precision

Precision data are given in Annex A.

13 Test report

The test report shall contain the following information:

- a) a reference to this International Standard (ISO 11262:2011);
- b) the complete identification of the sample;
- c) a reference to the method used for the determination;
- d) the results of the determinations;
- e) mass ratio or absolute masses of stones or other non-soil particles removed from the sample, if done;
- f) any details not specified in this International Standard or which are optional, as well as any factor which may have affected the results.

Annex A (informative)

Precision data

An interlaboratory trial was conducted to test the procedures specified in this International Standard. In this trial, the amount of total cyanide was determined by a number of laboratories on a number of soils.

The repeatability (r) and reproducibility (R) of the results of these analyses are given in Table A.1. Samples 1 to 3 are contaminated soils from former gasworks sites in the area of Berlin (Germany).

The values have been calculated according to ISO 5725-2.

**Table A.1 — Validation data of the 15th BAM interlaboratory comparison “Contaminated soil”,
September 2009**

Sample	N_L	N_A	N	\bar{X} mg/kg	s_r mg/kg	V_r %	s_R mg/kg	V_R %	r mg/kg	R mg/kg
Soil 1	26	25	50	107,0	5,0	4,7	19,5	18,3	13,8	54,1
Soil 2	19	18	36	76,2	2,4	3,2	11,8	15,5	6,7	32,7
Soil 3	21	20	40	48,2	1,3	2,6	6,6	13,6	3,5	18,2
N_L	is the number of laboratories;									
N_A	is the number of accepted laboratories;									
N	is the number of accepted single values;									
\bar{X}	is the mean value;									
s_r	is the repeatability standard deviation;									
V_r	is the relative repeatability standard deviation;									
s_R	is the reproducibility standard deviation;									
V_R	is the relative reproducibility standard deviation;									
r	is the repeatability limit;									
R	is the reproducibility limit.									

Annex B (informative)

Extraction with sodium hydroxide solution and subsequent liberation using orthophosphoric acid

B.1 Introduction

The sodium hydroxide extraction can be carried out in batch mode and allows a much larger and possibly more representative test portion (up to 40 g) of the field-moist sample than the direct liberation method (especially for contaminated samples). This method is informative only because no validation data are available.

NOTE Annex C provides some data showing equivalence of the direct liberation and NaOH extraction/liberation methods for total cyanide in soils.

The procedure given in this annex for an alternative method contains all the additional information needed to carry out this procedure. The user will also need to refer to the relevant Clauses 1 to 11 that are applicable to both methods.

B.2 Principle

The field-moist sample is homogenized and pretreated in accordance with ISO 14507, removing visible coarse constituents. It is then extracted by shaking with 2,5 mol/l sodium hydroxide for 16 h. A suitable aliquot of this extract is then decomposed with an excess of orthophosphoric acid and the liberated cyanide is determined by photometry or titrimetry. Tin(II) and copper(II) salts are added to suppress the interference from sulfur compounds and catalyse the decomposition of complex cyanides during the liberation process.

B.3 Additional reagent and apparatus

B.3.1 Additional reagent for liberation and absorption of cyanide

B.3.1.1 Sodium hydroxide solution, $c(\text{NaOH}) = 2,5 \text{ mol/l}$.

Dissolve 100 g of NaOH (e.g. pellets) in water and fill up with water to 1 000 ml. Store in a polyethylene bottle.

B.3.2 Additional apparatus

B.3.2.1 Shaking machine, with a shaking motion which allows optimal contact between the sample and the extraction liquid.

NOTE Good results are obtained using an apparatus with a horizontal movement (motion) of 180 strokes/min and a stroke length of 5 cm with the 500 ml polyethylene extraction vessels in a horizontal position.

B.4 Procedure

B.4.1 Sample pretreatment

As cyanide is labile, keep the time between removing the samples from the refrigerator and taking a test portion as short as possible. Mix the sample in the container or in a separate vessel. Remove the parts that are not representative of the soil, e.g. all visible metallic components or stones. In general, follow the procedure for volatile compounds given in ISO 14507.

B.4.2 Extraction with 2,5 mol/l sodium hydroxide

Suspend a quantity of the sample equivalent to approximately 40 g of dry matter, accurate to 0,1 g, in 200 ml of 2,5 mol/l sodium hydroxide solution (B.3.1.1) in a 500 ml polyethylene bottle. Shake for 16 h using the apparatus specified in B.3.2.1.

Afterwards, filter the suspension using an analytical filter paper. Proceed with the liberation of hydrogen cyanide (B.4.3) as soon as possible but within 4 days. Care must be exercised when handling sodium hydroxide solutions (see the safety precautions).

SAFETY PRECAUTIONS — 2,5 mol/l sodium hydroxide is extremely corrosive to human tissue. It is essential that adequate eye protection be worn when handling sodium hydroxide solutions.

For mass fractions of total cyanide above 100 mg/kg, further dilution of the soil extract is necessary to cope with the photometric-method calibration range.

Extraction by shaking for 1 h with 1 mol/l sodium hydroxide solution has been found to be adequate for many samples. Before using this modification, the user should validate this extraction with a wide range of typical samples.

B.4.3 Liberation using orthophosphoric acid

After connecting an absorption vessel (see 2 in Figure 1) containing 40 ml of sodium hydroxide solution (5.1.2) to the liberation apparatus, add 20 ml of the extract (as given in B.4.2) to the 3-angled-neck round-bottomed flask (see 9 in Figure 1) and add 140 ml of water.

Then follow the procedure described in 8.1 starting with the second paragraph.

B.5 Applicability of cyanide determination procedures

B.5.1 Photometric method

This method is applicable to 20 ml test aliquots of NaOH absorption solutions containing 0,002 mg to 0,020 mg of cyanide (or given as concentration 0,1 mg/l to 1,0 mg/l) which is within the range of calibration (see 9.3). NaOH absorption solutions with higher cyanide contents shall be analysed using smaller test aliquots made up to 20 ml with 0,8 mol/l NaOH solution (5.2.1). For example, if a 10 ml aliquot is used, it should be made up to 20 ml with 10 ml of 0,8 mol/l NaOH (5.2.1).

If 40 g of field-moist soil is used and both a 20 ml aliquot from the sodium hydroxide extraction step (total 200 ml) and a 20 ml aliquot from the absorption solution (assumed to be made up to 50 ml) are taken, and if the concentration range in the absorption solution is 0,1 mg/l to 1,0 mg/l, this will correspond to 1,25 mg/kg to 12,5 mg/kg in the field-moist sample.

B.5.2 Titrimetric method using an indicator

This method is applicable to NaOH absorption solutions containing 0,05 mg to 5 mg of cyanide ions in the aliquot titrated and is not applicable if the absorption solution is significantly coloured or turbid.

- Using 0,001 mol/l silver nitrate titrant, the working range is 0,05 mg to 0,5 mg of cyanide in the NaOH absorption solution aliquot titrated.
- Using 0,01 mol/l silver nitrate titrant, the working range is 0,5 mg to 5 mg of cyanide in the NaOH absorption solution aliquot titrated.

NaOH absorption solutions with higher cyanide contents shall be analysed using smaller test aliquots made up to 20 ml with 0,8 mol/l NaOH solution (5.2.1). For example, if a 10 ml aliquot is used, it should be made up to 20 ml with 10 ml of 0,8 mol/l NaOH.

If 40 g of field-moist soil are used and both a 20 ml aliquot from the sodium hydroxide extraction step (total 200 ml), and a 20 ml aliquot from the absorption solution (assumed to be made up to 50 ml) are taken, and

the 0,001 mol/l silver nitrate titrant is used, the working range is from 0,05 mg to 0,5 mg of cyanide in the NaOH absorption solution. This corresponds to 31,3 mg/kg to 313 mg/kg in the field-moist sample. A maximum titration volume of 10 ml for the silver nitrate is assumed.

Annex C (informative)

Comparison of the direct liberation of total cyanide and sodium hydroxide extraction with subsequent liberation

Table C.1 — Comparison sample 1

Sample	Mass fraction	
	mg/kg	
Sample 1 Ref.: 54 mg/kg ± 5 mg/kg	Direct liberation, ISO 11262:2003	NaOH extraction, and subsequent liberation, ISO 17380
Mean value	50,9	50,6
Standard deviation	1,41	2,67
Relative standard deviation, %	2,77	5,29
Number of determinations	8	8

Table C.2 — Comparison sample 2

Sample	Mass fraction	
	mg/kg	
Sample 2 Ref.: 119 mg/kg ± 18 mg/kg	Direct liberation, ISO 11262:2003	NaOH extraction, and subsequent liberation, ISO 17380
Mean value	127,2	124,1
Standard deviation	4,93	1,48
Relative standard deviation, %	3,88	1,19
Number of determinations	8	8

Bibliography

- [1] ISO 4793, *Laboratory sintered (fritted) filters — Porosity grading, classification and designation*
- [2] ISO 5725-2:1994, *Accuracy (trueness and precision) of measurement methods and results — Part 2: Basic method for the determination of repeatability and reproducibility of a standard measurement method*
- [3] ISO 17380, *Soil quality — Determination of total cyanide and easily released cyanide — Continuous-flow analysis method*
- [4] Validation report NEN 6655, Determination of total and free cyanide, Deventer, May 1995, Tauw Milieu Bv. R3355527.LO1/MAO

ICS 13.080.10

Price based on 16 pages