

First edition
2012-09-15

**Ships and marine technology — Large
yachts — Deck crane and access
gangways strength requirements**

*Navires et technologie maritime — Grands yachts — Exigences de
résistance des grues de pont et des passerelles d'accès*



Reference number
ISO 11209:2012(E)



COPYRIGHT PROTECTED DOCUMENT

© ISO 2012

All rights reserved. Unless otherwise specified, no part of this publication may be reproduced or utilized in any form or by any means, electronic or mechanical, including photocopying and microfilm, without permission in writing from either ISO at the address below or ISO's member body in the country of the requester.

ISO copyright office
Case postale 56 • CH-1211 Geneva 20
Tel. + 41 22 749 01 11
Fax + 41 22 749 09 47
E-mail copyright@iso.org
Web www.iso.org

Published in Switzerland

Contents

Page

Foreword	iv
1 Scope	1
2 Terms and definitions	1
3 General requirements	2
3.1 Service class	2
3.2 Applied loads	2
3.3 Design criteria	9
4 Strength check	11
4.1 Metallic materials	11
4.2 Composite materials	13
5 Buckling check	13
6 Deflection check	13
7 Connections	13
8 Miscellaneous	13
8.1 Ropes	13
8.2 Fittings	14
8.3 Foundations	14
9 Rest condition	14
Bibliography	15

Foreword

ISO (the International Organization for Standardization) is a worldwide federation of national standards bodies (ISO member bodies). The work of preparing International Standards is normally carried out through ISO technical committees. Each member body interested in a subject for which a technical committee has been established has the right to be represented on that committee. International organizations, governmental and non-governmental, in liaison with ISO, also take part in the work. ISO collaborates closely with the International Electrotechnical Commission (IEC) on all matters of electrotechnical standardization.

International Standards are drafted in accordance with the rules given in the ISO/IEC Directives, Part 2.

The main task of technical committees is to prepare International Standards. Draft International Standards adopted by the technical committees are circulated to the member bodies for voting. Publication as an International Standard requires approval by at least 75 % of the member bodies casting a vote.

Attention is drawn to the possibility that some of the elements of this document may be the subject of patent rights. ISO shall not be held responsible for identifying any or all such patent rights.

ISO 11209 was prepared by Technical Committee ISO/TC 8, *Ships and marine technology*, Subcommittee SC 12, *Ships and marine technology — Large yachts*.

Ships and marine technology — Large yachts — Deck crane and access gangways strength requirements

1 Scope

This International Standard specifies requirements for the minimum structural scantling of lifting appliances for large yachts.

It is applicable to the following lifting appliances:

- cranes;
- access gangways (including side ladders);
- access gangways when used as a lifting appliance.

This International Standard is not applicable to lifting means for life saving appliances, which are covered by recognized rules and/or international regulations.

This International Standard covers mainly the following aspects:

- service class;
- applied loads;
- design criteria;
- allowable stresses;
- strength check;
- elastic stability check;
- connections.

2 Terms and definitions

For the purposes of this document, the following terms and definitions apply.

2.1

large yacht

ship with a hull length, L_H , equal to or higher than 24 m, used for sport or pleasure and commercial operations

NOTE For a definition of L_H , see ISO 8666.

2.2

lifting appliance

means of loading/unloading weights on board, excluding people loads

2.3

access gangway

means of embarking/disembarking people

2.4

life saving appliance

survival craft

EXAMPLE Life boat, rescue boat, inflatable life raft, rigid life raft.

2.5

favourable weather condition

steady wind up to Beaufort Force 4

2.6

calm water

sea state with waves up to 0,3 m significant height

2.7

wave significant height

mean height of the highest one third of the waves

NOTE Wave significant height approximately corresponds to the wave height estimated by an experienced observer.

2.8

jib type crane

crane (either rotating or not) with arm (either hoistable or not)

2.9

gantry crane

beam or carriage, with lifting device, running on guides

2.10

light service class

class used to refer to lifting of general equipment and supplies

3 General requirements

3.1 Service class

For the purposes of this International Standard, a light service class shall be considered, and the following load amplification factor M (service factor) shall be applied:

$$M = 1,05$$

3.2 Applied loads

3.2.1 General

The following load evaluation takes into account that the lifting appliances are to be operated in favourable weather conditions and in calm waters.

The following loads shall be considered:

- main loads acting statically on the lifting appliance structure;
- inertia forces due to lifted load vertical movement;
- inertia forces due to lifting appliance movements;
- static loads due to yacht trim and list.

3.2.2 Main loads

The following loads are defined as main loads (see Figure 1):

- P_S : weight (N) of lifting appliance structure;
- P_F : weight (N) of fittings and mechanical parts permanently connected to the lifting appliance;

- P_L : service load (N) (maximum weight to be lifted);
- P_M : weight (N) of mobile fittings lifted together with service load.

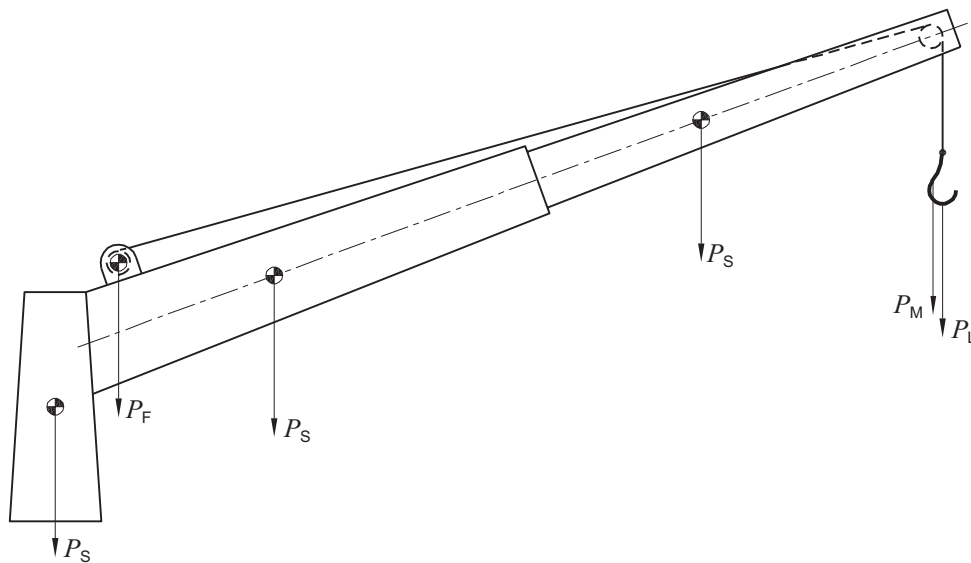
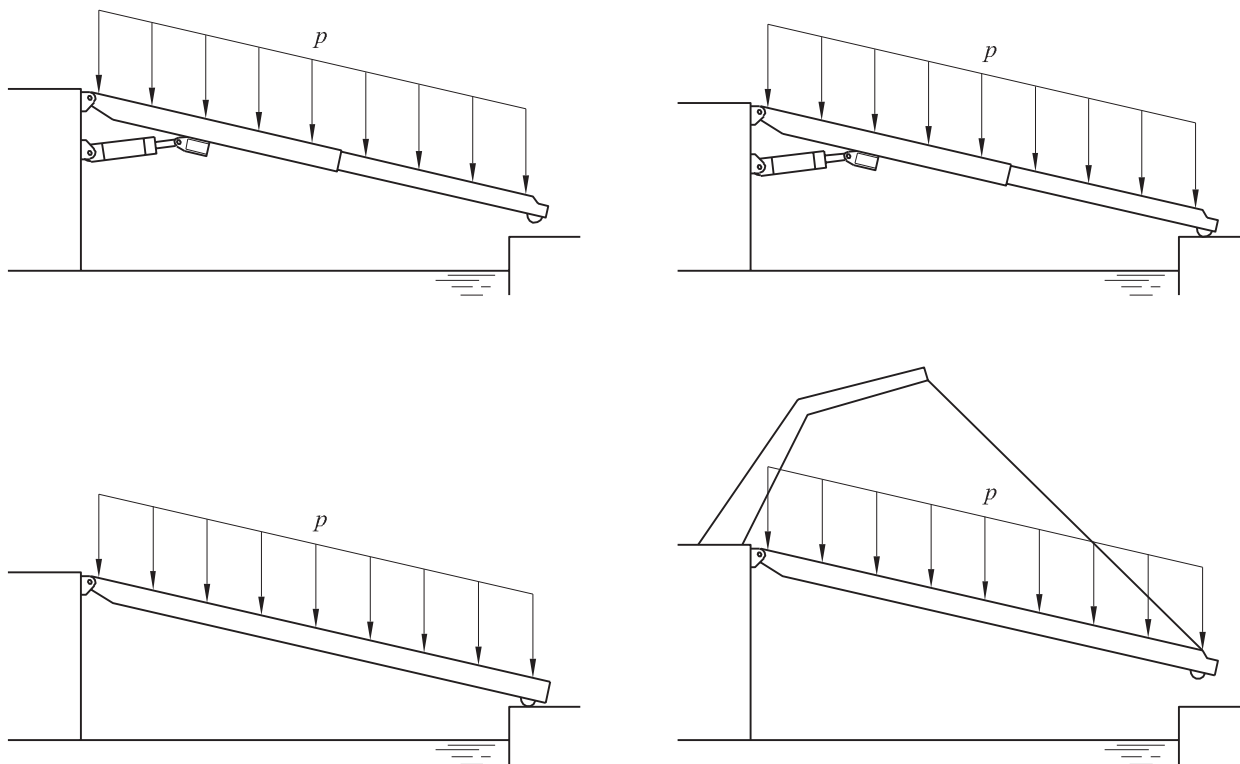

Figure 1 — Main loads

The service load (P_L) shall be declared by the manufacturer, marked on the lifting appliance and listed in the user's manual.

For access gangways, the service load (type and value) for which the appliance is designed shall be clearly declared and marked on the gangway, and shall be listed in the user's manual. For example the access gangway load can be defined as a uniformly distributed load (p in Figure 2) or as a number of concentrated loads P (people accessing the yacht) for which the following data shall be defined (Figure 3):

- number of loads;
- amount of each load;
- position of loads along the access gangway.



Key

p distributed load

Figure 2 — Uniformly distributed load

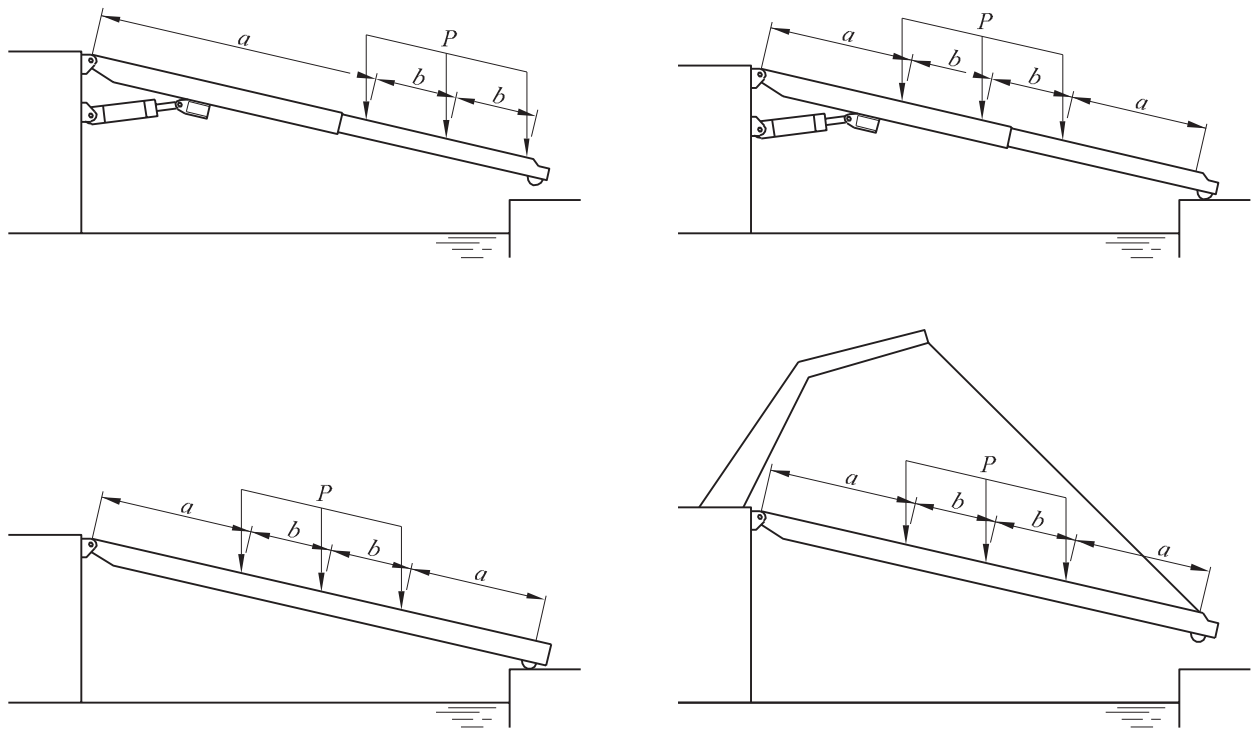

Key

- P* concentrated loads
- a* distance from the load to the end of the gangway
- b* distance between the concentrated loads

Figure 3 — Concentrated loads

For gangways that can be used either hanging free above the quay or with the end supported by the quay, the maximum load to be marked is that resulting from the worst loading condition.

When the access gangway can also be used as a crane, the structural check shall be carried out for the two separate loading cases.

3.2.3 Inertia loads due to lifted load vertical movement

To take into account the inertia force due to lifted load vertical movement, the loads P_L and P_M shall be multiplied by the dynamic factor ψ given by:

$$\psi = 1 + K v_S \tag{1}$$

where:

- K* is the coefficient = 0,3 (jib type crane), 0,6 (gantry crane);
- v_S is the load lifting velocity (m/s), to be taken as no more than 1.

Factor ψ , to be taken as not less than 1,15, is given in Figure 4.

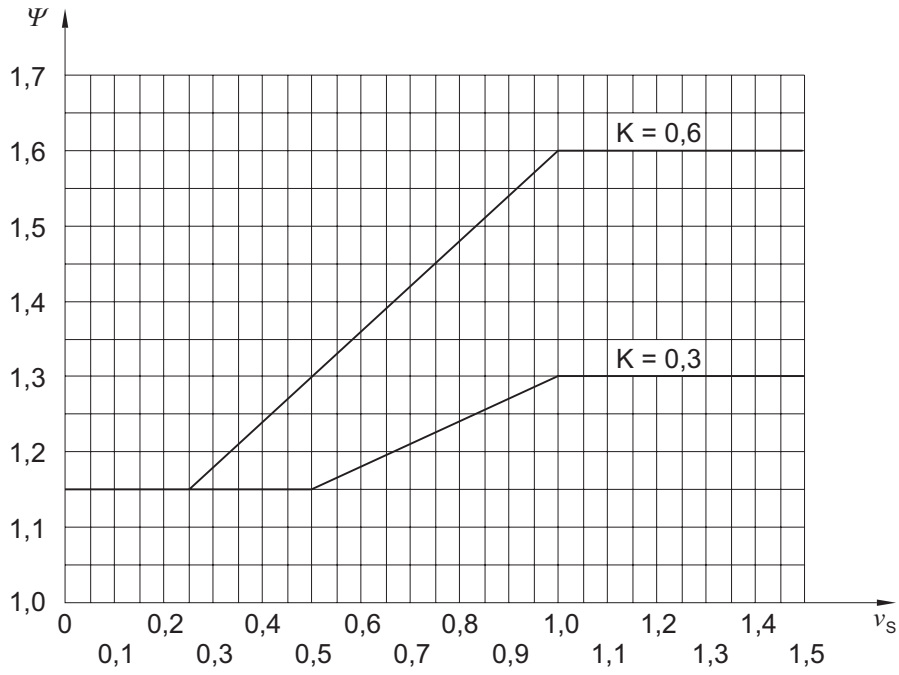

Figure 4 — Dynamic factor

3.2.4 Inertia loads due to lifting appliance horizontal translation

The force due to horizontal translation, P_t , is as follows:

$$P_t = M (P_L + P_M) a_t/g \tag{2}$$

where:

a_t is the translating acceleration (m/s²);

g is gravity acceleration (9,81 m/s²).

If acceleration a_t is not specified, it can be obtained from Figure 5 as a function of translating speed v_t .

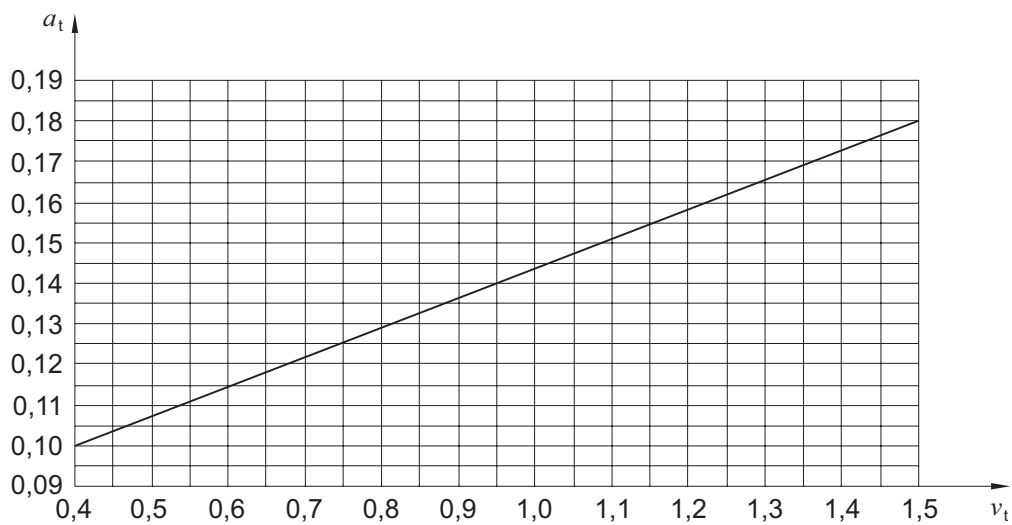

Figure 5 — Translating acceleration

3.2.5 Inertia loads due to lifting appliance slewing

The force due to slewing, P_r , is as follows:

$$P_r = M (P_L + P_M) a_r / g \quad (3)$$

where a_r is the slewing acceleration (m/s^2).

If acceleration a_r is not specified, it can be assumed to be $0,6 (m/s^2)$ at the jib head at maximum outreach.

3.2.6 Loads due to yacht trim and list

Unless higher values are specified, all the combinations of the following angles shall be considered, according to the location on board and the degree of freedom of the lifting appliance:

List	- 5°	0°	+ 5°
Longitudinal trim	- 2°	0°	+ 2°

as in the following examples, where (see Figure 6):

- θ is the transversal angle of the lifting appliance arm;
- β is the longitudinal angle of the lifting appliance arm.

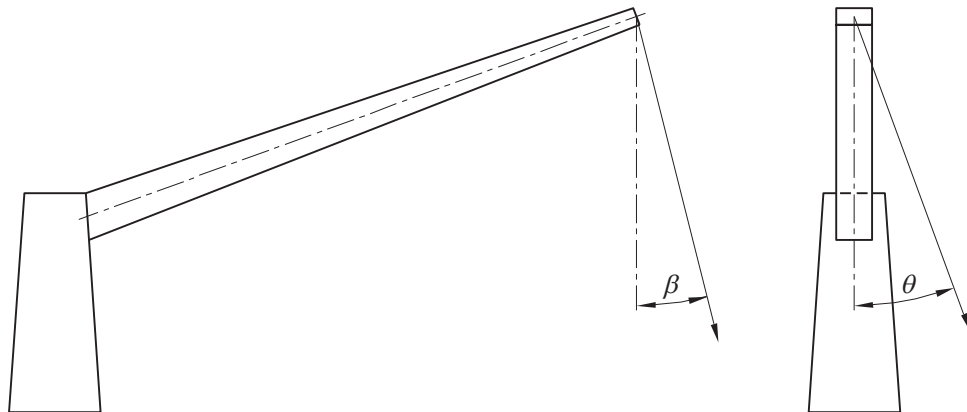
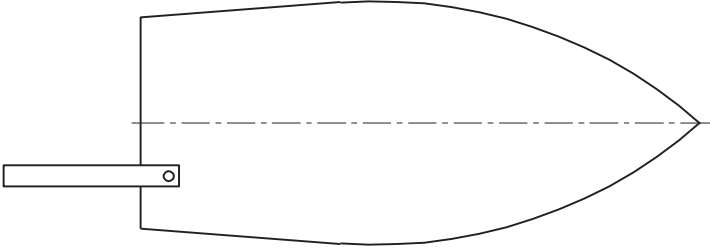
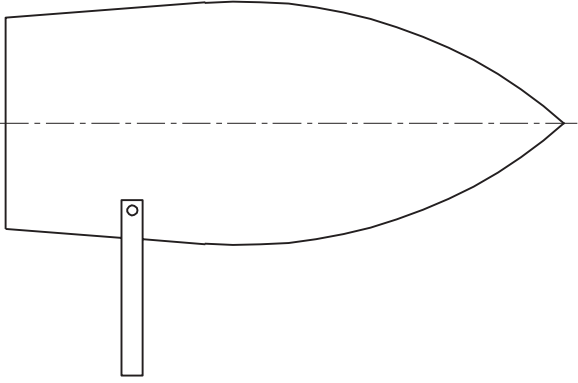

Figure 6 — Lifting appliance angles

Example No. 1 — Non-rotating lifting appliance fitted in longitudinal direction		
	θ	β
	0	0
	0	-2
	0	+2
	5	0
	5	-2
	5	+2

Example No. 2 — Non-rotating lifting appliance fitted in transversal direction		
	θ	β
	0	0
	0	-5
	0	+5
	2	0
	2	-5
	2	+5

Example No. 3 — Rotating lifting appliance		
	θ	β
	0	0
	0	-2
	0	+2
	5	0
	5	-2
	5	+2
	0	-5
	0	+5
	2	0
	2	-5
	2	+5

3.3 Design criteria

The following forces shall be considered as acting simultaneously:

P_L : service load (N) (maximum weight to be lifted);

P_M : weight (N) of mobile fittings lifted together with service load;

P_S : weight (N) of lifting appliance structure;

P_F : weight (N) of fittings and mechanical parts permanently connected to the lifting appliance;

also taking into account the service factor M and the dynamic factor ψ .

The design total load on lifting appliance is, in general, as follows:

$$P_T = M [(P_S + P_F) + \psi (P_L + P_M)] \text{ (N)} \tag{4}$$

where the components (horizontal and vertical) of loads P shall be considered with their relevant action line and direction (see Figure 7).

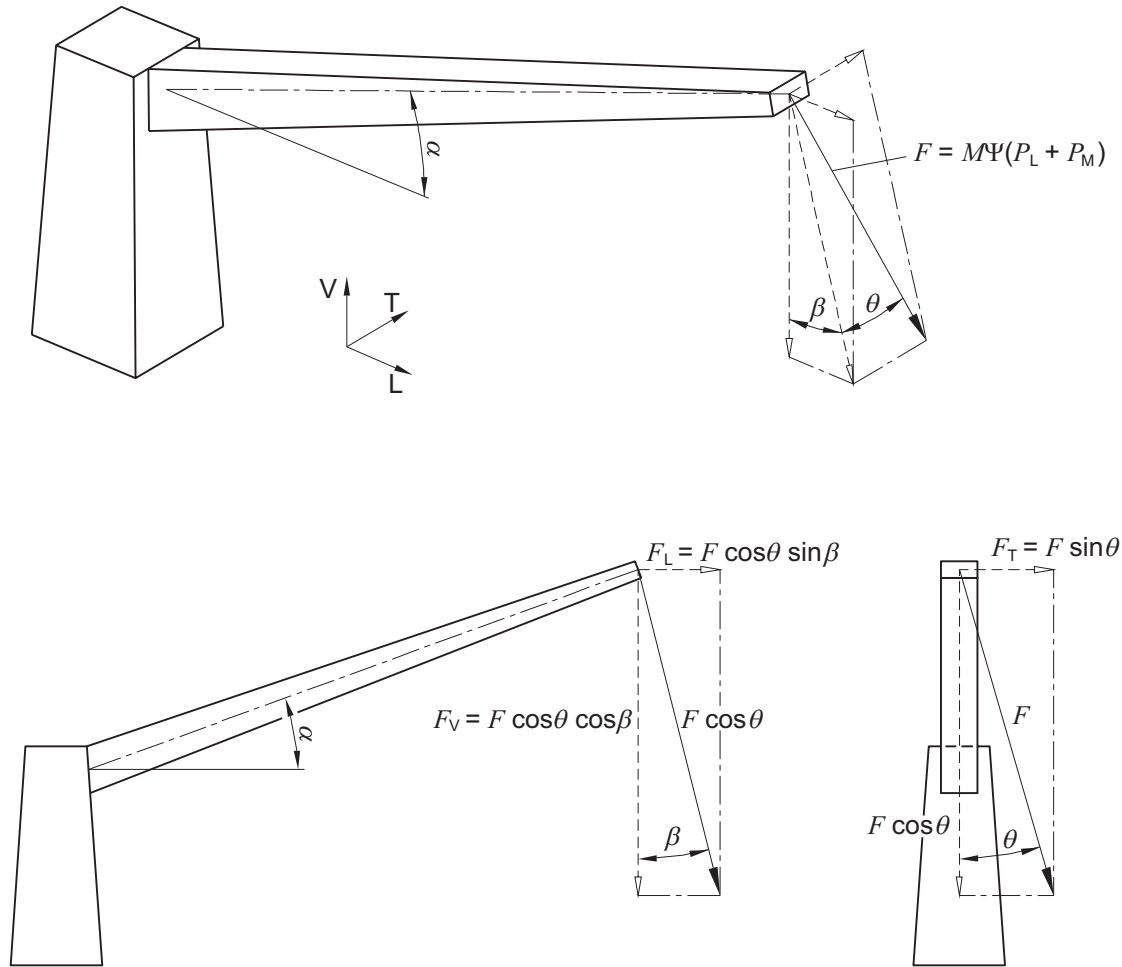

Figure 7 — Lifted load

The inertia loads due to lifting appliance movements shall be taken into account and the forces P_t and P_r shall be applied in addition to the above forces (see Figures 8 and 9).

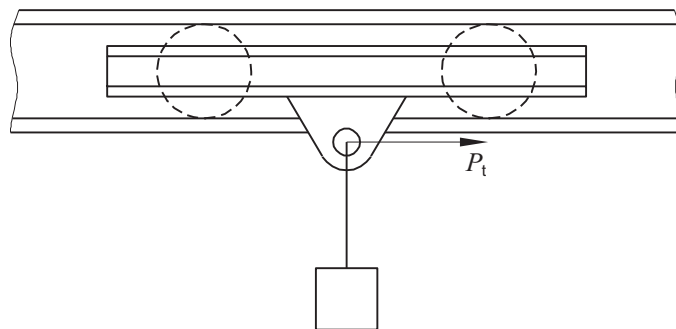

Figure 8 — Horizontal translation force

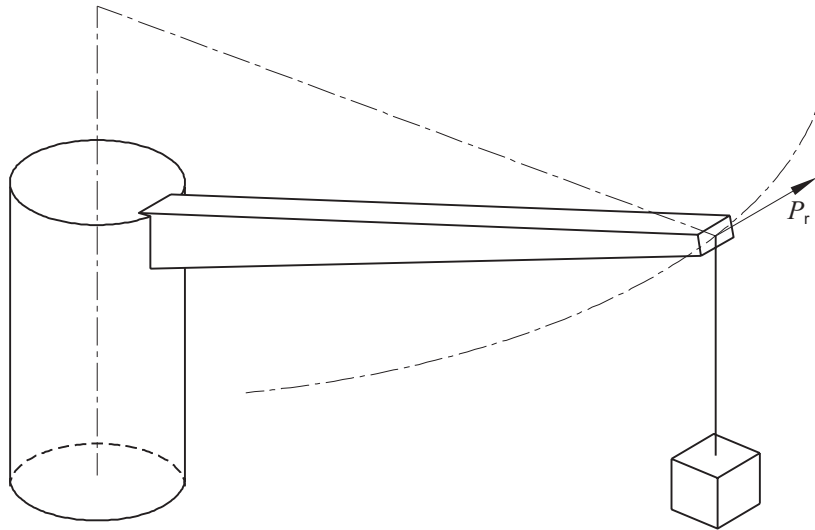

Figure 9 — Slewing force

The scheme of Figure 7 applies also to the weights of the lifting appliance (located according to their distribution), where:

$$F = M (P_S + P_F) \text{ (N)} \quad (5)$$

The schemes of Figure 8 and Figure 9 apply also to the weights of the lifting appliance, where:

$$P_t = M (P_S + P_F) a_t/g \text{ (N)} \quad (6)$$

$$P_r = M (P_S + P_F) a_r/g \text{ (N)} \quad (7)$$

The dynamic factor ψ shall be taken as 1 when the lifted load movement is not foreseen to be simultaneous to any other appliance movement (i.e. slewing, translating).

The most unfavourable working angle in vertical plane α of crane arm or access gangway shall be considered.

It is assumed that the gangways are free to move on the quay, due to wheels or rollers on the free end, so no horizontal reaction force from the quay shall be taken into account.

For gangways with wheels on the quay side, if it is possible that only one wheel will be in contact with the quay, the arising effects on the structure shall be taken into account.

4 Strength check

4.1 Metallic materials

With reference to the above design criteria, the resulting stresses (evaluated with a simple beam theory approach or with finite element analysis) shall be not greater than the following allowable ones (according to the relevant construction material) applicable to lifting appliances operated only in favourable weather conditions and in calm waters.

If the lifting appliance is also to be operated in different weather and water conditions, additional structural checks, taking into account inertia loads due to yacht movements (depending on yacht characteristics and lifting appliance location on board), shall be carried out; in this case the allowable stresses listed below can be increased by 25%.

The equivalent stress (N/mm²) is defined as follows:

$$\sigma_{\text{eq}} = \pm \sqrt{\sigma_x^2 + \sigma_y^2 - \sigma_x \sigma_y + 3\tau_{xy}^2} \quad (8)$$

where

σ_x is the bending and axial stress (N/mm²) in x direction;

σ_y is the bending and axial stress (N/mm²) in y direction;

τ_{xy} is the shear stress (N/mm²).

4.1.1 Carbon steel

Allowable stresses:

$$\text{Bending and axial stress: } \sigma_a = \min \left(\frac{R_y}{1,5} ; \frac{R_t}{2,15} \right) \text{ (N/mm}^2\text{)} \quad (9)$$

$$\text{Shear stress: } \tau_a = \frac{\sigma_a}{\sqrt{3}} \text{ (N/mm}^2\text{)} \quad (10)$$

$$\text{Equivalent stress: } \sigma_a = \min \left(\frac{R_y}{1,5} ; \frac{R_t}{2,15} \right) \text{ (N/mm}^2\text{)} \quad (11)$$

$$\text{Bearing stress: } p_a = \frac{R_y}{1,1} \text{ (N/mm}^2\text{)} \quad (12)$$

where R_y (N/mm²) is the yield limit and R_t (N/mm²) is the tensile strength of the material.

4.1.2 Stainless steel

Allowable stresses:

$$\text{Bending and axial stress: } \sigma_a = \min \left(\frac{R_{0,2}}{1,5} ; \frac{R_t}{2,15} \right) \text{ (N/mm}^2\text{)} \quad (13)$$

$$\text{Shear stress: } \tau_{\text{am}} = \frac{\sigma_a}{\sqrt{3}} \text{ (N/mm}^2\text{)} \quad (14)$$

$$\text{Equivalent stress: } \sigma_a = \min \left(\frac{R_{0,2}}{1,5} ; \frac{R_t}{2,15} \right) \text{ (N/mm}^2\text{)} \quad (15)$$

$$\text{Bearing stress: } p_a = \frac{R_{0,2}}{1,1} \text{ (N/mm}^2\text{)} \quad (16)$$

where $R_{0,2}$ (N/mm²) is the 0,2% proof stress and R_t (N/mm²) is the tensile strength of the material.

4.1.3 Aluminium alloy

Allowable stresses:

$$\text{Bending and axial stress: } \sigma_a = \min \left(\frac{R_{0,2}}{1,7} ; \frac{R_t}{2} \right) \text{ (N/mm}^2\text{)} \quad (17)$$

$$\text{Shear stress: } \tau_{\text{am}} = \frac{\sigma_a}{\sqrt{3}} \text{ (N/mm}^2\text{)} \quad (18)$$

$$\text{Equivalent stress: } \sigma_a = \min \left(\frac{R_{0,2}}{1,7} ; \frac{R_t}{2} \right) \text{ (N/mm}^2\text{)} \quad (19)$$

$$\text{Bearing stress: } p_a = \frac{R_{0,2}}{1,1} \text{ (N/mm}^2\text{)} \quad (20)$$

where $R_{0,2}$ (N/mm²) is the 0,2% proof stress and R_t (N/mm²) is the tensile strength of the material.

4.2 Composite materials

Reference shall be made to Tsai-Wu failure criterion with the introduction of a safety factor (F_s), as follows, to evaluate a safe limit state of stress:

$$F_i \sigma_i + F_{ij} \sigma_i \sigma_j \leq \frac{1}{F_s} \quad (21)$$

where:

$F_s = 2$: structural check in favourable weather conditions and in calm waters;

$F_s = 1,6$: additional structural check in conditions different from favourable weather and calm waters (inertia loads due to yacht movements taken into account).

5 Buckling check

Elastic stability checks, global and local, shall be carried out with reference to recognized standards.

6 Deflection check

In addition to the above checks, for gangways made of aluminium and composite materials only, it shall be checked that the maximum deflection δ (mm) complies with the following limits:

$$\text{Gangway supported at both ends: } \delta_{\max} = \frac{L}{200}$$

$$\text{Gangway hanging free above quay (cantilever beam): } \delta_{\max} = \frac{L}{100}$$

where L (mm) is the unsupported length of the gangway.

7 Connections

Connections by bolting and/or welding shall be designed according to recognized standards.

8 Miscellaneous

8.1 Ropes

The maximum safe working load ($P_{S,\max} = P_L + P_M$) of ropes is given by applying a safety factor F_s to their minimum breaking load ($P_{B,\min}$):

$$P_{S,\max} = \frac{P_{B,\min}}{F_s} \quad (22)$$

Wire ropes: $F_s = 5$.

Natural and synthetic fibre ropes: F_s according to Table 1.

Table 1 — F_s in terms of rope diameter

Rope diameter (mm)	F_s
< 14	12
14/17	10
> 17	7

8.2 Fittings

Fittings (hooks, sheaves, etc.) shall be in accordance with recognized standards.

Sheaves shall have a minimum throat diameter not less than 14 times that of wire rope diameter and 5,5 times that of fibre rope diameter.

8.3 Foundations

The foundations of the lifting appliances are an important part of the yacht structure, and the maximum values of forces (horizontal and vertical) and moments (bending and torsion) transferred by the lifting appliance to the yacht structures shall therefore be communicated to the yacht manufacturer.

9 Rest condition

After the operating condition structural check, the maximum allowable vertical acceleration with the lifting appliance in rest condition (no applied load, only the weight of the lifting appliance considered) shall be specified by the manufacturer.

The maximum allowable external load due to embarking tenders on side ladders and gangways, without other loads applied, shall be specified by the manufacturer.

Bibliography

- [1] ISO 8666, *Small craft — Principal data*

ICS 47.040

Price based on 15 pages