

INTERNATIONAL STANDARD

ISO
11199-1

First edition
1999-08-01

Walking aids manipulated by both arms — Requirements and test methods —

Part 1: Walking frames

*Aides à la marche manipulées avec les deux bras — Exigences et
méthodes d'essai —*

Partie 1: Cadres de marche



Reference number
ISO 11199-1:1999(E)

Contents

1 Scope	1
2 Normative references	1
3 Terms and definitions	1
4 Requirements	4
5 Test methods	6
6 Marking and labelling	12
7 Test report	12
Annex A (informative) Recommendations	13

© ISO 1999

All rights reserved. Unless otherwise specified, no part of this publication may be reproduced or utilized in any form or by any means, electronic or mechanical, including photocopying and microfilm, without permission in writing from the publisher.

International Organization for Standardization
Case postale 56 • CH-1211 Genève 20 • Switzerland
Internet iso@iso.ch

Printed in Switzerland

Foreword

ISO (the International Organization for Standardization) is a worldwide federation of national standards bodies (ISO member bodies). The work of preparing International Standards is normally carried out through ISO technical committees. Each member body interested in a subject for which a technical committee has been established has the right to be represented on that committee. International organizations, governmental and non-governmental, in liaison with ISO, also take part in the work. ISO collaborates closely with the International Electrotechnical Commission (IEC) on all matters of electrotechnical standardization.

International Standards are drafted in accordance with the rules given in the ISO/IEC Directives, Part 3.

Draft International Standards adopted by the technical committees are circulated to the member bodies for voting. Publication as an International Standard requires approval by at least 75 % of the member bodies casting a vote.

International Standard ISO 11199-1 was prepared by Technical Committee ISO/TC 173, *Technical systems and aids for disabled or handicapped persons*.

ISO 11199 consists of the following parts, under the general title *Walking aids manipulated by both arms — Requirements and test methods*:

— *Part 1: Walking frames*

— *Part 2: Rollators*

Annex A of this part of ISO 11199 is for information only.

.....

Walking aids manipulated by both arms — Requirements and test methods —

Part 1: Walking frames

1 Scope

This part of ISO 11199 specifies requirements and methods of testing fatigue, static load capacity and stability of walking frames without accessories, unless specified in the particular test procedure. This part of ISO 11199 also gives the requirements relating to safety, ergonomics, performance, marking and labelling.

The requirements and tests are based on everyday usage of walking frames manufactured for a user mass of not less than 35 kg.

NOTE Recommendations further to the requirements given in this part of ISO 11199 are given in annex A.

2 Normative references

The following normative documents contain provisions which, through reference in this text, constitute provisions of this part of ISO 11199. For dated references, subsequent amendments to, or revisions of, any of these publications do not apply. However, parties to agreements based on this part of ISO 11199 are encouraged to investigate the possibility of applying the most recent editions of the normative documents indicated below. For undated references, the latest edition of the normative document referred to applies. Members of ISO and IEC maintain registers of currently valid International Standards.

ISO 9999:1998, *Technical aids for disabled persons — Classification*.

ISO 10933-1, *Biological evaluation of medical devices — Part 1: Evaluation and testing*.

3 Terms and definitions

For the purposes of this part of ISO 11199, the following terms and definitions apply (see also Figures 1, 2 and 3).

3.1

folded dimensions

height, width and length of the walking frame measured with the frame folded together without the use of tools, the height adjustment at its minimum height and the handles positioned as in 5.1.

3.2

frame height

vertical distance from the rear handgrip reference point to the ground

See Figure 3.

3.3**front handgrip reference point**

that point on the upper surface of the handgrip located 30 mm from the front end of the handgrip length

See Figure 2.

3.4**handgrip**

that part of the walking frame which is normally held by the hand when the frame is in use

3.5**handgrip length**

dimension of the handgrip measured longitudinally where the hand rests

See Figure 2.

NOTE Where the front end or the rear end of the handgrip is not clear, the full length of the handgrip that can support the weight of the user is defined as the handgrip length.

3.6**handgrip width**

outside dimension of the handgrip measured horizontally at the thickest point where the hand rests

See Figure 2.

3.7**handle**

that part of the walking frame to which the handgrip is attached.

3.8**maximum length**

maximum outside dimension of a walking frame when the height adjustment is at its maximum, measured parallel to the direction of movement when the frame is in normal use

See Figure 3.

3.9**maximum width**

maximum outside dimension of a walking frame when the height adjustment is at its maximum, measured horizontally at right angles to the direction of movement when the frame is in normal use

See Figure 3.

3.10**rear handgrip reference point**

that point on the upper surface of the handgrip located 30 mm from the rear end of the handgrip length

See Figure 2.

NOTE If the grip protrudes further than the handle, the measurement is made from the end of the handle.

3.11**tip**

that part of a walking frame which is in contact with the ground

3.12**turning diameter**

diameter of the largest circle described by a walking frame when the height adjustment is at its maximum and the walking frame is turned through 360° about its own central vertical axis

See Figure 3.

3.13**user weight**

body mass of the person using the product as a technical aid

NOTE Standard user weight is 100 kg for adults and 35 kg for children.

3.14**walking frame**

walking aid without wheels and with no support devices other than handles

NOTE Classification No. 12 06 03 in accordance with ISO 9999:1998.

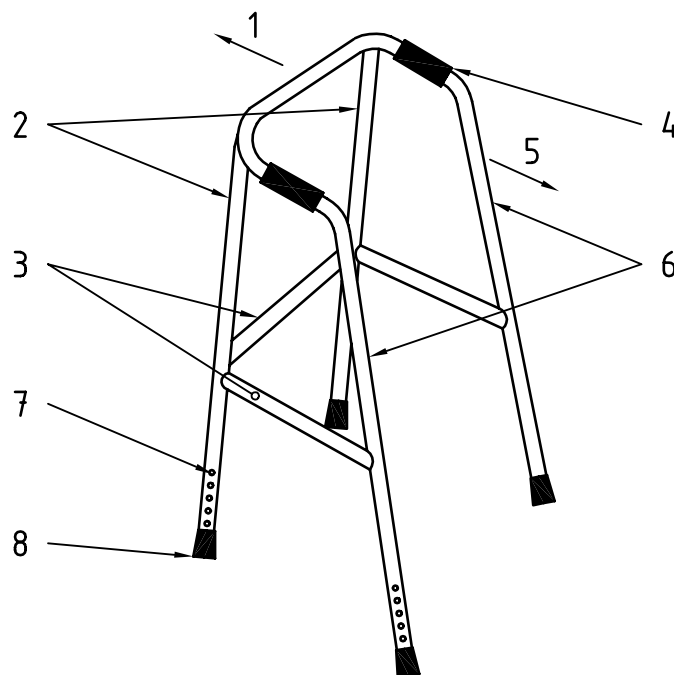
**Key**

- 1 Front
- 2 Front legs
- 3 Bracing members
- 4 Handgrip
- 5 Rear
- 6 Rear legs
- 7 Head adjustment mechanism
- 8 Tip

Figure 1 — Example of a walking frame

Dimensions in millimetres

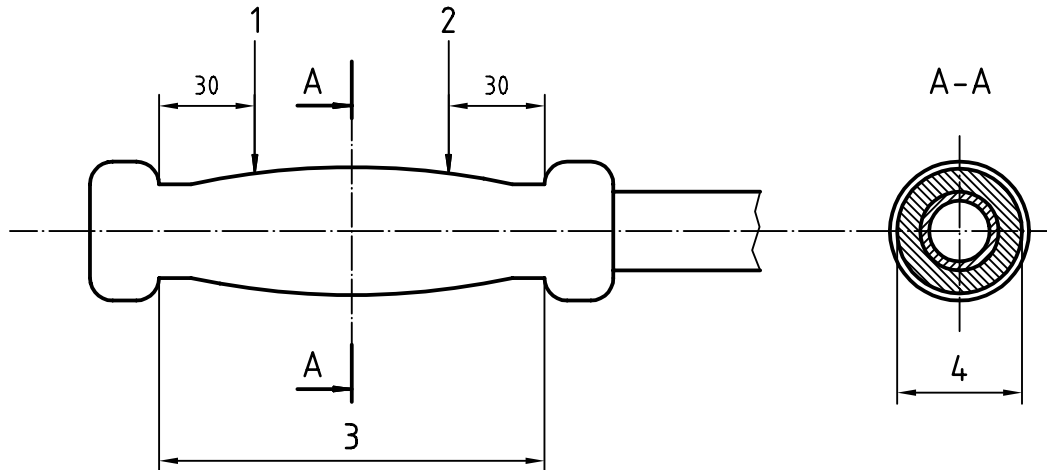

Key

- 1 Rear handgrip reference point
- 2 Front handgrip reference point
- 3 Handgrip length
- 4 Handgrip width

Figure 2 — Details of a handgrip

4 Requirements

4.1 Mechanical durability

When tested according to the fatigue test (5.3), no part of the walking frame shall crack or break.

When tested according to the static loading test (5.4), no part of the frame shall crack or break.

When tested according to the static leg-strength test (5.5), none of the legs shall crack, break or show any permanent set of more than 15 mm, measured at the end of the leg.

4.2 Stability

When tested according to the forward stability test (5.6), the angle of the plane at the point of walking frame tilting shall be not less than 10,0°.

When tested according to the backward stability test (5.7), the angle of the plane at the point of walking frame tilting shall be not less than 7,0°.

When tested according to the sideways stability test (5.8), the angle of the plane at the point of walking frame tilting shall be not less than 3,5°.

It is acknowledged that a reciprocal walking frame cannot meet this sideways stability requirement. Therefore, an analysis of the risks related to the instability shall be assessed by the manufacturer, and appropriate guidance and warnings on limitations for use shall be given.

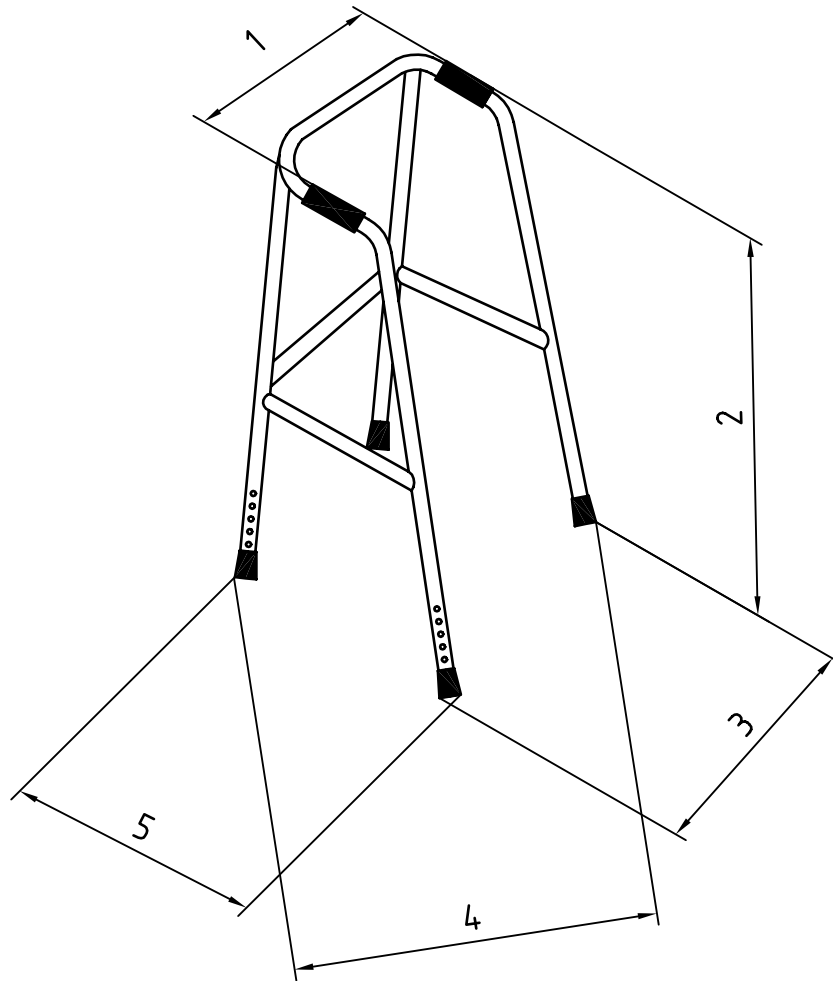
**Key**

- 1 Width between handles
- 2 Height
- 3 Width
- 4 Turning diameter
- 5 Length

Figure 3 — Dimensions of a walking frame

4.3 Manoeuvrability

Maximum width of a walking frame manufactured for use in private homes shall be not larger than 650 mm.

The width of reciprocating walking frames, when reciprocated, shall be not less than 90 % of maximum width.

4.4 Handgrip

The handgrip width shall be not less than 20 mm and not more than 50 mm.

NOTE This requirement does not apply to anatomic handgrips.

The handgrip shall be replaceable or easy to clean.

4.5 Leg section and tip

The leg section shall end in a tip of a design which will prevent the leg section from piercing through it when used as intended by the manufacturer. See also 4.1.

The tip shall be replaceable.

The tip shall not cause discolouring of the walking surface, as verified by visual inspection.

That part of the tip that contacts the walking surface shall have a minimum diameter of 35 mm. Compliance shall be verified by visual inspection.

4.6 Adjusting devices

Each of the height adjustments shall be clearly marked with its maximum allowable elongation.

After the fatigue test (5.3), the adjustment/folding mechanisms shall operate as intended by the manufacturer.

Folding walking frames shall lock into working position when unfolded.

4.7 Materials and finish

Taking into account the intended use and contact by those involved in user care or transportation and storage of the product, walking frame materials which come into contact with the human body shall be assessed for biocompatibility using the guidance given in ISO 10993-1.

The walking frame materials shall not cause discolouring of skin or clothing when the frame is in normal use.

All parts of the walking frame shall be free from burrs, sharp edges or projections that could cause damage to clothing or discomfort to the user.

5 Test methods

5.1 General

Walking frames are grouped into six sizes, as given in Table A.1.

All tests, if not otherwise specified, shall be performed at an ambient temperature of $21\text{ °C} \pm 5\text{ °C}$.

If not otherwise specified, all tests shall be performed with the height adjustments at their maximum. The handles shall be positioned at their maximum angle as specified by the manufacturer relative to the line of motion. When the longitudinal centreline of the handle and the direction of forward motion are parallel, the angle is 0 ° . The angle shall always be recorded.

5.2 Sampling and inspection

One walking frame shall be tested. The sequence of the tests shall be as follows: stability, static load, fatigue and static leg-strength.

Immediately before testing, the walking frame shall be inspected to check compliance with this part of ISO 11199. Any apparent defects shall be noted so that they shall not later be recorded as having been caused by the tests.

5.3 Fatigue test

5.3.1 Loading geometry

The height adjustment and the handles shall be positioned as given in 5.1 and the frame shall be placed with its tips on a horizontal surface. The loading force shall be applied vertically to the walking frame as shown in Figure 4. The loading line shall pass through the midpoint of the line joining the rear handgrip reference points of the two handgrips.

5.3.2 Loading force

A cyclic force of $800 \text{ N} \pm 2 \%$ shall be applied. If the maximum user weight specified for the frame deviates from the standard maximum user weight of 100 kg, a force of 8,0 N per kilogram of maximum user weight, $\pm 2 \%$, shall be applied. The load shall be not less than $280 \text{ N} \pm 2 \%$.

5.3.3 Loading frequency

The frequency of the cyclic loading shall not exceed 1 Hz.

5.3.4 Loading cycles

The number of cycles shall be 200 000.

5.4 Static loading test

5.4.1 Loading geometry

A vertical loading force shall be applied to the walking frame as specified in 5.3.1 and as shown in Figure 4.

5.4.2 Loading force

The loading force shall be $1\,500 \text{ N} \pm 2 \%$. If the maximum user weight specified for the frame deviates from the standard maximum user weight of 100 kg, a force of 15,0 N per kilogram of maximum user weight, $\pm 2 \%$, shall be applied. The load shall be not less than $525 \text{ N} \pm 2 \%$.

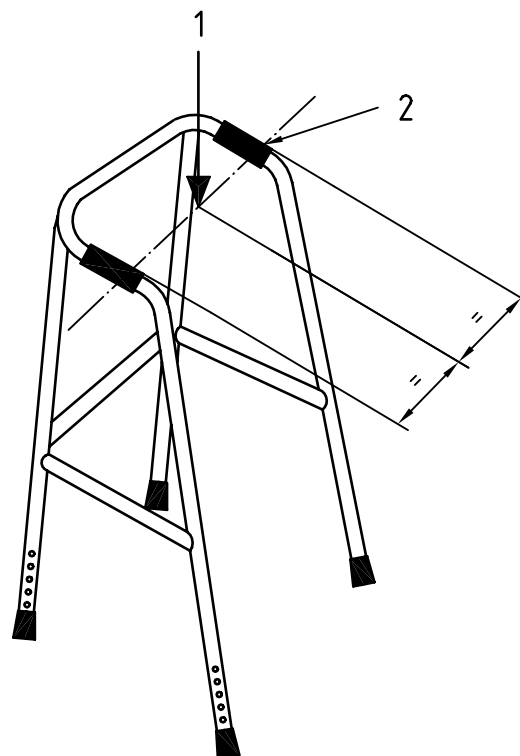

Key

- 1 Load
- 2 Rear handgrip reference point

Figure 4 — Loading geometry for fatigue and static loading tests

5.4.3 Loading time

The loading force shall be gradually applied over a minimum period of 2 s up to maximum force. This maximum force shall be applied for a minimum of 5 s.

5.5 Static leg-strength test

5.5.1 Loading geometry

A loading force shall be applied in turn to each of the legs of the walking frame. The loading force shall be applied at right angles to the leg at a point 10 mm further out than the lower end of the leg, and directed towards the centre of the frame. This is achieved by removing the rubber tip and inserting a tightly fitting plug up to a maximum of 100 mm into the tubing comprising the lower part of the leg. This plug shall protrude more than 10 mm outside the leg, in order to receive the loading force.

The height adjustment of the frame shall be at maximum. The leg being tested shall be supported as near the lower brace as possible on the handgrip side of the brace, and at a point near the top of the frame (see Figure 5).

5.5.2 Loading force

The loading force shall be 300 N ± 2 %.

NOTE See also A.2.1.

5.5.3 Loading time

The loading force shall be gradually applied over a minimum period of 2 s up to maximum force. This maximum force shall be applied for a minimum of 5 s.

Dimensions in millimetres

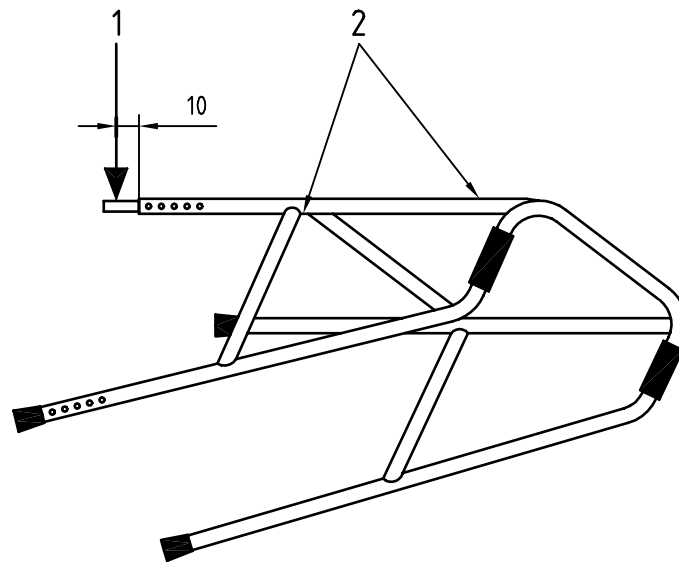

Key

- 1 Load
- 2 Supports

Figure 5 — Loading geometry for static strength tests

5.6 Forward stability test

5.6.1 Loading geometry

Height adjustment and handles shall be positioned as specified in 5.1. Reciprocating frames shall be in their most stable position.

The frame shall be placed with its tips on a plane which can be tilted from the horizontal with the centreline of the hinges parallel to the line joining the tips of the front legs, and at right angles to the normal direction of movement when the walking frame is in use (Figure 6). The loading force shall be applied vertically to the walking frame. The loading line shall remain vertical and pass through the midpoint of the line joining the front handgrip reference points on the two handgrips.

5.6.2 Procedure

A static force of $250 \text{ N} \pm 2 \%$ shall be applied. The plane is tilted and the maximum angle of the plane at the point of walking frame tilting is recorded and rounded down to the nearest $0,1^\circ$.

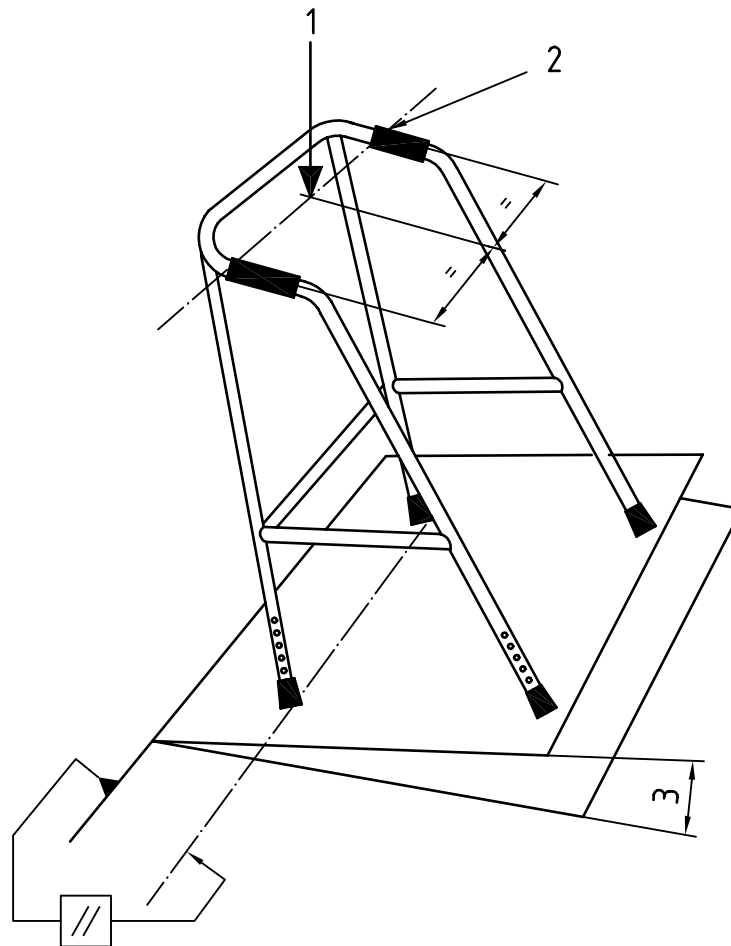

Key

- 1 Load
- 2 Front handgrip reference point
- 3 Tilt angle

Figure 6 — Loading geometry for forwards stability

5.7 Backward stability test

5.7.1 Loading geometry

Height adjustment and handles shall be positioned as specified in 5.1. Reciprocating frames shall be in their most stable position.

The frame shall be placed with its tips on a plane which can be tilted from the horizontal, with the centreline of the hinges parallel to the line joining the tips of the rear legs, and at right angles to the normal direction of movement when the walking frame is in use (Figure 7). The loading force shall be applied vertically to the walking frame. The loading line shall remain vertical and pass through the midpoint of the line joining the rear handgrip reference points on the two handgrips.

5.7.2 Procedure

A static force of $250\text{ N} \pm 2\%$ shall be applied. The plane is tilted and the maximum angle of the plane at the point of walking frame tilting is recorded and rounded down to the nearest $0,1^\circ$.

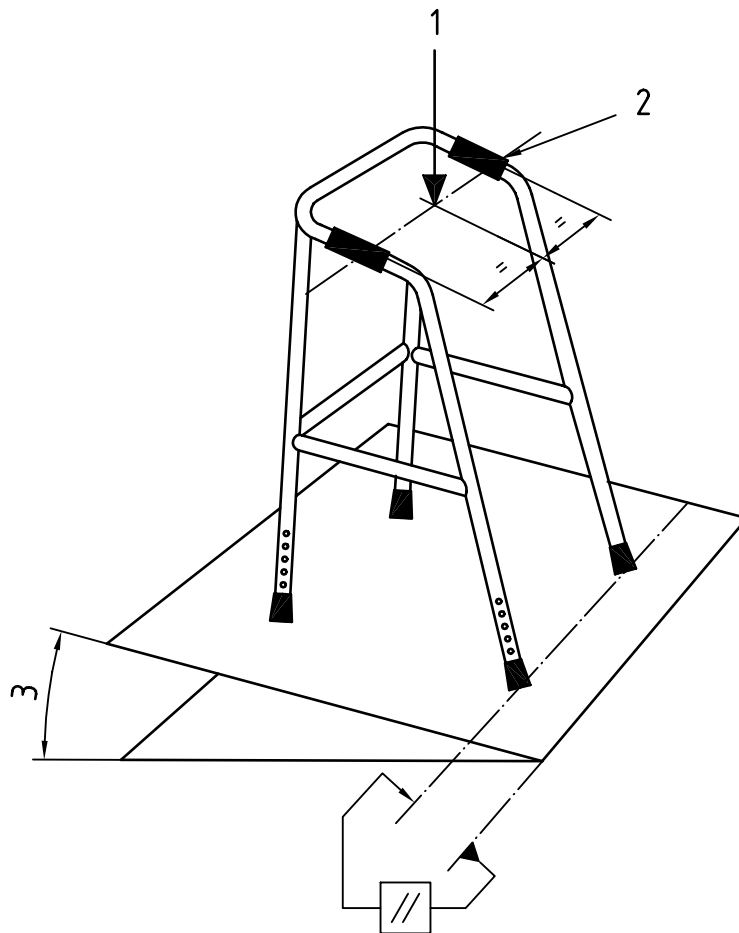

Key

- 1 Load
- 2 Rear handgrip reference point
- 3 Tilt angle

Figure 7 — Loading geometry for backward stability

5.8 Sideways stability test

5.8.1 Loading geometry

Height adjustment and handles shall be positioned as specified in 5.1. Reciprocating frames shall be in their most stable position.

The frame shall be placed with its tips on a plane which can be tilted from the horizontal with the centreline of the hinges parallel to the line joining the tips of the front and rear legs on the same side of the walking frame as is the loaded handgrip (Figure 8). The loading force shall be applied vertically to the walking frame through a point halfway between the front and the rear reference points of that handgrip nearest to the hinges of the tilting plane.

5.8.2 Procedure

A static force of $250 \text{ N} \pm 2 \%$ shall be applied. The plane is tilted and the maximum angle of the plane at the point of walking frame tilting is recorded to $\pm 0,1^\circ$. Both handgrips shall be tested in this manner and the lower value found shall be rounded down to the nearest $0,1^\circ$ and recorded.

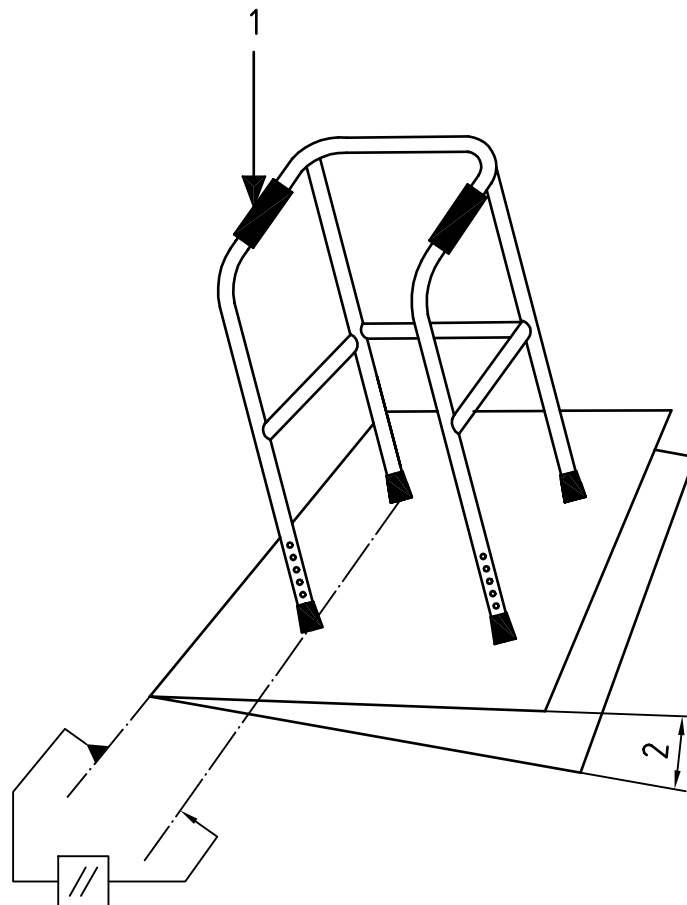

Key

- 1 Load
- 2 Tilt angle

Figure 8 — Loading geometry for sideways stability

6 Marking and labelling

Each walking frame shall be clearly and indelibly marked with the following information:

- a) maximum user weight;
- b) maximum allowed angle between the longitudinal centreline of the handle and the direction of motion, if the handles are sideways adjustable;
- c) manufacturer's name or tradename and address;
- d) manufacturer's model identification name and/or number;
- e) month and year of manufacture;
- f) maximum extension of the height adjustment, marked on the adjusting members.

7 Test report

The test report shall contain the following information:

- a) name and address of the manufacturer;
- b) name and address of the supplier;
- c) name and address of the testing institution;
- d) classification code and name in accordance with ISO 9999;
- e) maximum user weight;
- f) maximum allowed angle between the longitudinal centreline of the handle and the direction of motion, if handles are sideways adjustable;
- g) manufacturer's type and model identification name and/or number;
- h) supplier's type and model identification name and/or number;
- i) photograph of the walking frame;
- j) month and year when the test was performed;
- k) whether or not the product complies with the requirements of this part of ISO 11199;
- l) diameter of that part of the tip which is in contact with the walking surface.

Annex A (informative)

Recommendations

A.1 Scope

This annex gives supplementary information and guidance on details which also should be taken into account in the design, manufacture and testing of walking frames.

A.2 Recommendations

A.2.1 Mechanical durability

When tested according to the tests specified in 5.3 or 5.4, the walking frame should not show any deformation resulting in a permanent set such as to impair the use of the frame or adjusting mechanism(s).

When tested as specified in 5.5, a loading force of $500\text{ N} \pm 2\%$ is recommended to provide a safety factor for reasonably foreseeable misuse.

A.2.2 Stability

When tested according to the forward stability test (5.6), the angle of the plane at the point of walking frame tilting should be not less than $15,0^\circ$.

When tested according to the sideways stability test (5.8), the angle of the plane at the point of walking frame tilting should be not less than $6,0^\circ$.

A.2.3 Handle and handgrip

The handle may be adjustable but should be securely fixed when in use.

The shape and/or the material of the handgrip should prevent the hand from sliding when gripped.

The material of the handgrip should be non-absorbent.

A.2.4 Leg section and tip

The tip should be pliable, hard-wearing and have a high coefficient of friction against the walking surface.

The tip tread against the walking surface should be such that any "suction cup" effect is avoided.

The tip should be secure when fitted.

A.2.5 Adjustment and folding devices

It should be possible to operate the adjustment and folding devices without the use of tools.

A.2.6 Materials and finish

The walking frame should not rattle when in use.

For cleaning purposes, the materials and surface treatments used should withstand ordinary alkaline domestic cleaning detergents or spirits, and be easy to dry. After such cleaning agents have been used, corrosion or ageing of the materials should not accelerate.

A.2.7 Light-reflecting material

Light reflecting material should be mounted as close as possible to the vertical, as close as possible to right angles to the line of travel, as low as possible on the walking frame and not higher than 800 mm above the walking surface.

A.3 Marking and labelling

Each walking frame should, in addition to the requirements given in clause 6, be marked with the following:

- a) the walking frame size, in accordance with Table A.1;
- b) the supplier's name;
- c) the supplier's model identification name and/or number.

Table

A.1

Frame size (related to max. walking frame height)	Frame height max. mm	User height mm	
		min.	max.
1	900	350	550
2	1100	450	650
3	1300	550	750
4	1550	650	850
5	1800	750	950
6	2050	850	1100

NOTE The table refers to Figure 3. A walking frame may encompass more than one frame size.

A.4 Test report

The test report should, in addition to the requirements given in clause 7, contain an annex with the following information:

- a) inspection report as specified in 5.2;
- b) results of test described in 5.3;
- c) results of test described in 5.4;
- d) results of test described in 5.5;
- e) results of test described in 5.6;

- f) results of test described in 5.7;
- g) results of test described in 5.8;
- h) maximum walking frame height;
- i) minimum walking frame height;
- j) maximum walking frame width;
- k) maximum walking frame length;
- l) maximum walking frame turning diameter;
- m) width between the centrelines of the handgrips measured at the midpoint of the handgrips;
- n) walking frame handgrip width;
- o) folded walking frame dimensions;
- p) mass of the walking frame without accessories;
- q) whether or not tools are necessary to operate the adjustment and folding devices;
- r) any other relevant information.

www.iso.org

ICS 11.180

Price based on 15 pages
