

INTERNATIONAL
STANDARD

ISO
11197

Third edition
2016-02-15

Medical supply units

Gaines techniques à usage médical



Reference number
ISO 11197:2016(E)

© ISO 2016



COPYRIGHT PROTECTED DOCUMENT

© ISO 2016, Published in Switzerland

All rights reserved. Unless otherwise specified, no part of this publication may be reproduced or utilized otherwise in any form or by any means, electronic or mechanical, including photocopying, or posting on the internet or an intranet, without prior written permission. Permission can be requested from either ISO at the address below or ISO's member body in the country of the requester.

ISO copyright office
Ch. de Blandonnet 8 • CP 401
CH-1214 Vernier, Geneva, Switzerland
Tel. +41 22 749 01 11
Fax +41 22 749 09 47
copyright@iso.org
www.iso.org

Contents

Foreword	v
Introduction.....	viii
201.1 Scope,object and related standards	1
201.1.1 Scope.....	1
201.1.2 Object.....	1
201.1.3 Related standards.....	1
201.1.3.1 Collateral standards.....	1
201.1.3.2 Particular standards	2
201.2 Normative references	2
201.3 Terms and definitions	4
201.4 General requirements	5
201.5 General requirements for testing ME EQUIPMENT	5
201.6 Classification of ME EQUIPMENT and ME SYSTEMS	5
201.7 ME EQUIPMENT identification, marking and documents.....	5
201.8 Protection against electrical HAZARDS from ME EQUIPMENT	9
201.9 Protection against mechanical HAZARDS of ME EQUIPMENT and ME SYSTEMS.....	15
201.10 Protection against unwanted and excessive radiation HAZARDS	17
201.11 Protection against excessive temperatures and other HAZARDS	17
201.12 Accuracy of controls and instruments and protection against hazardous outputs.....	17
201.13 HAZARDOUS SITUATIONS and fault conditions	17
201.14 PROGRAMMABLE ELECTRICAL MEDICAL SYSTEMS (PEMS)	18
201.15 Construction of ME EQUIPMENT	18
201.16 ME SYSTEMS	23
201.17 Electromagnetic compatibility of ME EQUIPMENT and ME SYSTEMS.....	23
202 MEDICAL ELECTRICAL EQUIPMENT - part 1-2 General requirements for BASIC SAFETY and ESSENTIAL PERFORMANCE – Collateral standard: Electromagnetic disturbances – Requirements and tests	23
206 MEDICAL ELECTRICAL EQUIPMENT - part 1-6 General requirements for BASIC SAFETY and ESSENTIAL PERFORMANCE – Collateral standard: Usability.....	23
Annex AA (informative) Rationale	24
Bibliography	25

Foreword

ISO (the International Organization for Standardization) is a worldwide federation of national standards bodies (ISO member bodies). The work of preparing International Standards is normally carried out through ISO technical committees. Each member body interested in a subject for which a technical committee has been established has the right to be represented on that committee. International organizations, governmental and non-governmental, in liaison with ISO, also take part in the work. ISO collaborates closely with the International Electrotechnical Commission (IEC) on all matters of electrotechnical standardization.

The procedures used to develop this document and those intended for its further maintenance are described in the ISO/IEC Directives, Part 1. In particular the different approval criteria needed for the different types of ISO documents should be noted. This document was drafted in accordance with the editorial rules of the ISO/IEC Directives, Part 2. www.iso.org/directives

Attention is drawn to the possibility that some of the elements of this document may be the subject of patent rights. ISO shall not be held responsible for identifying any or all such patent rights. Details of any patent rights identified during the development of the document will be in the Introduction and/or on the ISO list of patent declarations received. www.iso.org/patents

Any trade name used in this document is information given for the convenience of users and does not constitute an endorsement.

For an explanation on the meaning of ISO specific terms and expressions related to conformity assessment, as well as information about ISO's adherence to the WTO principles in the Technical Barriers to Trade (TBT) see the following URL: [Foreword - Supplementary information](#)

The committee responsible for this document is ISO/TC 121.

ISO 11197 was prepared by the European Committee for Standardization (CEN) Technical Committee CEN/TC 215, *Respiratory and anaesthetic equipment*, in collaboration with ISO Technical Committee TC 121, *Anaesthetic and respiratory equipment*, Subcommittee SC 6, *Medical gas systems*, in accordance with the Agreement on technical cooperation between ISO and CEN (Vienna Agreement).

This third edition cancels and replaces the second edition (ISO 11197:2004), which has been technically revised.

Introduction

Many healthcare facilities use surface-mounted or recessed containment systems and ENCLOSURES for accommodating and displaying essential PATIENT care services. These are known as MEDICAL SUPPLY UNITS.

This International Standard specifies requirements for MEDICAL SUPPLY UNITS manufactured in factories or assembled from components on site.

It is intended for use by those persons involved in the design, construction, inspection, testing, maintenance and operation of healthcare facilities as well as those manufacturing, assembling and installing MEDICAL SUPPLY UNITS.

Persons involved in the design, manufacture, installation, maintenance and testing of equipment intended to be connected to MEDICAL GAS, vacuum, ANAESTHETIC GAS SCAVENGING and/or PLUME EXTRACTION SYSTEMS should be aware of the contents of this document.

This International Standard is a particular standard, based on IEC 60601-1:2005+A1:2012. IEC 60601-1:2005+A1:2012 is the basic standard for the safety of all MEDICAL ELECTRICAL EQUIPMENT used by or under the supervision of qualified personnel in the general medical and PATIENT environment; it also contains certain requirements for reliable operation to ensure safety.

IEC 60601-1:2005+A1:2012 has associated collateral standards and particular standards. The collateral standards include requirements for specific technologies and/or HAZARDS and apply to all applicable equipment, such as medical systems, EMC, radiation protection in diagnostic X-ray equipment, software, etc. The particular standards apply to specific equipment types, such as medical electron accelerators, high frequency surgical equipment, hospital beds, etc.

NOTE Definitions of collateral standard and particular standard can be found in IEC 60601:2005+A1:2012.

For an explanation of the special numbering in this document and more on the terms “collateral”, “particular” and “general” standards, see 201.1.3, 201.1.4, and 201.1.5.

Annex AA contains rationale statements for some of the requirements of this International Standard. It is included to provide additional insight into the reasoning that led to the requirements and recommendations that have been incorporated in this International Standard. The clauses and subclauses marked with (*) after their number have a corresponding rationale contained in Annex AA.

Medical supply units

201.1 Scope, object and related standards

IEC 60601-1:2005+A1:2012, Clause 1 applies except as follows:

201.1.1 Scope

IEC 60601-1:2005+A1:2012, 1.1 is replaced by:

This International Standard applies to the BASIC SAFETY and ESSENTIAL PERFORMANCE of MEDICAL SUPPLY UNITS, hereafter also referred to as ME EQUIPMENT.

This International Standard applies to MEDICAL SUPPLY UNITS manufactured within a factory or assembled on site, including cabinetry and other ENCLOSURES, which incorporate PATIENT care services.

NOTE 1 A party that assembles on site various components intended for PATIENT care services into an ENCLOSURE is considered the MANUFACTURER of the MEDICAL SUPPLY UNIT.

HAZARDS inherent in the intended function of ME EQUIPMENT or ME SYSTEMS within the scope of this International Standard are not covered by specific requirements in this standard except in 7.2.13 and 8.4.1 of IEC 60601-1:2005+A1:2012 (see 201.1.4).

NOTE 2 See also IEC 60601-1:2005+A1:2012, 4.2.

201.1.2 Object

IEC 60601-1:2005+A1:2012, 1.2 is replaced by:

The object of this International Standard is to establish particular BASIC SAFETY and ESSENTIAL PERFORMANCE requirements for MEDICAL SUPPLY UNITS as defined in 201.3.103.

201.1.3 Related standards

201.1.3.1 Collateral standards

IEC 60601-1:2005+A1:2012, 1.3 applies with the following addition:

This particular standard refers to those applicable collateral standards that are listed in IEC 60601-1:2005+A1:2012, Clause 2 as well as 201.2 of this particular standard.

ISO 11197:2016(E)

IEC 60601-1-3:2008, IEC 60601-1-8:2006+A1:2012, IEC 60601-1-9:2007, and IEC 60601-1-10:2007+A1:2013 do not apply.

NOTE Collateral standards are referred to by their document numbers.

201.1.3.2 Particular standards

IEC 60601-1:2005+A1:2012, 1.4 applies with the following additions:

The numbering of sections, clauses and subclauses of this particular standard corresponds to that of IEC 60601-1:2005+A1:2012 with the prefix “201” (e.g. 201.1 in this standard addresses the content of IEC 60601-1:2005+A1:2012 Clause 1) or applicable collateral standard with the prefix “20x” where x is the final digit(s) of the collateral standard document number (e.g. 202.4 in this particular standard addresses the content of Clause 4 of the IEC 60601-1-2 collateral standard, 203.4 in this particular standard addresses the content of Clause 4 of the IEC 60601-1-3 collateral standard, etc.). The changes to the text of IEC 60601-1:2005+A1:2012 are specified by the use of the following words:

- “Replacement” means that the clause or subclause of IEC 60601-1:2005+A1:2012 or applicable collateral standard is replaced completely by the text of this particular standard.
- “Addition” means that the text of this particular standard is additional to the requirements of IEC 60601-1:2005+A1:2012 or applicable collateral standard.
- “Amendment” means that the clause or subclause of IEC 60601-1:2005+A1:2012 or applicable collateral standard is amended as indicated by the text of this particular standard.

Subclauses or figures which are additional to those of IEC 60601-1:2005+A1:2012 are numbered starting from 201.101. Additional Annexes are lettered AA, BB, etc., and additional items aa), bb), etc.

Subclauses or figures which are additional to those of a collateral standard are numbered starting from 20x, where “x” is the number of the collateral standard, e.g. 202 for IEC 60601-1-2, 203 for IEC 60601-1-3, etc.

The term “this standard” is used to make reference to IEC 60601-1:2005+A1:2012, any applicable collateral standards and this particular standard taken together.

Where there is no corresponding section, clause or subclause in this particular standard, the section, clause or subclause of IEC 60601-1:2005+A1:2012 or applicable collateral standard, although possibly not relevant, applies without modification; where it is intended that any part of IEC 60601-1:2005+A1:2012 or applicable collateral standard, although possibly relevant, is not to be applied, a statement to that effect is given in this particular standard.

201.2 Normative references

The following documents, in whole or in part, are normatively referenced in this document and are indispensable for its application. For dated references, only the edition cited applies. For undated references, the latest edition of the referenced document (including any amendments) applies.

NOTE Informative references are listed in the Bibliography on page 25.

IEC 60601-1:2005+A1:2012, Clause 2 applies and IEC 60601-1-2:2014, Clause 2 applies, with the following additions:

IEC 60364-5-54:2011, Electrical installations of buildings — Part 5-54: Selection and erection of electrical equipment; Earthing arrangements, protective conductors and protective bonding conductors

IEC 60364-7-710:2002, *Electrical installations of buildings — Part 7-710: Requirements for special installations or locations; Medical locations*

IEC 60529:1989+AMD1:1999 +AMD2:2013 CSV/COR2:2015, *Degrees of protection provided by enclosures (IP Code)*

IEC 60598-1:2014, *Luminaires — Part 1: General requirements and tests*

IEC 60601-1:2005+A1:2012, *Medical electrical equipment — Part 1: General requirements for basic safety and essential performance*

IEC 60601-1-2:2014 *Medical electrical equipment — Part 1-2: General requirements for basic safety and essential performance – Collateral standard: Electromagnetic compatibility – Requirements and tests*

IEC 60601-1-3:2008, *Medical electrical equipment — Part 1: General requirements for safety 3. Collateral Standard: General Requirements for Radiation Protection in Diagnostic X-Ray Equipment*

IEC 60601-1-6:2010, *Medical electrical equipment — Part 1-6: General requirements for basic safety and essential performance — Collateral standard: Usability*

IEC 60601-1-8:2006+A1:2012, *Medical electrical equipment — Part 1-8: General requirements for basic safety and essential performance — Collateral Standard: General requirements, test and guidance for alarm systems in medical electrical equipment and medical electrical systems*

IEC 60601-1-9:2007, *Medical electrical equipment — Part 1-9: General requirements for basic safety and essential performance — Collateral Standard: Requirements for environmentally conscious design*

IEC 60601-1-10:2007, *Medical electrical equipment — Part 1-10: General requirements for basic safety and essential performance — Collateral Standard: Requirements for the development of physiologic closed-loop controllers*

IEC 61386-1:2008, *Conduit systems for cable management — Part 1: General requirements*

IEC 61950:2007, *Cable management systems — Specifications for conduit fittings and accessories for cable installations for extra-heavy duty electrical steel conduit*

ISO 3744:2010, *Acoustics — Determination of sound power levels and sound energy levels of noise sources using sound pressure — Engineering methods for an essentially free field over a reflecting plane*

ISO 5359:2014, *Anaesthetic and respiratory equipment — Low-pressure hose assemblies for use with medical gases*

ISO 7396-1:2007, *Medical gas pipeline systems — Part 1: Pipeline systems for compressed medical gases and vacuum*

ISO 7396-2:2007, *Medical gas pipeline systems — Part 2: Anaesthetic gas scavenging disposal systems*

ISO 9170-1:2008, *Terminal units for medical gas pipeline systems — Part 1: Terminal units for use with compressed medical gases and vacuum*

ISO 9170-2:2008, *Terminal units for medical gas pipeline systems — Part 2: Terminal units for anaesthetic gas scavenging systems*

ISO 14971:2007, *Medical devices — Application of risk management to medical devices*

ISO 16571:2014, *Systems for evacuation of plume generated by medical devices*

EN 50174-1:2009 + A2:2014, *Information technology. Cabling installation — Part 1: Installation specification and quality assurance*

EN 50174-2:2009+ A2:2014, *Information technology. Cabling installation — Part 2: Installation planning and practices inside buildings*

201.3 Terms and definitions

For the purpose of this document, the terms and definitions given in IEC 60601-1:2005+A1:2012, ISO 16571:2014, ISO 7396-1:2007 and the following apply.

NOTE An alphabetical index of defined terms is found at the end of this document.

Replacement of 3.26:

201.3.26

ENCLOSURE

surrounding case constructed to provide a degree of protection to personnel against accidental contact with live parts and also the enclosed equipment against specified environmental conditions

Note 1 to entry: See IEC 61950:2007, 3.15.

Note 2 to entry: An ENCLOSURE can be subdivided into COMPARTMENTS.

Addition:

201.3.101

COMPARTMENT

part of an ENCLOSURE with openings necessary for interconnection, control or ventilation

201.3.102

JUNCTION POINT

connection point(s) between the MEDICAL SUPPLY UNIT and the system(s) already installed

201.3.103

MEDICAL SUPPLY UNIT

permanently installed ME EQUIPMENT intended to supply electric power, communication means (telephone, call systems, etc.), data transmission, lighting, and/or MEDICAL GASES and/or liquids, an ANAESTHETIC GAS SCAVENGING SYSTEM and/or a PLUME EVACUATION SYSTEM to medical areas of a healthcare facility

Note 1 to entry: MEDICAL SUPPLY UNITS can include ME EQUIPMENT or ME SYSTEMS or parts thereof. MEDICAL SUPPLY UNITS can also consist of modular sections for electrical supply, lighting for therapy or illumination, communication, supply of MEDICAL GASES and liquids, PLUME EVACUATION SYSTEMS and ANAESTHETIC GAS SCAVENGING SYSTEMS. Some typical examples of MEDICAL SUPPLY UNITS are bed head service modules, ceiling pendants, beams, booms, columns, pillars, cabinetry, concealed COMPARTMENTS on or in a wall and prefabricated walls.

Note 2 to entry: Examples of configurations are given in Figures 201.103, 201.104 and 201.105.

201.3.104**PLUME EVACUATION SYSTEM****PES**

device for capturing, transporting, and filtering plume and exhausting the filtered product

Note 1 to entry: PLUME EVACUATION SYSTEMS can also be called smoke evacuators, laser plume evacuators, plume scavengers, and local exhaust ventilators (LEVs).

201.4 General requirements

IEC 60601-1:2005+A1:2012, Clause 4 applies.

201.5 General requirements for testing ME EQUIPMENT

IEC 60601-1:2005+A1:2012, Clause 5 applies with the following additions:

201.5.9.2.3 Actuating mechanisms

All external surfaces shall conform to a degree of protection against direct contact in normal operation of at least IP2X or IPXXB. See IEC 60529:1989+AMD1:1999+AMD2:2013 CSV/COR2:2015.

This level of protection to live parts shall not be compromised during maintenance of the MEDICAL GAS PIPELINE SYSTEMS, ANAESTHETIC GAS SCAVENGING SYSTEMS, PLUME EVACUATION SYSTEMS or liquid pipeline systems, e.g. by the provision of covers, barriers or individual protection with a degree of protection of at least IP2X or IPXXB. See IEC 60529:1989+AMD1:1999+AMD2:2013 CSV/COR2:2015.

If requested by the healthcare facility (e.g. in psychiatric or paediatric units or prison healthcare facilities), the MANUFACTURER shall provide means to prevent inadvertent or unauthorized dismantling of MEDICAL SUPPLY UNITS.

201.5.101 MEDICAL SUPPLY UNIT test results

The MANUFACTURER shall test each MEDICAL SUPPLY UNIT. The test results shall be recorded and presented to the RESPONSIBLE ORGANIZATION on request.

201.6 Classification of ME EQUIPMENT and ME SYSTEMS

IEC 60601-1:2005+A1:2012, Clause 6 applies, with the following additions:

201.6.1 Protection against electric shock

A MEDICAL SUPPLY UNIT shall be designed and constructed as CLASS I and fulfil the requirements of a TYPE B APPLIED PART according to the degree of protection against electric shock.

201.7 ME EQUIPMENT identification, marking and documents

IEC 60601-1:2005+A1:2012, Clause 7 applies, with the following additions:

201.7.2.1 Minimum requirements for marking on ME EQUIPMENT and on interchangeable parts

Mains-operated equipment, including separable components thereof which have a MAINS PART, shall be provided with permanent and legible marking on the outside of the major part of the equipment indicating the origin and model or type reference.

Terminal units

- Terminal units for MEDICAL GASES and vacuum shall be marked in accordance with ISO 9170-1:2008 or national regulations. Colour coding, if used, shall be in accordance with ISO 9170-1:2008 or national regulations.
- Terminal units for ANAESTHETIC GAS SCAVENGING SYSTEMS shall be marked in accordance with ISO 9170-2:2008 or national regulations. Colour coding, if used, shall be in accordance with ISO 9170-2:2008 or national regulations.
- Terminal units for liquids shall be marked with the name of the liquid in accordance with Table 201.101 or the equivalent national language.
- Terminal units for plume evacuation shall be marked in accordance with ISO 16571:2014.

NOTE Regional or national regulations which apply to ME EQUIPMENT identification, marking and documents can exist.

Table 201.101 — Marking for liquids

Name of liquid
Potable water, cold
Potable water, warm
Cooling water
Cooling water, feed-back
De-mineralized water
Distilled water
Dialysing concentrate
Dialysing permeate

201.7.2.6 Connection to the SUPPLY MAINS

Due to the possible complexity of external marking, diagrams indicating all electrical and electronic connections to the MEDICAL SUPPLY UNIT shall be located at the JUNCTION POINT inside the equipment.

For electrical connections the diagram shall indicate voltages, number of phases and number of circuits. For electronic connections, the diagram shall indicate connector numbers and wire identification.

201.7.2.8 Output connectors

201.7.2.8.1 Mains power output

Mains socket-outlets for special purposes (e.g. for x-ray equipment) shall be marked with the type of mains, rated voltage, rated current and with a label (e.g. "X-RAY").

When a MEDICAL SUPPLY UNIT is provided with socket-outlets for connection to an essential electrical supply circuit (e.g. uninterruptible power supply (UPS), a Medical IT system as defined in IEC 60364-7-710:2002), these socket-outlets shall comply with the national installation rules or be individually identified if not covered by those rules.

If socket-outlets in the same location are supplied from different power sources, each source should be readily identifiable.

NOTE Regional or national regulations can apply to the mains power outlet configurations.

201.7.2.19 Functional earth terminals

Facilities for the connection of supplementary equipotential earth bonding (if provided) shall be marked with symbol 8 of Annex D, Table D 1 of IEC 60601-1:2005+A1:2012.

201.7.3 Marking on the outside of ME EQUIPMENT or ME EQUIPMENT parts

JUNCTION POINTS and pipelines for MEDICAL GASES shall be marked in accordance with ISO 7396-1:2007 or national regulations. Colour coding, if used, shall be in accordance with ISO 7396-1:2007 or national regulations.

JUNCTION POINTS and pipelines for ANAESTHETIC GAS SCAVENGING SYSTEMS shall be marked in accordance with ISO 7396-2:2007 or national regulations. Colour coding, if used, shall be in accordance with ISO 7396-2:2007 or national regulations.

JUNCTION POINTS and pipelines for liquids shall be marked with the name of the liquid in accordance with Table 201.101 or the equivalent in national language.

JUNCTION POINTS and pipelines for plume evacuation shall be marked in accordance with ISO 16571:2014.

If the MEDICAL SUPPLY UNIT has a terminal connecting the neutral line of the power supply, it shall be clearly identified using the sign A of IEC 60601-1:2005+A1:2012, Annex D.3, the letter N and/or be colour coded blue or be colour coded in accordance with national regulations.

201.7.9 ACCOMPANYING DOCUMENTS

201.7.9.1 General

Replace the first dash in IEC 60601-1:2005+A1:2012 7.9.1 with the following:

The ACCOMPANYING DOCUMENTS shall include the following:

- the name or trade name and address of the MANUFACTURER and the authorized representative where the MANUFACTURER does not have a registered place of business within the locale;
- a declaration by the MANUFACTURER or on-site MANUFACTURER of compliance with this standard.

201.7.9.2 Instructions for use and maintenance

201.7.9.2.1 General

The instructions for use shall contain the date of issue or the latest revision of the instructions for use.

201.7.9.2.16 Reference to the technical description

General information

- Instructions for use shall state which parts of the equipment are capable of bearing additional loads. The maximum SAFE WORKING LOAD shall be stated.
- If flexible hoses and hose assemblies are used for supplying MEDICAL GASES, ANAESTHETIC GAS SCAVENGING SYSTEMS, PLUME EVACUATION SYSTEMS or liquids in an OPERATOR-adjustable system (e.g. a ceiling pendant), the instructions for use shall include a PROCEDURE for, and the recommended frequency of, inspection and replacement.

Responsibility of the MANUFACTURER

- The MANUFACTURER shall document the manufacturing tests that have been performed on each MEDICAL SUPPLY UNIT to demonstrate that the requirements of this standard have been met. This documentation shall be retained and made available upon request.

Specifications for installation, use and maintenance

- MEDICAL SUPPLY UNITS shall be installed, tested and used in compliance with ISO 7396-1:2007 and ISO 7396-2:2007 and the MANUFACTURER'S instructions.

NOTE See IEC 60364-7-710:2002 for information on this subject.

It is recommended that consideration be given to the mounting height of MEDICAL SUPPLY UNITS in order to satisfy user requirements for illumination, viewed luminance and access to services.

201.7.9.3 Technical description

a) If flexible hoses are used for supplying MEDICAL GASES in an OPERATOR-adjustable system (e.g. a ceiling pendant), the instructions for use shall state that the following tests given in ISO 7396-1:2007 shall be carried out following modification or replacement of the flexible hose:

- test for leakage,
- test for obstruction,
- test for particulate contamination,
- test of flow and pressure drop,
- test for cross connection,
- test of gas identity.

b) If flexible hoses are used for supplying anaesthetic gas scavenging in an OPERATOR-adjustable system (e.g. a ceiling pendant), the instructions for use shall state that the following tests given in ISO 7396-2:2007 shall be carried out following modification or replacement of the flexible hose:

- test for leakage,
- test of flow and pressure drop.

c) If flexible hoses are used for supplying liquids in an OPERATOR-adjustable system (e.g. a ceiling pendant), the instructions for use shall state that the following test shall be carried out following modification or replacement of the flexible hose:

- test for leakage.

Compliance shall be checked by functional testing.

- test for cross connections between pipelines for different liquids.

Compliance shall be checked by functional testing.

d) If flexible hoses are used for supplying plume evacuation in an OPERATOR-adjustable system (e.g. a ceiling pendant), the instructions for use shall state the following test, given in ISO 16571:2014, shall be carried out following modification or replacement of the flexible hose:

- test for leakage.

201.8 Protection against electrical HAZARDS from ME EQUIPMENT

IEC 60601-1:2005+A1:2012, Clause 8 applies, with the following additions:

201.8.1 Fundamental rule of protection against electric shock

Luminaires installed in or mounted on MEDICAL SUPPLY UNITS shall comply with IEC 60598-1:2014.

201.8.6 Protection earthing, functional earthing and potential equalization of ME EQUIPMENT

201.8.6.2 PROTECTIVE EARTH TERMINAL

Typical examples for the earth conductor of MEDICAL SUPPLY UNITS are shown in Figure 201.101.

Terminal units for compressed MEDICAL GASES and vacuum and for ANAESTHETIC GAS SCAVENGING SYSTEMS and PLUME EVACUATION SYSTEMS are not required to be connected to the earth terminal.

NOTE 1 ISO 7396-1:2007 requires that a MEDICAL GAS PIPELINE SYSTEM be connected to earth.

NOTE 2 Where MEDICAL SUPPLY UNITS incorporate hose assemblies, the path to earth will be broken and consideration should be given to connecting the terminal unit with metallic/electrically conductive surface to a PROTECTIVE EARTH TERMINAL or to the earthed ENCLOSURE

All earth conductors of circuits from the existing mains supply and additional equipotential earth bonding shall be individually connected in the MEDICAL SUPPLY UNIT to a common earth bar.

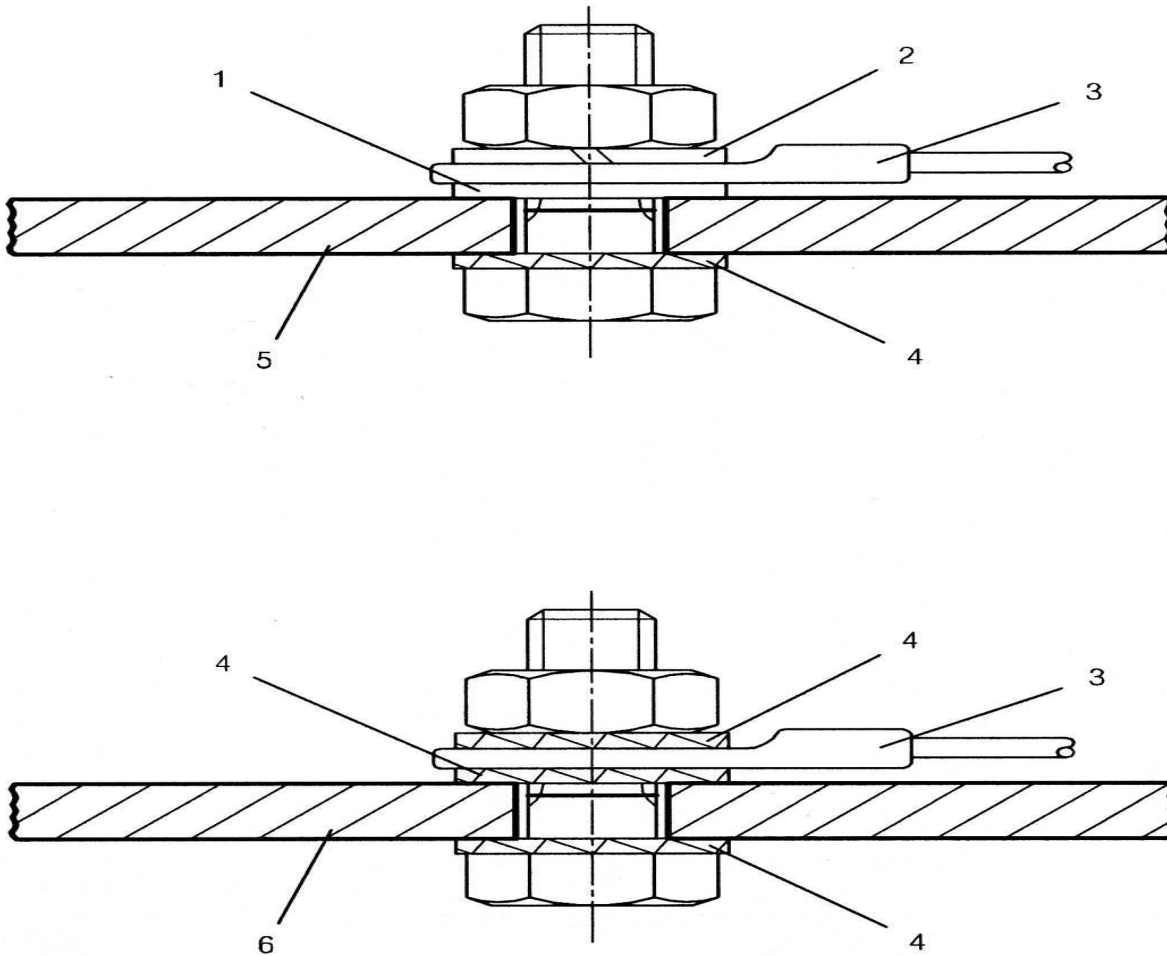

Key

- | | |
|---|--|
| 1 Cupal (Cu/Al) washer (copper surface uppermost) | 4 Lock washer |
| 2 Spring washer | 5 MEDICAL SUPPLY UNIT section (e.g. aluminium) |
| 3 Cable bracket | 6 MEDICAL SUPPLY UNIT section (e.g. ferrous) |

Figure 201.101 — Typical examples for protective measures against loosening and corrosion of potential equalization and earth-conductor facilities

201.8.6.101 Conductors

Protective earth conductors shall each have a conductance equivalent to that of the associated phase conductor with a minimum value of conductance equivalent to 2,5 mm² of copper and shall be individually connected to a common earth bar.

Equipotential earth bonding conductors for the connection of external equipment, if provided, shall each have a cross section of at least 4 mm² of copper and shall be individually detachable from the equipotential earth bonding connectors.

201.8.6.102 Bus bar

All protective earth conductors of circuits from the existing mains supply in the MEDICAL SUPPLY UNIT shall be connected to a bus bar with a conductance at least equivalent to that of 16 mm² copper.

The bus bar for protective earth conductors shall also be equipped with a terminal for connection to a protective earth conductor of at least 16 mm² cross-sectional area. Facilities for potential equalization conductors shall be connected to the bus bar of the protective earth conductor. See Figure 201.102 for an example. All terminals shall be secured against unintentional loosening. If a Medical IT power supply is used the connection of the PA-terminal and PE-terminal shall be provided.

There should be no additional potential equalization detachable bridge.

The MEDICAL GAS PIPELINE SYSTEM shall not be used as a bus bar.

NOTE 1 A metal section of the MEDICAL SUPPLY UNIT of equivalent conductance can function as a bus bar.

NOTE 2 National regulations can require different wiring configurations.

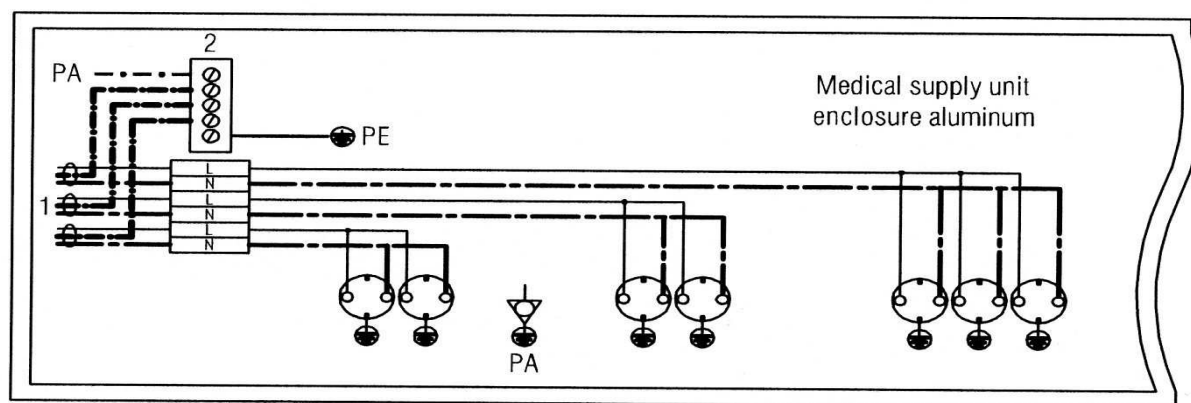

Key

- | | | | |
|---|---|----|--------------------------------|
| L | Active line | PE | Protective earth conductor |
| N | Neutral line | PA | Potential equalization sockets |
| 1 | External power supply for MEDICAL SUPPLY UNIT | | |
| 2 | Bus bar for protective earth conductor + potential equalization conductor | | |

Figure 201.102 — Example of a terminal connection of a MEDICAL SUPPLY UNIT according to IEC 60364-5-54:2011

201.8.10 Components and wiring

201.8.10.7 Insulation of internal wiring

If wiring for communication, such as a nurse call system, for radio transmission, telephone, signal for biophysical parameters, other data transmission conductors, etc. is provided in MEDICAL SUPPLY UNITS together with mains cables or pipes or flexible hoses for MEDICAL GASES, electrically safe operation under SINGLE FAULT CONDITION shall be ensured.

Conductors of different mains circuits of the same voltage do not require mechanical segregation but they should be electrically separated. A separate circuit should be provided for each haemodialysis machine and for each x-ray machine. In general inpatient bed spaces one mains circuit supplying socket-outlets can serve more than one bed. In all other departments, at least two separate mains circuit supplying socket-outlets, should be provided for each bed.

NOTE 1 Electrical separation is defined in EN 61140[3].

NOTE 2 Consideration should be given to EN 50174-2:2009+A2:2014 when power and communication cabling are contained within the same ENCLOSURE. For examples, see Figure 201.103, Figure 201.104 and Figure 201.105.

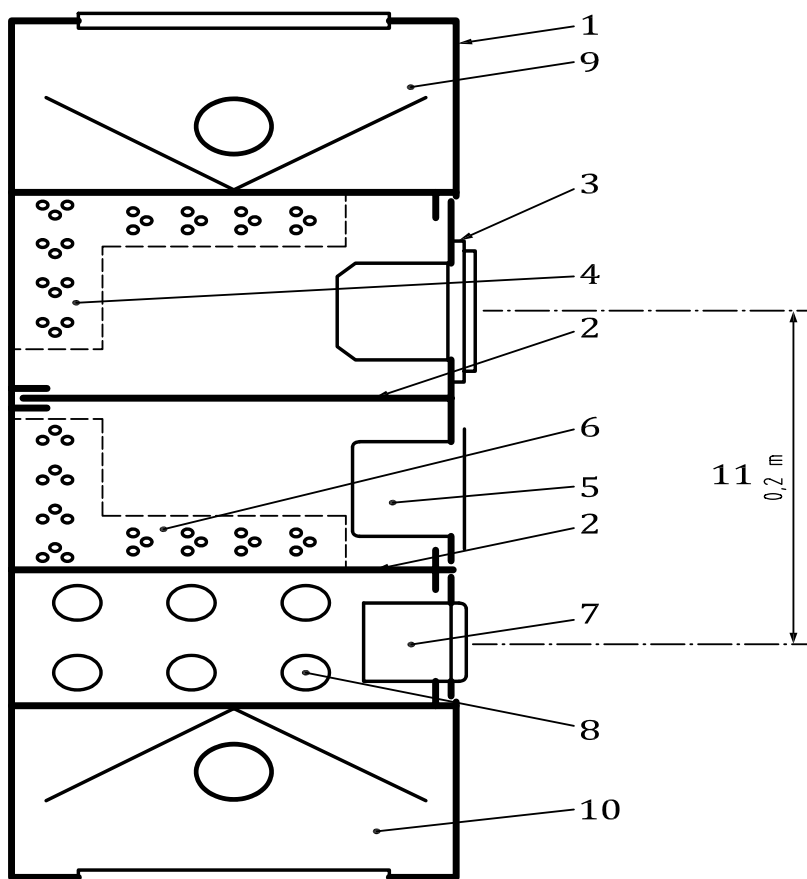

Key

- | | | | |
|---|---|----|--|
| 1 | ENCLOSURE | 7 | Gas terminal unit |
| 2 | Barrier | 8 | Gas pipes |
| 3 | Components for mains | 9 | Room light |
| 4 | Wiring mains/housing for mains wiring | 10 | Reading light |
| 5 | Components for communication purposes | 11 | Safety distance, measured on the surface to midpoint |
| 6 | Wiring communication/housing for communication wiring | | |

Figure 201.103 Sectional drawing of typical MEDICAL SUPPLY UNIT for PATIENT care rooms

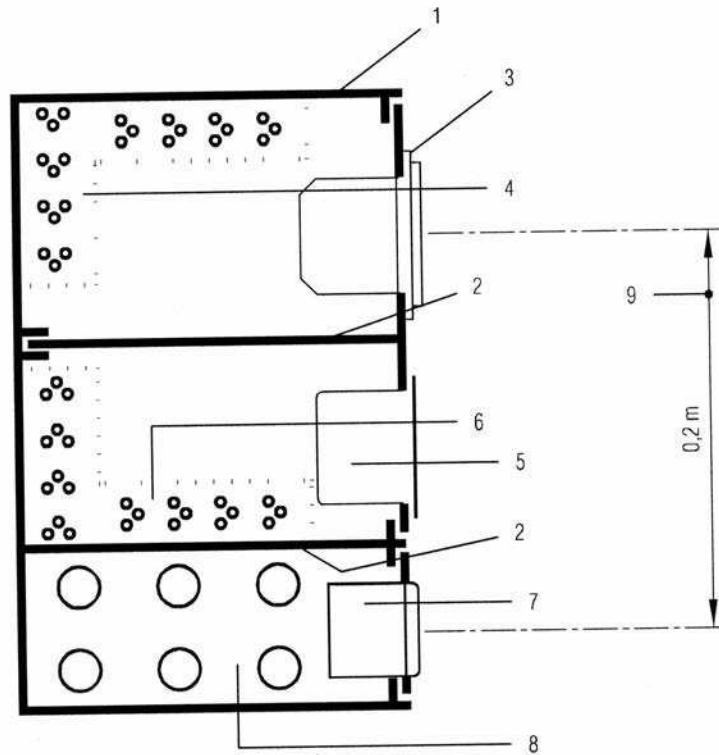

Key

- | | | | |
|---|---------------------------------------|---|---|
| 1 | ENCLOSURE | 6 | Wiring communication/housing for communication wiring |
| 2 | Barrier | 7 | Gas terminal unit |
| 3 | Components for mains | 8 | Gas pipes |
| 4 | Wiring mains/housing for mains wiring | 9 | Safety distance, measured on the surface to midpoint |
| 5 | Components for communication purposes | | |

Figure 201.104 Sectional drawing of a typical MEDICAL SUPPLY UNIT for intensive care rooms and operating theatres

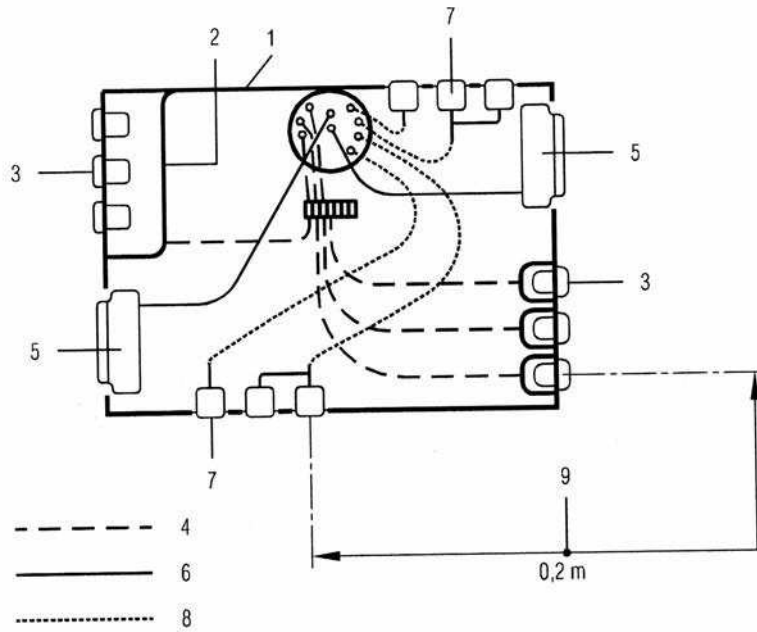

Key

- | | | | |
|---|---------------------------------------|---|---|
| 1 | ENCLOSURE | 6 | Wiring communication/housing for communication wiring |
| 2 | Barrier | 7 | Gas terminal unit |
| 3 | Components for mains | 8 | Flexible hoses |
| 4 | Wiring mains/housing for mains wiring | 9 | Safety distance, measured on the surface to midpoint |
| 5 | Components for communication purposes | | |

Figure 201.105 — Sectional drawing of typical non-rigid MEDICAL SUPPLY UNIT

The design features shall ensure that during maintenance of each piping system no live parts of the electrical system can be touched (see 201.5.9.2.3). The MANUFACTURER shall indicate on the removable safety covers to the live parts and/or in the ACCOMPANYING DOCUMENTS how safe maintenance can be ensured. See IEC 60601-1:2005+A1:2012, 8.11.1 i).

201.8.11 MAIN PARTS, components and layout

201.8.11.1 Isolation from the SUPPLY MAINS

A MEDICAL SUPPLY UNIT shall not include externally accessible master switches or fuses capable of isolating a complete electrical circuit.

The general use of switched socket-outlets is permitted, but consideration shall be given to using only unswitched socket-outlets in areas defined as containing life-supporting equipment.

If no particular circuit is designed as “essential” but socket outlets are intended to be supplied from different power sources within the same MEDICAL SUPPLY UNIT, then the circuit supplying each socket-outlet shall also be readily identifiable.

NOTE 1 Unintentional operation of mains switches or the removal of mains fuses if integrated in the MEDICAL SUPPLY UNIT could endanger the PATIENT.

NOTE 2 Regional or national regulations can apply to socket-outlet configurations.

201.9 Protection against mechanical HAZARDS of ME EQUIPMENT and ME SYSTEMS

IEC 60601-1:2005+A1:2012, Clause 9 applies, with the following additions:

201.9.1.101 Dynamic forces

MEDICAL SUPPLY UNITS shall be subjected to an impact as described in 201.9.1.102. After the impact, the live parts shall not become accessible, terminal units shall continue to meet the requirements of ISO 9170-1:2008 and existing protective devices shall remain intact.

201.9.1.102 Impact resistance test

A bag of 0,50 m width approximately half-filled with sand to give a total weight of 200 N, suspended so as to give a pendulum length of 1 m shall be released from a horizontal deflection of 0,50 m so as to hit the MEDICAL SUPPLY UNIT that is mounted according to the MANUFACTURER'S instructions. The test configuration is shown in Figure 201.106. The test shall be repeated so that at least one more part of the MEDICAL SUPPLY UNIT is impacted.

The occurrence of cracks in mouldings shall not constitute failure of the test.

201.9.1.103 Static forces

Parts of MEDICAL SUPPLY UNITS designed for additional loads shall be subjected to a test load of twice the maximum SAFE WORKING LOAD specified by the MANUFACTURER.

MEDICAL SUPPLY UNITS and their supports designed for additional loads shall not be permanently deformed or deflected by more than 10° with reference to the load-bearing surfaces.

201.9.1.104 Static load test

The test load shall be uniformly distributed over the MEDICAL SUPPLY UNIT according to the MANUFACTURER'S specifications.

201.9.1.105 Mechanical damage

Means shall be provided to allow periodic inspection in an OPERATOR-adjustable system (e.g. a ceiling pendant) to ensure that mechanical joints are free from damage (e.g. cracks and chips).

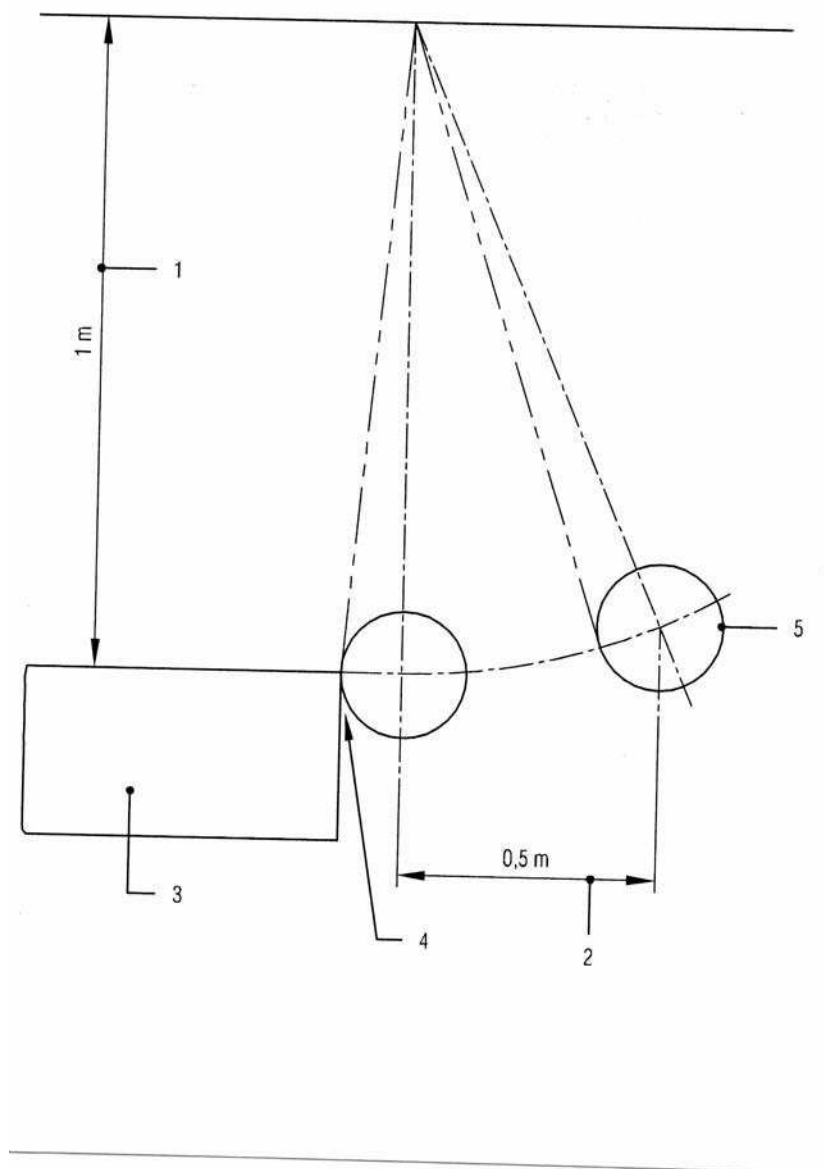

Key

- 1 Length of pendulum
- 2 Deflection
- 3 Mounted MEDICAL SUPPLY UNIT
- 4 Most vulnerable point (example)
- 5 Bag of weight 200 N

Figure 201.106 — Impact resistance test

201.9.6 Acoustic energy (including infra- and ultrasound) and vibration

201.9.6.101 Frequency spectrum

Within the frequency spectrum, individual peak noise levels shall not be in excess of 35 dB (A).

Except for noise caused by therapeutic or diagnostic measures or by adjustment of the MEDICAL SUPPLY UNIT, (e.g. by lifting or lowering) during operation at 1,1 times the rated voltage at NOMINAL frequency the MEDICAL SUPPLY UNIT shall not produce acoustic energies in excess of 30 dB (A).

The MANUFACTURER shall provide evidence upon request that specified sound levels are not exceeded when measured according to ISO 3744:2010.

201.9.8. Mechanical HAZARDS associated with support systems

201.9.8.1 TENSILE SAFETY FACTORS

MEDICAL SUPPLY UNITS and parts of which are designed to carry additional mechanical loads shall be tested with a test load. The test load shall be calculated by the SAFE WORKING LOAD, as specified by the MANUFACTURER, multiplied by the TENSILE SAFETY FACTORS of IEC 60601-1:2005+A1:2012, 9.8.2 and Table 21.

Compliance is checked by the following test: The test load is applied on the support assembly under test. After 1 min the MEDICAL SUPPLY UNIT meets the requirements of this standard.

201.10 Protection against unwanted and excessive radiation HAZARDS

IEC 60601-1:2005+A1:2012, Clause 10 applies, with the following additions:

201.11 Protection against excessive temperatures and other HAZARDS

IEC 60601-1:2005+A1:2012, Clause 11 applies, with the following additions:

201.11.1 Excessive temperatures in ME EQUIPMENT

201.11.1.101 Temperatures of luminaires

The maximum temperatures of luminaires and their exposed components shall not exceed the maximum temperatures stated in IEC 60598-1:2014.

201.11.2 Fire prevention

201.11.2.2 ME EQUIPMENT and ME SYSTEMS used in conjunction with oxygen-rich environments

201.11.2.2.1 b) 2)

This is achievable by using vented openings in the ENCLOSURE of the MEDICAL SUPPLY UNIT.

201.12 Accuracy of controls and instruments and protection against hazardous outputs

IEC 60601-1:2005+A1:2012, Clause 12 applies.

201.13 HAZARDOUS SITUATIONS and fault conditions

IEC 60601-1:2005+A1:2012, Clause 13 applies, with the following additions:

201.13.2 SINGLE FAULT CONDITIONS

201.13.2.1 * General

An oxidant leak, which is not detected by e.g. an alarm or periodic inspection, shall be considered a NORMAL CONDITION and not a SINGLE FAULT CONDITION.

MEDICAL SUPPLY UNITS shall, when transported, stored, installed, operated in NORMAL USE and maintained according to the instructions of the MANUFACTURER, present no RISKS that are not reduced to an acceptable level using RISK MANAGEMENT PROCEDURES in accordance with ISO 14971:2012 and which are connected with their intended application, in NORMAL CONDITION and in SINGLE FAULT CONDITION.

NOTE Maintenance is considered a NORMAL CONDITION.

201.14 PROGRAMMABLE ELECTRICAL MEDICAL SYSTEMS (PEMS)

IEC 60601-1:2005+A1:2012, Clause 14 applies.

201.15 Construction of ME EQUIPMENT

IEC 60601-1:2005+A1:2012, Clause 15 applies, with the following additions:

201.15.1 Arrangements of controls and indicators of ME EQUIPMENT

Equipment and components incorporated into the MEDICAL SUPPLY UNIT shall comply with the relevant standard(s) for such equipment or components.

201.15.4 ME EQUIPMENT components and general assembly

201.15.4.1 General

Connectors for equipotential earth bonding conductors, if provided, shall be mounted so as to prevent physical damage to the OPERATOR or to the connector.

Compliance is checked by inspection.

If power supplies are fitted and are in connection with nurse call systems, they shall comply with national regulations and IEC 60601-1:2005+A1:2012, 8.9.

201.15.4.3 Batteries

Where batteries are used (e.g. for emergency lighting) they shall be installed to meet the respective standard for the specific application.

201.15.4.3.5 Excessive current and voltage protection

201.15.4.3.5.101 Pulse relays

If pulse relays are fitted, they shall comply with national regulations and IEC 60601-1:2005+A1:2012, 8.9.

201.15.4.101 MEDICAL GAS supply construction

MEDICAL GAS pipelines in MEDICAL SUPPLY UNITS shall be constructed to the requirements of ISO 7396-1:2007.

NOTE 1 Copper is the preferred material for all MEDICAL GAS pipelines including vacuum.

NOTE 2 Pipes to pressure gauges and other measuring and control equipment can have smaller cross-sections.

- Pipeline joints shall be made in accordance with ISO 7396-1:2007. Cutting ring connections shall not be used.

- *Flexible hoses and hose assemblies (i.e. flexible hoses with connectors) shall not be used within MEDICAL SUPPLY UNITS except for the OPERATOR-adjustable portions (e.g. in ceiling pendants).

- If flexible hoses and hose assemblies are used:

- means shall be provided to allow periodic inspection and replacement;

- they shall comply with ISO 5359:2014 except for:

subclauses 4.4.4 (resistance to occlusion), 4.4.7(gas-specificity), 4.4.8 (end connectors), 4.4.9 (design of NIST connectors), 4.4.10 (design of DISS connectors), and 4.4.11 (design of SIS connectors);

- If accessible to the OPERATOR for removal, they shall be incorporated into hose assemblies which comply with ISO 5359:2014 except for 4.4.4;

- When tested for occlusion the reduction of a flow of 20 l/min shall not exceed 10 % and the hose shall show no visible deformation in the following condition:

- For hoses for compressed MEDICAL GASES:

- test pressure: 320 kPa

- test force: 200 N

- For hoses for vacuum:

- test pressure: 10 kPa absolute pressure

- test force: 200 N;

- The ACCOMPANYING DOCUMENTS for the MEDICAL SUPPLY UNIT shall include a PROCEDURE for, and the recommended frequency of, inspection and replacement of the flexible hoses and shall specify the tests to be carried out following such replacement (see 201.7.9.2.16 a);

- If hose assemblies are used, they shall comply with ISO 5359:2014 except for 4.4.4 and the ACCOMPANYING DOCUMENTS for the MEDICAL SUPPLY UNIT shall include a PROCEDURE for, and the recommended frequency of, inspection and replacement of the hose assemblies (see 201.7.9.2.16 a).

- The connection to a MEDICAL GAS PIPELINE SYSTEM shall be in accordance with ISO 7396-1:2007.

- Constructional provisions shall be made so that piping is not exposed to temperatures above 50 °C and flexible hoses, if used, are not exposed to temperatures above 40 °C caused by e.g. lighting facilities, transformers, etc.
- Control knobs and spindles of flow control valves, if fitted, shall be captive such that they cannot be disengaged without the use of a TOOL.
- Each electrical COMPARTMENT within a MEDICAL SUPPLY UNIT shall be separated from the gas and liquid COMPARTMENTS by a barrier except where flexible hoses are used for MEDICAL GAS supply. If electrical cables are installed together with flexible hoses or pipes for MEDICAL GAS supply, the cables shall be insulated and sheathed, or installed in a flexible conduit complying with IEC 61386-1:2008 or national standards, or separated by more than 50 mm. Cables of varying voltages shall be installed in accordance with EN 50174-1:2009+A2:2014 and EN 50174-2:2009+A2:2014 or national standards. Liquid COMPARTMENTS, when mounted horizontally, shall be located below electrical COMPARTMENTS.

NOTE 3 The 50 mm of separation is in accordance with the requirements of ISO 7396-1:2007.

- Terminal units for oxidizing MEDICAL GASES, for ANAESTHETIC GAS SCAVENGING SYSTEMS, for PLUME EVACUATION SYSTEMS and for liquids shall be located at least 0,2 m from any electrical component which can spark in NORMAL CONDITION or in SINGLE FAULT CONDITION. This does not apply to components where the value of the root mean square (RMS) voltage with no load and the RMS value of the short circuit current do not exceed 10 VA (e.g. intercommunication, voice, data, TV components). The distance shall be measured on the surface of the unit from the centre line of the terminal unit to the nearest exposed part of the electrical accessory/component.

201.15.4.102 ANAESTHETIC GAS SCAVENGING SYTEM construction

- The construction of the ANAESTHETIC GAS SCAVENGING SYTEM shall comply with ISO 7396-2:2007.
- Flexible hoses for ANAESTHETIC GAS SCAVENGING SYTEMs shall not be used within MEDICAL SUPPLY UNITS except for the OPERATOR-adjustable portions (e. g. in ceiling pendants) and for measuring and control wires (e. g. wiring between indicators and ejector).
- If flexible hoses are used for the exhaust air the material of the hoses in contact with the gas shall be compatible with anaesthetic vapours.
- If flexible hoses are used, means shall be provided to allow periodic inspection and replacement.
- If flexible hoses are used, the ACCOMPANYING DOCUMENTS for the MEDICAL SUPPLY UNIT shall include a PROCEDURE for, and the recommended frequency of, inspection and replacement of the flexible hoses and shall specify the tests to be carried out following such replacement (see 201.7.9.2.16 a)).
- Measuring and control wires shall meet the requirements of ISO 5359:2014, 4.4.2, 4.4.3 and 4.4.4.

ANAESTHETIC GAS SCAVENGING SYSTEMS according to ISO 7396-2:2007 used in ceiling pendants shall have plastic hoses for exhaust air in the MEDICAL SUPPLY UNIT.

If the exhaust air system can have a negative pressure in NORMAL USE the hose shall withstand twice the value of the negative pressure over the service lifetime of the MEDICAL SUPPLY UNIT. The material of the plastic hoses shall withstand enflurane, sevoflurane, isoflurane, halothane, desflurane and cleaning and disinfection agents and shall have no permanent deformation or cracking after the following:

1. 10⁴ flexing cycles

1. 150 N tensile loads.
2. 60 N pressure load from outside according to ISO 5359:2014, Figure 7.

If the drive system is an exhaust ejector or ventilator and a gauge pressure between 0 kPa and -10 kPa is possible by design, plastic hoses may be used. Where a negative pressure exceeds -10 kPa, a hose in accordance with ISO 5359:2014 shall be used.

If drive system ejectors and hoses are used in an exhaust hose, the ejector shall be placed directly on the connection point of the rigid tubing. If hoses are used according to ISO 5359:2014 the position of the ejector is independent.

201.15.4.103 Liquid supply construction

- Pipelines for potable water (warm or cold) and cooling water (warm or cold) shall be made of copper or stainless steel.

NOTE 1 Attention is drawn to the antimicrobial properties of copper. See [4] in the Bibliography.

- Pipelines for demineralized water (cold), distilled water, dialysing concentrate and dialysing permeate shall be made of corrosion-resistant material.
- Flexible hoses shall not be used within MEDICAL SUPPLY UNITS except for the OPERATOR-adjustable portions (e.g. in ceiling pendants).
- If flexible hoses are used, means to allow periodic inspection and replacement shall be provided.
- If flexible hoses are used, the ACCOMPANYING DOCUMENTS for the MEDICAL SUPPLY UNIT shall include a PROCEDURE for, and the recommended frequency of, inspection and replacement of the flexible hoses and shall specify the tests to be carried out following such replacement [see 201.7.9.2.16 a)].
- The material selected for flexible hoses for use with any liquid supply shall be compatible with the liquid contained in those hoses with regard to strength, long-term stability and corrosion resistance under the operating conditions specified by the MANUFACTURER.
- Pipes and hoses for MEDICAL GASES can be installed together with piping for liquids. If mounted together horizontally, gas pipes shall be located above liquid pipes.
- Pipelines for dialysing solutions should be installed in a single recirculating loop.
- Hot water or wet steam can be used for pasteurisation of pipelines for dialysing solutions. Means should be provided to protect other components from excessive temperature.
- Turbulence and dead spaces should be avoided by design.
- Connections in metal pipelines and branches to the terminal units shall be welded or brazed. Flaring and similar methods shall not be used. Cutting ring connections or compression joints for copper pipes shall not be used. To prevent oxide formation inside the pipes they shall be filled and purged with a suitable inert gas during welding or brazing. Pipe connections in pipelines for liquids shall be bonded by means of sleeves without changes in internal diameter.
- The liquid supply system shall be designed and manufactured to minimize health RISKS due to substances leached from the system.

201.15.4.104 Terminal unit construction

201.15.4.104.1. Terminal units for MEDICAL GASES shall comply with ISO 9170-1:2008.

201.15.4.104.2. Terminal units for ANAESTHETIC GAS SCAVENGING SYSTEMS shall comply with ISO 9170-2:2008.

201.15.4.104.3 Terminal units for liquids

Terminal units for liquids shall comprise either:

a) a flow control valve fitted with a check valve and at the outlet a hose insert for the following:

potable water, cold;

potable water, warm;

cooling water;

cooling water, feed-back;

de-mineralized water;

distilled water; or

b) a quick-connect socket and probe for the following:

dialysing concentrate;

dialysing permeate.

— Control knobs and spindles of flow control valves, if fitted, shall be captive such that they cannot be disengaged without the use of a TOOL.

— Quick-connect sockets and probes, if fitted, shall both be equipped with a check valve to ensure automatic closure upon disconnection.

— If probes and sockets are used for dialysing concentrate and dialysing permeates, the probe shall be fitted on the MEDICAL SUPPLY UNIT.

— The materials shall be compatible with the liquids under the operating conditions specified by the MANUFACTURER.

— The NOMINAL internal diameters for quick-connect sockets and probes, if fitted, shall be as follows:

— dialysing concentrate 4 mm;

— dialysing permeate 6 mm.

— If quick-connect sockets and probes are used for the discharge of dialysing solutions, they shall have different dimensions from all the others used.

Compliance with 201.15.4.104.3 a) to d) and f) and g) shall be checked by visual inspection.

201.15.101 Venting

Where oxygen or nitrous oxide MEDICAL GAS pipelines or terminal units are contained within a MEDICAL SUPPLY UNIT, the specific chamber housing these components shall be vented to atmosphere.

Compliance is checked by a simulated leakage test with a 1 l/min flow of oxygen into the ENCLOSURE for at least 10 min. The concentration of oxygen shall not be higher than 25 % (v/v) inside the ENCLOSURE of the MEDICAL SUPPLY UNIT.

201.16 ME SYSTEMS

IEC 60601-1:2005+A1:2012, Clause 16 applies.

201.17 Electromagnetic compatibility of ME EQUIPMENT and ME SYSTEMS

IEC 60601-1:2005+A1:2012, Clause 17 applies.

Addition:

202 MEDICAL ELECTRICAL EQUIPMENT - part 1-2 General requirements for BASIC SAFETY and ESSENTIAL PERFORMANCE – Collateral standard: Electromagnetic disturbances – Requirements and tests

IEC 60601-1-2:2014 applies.

206 MEDICAL ELECTRICAL EQUIPMENT - part 1-6 General requirements for BASIC SAFETY and ESSENTIAL PERFORMANCE – Collateral standard: Usability

IEC 60601-1-6:2010 applies.

IEC 60601-1:2005+A1:2012 Annexes A to L apply.

Annex AA **(informative)**

Rationale

The following corresponds to the clauses and subclauses in this International Standard marked with an asterisk (*). The numbering is, therefore, not consecutive.

AA.201.13.2.1 General

A fault condition which is not detected can exist for a long period of time. Under these circumstances it is not acceptable to regard a further fault as a second fault condition, which can be disregarded. Such a SINGLE FAULT CONDITION must be regarded as a NORMAL CONDITION.

AA.201.15.4.101

Hoses within MEDICAL SUPPLY UNITS are not freely accessible to the OPERATOR and are protected by the ENCLOSURE. The resistance to occlusion specified in 4.4.4 of ISO 5359:2014 can only be met by very hard hoses which are relatively inflexible. Hoses within MEDICAL SUPPLY UNITS which are intended to allow movement (e.g. in ceiling pendants) need to be very flexible. Hoses made from materials, which allow such flexibility, have a lower resistance to occlusion. However, since occlusion is not a significant RISK to hoses within MEDICAL SUPPLY UNITS, a lower value of 200 N for the occlusion test is acceptable.

Bibliography

- [1] EN 60446, *Basic and safety principles for man-machine interface, marking and identification — Identification of conductors by colours or alphanumerics*
- [2] EN 13348, *Copper and copper alloys — Seamless, round copper tubes for medical gases or vacuum*
- [3] EN 61140, *Protection against electric shock. Common aspects for installation and equipment*
- [4] QUIGLEY, P. Considering copper. *Standardization News, September/October 2010; pp.36-41*

Index of defined terms used in this particular standard

ACCOMPANYING DOCUMENTS	IEC 60601-1:2005+A1:2012, 3.4
ANAESTHETIC GAS SCAVENGING SYSTEM	ISO 7396-2:2007, 3.11
APPLIED PART	IEC 60601-1:2005+A1:2012, 3.8
BASIC SAFETY	IEC 60601-1:2005+A1:2012, 3.10
CLASS I	IEC 60601-1:2005+A1:2012, 3.13
COMPARTMENT	201.3.101
ENCLOSURE	201.3.26
ESSENTIAL PERFORMANCE	IEC 60601-1:2005+A1:2012, 3.27
HAZARD	IEC 60601-1:2005+A1:2012, 3.39
HAZARDOUS SITUATION	IEC 60601-1:2005+A1:2012, 3.40
JUNCTION POINT	201.3.102
MAINS PART	IEC 60601-1:2005+A1:2012, 3.49
MANUFACTURER	IEC 60601-1:2005+A1:2012, 3.55
MEDICAL ELECTRICAL EQUIPMENT (ME EQUIPMENT)	IEC 60601-1:2005+A1:2012, 3.63
MEDICAL ELECTRICAL SYSTEM (ME SYSTEM)	IEC 60601-1:2005+A1:2012, 3.64
MEDICAL GAS	201.3.103
MEDICAL GAS PIPELINE SYSTEM	ISO 7396-1:2007, 3.29
MEDICAL SUPPLY UNIT	201.3.103
NOMINAL (value)	IEC 60601-1:2005+A1:2012, 3.69
NORMAL CONDITION	IEC 60601-1:2005+A1:2012, 3.70
NORMAL USE	IEC 60601-1:2005+A1:2012, 3.71
OPERATOR	IEC 60601-1:2005+A1:2012, 3.73
PATIENT	IEC 60601-1:2005+A1:2012, 3.76
PLUME EVACUATION SYSTEM (PES)	201.3.104
PROCEDURE	IEC 60601-1:2005+A1:2012, 3.88
PROGRAMMABLE ELECTRICAL MEDICAL SYSTEMS (PEMS)	IEC 60601-1:2005+A1:2012, 3.90
PROTECTIVE EARTH TERMINAL	IEC 60601-1:2005+A1:2012, 3.95
RESPONSIBLE ORGANIZATION	IEC 60601-1:2005+A1:2012, 3.101
RISK	IEC 60601-1:2005+A1:2012, 3.116
SAFE WORKING LOAD	IEC 60601-1:2005+A1:2012, 3.109
SINGLE FAULT CONDITION	IEC 60601-1:2005+A1:2012, 3.117
SUPPLY MAINS	IEC 60601-1:2005+A1:2012, 3.120
TENSILE SAFETY FACTORS	IEC 60601-1:2005+A1:2012, 3.121
TOOL	IEC 60601-1:2005+A1:2012, 3.11

