**Safety of machinery — Integrated
manufacturing systems — Basic
requirements**

*Sécurité des machines — Systèmes de fabrication intégrés —
Prescriptions fondamentales*



Reference number
ISO 11161:2007(E)

© ISO 2007

PDF disclaimer

This PDF file may contain embedded typefaces. In accordance with Adobe's licensing policy, this file may be printed or viewed but shall not be edited unless the typefaces which are embedded are licensed to and installed on the computer performing the editing. In downloading this file, parties accept therein the responsibility of not infringing Adobe's licensing policy. The ISO Central Secretariat accepts no liability in this area.

Adobe is a trademark of Adobe Systems Incorporated.

Details of the software products used to create this PDF file can be found in the General Info relative to the file; the PDF-creation parameters were optimized for printing. Every care has been taken to ensure that the file is suitable for use by ISO member bodies. In the unlikely event that a problem relating to it is found, please inform the Central Secretariat at the address given below.



COPYRIGHT PROTECTED DOCUMENT

© ISO 2007

All rights reserved. Unless otherwise specified, no part of this publication may be reproduced or utilized in any form or by any means, electronic or mechanical, including photocopying and microfilm, without permission in writing from either ISO at the address below or ISO's member body in the country of the requester.

ISO copyright office
Case postale 56 • CH-1211 Geneva 20
Tel. + 41 22 749 01 11
Fax + 41 22 749 09 47
E-mail copyright@iso.org
Web www.iso.org

Published in Switzerland

Contents

Page

Foreword.....	v
Introduction	vi
1 Scope	1
2 Normative references	1
3 Terms and definitions	2
4 Strategy for risk assessment and risk reduction	6
4.1 General.....	6
4.2 Specification of the limits of the IMS.....	6
4.3 Determination of the task.....	6
4.4 Identifying hazardous situations.....	8
4.5 Risk estimation and risk evaluation.....	8
4.6 Risk reduction	8
5 Risk assessment.....	10
5.1 Specifications of the IMS	10
5.2 Identification of hazards and hazardous situations.....	12
5.3 Risk estimation	13
5.4 Risk evaluation.....	14
6 Risk reduction	14
6.1 Protective measures.....	14
6.2 Validation of the protective measures.....	14
7 Task zone(s)	14
7.1 General.....	14
7.2 Determination	15
7.3 Design	15
7.4 Functional analysis.....	16
8 Safeguarding and span of control	16
8.1 Safeguarding of task zones	16
8.2 Span of control.....	17
8.3 Electrical equipment requirements.....	17
8.4 Modes.....	17
8.5 Safeguards	18
8.6 Protective measures when safeguards are suspended.....	18
8.7 Muting and blanking	20
8.8 Control	20
8.9 Reset of perimeter safeguarding devices	21
8.10 Start/restart.....	21
8.11 Emergency stop	22
8.12 Measures for the escape and rescue of trapped persons	22
9 Information for use	22
9.1 General.....	22
9.2 Marking	23
10 Validation of the design	23
10.1 Validation that the design meets the requirements	23
10.2 Validation of the protective measures.....	23
Annex A (informative) Examples of integrated manufacturing systems (IMs).....	24
Annex B (informative) Flow of information between the integrator, user and suppliers.....	27

Annex C (informative) Span of control examples within an IMS 28
Annex D (informative) Temporary observation of the automatic process 32
Bibliography 36

© ISO 2007 – All rights reserved

Foreword

ISO (the International Organization for Standardization) is a worldwide federation of national standards bodies (ISO member bodies). The work of preparing International Standards is normally carried out through ISO technical committees. Each member body interested in a subject for which a technical committee has been established has the right to be represented on that committee. International organizations, governmental and non-governmental, in liaison with ISO, also take part in the work. ISO collaborates closely with the International Electrotechnical Commission (IEC) on all matters of electrotechnical standardization.

International Standards are drafted in accordance with the rules given in the ISO/IEC Directives, Part 2.

The main task of technical committees is to prepare International Standards. Draft International Standards adopted by the technical committees are circulated to the member bodies for voting. Publication as an International Standard requires approval by at least 75 % of the member bodies casting a vote.

Attention is drawn to the possibility that some of the elements of this document may be the subject of patent rights. ISO shall not be held responsible for identifying any or all such patent rights.

ISO 11161 was prepared by Technical Committee ISO/TC 199, *Safety of machinery*, in accordance with the Agreement on technical cooperation between ISO and CEN (Vienna Agreement).

This second edition cancels and replaces the first edition (ISO 11161:1994), which has been technically revised.

Introduction

The structure of safety standards in the field of machinery is as follows:

- a) Type-A standards (basic safety standards) giving basic concepts, principles for design, and general aspects that can be applied to all machinery.
- b) Type-B standards (generic safety standards) dealing with one safety aspect or one type of safeguard that can be used across a wide range of machinery:
 - type-B1 standards on particular safety aspects (e.g. safety distances, surface temperature, noise);
 - type-B2 standards on safeguards (e.g. two-hand controls, interlocking devices, pressure sensitive devices, guards).
- c) Type-C standards (machine safety standards) dealing with detailed safety requirements for a particular machine or group of machines.

This International Standard is a type-B1 standard as stated in ISO 12100-1.

An integrated manufacturing system (IMS, see 3.1) can be very different in terms of size and complexity, and can incorporate different technologies that require diverse expertise and knowledge.

An integrated manufacturing system should be considered to be a whole new and different machine rather than simply its parts combined. The integrator (see 3.10) needs the cooperation of entities who individually know only a part of the whole. Where there are requirements for frequent manual interventions to parts of the IMS, e.g. inspections, maintenance, set-up, it can be impractical or unnecessary to stop the whole IMS. This International Standard gives requirements to provide for the safety of individuals who perform these tasks. Safeguarding for these tasks relates to the concept and use of “task zones”.

The aim of this International Standard is to describe how to apply the requirements of ISO 12100-1:2003, ISO 12100-2:2003 and ISO 14121 in this specific context.

A general configuration of an integrated manufacturing system is shown in Figure 1.

Some examples of integrated manufacturing systems are included in Annex A.

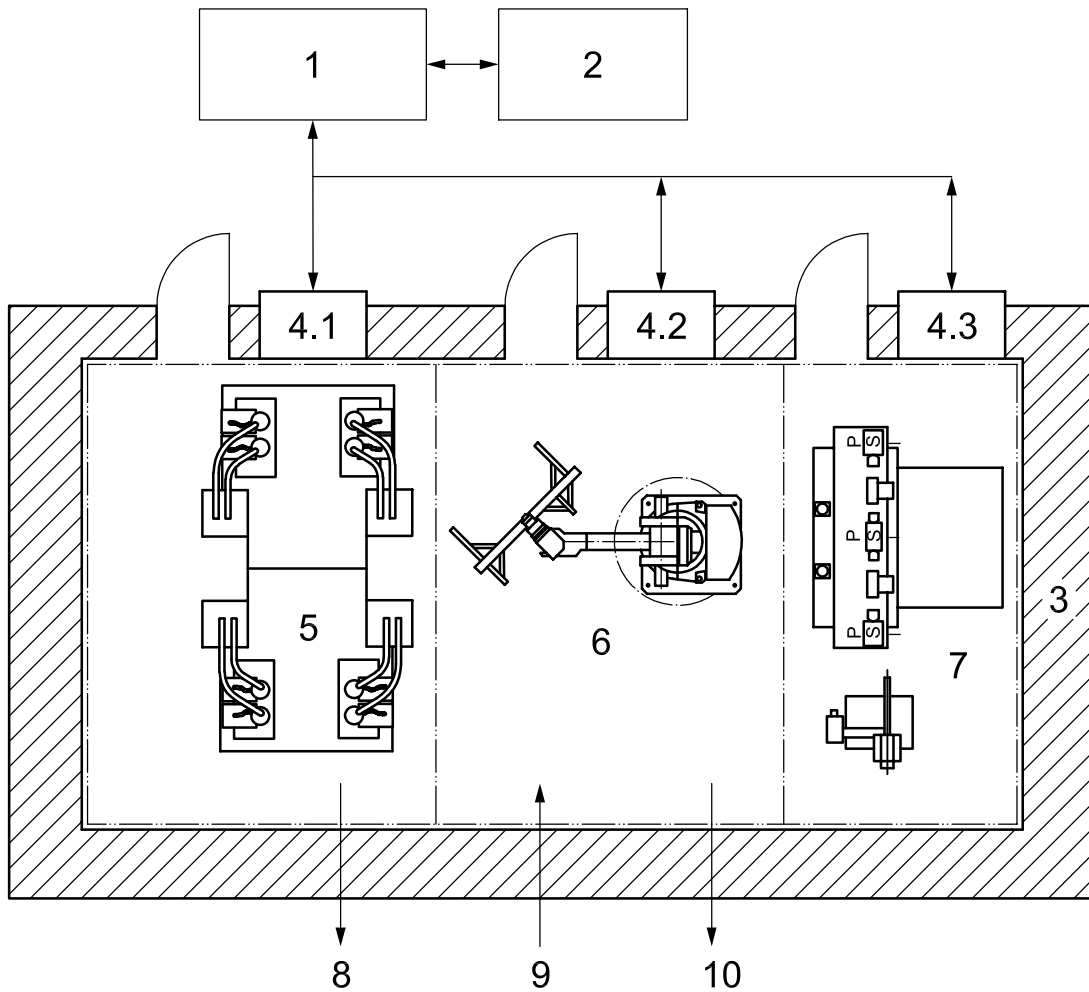

Key

- | | |
|---------------------|------------------------------|
| 1 control | 6 hazard zone B |
| 2 operator pendant | 7 hazard zone C |
| 3 safeguarded space | 8 scrap and expendables flow |
| 4 local controls | 9 raw material flow |
| 5 hazard zone A | 10 finished goods |

Figure 1 — Configuration of an IMS

.....

Safety of machinery — Integrated manufacturing systems — Basic requirements

1 Scope

This International Standard specifies the safety requirements for integrated manufacturing systems (IMS) that incorporate two or more interconnected machines for specific applications, such as component manufacturing or assembly. It gives requirements and recommendations for the safe design, safeguarding and information for the use of such IMSs (see Figure 1 for the basic configuration of an IMS).

NOTE 1 In the context of this International Standard, the term *system* refers to an integrated manufacturing system.

NOTE 2 In the context of this International Standard, the term *machine* refers to the component machines and associated equipment of the integrated manufacturing system.

This International Standard is not intended to cover safety aspects of individual machines and equipment that may be covered by standards specific to those machines and equipment. Therefore it deals only with those safety aspects that are important for the safety-relevant interconnection of the machines and components. Where machines and equipment of an integrated manufacturing system are operated separately or individually, and while the protective effects of the safeguards provided for production mode are muted or suspended, the relevant safety standards for these machines and equipment apply.

2 Normative references

The following referenced documents are indispensable for the application of this document. For dated references, only the edition cited applies. For undated references, the latest edition of the referenced document (including any amendments) applies.

ISO 12100-1:2003, *Safety of machinery — Basic concepts, general principles for design — Part 1: Basic terminology, methodology*

ISO 12100-2:2003, *Safety of machinery — Basic concepts, general principles for design — Part 2: Technical principles*

ISO 13849-1:2006, *Safety of machinery — Safety-related parts of control systems — Part 1: General principles for design*

ISO 13849-2:2003, *Safety of machinery — Safety-related parts of control systems — Part 2: Validation*

ISO 13850:2006, *Safety of machinery — Emergency stop — Principles for design*

ISO 14120:2002, *Safety of machinery — Guards — General requirements for the design and construction of fixed and movable guards*

ISO 14121:1999, *Safety of machinery — Principles of risk assessment*

ISO 14122-1:2001, *Safety of machinery — Permanent means of access to machinery — Part 1: Choice of a fixed means of access between two levels*

ISO 11161:2007(E)

ISO 14122-2:2001, *Safety of machinery — Permanent means of access to machinery — Part 2: Working platforms and walkways*

ISO 14122-3:2001, *Safety of machinery — Permanent means of access to machinery — Part 3: Stairways, stepladders and guard-rails*

ISO 14122-4:2004, *Safety of machinery — Permanent means of access to machinery — Part 4: Fixed ladders*

IEC 60204-1:2005, *Safety of machinery — Electrical equipment of machines — Part 1: General requirements*

IEC 62061:2005, *Safety of machinery — Functional safety of safety-related electrical, electronic and programmable electronic control systems*

3 Terms and definitions

For the purposes of this document, the following definitions apply:

3.1

integrated manufacturing system

IMS

group of machines working together in a coordinated manner, linked by a material-handling system, interconnected by controls (i.e. IMS controls), for the purpose of manufacturing, treatment, movement or packaging of discrete parts or assemblies

NOTE See also Annex A.

3.2

detection zone

zone within which a specified test piece will be detected by the electro-sensitive protective equipment (ESPE)

[IEC/TS 62046:2004, 3.1.3]

3.3

emergency stop

function which is intended:

- to avert arising or to reduce existing hazards to persons, damage to machinery or to work in progress;
- to be initiated by a single human action

NOTE ISO 13850 gives detailed provisions.

[ISO 12100-1:2003, 3.37]

3.4

enabling device

additional manually operated device used in conjunction with a start control and which, when continuously actuated, allows a machine to function

NOTE IEC 60204-1:2005, 9.2.5.8 gives provisions on enabling devices.

[ISO 12100-1:2003, 3.26.2]

3.5**guard**

physical barrier, designed as part of the machine, to provide protection

NOTE 1 A guard may act:

- alone; it is then only effective when it is “closed” for a movable guard or “securely held in place” for a fixed guard;
- in conjunction with an interlocking device with or without guard locking; in this case, protection is ensured whatever the position of the guard.

NOTE 2 Depending on its construction, a guard may be called e.g. casing, shield, cover, screen, door, enclosing guard.

NOTE 3 See ISO 12100-2:2003, 5.3.2, and ISO 14120 for types of guards and their requirements.

[ISO 12100-1:2003, 3.25]

3.6**harm**

physical injury or damage to health

[ISO 12100-1:2003, 3.5]

3.7**hazard**

potential source of harm

NOTE 1 The term hazard can be qualified in order to define its origin (e.g. mechanical hazard, electrical hazard) or the nature of the potential harm (e.g., electric shock hazard, cutting hazard, toxic hazard, fire hazard).

NOTE 2 The hazard envisaged in this definition:

- either is permanently present during the intended use of the machine (e.g. motion of hazardous moving elements, electric arc during a welding phase, bad posture; noise emissions; high temperature);
- or may appear unexpectedly (e.g. explosion, crushing hazard as a consequence of an unintended/unexpected start-up, ejection as a consequence of a breakage, fall as a consequence of acceleration/deceleration).

[ISO 12100-1: 2003, 3.6]

3.8**hazard zone**

danger zone

any space within and/or around machinery in which a person can be exposed to a hazard

[ISO 12100-1:2003, 3.10]

3.9**hazardous situation**

circumstance in which a person is exposed to at least one hazard

NOTE The exposure can immediately or over a period of time result in harm.

[ISO 12100-1:2003, 3.9]

3.10

integrator

entity who designs, provides, manufactures or assembles an integrated manufacturing system and is in charge of the safety strategy, including the protective measures, control interfaces and interconnections of the control system

NOTE The integrator may be a manufacturer, assembler, engineering company or the user.

3.11

interlocking device

interlock

mechanical, electrical or other type of device, the purpose of which is to prevent the operation of hazardous machine functions under specified conditions (generally as long as a guard is not closed)

[ISO 12100-1: 2003, 3.26.1]

3.12

local control

state in which the control of a task zone can only be performed at that task zone

3.13

muting

temporary automatic suspension of a safety function(s) by safety-related parts of control systems

[ISO 13849-1:2006, 3.1.8]

3.14

operator

person or persons given the task of installing, using, adjusting, maintaining, cleaning, repairing or transporting machinery

3.15

protective measure

measure intended to achieve risk reduction, implemented

- by the designer (inherently safe design, safeguarding and complementary protective measures, information for use) and
- by the user (organization: safe working procedures, supervision, permit-to-work systems; provision and use of additional safeguards; use of personal protective equipment; training)

[ISO 12100-1:2003, 3.18]

3.16

protective device

safeguard other than a guard

[ISO 12100-1:2003, 3.26]

3.17

risk

combination of the probability of occurrence of harm and the severity of that harm

[ISO 12100-1:2003, 3.11]

3.18**safeguard**

guard or protective device

[ISO 12100-1:2003, 3.24]

3.19**safeguarded space**

space determined by the protective measures such that the hazard(s) covered by these measures cannot be reached

3.20**safeguarding**

protective measure using safeguards to protect persons from the hazards which cannot reasonably be eliminated or risks which cannot be sufficiently limited by inherently safe design measures

NOTE ISO 12100-2:2003, Clause 5, deals with safeguarding.

[ISO 12100-1:2003, 3.20]

3.21**safety function**

function of a machine whose failure can result in an immediate increase of the risk(s)

[ISO 12100-1:2003, 3.28]

3.22**safe working procedure**

specified procedure intended to reduce the possibility of injury while performing an assigned task

3.23**span of control**

predetermined portion of the IMS under control of a specific device

3.24**supplier**

entity (e.g. designer, manufacturer, contractor, installer, integrator) who provides equipment or services associated with the IMS or a portion of the IMS

NOTE The user may also act in the capacity of a supplier.

3.25**task zone**

any predetermined space within and/or around the IMS in which an operator can perform work

NOTE See also hazard zone and safeguarded space.

3.26**trouble shooting****fault finding**

act of methodically determining the reason that the IMS, or portions of the IMS, has failed to perform the task or function as intended

3.27**user**

entity who utilizes and maintains the IMS

4 Strategy for risk assessment and risk reduction

4.1 General

The strategy for risk assessment and risk reduction of an IMS shall be in accordance with ISO 12100-1, ISO 12100-2 and ISO 14121.

The integrator shall consult with the user and the suppliers (see Annex B) of the component machines and associated equipment to achieve adequate reduction of risk. The integrator shall review the technical aspects and develop the information for use of the IMS in accordance with Clause 9.

The IMS shall be designed to facilitate safe manual interventions, including maintenance. For some manual interventions, it can be impractical to stop the whole IMS, in which case the IMS shall be segregated into zone(s) where operators can perform their tasks safely. Clause 5 applies to the risk assessment, including

- specification of the IMS (5.1),
- identification of hazards and hazardous situations (5.2),
- risk estimation (5.3), and
- risk evaluation (5.4).

Clause 6 applies to risk reduction including

- protective measures (6.1), and
- validation of protective measures (6.2).

IMS risk assessment and risk reduction is an iterative process described in the following steps (see Figure 2 of ISO 12100-1:2003).

4.2 Specification of the limits of the IMS

In order to perform an adequate risk assessment, the following basis IMS parameters shall be defined:

- functionalities;
- limits;
- interfaces between the different parts of the IMS.

See Figure 2.

4.3 Determination of the task

The integrator shall determine the foreseeable tasks (for the IMS multiple configurations) and their associated requirements of location and access. See Figure 3.

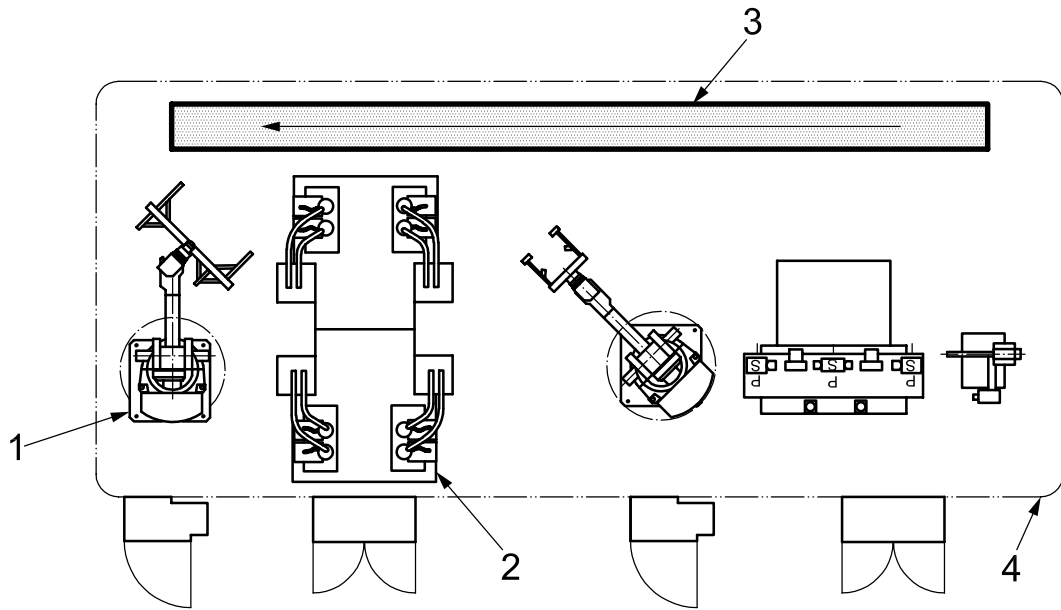

Key

- | | |
|----------------------------|---|
| 1 machine A – robot | 3 machine C – material handling system (conveyor) |
| 2 machine B – machine tool | 4 IMS |

Figure 2 — Specification of the limits of the IMS

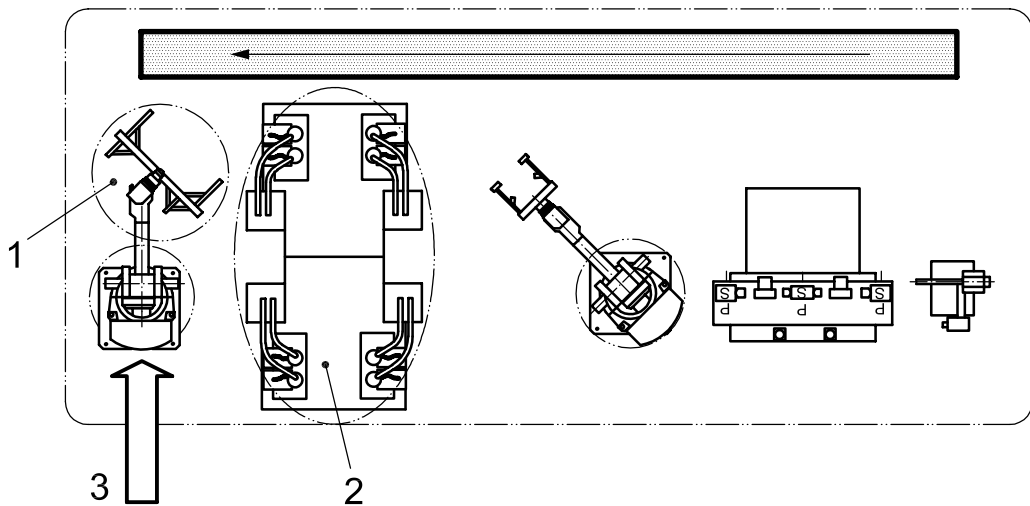

Key

- 1 task 1: tool changing
- 2 task 2: cleaning
- 3 access to task 1 and task 2

Figure 3 — Determination of tasks (requirements, location, access)

4.4 Identifying hazardous situations

The IMS risk assessment shall cover hazardous situations resulting from

- integration of the component machines and associated equipment,
- any alterations to the protective measures of the machine(s), or
- change of use of the machine(s).

See Figure 4.

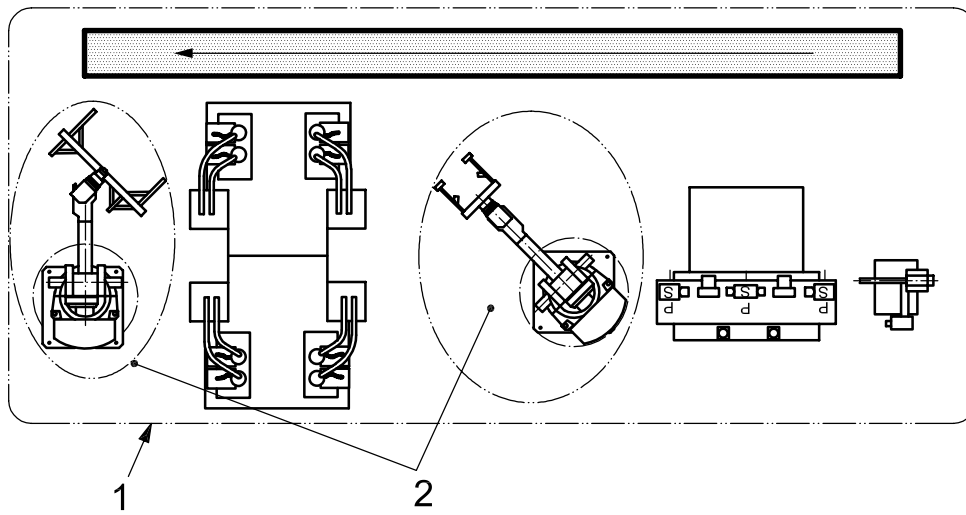

Key

- 1 IMS
- 2 hazard zones

Figure 4 — Identification of hazards/hazard zones and associated hazardous situations

4.5 Risk estimation and risk evaluation

The integrator shall estimate and evaluate risk for each identified hazard and hazardous situation within each task zone.

4.6 Risk reduction

The integrator shall eliminate the hazard or reduce the risks associated with the hazard by the hierarchy of protective measures according to ISO 12100-1:2003, as follows:

- elimination of the hazard by design;
- risk reduction by design requirements and determination of task zone(s);
- risk reduction by safeguarding and complementary measures, including span of control;
- risk reduction by providing information for use (see Clause 9).

See Figures 5 and 6.

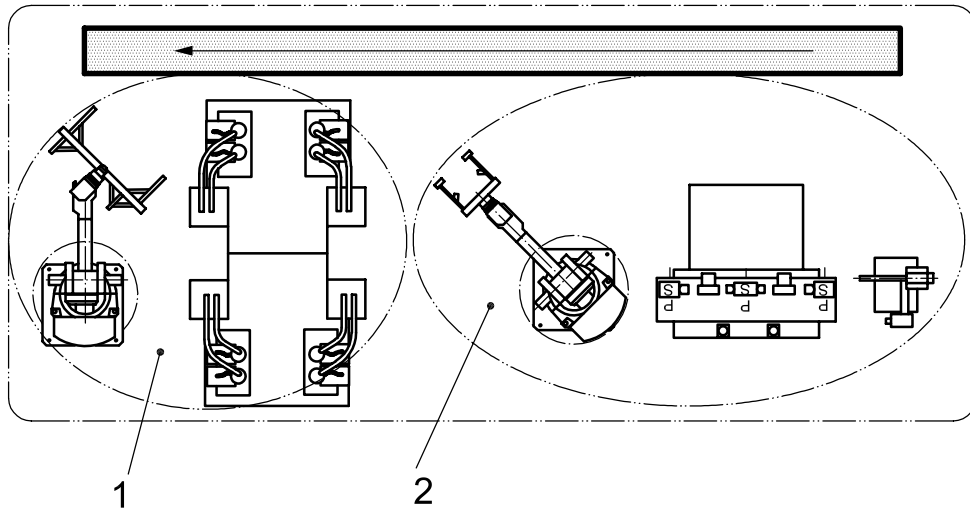

Key

- 1 task zone A
- 2 task zone B

Figure 5 — Determination of the task zone(s)

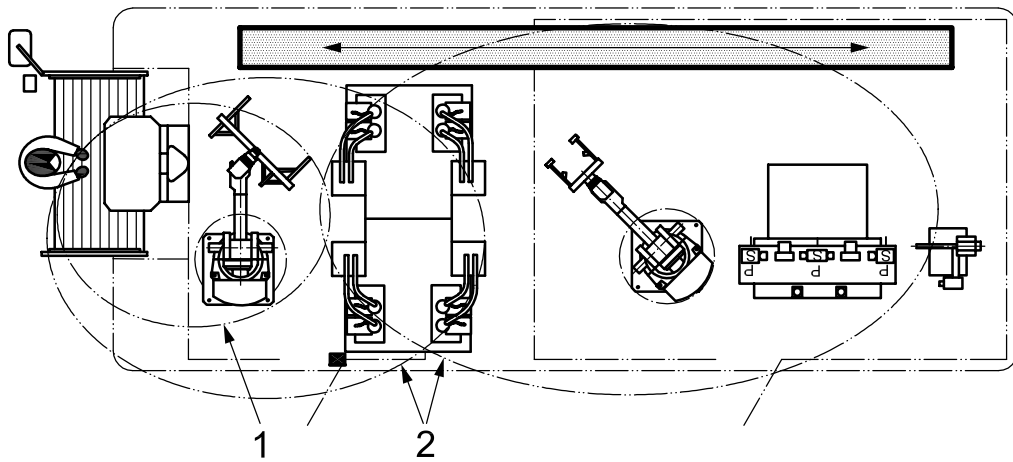

Key

- 1 span of control of light control
- 2 span of control of interlocking device

Figure 6 — Determination of the safeguarding including the span of control

5 Risk assessment

5.1 Specifications of the IMS

5.1.1 Limits

The risk assessment of an IMS begins with the specification of its limits, including determination of the IMS use, space requirements and the lifecycle (see also ISO 12100-1:2003, 5.2). The integrator should consider:

- a) description of functions;
- b) layout including access and configuration capabilities;
- c) description of the interaction of different working processes and manual activities;
- d) analysis of process sequences, including manual interaction;
- e) description of the interfaces;
- f) process flow charts;
- g) foundation plans;
- h) plans and space for material handling;
- i) utility service connections;
- j) available accident records of similar operations or systems;
- k) study of similar system installations;
- l) environmental characteristics.

5.1.2 Functionality

The specification of the functionality of the IMS shall include, but not be limited to:

- a) production rates that take into account work tasks and IMS efficiency(ies);
- b) level of automation, technologies and manufacturing processes;
- c) modes [e.g. manual mode, automatic mode, modes related to a zone or part of a zone, observation mode (see also Annex D)];
- d) machine/IMS multiple configuration requirements;

NOTE Multiple configurations (the designed regrouping and re-zoning of machinery within the IMS) can allow the use of portions of the IMS while other portions are not used or are being used as a stand-alone machine. Multiple configurations can also provide added production flexibility (e.g. the number or variety of parts being produced at the same time).

- e) control functions, including safety-related control functions (see 8.8);
- f) spans of control;
- g) inspection requirements.

5.1.3 Determination of work task(s)

The integrator shall identify and document the human interactions with the IMS. The specification of the work task(s) of the IMS shall include:

- a) the specific work to be performed or accomplished;
- b) location of the work task(s);
- c) frequency and duration of human intervention, including but not limited to quality checks, preventative maintenance, correction of malfunctions;
- d) spans of control of the safeguards to accomplish the work task(s) (e.g. full speed, reduced speed, stopped);
- e) modes needed for work task(s) (e.g. manual mode, automatic mode, modes related to a zone or part of a zone for specific functions or operations, such as setting mode, programming, test mode);
- f) the need for personal protective equipment (e.g. gloves, goggles);
- g) the need for auxiliary equipment (e.g. hand tool, lifting equipment);
- h) ergonomic aspects associated with the task(s) (e.g. posture, mass, size, complexity);
- i) environmental issues that relate to the task(s) (e.g. fresh air, exhaust air and ventilation, lighting, noise and vibration, temperature, humidity, solid waste, liquid waste);
- j) phases of the IMS operation shall be considered, including reasonably foreseeable misuse, when determining work tasks, such as
 - 1) installation,
 - 2) teaching and setting,
 - 3) production (e.g. manual operation by the operator, work piece loading, process control and monitoring),
 - 4) maintenance,
 - 5) correction, trouble shooting and recovery from malfunctions, and
 - 6) dismantling and disposal of the IMS.

The integrator shall also take into account the presence of passers-by not directly concerned with the operation.

5.1.4 Space requirements of the IMS

5.1.4.1 General

The integrator shall specify the space requirements for the IMS, including layout and access requirements.

5.1.4.2 Layout

The design of the IMS layout shall take into account:

- a) access (i.e. ingress and egress paths) and escape paths;

ISO 11161:2007(E)

- b) foreseeable human intervention;
- c) work task(s);
- d) work flow;
- e) spans of control of the safeguards to provide safe access to accomplish the work tasks identified in 5.1.3;
- f) traffic and passers-by.

The layout of the IMS shall be validated to ensure compatibility with the expected use.

5.1.5 Access to the IMS

There shall be safe and easy access to the IMS and shall include paths for:

- operators;
- materials (e.g. raw materials, parts, sub-assemblies, product and scrap);
- mobile equipment (e.g. forklift trucks, trolleys);
- access for maintenance and adjustment;
- access to workstation(s).

NOTE Floor marking may be needed, especially where mobile equipment is used and/or protective devices are installed that can cause a stop. Door swing and direction should be considered.

Access paths and means shall not expose operators to hazards, including falling hazards. Permanent means of access shall be provided, taking into account the frequency and the ergonomic aspects of the task.

Selection and design of platforms, walkways, stairs, stepladders, and fixed ladders shall be in accordance with the relevant part of ISO 14122.

5.2 Identification of hazards and hazardous situations

5.2.1 General

After having determined the IMS limits in accordance with 5.1.1 and a preliminary layout, the integrator shall identify hazard and hazardous situations for each work task, related to:

- a) the machine on which the intervention is performed;
- b) the location of the machine inside the IMS, including hazards from adjacent zones;
- c) the path through the IMS to reach the location to perform the task(s).

5.2.2 Hazards and hazardous situations due to the machine(s) and associated equipment

The assumption of this International Standard is that the suppliers deliver machines that comply with the requirements of ISO 12100-1 and ISO 12100-2 and other safety standards for the machine(s) and associated equipment. The integrator shall determine whether the protective measures implemented by the suppliers are valid for its integration with the IMS. This should be carried out in consultation with the supplier. For each machine, the integrator shall verify whether the conditions of use of the machine due to its integration inside the IMS are consistent with the intended use foreseen by its supplier. A risk assessment shall be carried out on any point of difference. These analyses should be carried out in consultation with the supplier. For example:

- a) The location of the machine inside the IMS exposes it to special environmental constraints not foreseen by its supplier (e.g. a machine can be exposed to an electromagnetic field not foreseen by its supplier).
- b) Due to the location of the machine inside the IMS, interventions cannot be carried out as foreseen by the supplier (e.g. due to the presence of a conveyor, there is no longer access to the machine).
- c) The protective measures taken by the suppliers are no longer valid (e.g. the height of the fixed guard of the machine is no longer enough because of the presence of stairs, from which the hazard zone can be accessed).
- d) Residual risk reduction measures, as described in the information for use for component machines, cannot be followed due to the IMS design or use (e.g. the warning sign cannot be used because it would be obstructed; the guard cannot be used because other machinery is installed).

When a machine is modified (e.g. by removing a guard to enable an automatic feeding by a robot), the integrator shall determine whether new hazardous situations have been created. This should be carried out in consultation with the supplier. When equipment is intended for incorporation into an IMS, the integrator shall determine whether all hazardous situations have been addressed. This should be carried out in consultation with the supplier.

NOTE An example of this kind of equipment may be a sub-assembly of machinery such as a conveyor with its power drive. The conveyor itself normally does not meet all requirements of ISO 12100-2:2003, Clause 4. Other standards may be applicable (e.g. IEC 60204-1).

5.2.3 Hazardous situations due to the location of the equipment

For each machine, the integrator shall assess whether new hazardous situations have been created due to the location of the machine within the IMS. For example:

- a) interaction of individual machines and equipment of the IMS itself;
- b) work in the vicinity of another part of the IMS which is still running;
- c) work at height with a risk of falling;
- d) interfaces between machines and/or zone(s);
- e) the zoning applied to the IMS.

5.2.4 Hazardous situations due to the path

Hazardous situations shall be identified and assessed for paths to each task zone.

5.3 Risk estimation

After the hazards are identified, risk estimation shall be carried out for each hazardous situation by determining the elements of risk, which are derived from a combination of the following elements:

- a) the severity of harm;
- b) the probability of occurrence of that harm, which is a function of
 - the exposure of person(s) to the hazard,
 - the occurrence of a hazardous event,
 - the technical and human possibilities of avoiding or limiting the harm.

5.4 Risk evaluation

Risk evaluation shall be carried out to determine whether adequate safety is reached or if further risk reduction is required.

6 Risk reduction

6.1 Protective measures

Eliminate the hazard or reduce the risks associated with the hazard by the following hierarchy of protective measures:

- a) design requirements of the IMS and zoning (see Clause 7);
- b) safeguarding and span of control (see Clause 8);
- c) information for use (see Clause 9).

NOTE See Figures 5 and 6.

6.2 Validation of the protective measures

Validate that the protective measures adequately reduce the risk.

7 Task zone(s)

7.1 General

Inherently safe design measures are the first and most effective step in the risk reduction process. They are achieved by eliminating hazards or reducing risks by a suitable choice of design features of the component machines or the IMS.

In addition to the measures described in ISO 12100-2:2003, Clause 4, the following inherently safe design measures shall be applied, in order to eliminate or reduce risk:

- a) modify IMS specifications or limits;
- b) change or modify parts of the equipment in order to suppress or reduce hazardous situation(s) or modify some interventions;
- c) modify the layout (e.g. equipment locations, equipment interaction, access paths and means);
- d) limit interventions;
- e) create additional modes of operation.

Before applying other protective measures, repeat the applicable portions of Clauses 5 and 6.

The IMS shall be designed to facilitate safe manual interventions, including maintenance. For some manual interventions, it can be impractical to stop the whole IMS, in which case the IMS shall be segregated into zone(s) where operators can perform their tasks safely.

The primary issue at the IMS level is to determine the best breakdown (or segregation) of the IMS into task zones where the operator(s) can perform work tasks safely. These task zones shall be in a safe condition (e.g. stopped – see also Annex D) while other portions of the IMS continue in automatic operation.

NOTE Task zoning is a measure to create an IMS that is fitted for its function. That means it can achieve its level of production, and can be adjusted and maintained without putting operators at risk when these operations are carried out under the conditions foreseen at the IMS design stage. When this requirement is fulfilled, it should prevent operators from being induced to use unintended operating modes and intervention techniques.

7.2 Determination

Determination of the task zones is an iterative process consisting of the following:

- a) determine tasks: requirements, location, access;
- b) determine hazards/hazards zones and associated hazardous situations (see Figure 4 and Clause 4 of ISO 12100-1:2003);
- c) determine task zone(s).

The following aspects shall be identified on the layout:

- the location(s) for performing tasks;
- the access route through the IMS to reach the servicing point(s) or operating point(s);
- the parts of the IMS that are required to be stopped for safe intervention, and the rest of the IMS that may continue to function;
- the parts of the IMS which, when stopped, will prevent the rest of the IMS from operating and will therefore have an immediate impact on production levels;
- ways to allow the foreseen adjustment, maintenance, repair, cleaning, servicing operations and other tasks to be performed under safe conditions;
- ways to allow the overall IMS to perform its function, (e.g. to achieve its level of production) when these operations are carried out under the conditions foreseen at the IMS design stage.

NOTE See Figure 5.

7.3 Design

To determine the task zone(s), an analysis shall be carried out on the layout of the IMS in order to have an overall understanding of the impact of the foreseen task zones on the functional performance of the IMS.

A task zone can include:

- a) one or several machines and/or equipment;
- b) the space within and/or around the IMS in which an operator performs tasks;
- c) the path(s) to task locations.

Each task zone shall be designed so that the operator is able to easily recognize:

- the perimeter of the task zone;
- the equipment related to the task zone;
- the spans of control of the various control and protective devices (e.g. protective devices, reset of protective devices, enabling devices, emergency stops, control stations, disconnecting means);

- the interfaces with the other task zones;
- work task locations and paths to perform the tasks.

7.4 Functional analysis

As a part of the iterative process, the integrator shall analyse whether the design meets the functional requirements and, if not, the integrator shall

- a) modify the IMS layout, functionality and/or limits,
- b) replace and/or modify equipment in order to reduce the risks associated with interventions,
- c) determine new access paths and means,
- d) modify the way in which interventions shall be performed.

8 Safeguarding and span of control

8.1 Safeguarding of task zones

8.1.1 General

Where, for a task zone, inherently safe design measures do not adequately reduce risks, safeguards shall be provided. Safeguards shall be designed to allow interventions to be performed safely within a task zone.

8.1.2 Task zone interface

Where hazards occur at the interface between task zones, the appropriate safeguarding shall be provided. Interface between task zones are related to

- a) flow of materials from a task zone to an adjacent task zone, and
- b) the access path from a task zone to an adjacent task zone.

8.1.3 Safeguarding of access path interface

When a hazard (identified during risk assessment) occurs at the access path interface, appropriate safeguarding devices shall be provided.

8.1.4 Safeguarding the interface between the flow of materials

Specific safeguarding shall be provided either

- a) to prevent operator access to adjacent task zones from within a task zone, or
- b) to bring the hazards in adjacent task zones to a safe state before the hazard can be reached by the operator.

Where the flow of materials into or out of a task zone can cause tripping of protective devices, then muting or blanking of the devices may be applicable (see 8.7).

8.2 Span of control

8.2.1 General

The span of control of the various control and protective devices related to a task zone shall be determined according to the risk assessment and any relevant type-C standard, taking into account:

- a) the physical layout of the integrated manufacturing system;
- b) the production process itself;
- c) the access necessary for completion of tasks.

8.2.2 Devices having a span of control

Each of the following devices shall have a defined span of control:

- a) emergency stops;
- b) enabling devices;
- c) gate interlocks;
- d) presence-sensing devices;
- e) means for disconnecting;
- f) local control mode.

NOTE One of the devices can have a span of control combined from the spans of controls for other devices (e.g. an emergency stop device can have a span of control that includes the spans of control for two gate interlocks). See Annex C for examples of how the span of control of a safety function might be implemented.

8.3 Electrical equipment requirements

The electrical equipment of the integrated manufacturing system shall be in accordance with IEC 60204-1, taking into account the instructions and recommendations of the equipment suppliers.

NOTE For installation in the building itself, national requirements can apply.

8.4 Modes

8.4.1 General

Modes identified in 5.2.3 shall be provided for the safe performance of tasks.

As far as practicable, tasks requiring manual intervention shall be performed from outside the safeguarded space. Where this is not practicable, an appropriate mode(s) shall be provided.

At least two modes shall be provided as follows:

- automatic mode;
- manual mode (e.g. setting, programming, testing).

NOTE 1 These modes can be related to the whole IMS, or can be local control modes and related only to a task zone or certain machine(s) and/or certain equipment within the task zone. For local control, see 8.8.3.

NOTE 2 A task zone may be, for example, composed of a robot, a conveyor, a milling machine. Each of these component machines may be fitted with its own modes, which can be different.

8.4.2 Mode selection

When the IMS has different control modes (e.g. automatic, setting, process change-over, teaching, troubleshooting, cleaning, maintenance), a mode selection device shall be provided.

Mode selection shall be in accordance with ISO 12100-2:2003, 4.11.10.

The selection of the mode shall be an intentional action. An output signal that indicates the state of the mode selection shall be provided. Application and performance of the signal shall be determined by the risk assessment.

Indication of the selected operating mode shall be provided (e.g. the position of a mode selector, the provision of an indicating light, a visual display indication).

8.5 Safeguards

8.5.1 Selection and implementation of safeguards

Safeguards shall be selected in accordance with ISO 12100-2:2003, 5.2. Safeguards shall be designed to allow interventions to be performed safely within a task zone.

8.5.2 Requirements for the design of guards

Guards shall be designed and constructed according to ISO 14120. If not otherwise specified by requirements from the individual machine or a risk assessment, the following dimensions shall be applied for the IMS.

- For areas where no human access is necessary, the height of fixed and movable guards shall not be less than 1 400 mm.
- For areas where human access is necessary (e.g. load and unload), the height of fixed and movable guards shall not be less than 1 000 mm.
- The gap between guards and the floor shall not be greater than 200 mm.

8.6 Protective measures when safeguards are suspended

8.6.1 General

Tasks requiring manual intervention shall be performed as follows.

- a) They shall be performed from outside the safeguarded space, or when the IMS or part of the IMS is at a standstill.
- b) Where a) is not practicable, then an appropriate mode(s) shall be provided in accordance with 8.4.2. Technical provisions shall be taken to restrict this intervention to certain modes [selector which can be locked, tool or key for opening the door (see Annex D)].
- c) Where b) is not practicable, then a safe position with safe access shall be provided for the operator to perform the task (e.g. process observation within the safeguarded space with adequate risk reduction).

This manual selection to suspend safeguards shall be by a lockable selection device or by other equivalent protective measures (e.g. passwords, access codes for certain control functions).

The suspension of those safeguards may be time limited. When safeguards are suspended, the control system shall prevent a hazardous situation from being initiated from outside the hazard or task zone. IMS automatic mode shall be initiated only from outside the safeguarded space with the relevant safeguards in effect.

In the event of a fault of the suspending function, subsequent suspension shall be prevented until the fault is corrected.

8.6.2 Other protective measures

When the safeguards are suspended, other protective measures shall provide an adequate level of protection as determined by risk assessment. Examples of other protective measures include:

- protective device requiring sustained action (e.g. two-hand control, enabling device);
- reducing speed;
- reducing torque;
- identifying and providing safe position(s) and safe access to perform troubleshooting tasks.

The enabling device shall be of 3-position-type (see IEC 60204-1:2005, 9.2.5.8).

NOTE 1 Safe reduced speed without an enabling device presumes that operators can move away in the case of slow movements. Therefore, in some cases according to a risk assessment, an enabling device may be required even in the case of a safe reduced speed (e.g. narrow space).

NOTE 2 Examples of reduced speeds are less than 10 mm/s for presses, less than 250 mm/s for robots, less than 250 mm/s for non-shearing hazards, and less than 33 mm/s for shearing hazards.

8.6.3 Determining other protective measures

Where the safeguards are suspended to achieve the required functionality of the task zone, the following conditions, as a minimum, shall be analysed for each operating mode:

- a) equipment or a portion thereof that shall be at standstill where the risk assessment indicates intervention shall not be performed with protective devices suspended;
- b) equipment or a portion thereof that should be at standstill where this is practicable for intervention;
- c) equipment that is under the direct control of the operator.

8.6.4 Status indication

Status indication of when safeguards are suspended shall be provided. In addition, to provide the operator with information regarding the suspension of safeguards, one or both of the following shall be provided:

- a) an indication of the status of safety-related functions, circuits and actuators whose suspension can cause hazardous situations;
- b) an indication of the status of essential elements (e.g. status of work in progress, parameters such as position of elements of the equipment, temperature).

8.6.5 Suspension of safeguards of automatically operating equipment

For equipment that is operating automatically, the integrator shall carry out a risk assessment to identify all the hazards and hazardous situations associated with the suspension of safeguards and shall implement appropriate safeguards.

8.7 Muting and blanking

Muting and blanking performance shall be designed in accordance with ISO 13849-1 and/or IEC 62061. Muting and blanking should be installed in accordance with IEC/TS 62046. Muting and blanking shall not result in operator(s) being exposed to hazard(s) (e.g. motion, hot surfaces, noise, laser, radiation, gases).

In the event of a fault of the safety-related part of the muting function, subsequent muting shall be prevented until the fault is corrected.

8.8 Control

8.8.1 General

The following information shall be used to produce both a functional requirements specification and a safety integrity requirements specification of each safety-related control function:

- a) results of the risk assessment for the machine, including all safety functions determined to be necessary for the risk reduction process;
- b) machine operating characteristics, including
 - 1) modes of operation,
 - 2) cycle time(s),
 - 3) environmental conditions, and
 - 4) interaction of person(s) with the machine (e.g. repairing, setting, cleaning);
- c) all information relevant to the safety-related control functions which can have an influence on the safety-related control system design, including, for example
 - 1) a description of the behaviour of the machine that a safety-related control function is intended to achieve or to prevent,
 - 2) all interfaces between the safety-related control functions, and between safety-related control functions and any other function (either within or outside of the machine), and
 - 3) required fault reaction functions of the safety-related control function.

8.8.2 IMS control system

The safety-related control function(s) of the IMS control system shall be determined by the risk reduction strategy and its implementation shall conform to ISO 13849-1, ISO 13849-2 and/or IEC 62061 as appropriate.

The adequate performance level according to ISO 13849-1 or SIL according to IEC 62061 shall be determined by a risk assessment.

8.8.3 Local control

IMS operational requirements shall determine the need for local control.

Where local control is provided, the risk assessment shall determine whether additional protective measures are needed. Where local control is provided, the IMS control system shall be notified of this condition and shall not be able to override the local control. The emergency stop function shall remain operational during local control.

Means of selection/deselection of local control shall not be accessible from the safeguarded space and shall be in close proximity to the machine or subassembly under local control.

8.9 Reset of perimeter safeguarding devices

Manual reset shall be in accordance with ISO 13849-1. Reset of the safeguarding function shall not itself initiate any hazardous conditions.

If it is possible to pass through the detection zone of a protective device into the safeguarded space without continuous detection by additional protective measures, the safeguarding function shall only be reset by a manually operated device intended for this function.

The reset actuator shall be situated outside the hazard zone and shall only be actuated from outside the safeguarded space(s). The reset actuator shall be situated in a safe position from which there is good visibility for checking that no person is within the hazard zone(s).

Where visibility is not complete, the integrator shall provide additional protective measures as follows:

- a) protective measures to ensure that no operator(s) is/are within the hazard zone(s) (e.g. presence-sensing, a special reset system or trapped key systems);
- b) if a) is not practicable, warning signal(s) with time for the signal to be recognized so that either
 - the operator(s) can safely exit the safeguarded space(s), or
 - the operator(s) can actuate a means to stop the reset process and prevent restart from within the safeguarded space(s);
- c) a combination of a) and b).

NOTE One method of accomplishing a special reset solution is to use a second reset actuator. In this case, the reset function will be initiated within the danger zone by the first actuator in combination with a second reset actuator located outside the danger zone (near the safeguard). This reset procedure should be realized within a limited time before the safety-related parts of the control system accept a separate restart command (see ISO 13849-1).

8.10 Start/restart

Start/restart of the IMS or parts of the IMS shall be in accordance with ISO 13849-1.

- Manual start/restart shall require: an intentional action from a control station located outside the safeguarded space, provided that safeguards associated with that part(s) of the IMS are in place, functional, and that all safety-related functions have been reset.
- The actuator(s) shall be located to allow a clear and unobstructed view of the safeguarded space. If a clear view is impractical, a means to ensure that all persons have left the area shall be provided or additional protective measures (e.g. presence-sensing device) shall be provided.

When the risk assessment requires that visual or audible warning device(s) be used, all of the following shall apply:

- a) operation of the start/restart function shall immediately activate the warning device;
- b) the warning device shall be continuously activated until the predetermined warning period has elapsed;
- c) the start/restart function shall be accomplished at the end of the warning period;
- d) a means of preventing start/restart shall be provided inside the safeguarded space; its operation shall override all safeguarding device resets and start/restart functions;

- e) the duration of the warning shall be sufficient to allow the operator(s) to activate the means described above or safely exit the safeguarded space, taking into account the tasks that are performed in the safeguarded space.

NOTE 1 Sufficient time may include the time to disengage from the task, in addition to the time to exit or activate the means.

NOTE 2 For additional requirements for cycle initiation, see ISO 12100-2:2003, 5.2.5.3 or 5.3.2.5.

8.11 Emergency stop

The emergency stop shall be in accordance with IEC 60204-1 and ISO 13850. The span of control of the emergency stop(s) shall be in accordance with 8.2.

The integrator shall design and construct the IMS so that the emergency stop can stop not only the component machine(s) but also all equipment upstream and/or downstream if their continued operation can be hazardous. After the actuation of an emergency stop device for a zone, no hazards shall exist at the interface between this zone and other areas of the system.

All IMS emergency stop devices shall have the same span of control or shall have clearly identified spans of control.

All emergency stop devices for a task zone shall have the same span of control. The span of control may include multiple zones.

Actuation of the emergency stop shall not create additional hazard(s).

Where manual intervention with suspended safeguarding is provided, readily accessible emergency stop devices shall be located within the task zone(s).

8.12 Measures for the escape and rescue of trapped persons

Provisions for the escape and rescue of trapped persons shall be in accordance with ISO 12100-2:2003, 5.5.3.

9 Information for use

9.1 General

The information for use shall be in accordance with ISO 12100-2:2003, Clause 6.

The integrator shall provide technical documentation and an overview of the IMS including, but not limited to:

- a) the IMS functionality;
- b) a description of the intended use and limitations of use of the IMS;
- c) descriptions and/or graphical representations of
 - 1) the IMS layout,
 - 2) equipment locations and orientation,
 - 3) task zones and associated residual risks,
 - 4) spans of control of the various control safety functions and protective devices (e.g., reset of protective devices, enabling devices, emergency stops, control stations, disconnecting means),

- 5) the installed safety distance for the protective devices and the stopping time details,
 - 6) work tasks and task zones, locations and routes to perform the tasks,
 - 7) protective measures,
 - 8) utilities, and
 - 9) material flow;
- d) the documentation relating to the various component machines and associated equipment;
 - e) the modifications made to the protective measures that were originally provided with the component machines.

In addition, the integrator shall obtain the necessary information from the supplier(s) and incorporate it in a logical manner in his own instructions for use.

NOTE See IEC 60204-1:2005, 9.2.5.8, for technical documentation.

9.2 Marking

The IMS shall be marked according to ISO 12100-2:2003, 6.4.

10 Validation of the design

10.1 Validation that the design meets the requirements

As part of the iterative process, the integrator shall determine if the design meets the requirements. If the requirements are not met, then the integrator shall:

- a) modify the IMS layout, functionality and/or limits;
- b) replace and/or modify equipment in order to reduce the risks associated with interventions;
- c) determine new access paths and means;
- d) modify the way in which interventions shall be performed.

10.2 Validation of the protective measures

The integrator shall validate that the selected and applied protective measures adequately reduce the risk.

Annex A (informative)

Examples of integrated manufacturing systems (IMSs)

An integrated manufacturing system can be made with machines and parts of machines as shown in Figure A.1.

Several kinds of integrated manufacturing systems are schematized and their results are presented using forms shown in Figure A.2.

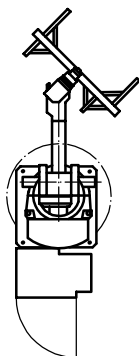
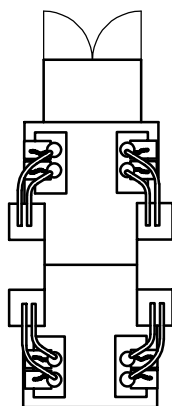

- a) A machine tool, sorting machine b) A robot with its control system c) A conveyor without any control system

Figure A.1 — Examples of machines and parts of machines of IMSs

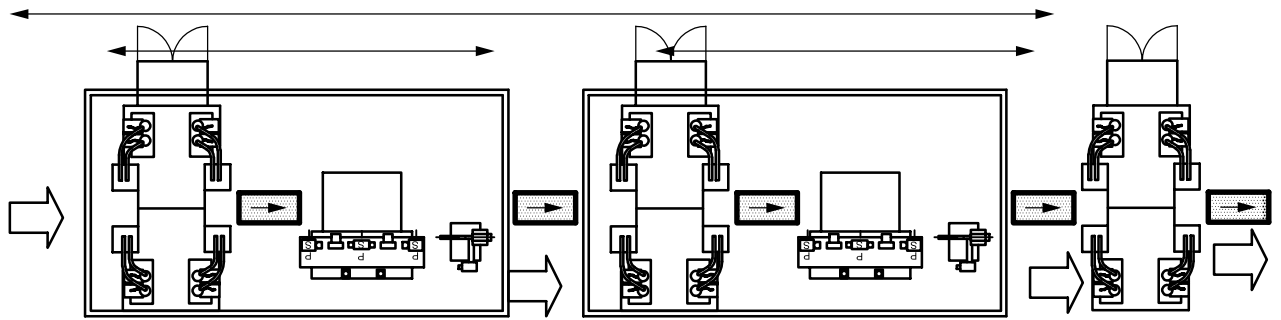

a) Example 1 — Production line for the automotive industry (each machine can be supplied by various suppliers)

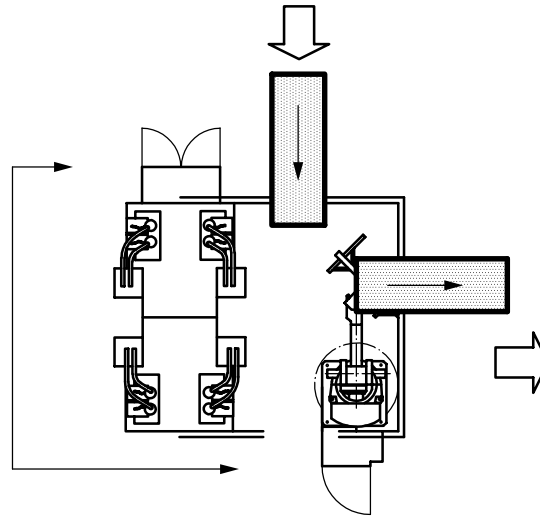

b) Example 2 — Milling machine with a robot to obtain an automatic feeding

Figure A.2 (continued)

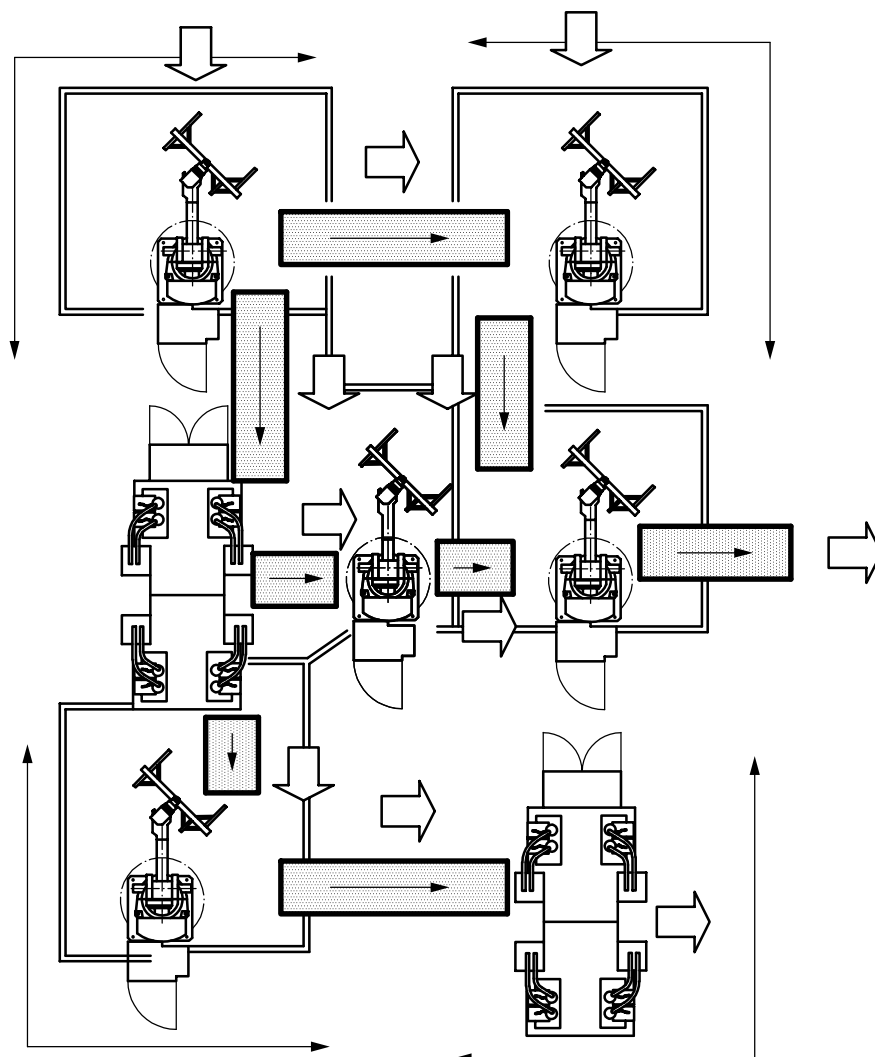

c) Example 3 — Machining and parts distribution IMS

Key

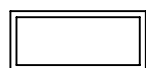

safeguarded space

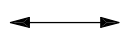

datalink



production flow

} Added value of system integration

Figure A.2 — Examples of IMSs

Annex B (informative)

Flow of information between the integrator, user and suppliers

Table B.1 provides an example of the information flow between the integrator, user and suppliers. The items and subitems are not an all-inclusive list.

Table B.1 — Information flow between the integrator, user and suppliers

Tasks related to safety integration	Information flow	Item	Subitem
IMS functionality	U > I > S	IMS performances	Availability
			Maintainability
IMS limits and constraints	U > I > S	IMS constraints	Batch modifications, shift number
			Products characteristics
			Operator knowledge & qualification
			Environment
			Available surfaces and areas
			Production organization
	S > I	Technical sub-system(s) data	Performances
			Interfaces
			Noise level/vibrations
			Wastes, rejections
Emissions			
Hazard identification	S > I I > S U > I	Hazards linked to IMS configuration	—
Risk assessment	S > I > U	Risks linked to IMS configuration	Residual risks
Key			
I = Integrator; U = User; S = Supplier(s)			

Annex C (informative)

Span of control examples within an IMS

The figures below show examples of how the span of control of an IMS safety system may be implemented.

Figure C.1 shows an IMS composed of five machines and the material-handling system. This IMS has only one zone. Devices which have an associated span of control, and which are considered within this example, are the gate interlocks, emergency stop pushbuttons and the reset buttons. The span of control of these devices is the whole zone. Opening any gate or actuating any emergency stop initiates a stop command of the five machines and the material-handling system (conveyor). Pressing the either reset button resets the safety system for the whole IMS.

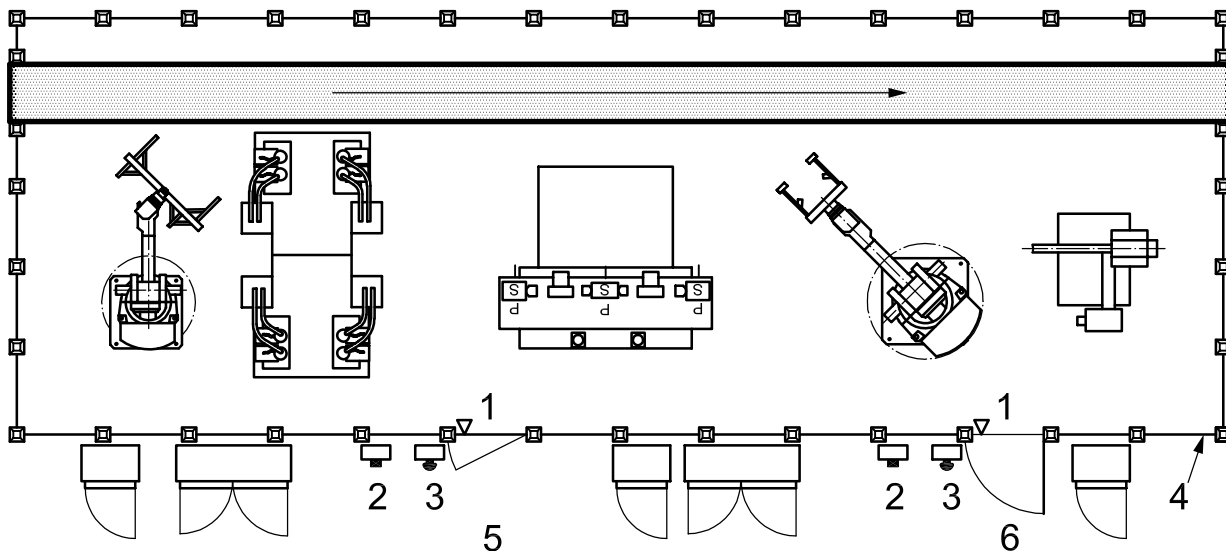

Key

- | | |
|------------------|----------------------|
| 1 gate interlock | 4 perimeter guarding |
| 2 reset | 5 access closed |
| 3 E-stop | 6 access open |

Figure C.1 — IMS composed of five machines and the machine-handling system

Figure C.2 shows the same IMS as in Figure C.1 except the IMS is divided into two zones (zone A and zone B). zone A includes the equipment within zone A and the material-handling equipment (conveyor). zone B includes the equipment within zone B and the material-handling equipment (conveyor). Each zone is associated with its gate interlock, emergency stop and reset devices. The span of control of the gate interlock, emergency stop and reset devices at access 5 is zone A. The span of control of the devices at access 6 and 7 is zone B. In this example, access 7 is open and zone B is stopped, while zone A continues to run.

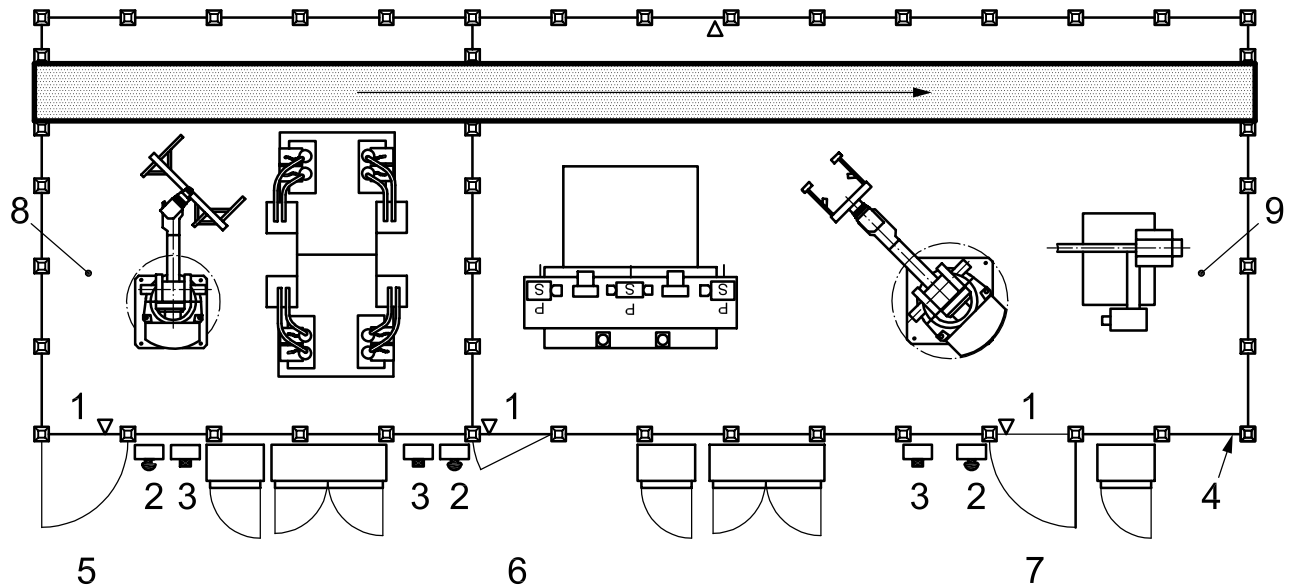

Key

- | | |
|----------------------|-----------------|
| 1 gate interlock | 6 access closed |
| 2 E-stop | 7 access open |
| 3 reset | 8 zone A |
| 4 perimeter guarding | 9 zone B |
| 5 access closed | |

Figure C.2 — IMS as in Figure C.1, but divided into two zones

Figure C.3 shows the same IMS as in Figure C.2 except the IMS has zone C which includes the robot part fixture and presence-sensing. The safety light curtain and safety mat are interconnected with the load fixture and the robot only, not all the equipment in zone A. zone A includes the equipment within zone A and the material-handling equipment (conveyor). zone B includes the equipment within zone B and the material-handling equipment (conveyor).

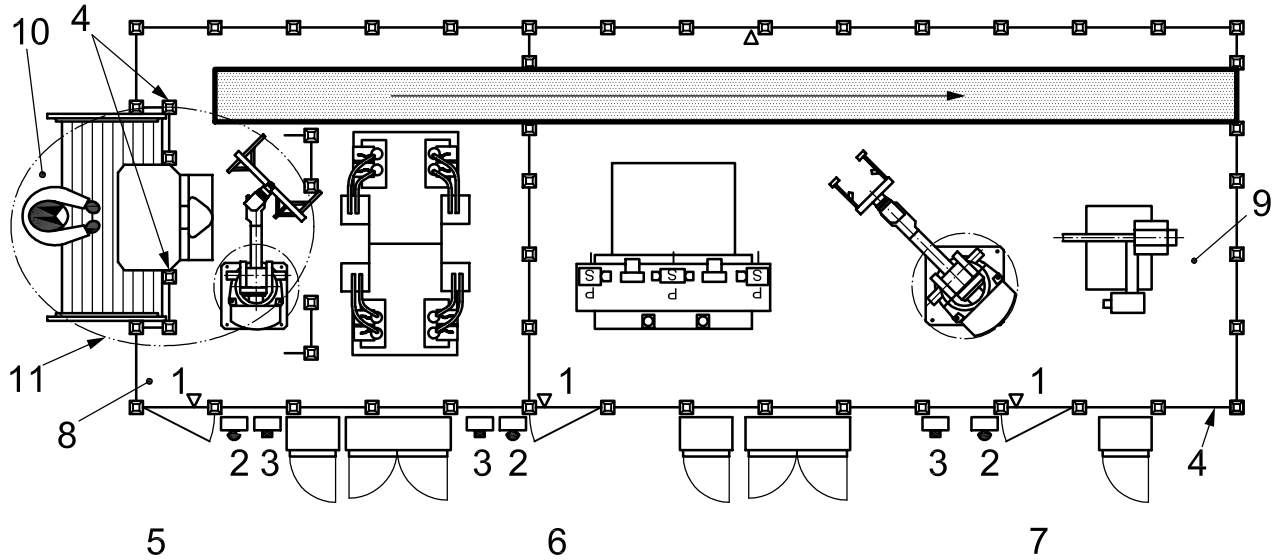

Key

- | | |
|----------------------|--|
| 1 gate interlock | 7 access closed |
| 2 E-stop | 8 zone A |
| 3 reset | 9 zone B |
| 4 perimeter guarding | 10 zone C |
| 5 access closed | 11 presence-sensing installed for continuous detection |
| 6 access closed | |

Figure C.3 — IMS as in Figure C.2, but zone C is equipped with presence-sensing

Figure C.4 shows the same IMS as in Figure C.2, except access 8 allows entry between zones A and B, and the conveyor has separate E-stop devices. The span of control of the gate interlock of access 8 is the machines and robots in zones A and B. The span of control of the devices associated with access 5, 6, 7, and 8 does not include the material handling system (conveyor).

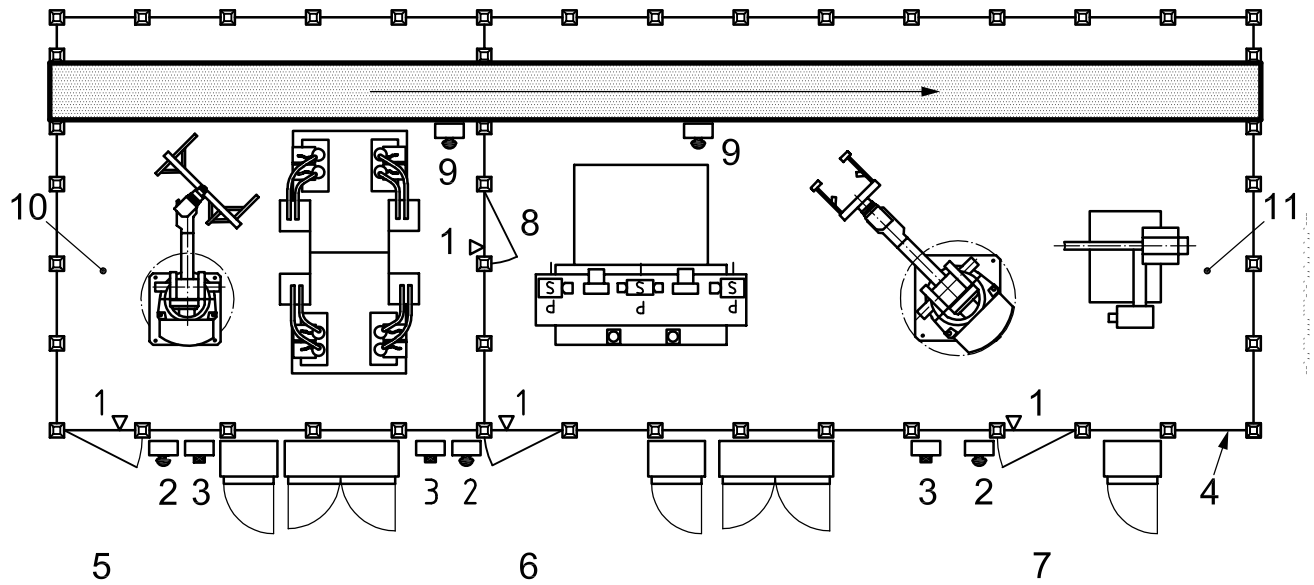

Key

- | | |
|----------------------|--------------------|
| 1 gate interlock | 7 access closed |
| 2 E-stop | 8 access closed |
| 3 reset | 9 conveyor E-stops |
| 4 perimeter guarding | 10 zone A |
| 5 access closed | 11 zone B |
| 6 access closed | |

Figure C.4 — IMS as in Figure C.2, but access 4 allows entry between zones A and B

Annex D (informative)

Temporary observation of the automatic process

D.1 General

Process observation is to be understood as a combination of technical safety measures and requirements for safe behaviour that offers maximum possible protection to the operator by limiting velocities and transverse paths and disconnecting movements that are not required.

Temporary observation of automatic processes should occur, while protective measures are reduced as far as necessary by applying alternative protective measures. Technical safety measures should be carried out in such a way that even foreseeable misuse will be prevented.

This way of action should be the subject of intense contact between the integrator and the future user in order to be able to analyse the requirements for the behaviour of the operator and translate them into action.

If, according to the technology used, a temporary observation of the automatic process of the system or of parts of the system is necessary and if, as an exception, the continuous actuation of an enabling device is not applicable for ergonomic reasons, a concept according to Figure D.1 should be established.

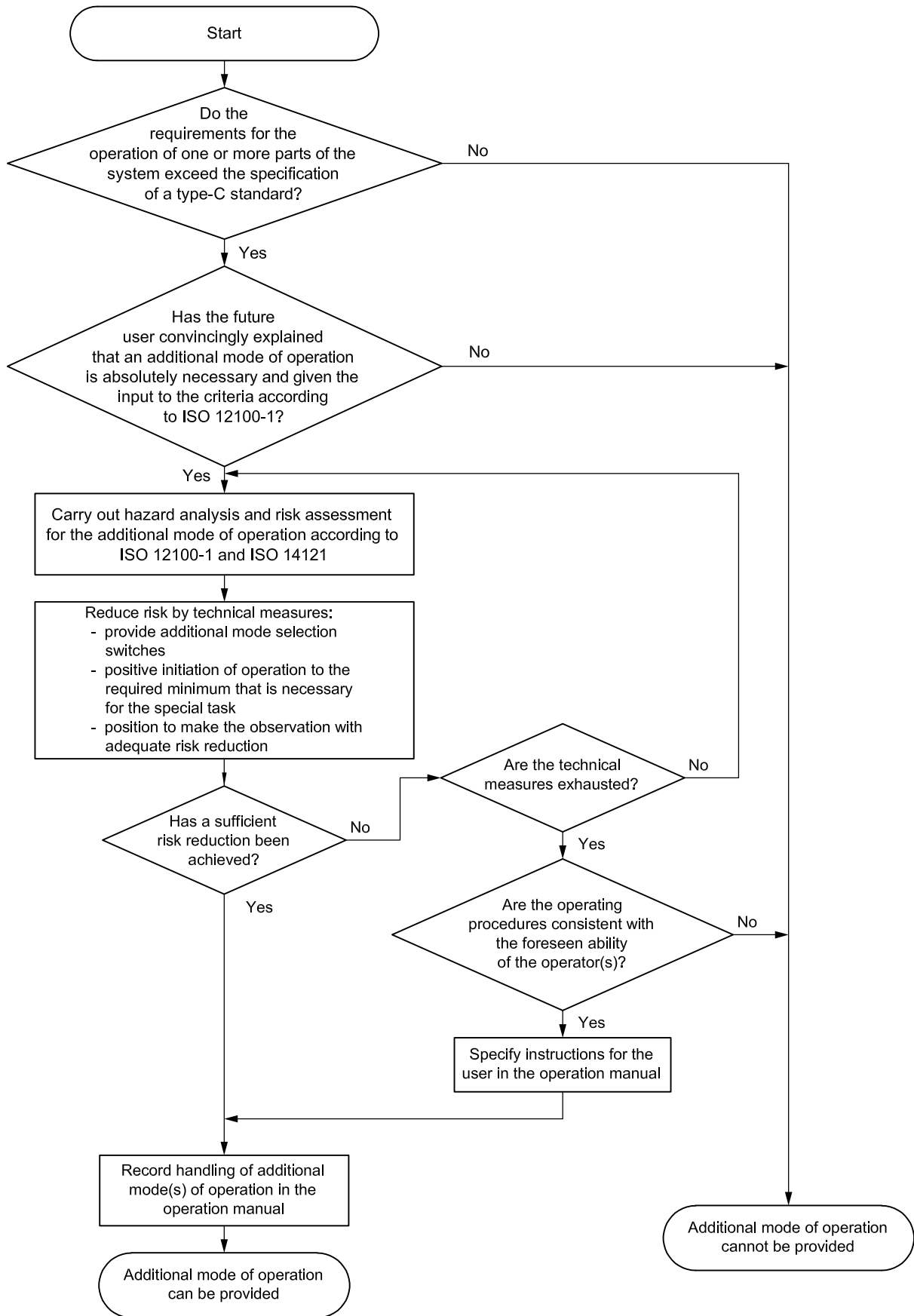

Figure D.1 — Safeguarding during process observation

D.2 Comments on the process observation (see Figure D.1)

- a) Is there a need for “closer” observation of the working process? Can the working process be controlled by the relevant modes of operation laid down in the appropriate type-C standards? Would additional systems, such as video cameras or structure-borne noise devices, be helpful?

Have there been further consultations with the future user? Has the user sufficiently explained that an additional mode of operation is absolutely necessary for the intended production (e.g. due to manufacture of cast unmachined parts with considerably varying tolerances, correction of manufacturing, quality of laser processing)?

- b) Have the results of the consultations and, in particular, the reasons for the additional mode of operation been recorded? Does the application of that additional mode of operation in comparison to normal operation remain restricted to a necessary extent in the scope of the intended use?
- c) The intended use of the IMS with application of the additional mode of operation should be exactly specified and should be included in the technical documentation. For the hazard analysis and the risk assessment, the safety strategy (see Clause 4) should include the intended use. The particular conditions (person close to the process) should be taken into account.
- d) The avoidance of hazards by means of design measures is of highest priority for the risk reduction. Due to the fact that this is difficult to manage, technical safety measures for risk reduction should be considered in particular. The technical measures should be, on one hand, to reduce the risks and, on the other hand, to restrict the additional mode of operation to the largest extent to the required minimum, in order to prevent misuse, for example by
- 1) safe limiting of speed and transverse paths to the required level only,
 - 2) manual restart of moving parts after standstill,
 - 3) safe disconnection of such hazardous movements/axes which are not required for that mode of operation,
 - 4) prevention of automatic tool changing,
 - 5) prevention of pallet changing,
 - 6) prevention of putting the cooling lubricant under high pressure,
 - 7) manual acknowledgement of cooling agent release (eye injury),
 - 8) easy accessibility of devices for stopping in case of emergency (emergency-stop), and
 - 9) authorized access only, e.g. by key switch or password.
- e) If a sufficient risk reduction has been achieved by technical means, the additional mode of operation may be provided.
- f) The iterative process should be continued until the technical measures are exhausted.
- g) If the risk assessment mentioned under point 5 shows that the residual risk is not acceptable, the integrator should check whether the user can make the necessary contribution to the risk reduction by additional means, such as
- 1) particular qualification of employees,
 - 2) providing regular instructions (written proof),
 - 3) personal protective equipment (e.g. protective glasses, protective shoes, wearing of suitable clothing),

- 4) attaching operating instructions concerning the additional mode of operation at the IMS.

If the integrator obtains information that the user is not able to make the above contribution, no additional mode of operation should be provided for the IMS.

- h) If the integrator obtains information that the user is able to make an adequate contribution by additional measures, such measures should be recorded under agreement between the integrator and the user and should be included as a requirement in the operation manual and as markings or warning signs on the IMS.
- i) All information relating to the additional mode of operation should be recorded in the operation manual:
 - 1) intended use;
 - 2) foreseeable misuse;
 - 3) description of operation and functions;
 - 4) measures to be taken by the user according to steps 7 and 8;
 - 5) other requirements concerning maintenance and control.

Bibliography

- [1] ISO 3864-1:2002, *Graphical symbols — Safety colours and safety signs — Part 1: Design principles for safety signs in workplaces and public areas*
- [2] ISO 3864-2:2004, *Graphical symbols — Safety colours and safety signs — Part 2: Design principles for product safety labels*
- [3] ISO 3864-3:2006, *Graphical symbols — Safety colours and safety signs — Part 3: Design principles for graphical symbols for use in safety signs*
- [4] ISO 6385:2004, *Ergonomic principles in the design of work systems*
- [5] ISO 8373:1994, *Manipulating industrial robots — Vocabulary*
- [6] ISO 10218-1:2006, *Robots for industrial environments — Safety requirements — Part 1: Robot*
- [7] ISO/TR 18569:2004, *Safety of machinery — Guidelines for the understanding and use of safety of machinery standards*¹⁾
- [8] IEC/TS 62046:2004, *Safety of machinery — Application of protective equipment to detect the presence of persons*

1) ISO/TR 18569 provides information on other standards that can be used to improve the understanding of this International Standard.

ICS 13.110; 25.040.01

Price based on 36 pages