

Second edition  
2012-07-15

**AMENDMENT 1**  
2014-08-15

---

---

**Gas cylinders — Refillable composite  
gas cylinders and tubes — Design,  
construction and testing —**

Part 2:

**Fully wrapped fibre reinforced  
composite gas cylinders and tubes up  
to 450 l with load-sharing metal liners**

**AMENDMENT 1**

*Bouteilles à gaz — Bouteilles à gaz rechargeables en matériau  
composite et tubes — Conception, construction et essais —*

*Partie 2: Bouteilles à gaz composites entièrement bobinées renforcées  
par des fibres et tubes d'une contenance allant jusqu'à 450 l avec  
liners métalliques transmettant la charge*

*AMENDEMENT 1*



Reference number  
ISO 11119-2:2012/Amd.1:2014(E)

© ISO 2014



**COPYRIGHT PROTECTED DOCUMENT**

© ISO 2014

All rights reserved. Unless otherwise specified, no part of this publication may be reproduced or utilized otherwise in any form or by any means, electronic or mechanical, including photocopying, or posting on the internet or an intranet, without prior written permission. Permission can be requested from either ISO at the address below or ISO's member body in the country of the requester.

ISO copyright office  
Case postale 56 • CH-1211 Geneva 20  
Tel. + 41 22 749 01 11  
Fax + 41 22 749 09 47  
E-mail [copyright@iso.org](mailto:copyright@iso.org)  
Web [www.iso.org](http://www.iso.org)

Published in Switzerland

## Foreword

ISO (the International Organization for Standardization) is a worldwide federation of national standards bodies (ISO member bodies). The work of preparing International Standards is normally carried out through ISO technical committees. Each member body interested in a subject for which a technical committee has been established has the right to be represented on that committee. International organizations, governmental and non-governmental, in liaison with ISO, also take part in the work. ISO collaborates closely with the International Electrotechnical Commission (IEC) on all matters of electrotechnical standardization.

The procedures used to develop this document and those intended for its further maintenance are described in the ISO/IEC Directives, Part 1. In particular the different approval criteria needed for the different types of ISO documents should be noted. This document was drafted in accordance with the editorial rules of the ISO/IEC Directives, Part 2 (see [www.iso.org/directives](http://www.iso.org/directives)).

Attention is drawn to the possibility that some of the elements of this document may be the subject of patent rights. ISO shall not be held responsible for identifying any or all such patent rights. Details of any patent rights identified during the development of the document will be in the Introduction and/or on the ISO list of patent declarations received (see [www.iso.org/patents](http://www.iso.org/patents)).

Any trade name used in this document is information given for the convenience of users and does not constitute an endorsement.

For an explanation on the meaning of ISO specific terms and expressions related to conformity assessment, as well as information about ISO's adherence to the WTO principles in the Technical Barriers to Trade (TBT) see the following URL: Foreword - Supplementary information

The committee responsible for this document is ISO/TC 58, *Gas cylinders*, Subcommittee SC 3, *Cylinder design*.



# Gas cylinders — Refillable composite gas cylinders and tubes — Design, construction and testing —

Part 2:

## Fully wrapped fibre reinforced composite gas cylinders and tubes up to 450 l with load-sharing metal liners

### AMENDMENT 1

This amendment will align the Drop Test of ISO 11119-2 with that of ISO 11119-3

#### 8.5.9 Drop test

##### 8.5.9.1 For cylinders up to and including 50 l water capacity

###### 8.5.9.1.1 Procedure

Two cylinders shall be filled with water to 50 % capacity and fitted with a plug, flush with the end of each cylinder.

Both cylinders shall be dropped twice, in each of the five positions shown in [Figure 2](#), from a minimum height of 1,2 m, on to a steel plate of a minimum of 5 mm thickness. The protective plate shall be sufficiently flat so that the difference in level between any two points on the surface is no more than 2 mm.

One cylinder shall be subjected to the burst test specified in 8.5.4.

The other cylinder shall be subjected to the pressure cycling test specified in 8.5.5.

The parameters that shall be monitored and recorded are the following:

- visual appearance after each drop — record position and dimensions of impact damage;
- parameters specified in test 8.5.4;
- parameters specified in test 8.5.5.

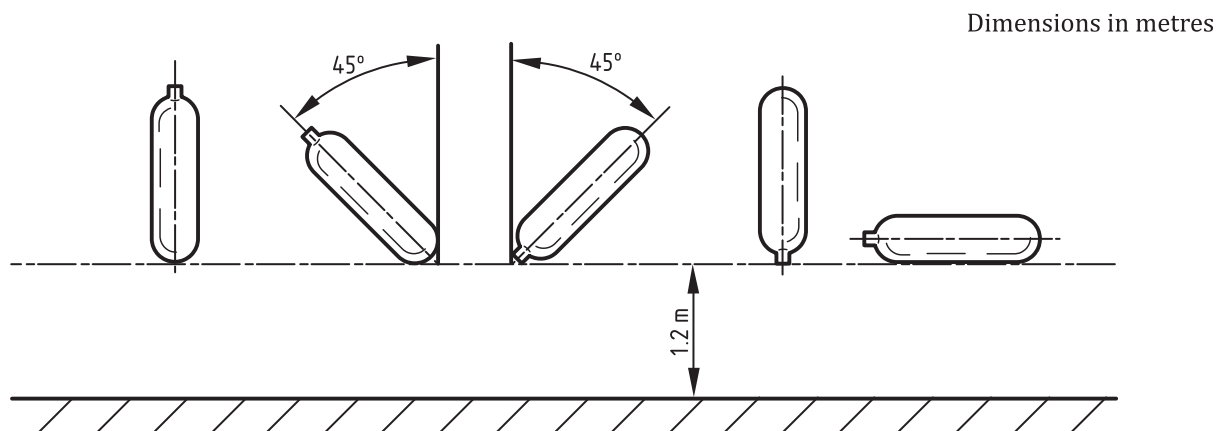

Figure 2 — Drop test

### 8.5.9.1.2 Criteria

First cylinder: burst pressure,  $p_b$ , shall be equal to or greater than 100 % of the minimum burst level required in the burst test (see 8.5.4).

Second cylinder: the cylinder shall satisfy the requirements of the ambient cycle test (see 8.5.5).

### 8.5.9.2 For cylinders over 50 l water capacity

#### 8.5.9.2.1 Procedure

- a) One or more empty cylinders, with sealing device to protect threads and sealing surfaces, shall be drop tested at ambient temperature. The surface onto which the cylinders are dropped shall be a smooth, horizontal concrete pad or flooring.
- b) One cylinder shall be dropped in a horizontal position with the lowest point of the cylinder no less than 1,8 m above the surface onto which it is dropped. One cylinder shall be dropped vertically on one end at a sufficient height above the floor or pad so that the potential energy is 1 220 J, but in no case shall the height of the lower end be greater than 1,8 m. One cylinder shall be dropped at a 45 ° angle onto a dome from a height such that the centre of gravity is at 1,8 m. However, if the lower end is closer to the ground than 0,6 m, the drop angle shall be changed to maintain a minimum height of 0,6 m and a centre of gravity of 1,8 m. The cylinder(s) shall be allowed to bounce on the concrete pad or flooring after the initial impact. No attempt shall be made to prevent this secondary impacting, but the cylinder can be prevented from toppling during the vertical drop test.

#### 8.5.9.2.2 Criteria

The cylinders shall withstand 3 000 pressurization cycles to 2/3 of the test pressure,  $p_h$ , without failure by burst or leakage. The test shall continue for a further 9 000 cycles, or until the cylinder fails by leakage, whichever is the sooner. In either case, the cylinder shall be deemed to have passed the test. However, if failure during this second part of the test is by burst, then the cylinder shall have failed the test.

### Table 1 - Type approval tests

In Table 1:

- replace  $_b$  with  $X^b$
- replace  $_c$  with  $X^c$
- replace  $_d$  with  $X^d$
- replace  $_e$  with  $X^e$



