**Textile machinery — Safety
requirements —**

**Part 1:
Common requirements**

*Matériel pour l'industrie textile — Exigences de sécurité —
Partie 1: Exigences communes*



COPYRIGHT PROTECTED DOCUMENT

© ISO 2016, Published in Switzerland

All rights reserved. Unless otherwise specified, no part of this publication may be reproduced or utilized otherwise in any form or by any means, electronic or mechanical, including photocopying, or posting on the internet or an intranet, without prior written permission. Permission can be requested from either ISO at the address below or ISO's member body in the country of the requester.

ISO copyright office
Ch. de Blandonnet 8 • CP 401
CH-1214 Vernier, Geneva, Switzerland
Tel. +41 22 749 01 11
Fax +41 22 749 09 47
copyright@iso.org
www.iso.org

Contents

	Page
Foreword	v
Introduction	vi
1 Scope	1
2 Normative references	2
3 Terms and definitions	4
4 List of significant hazards	5
5 Safety requirements and/or measures for frequently occurring hazards	6
5.1 General	6
5.2 Safety requirements for the different phases of “life” of a machine	6
5.3 Risk reduction by design and safeguarding	6
5.3.1 Inherently safe design measures	6
5.3.2 Consideration of geometrical factors and physical aspects	6
5.3.3 Reduction of risks by safeguarding	6
5.4 Safety requirements for various hazards	8
5.4.1 General	8
5.4.2 Electrical hazards	8
5.4.3 Mechanical hazards	11
5.4.4 Static electricity	14
5.4.5 Fluid power systems and components	15
5.4.6 Extreme temperatures	15
5.4.7 Noise reduction	16
5.4.8 Lasers	16
5.4.9 Radiation	16
5.4.10 Materials and substances	17
5.4.11 Fire	17
5.4.12 Explosion	18
5.4.13 Ergonomics	18
5.5 Devices for special operation	19
5.6 Access to elevated operating positions and servicing points	20
5.7 Measures for the escape and rescue of trapped persons	20
5.8 Fitting of parts	20
6 Significant hazards and corresponding safety requirements and/or measures for certain machine elements and their combinations	21
6.1 General	21
6.2 Drive and transmission enclosures	21
6.3 Particularly dangerous machine elements	21
6.4 Machine elements which normally do not require safeguarding	23
6.4.1 Low risk machine elements	23
6.4.2 Machine elements out of reach	23
6.5 Rollers	24
6.6 Rotating shafts	30
6.7 Wheels	30
6.7.1 Running wheels	30
6.7.2 Hand wheels	31
6.8 Doors and lids	32
6.8.1 General	32
6.8.2 Opening and closing	32
6.8.3 Locking and unlocking of doors or lids under pressure	32
6.8.4 Entry into machines, vessels or items of plant	33
6.9 Observation windows	34
6.10 Conveyors	34
6.11 Fans	35

6.12	Cutting devices.....	35
6.13	Working platforms and walkways on machines, work areas adjacent to tanks and pits	36
6.14	Radiators or burners for the direct heat treatment of yarn and fabric.....	37
6.15	Devices for steam heating of liquors.....	37
6.16	Liquor preparatory machinery incorporating stirrers.....	38
6.17	Dancing rollers.....	39
6.18	Batching devices.....	39
	6.18.1 General Information.....	39
	6.18.2 Surface-driven batcher.....	40
	6.18.3 Centre batcher.....	42
	6.18.4 Ascending batch winder.....	45
	6.18.5 Equipment for automatic process material change on batching devices.....	46
6.19	Mangles.....	48
6.20	Pilers and plaiters.....	49
6.21	Automatic machines and equipment.....	49
	6.21.1 General.....	49
	6.21.2 Automatic guards.....	49
	6.21.3 Mobile machines, handling devices, operational parts.....	50
	6.21.4 Mobile machines and handling devices which could leave their defined path.....	51
	6.21.5 Floor-mounted and overhead rails (tracks).....	51
	6.21.6 Overhead transport of process material.....	52
6.22	Complex installations.....	52
7	Verification of the compliance with the safety requirements and/or measures	53
8	Information concerning machine use	53
	8.1 Signals and warning devices.....	53
	8.2 Accompanying documents (in particular: instruction handbook).....	53
	8.3 Marking.....	54
	Annex A (normative) Specifications.....	55
	Annex B (normative) Hot surfaces.....	57
	Annex C (normative) Verification methods.....	59
	Annex D (normative) Nip between roller and fabric.....	70
	Annex E (informative) List of machines and equipment used in the textile industry but not within the scope of this part of ISO 11111.....	71
	Bibliography.....	72

Foreword

ISO (the International Organization for Standardization) is a worldwide federation of national standards bodies (ISO member bodies). The work of preparing International Standards is normally carried out through ISO technical committees. Each member body interested in a subject for which a technical committee has been established has the right to be represented on that committee. International organizations, governmental and non-governmental, in liaison with ISO, also take part in the work. ISO collaborates closely with the International Electrotechnical Commission (IEC) on all matters of electrotechnical standardization.

The procedures used to develop this document and those intended for its further maintenance are described in the ISO/IEC Directives, Part 1. In particular the different approval criteria needed for the different types of ISO documents should be noted. This document was drafted in accordance with the editorial rules of the ISO/IEC Directives, Part 2 (see www.iso.org/directives).

Attention is drawn to the possibility that some of the elements of this document may be the subject of patent rights. ISO shall not be held responsible for identifying any or all such patent rights. Details of any patent rights identified during the development of the document will be in the Introduction and/or on the ISO list of patent declarations received (<http://www.iso.org/patents>).

Any trade name used in this document is information given for the convenience of users and does not constitute an endorsement.

For an explanation on the meaning of ISO specific terms and expressions related to conformity assessment, as well as information about ISO's adherence to the WTO principles in the Technical Barriers to Trade (TBT), see the following URL: [Foreword - Supplementary information](#).

The committee responsible for this document is ISO/TC 72, *Textile machinery and accessories*, Subcommittee SC 8, *Safety requirements for textile machinery*.

This third edition cancels and replaces the second edition (ISO 11111-1:2009), which has been technically revised.

ISO 11111 consists of the following parts, under the general title *Textile machinery — Safety requirements*:

- *Part 1: Common requirements*
- *Part 2: Spinning preparatory and spinning machines*
- *Part 3: Nonwoven machinery*
- *Part 4: Yarn processing, cordage and rope manufacturing machinery*
- *Part 5: Preparatory machinery to weaving and knitting*
- *Part 6: Fabric manufacturing machinery*
- *Part 7: Dyeing and finishing machinery*

Introduction

ISO 11111-1 to ISO 11111-7 were prepared simultaneously by ISO/TC 72 and CEN/TC 214, and adopted under the Vienna Agreement in order to obtain identical standards on technical safety requirements for the design and construction of textile machinery.

ISO 11111 as a whole is intended for use by any person concerned with the safety of textile machinery, for example, textile machinery designers, manufacturers and systems integrators. It is also of interest to users of textile machines and safety experts.

This part of ISO 11111 is a type C standard as stated in ISO 12100. The various parts of ISO 11111 deal with significant hazards generated by machines used in the textile industry. The machinery concerned and the extent to which hazards are covered are indicated in the scope of this part of ISO 11111.

When provisions of this type C standard are different from those which are stated in type A or B standards, the provisions of this type C standard take precedence.

For machines or machine equipment not dealt with in the relevant parts of ISO 11111, the designer performs a risk assessment according to ISO 12100 and provides means for reducing the risk from significant hazards. These risk reduction measures that need to be identified by the designer/manufacturer of the machinery by risk assessment are outside the scope of this standard.

This part of ISO 11111 contains a summary of safety requirements and/or measures for frequently occurring hazards of textile machinery (see [Clause 5](#)) which apply whenever referred to in this, or the other parts of ISO 11111.

Significant hazards and corresponding safety requirements and/or measures for certain machine elements (e.g. rollers) and their combination of textile machines are also described (see [Clause 6](#)).

The various parts of ISO 11111 address significant hazards and corresponding safety requirements and/or measures for specific types of textile machines. As far as possible, these are treated by way of reference to [Clauses 5](#) and [6](#) and other cross-references (see general safety requirements), thus reducing considerably the volume by avoiding many repetitions. The standard for a specific textile machine will normally consist of this part of ISO 11111 and the specific part relevant to that machine. ISO 11111-2 to ISO 11111-7 may also contain exceptions or additions to the requirements given in this part of ISO 11111 (see specific safety requirements).

Textile machinery — Safety requirements —

Part 1: Common requirements

1 Scope

This part of ISO 11111 specifies safety requirements for frequently occurring hazards common to the types of textile machinery and the hazards of certain machine elements covered by ISO 11111-2 to ISO 11111-7. The standard series is complemented by the type C standards ISO 9902 (all parts) with respect to noise emission measurement and ISO 23771 with respect to measures for the reduction of noise emissions.

This part of ISO 11111 is applicable to machinery plant and related equipment intended to be used in the textile industry for the following purposes:

- opening, cleaning, blending, carding, preparation subsequent to carding, spinning and other processing of fibres (staple and filament) and other materials to form yarn or nonwoven material (including felts);
- winding, doubling, twisting, texturing, etc., of yarns and the processing of yarns preparatory to weaving and knitting;
- weaving, knitting, lace-making and similar utilization of yarn, etc., to form fabric;
- forming of braid, cord, strand, rope, twine, net, etc., except take-up reels of stranding and laying machinery;
- processing, including the pretreatment, bleaching, dyeing, printing and finishing of fibre, yarn, fabric, braid, cord, etc., and final assembly for dispatch;
- piece-dyeing of made-up goods;
- finishing of warp and weft knitting, including hosiery, other than assembly of the finished product (e.g. sewing);
- manufacturing of carpets by weaving, tufting and other processes.

This part of ISO 11111 applies to all machinery, plant and equipment used during the processes listed above, including equipment to enable automated operation of the machines and processes in either free-standing or complex installations, such as pneumatic fibre transportation, but excluding other transportation between the interfaces of the machines.

NOTE 1 The standard for a specific textile machine will normally consist of two parts: this part of ISO 11111 and the specific part of ISO 11111 relevant to that machine. However, in the case of nonwoven lines, which are covered by ISO 11111-3, ISO 11111-2, ISO 11111-6 and ISO 11111-7 are also to be taken into account.

This part of ISO 11111 does not deal with specific requirements for pressure containment.

NOTE 2 In the EU and EFTA, specific directives for pressure vessels and electromagnetic compatibility, among others, exist.

ISO 11111 (all parts) addresses hazards arising from the transport, assembly and commissioning of the machinery, its adjustment, use, maintenance, decommissioning, dismantling and disposal. Manual loading/unloading is considered to be part of the normal operation of the machinery.

ISO 11111-1:2016(E)

This part of ISO 11111 and the other parts of ISO 11111 are not applicable to machinery, plant and related equipment used for

- manufacturing continuous filaments and man-made fibres up to and including the formation of the first textile package (e.g. continuous filament cheese, staple fibre bale),
- hackling and carding of flax and similar,
- manufacturing of spun-bonded and melt-blown nonwovens,
- forming and making up of garments, household and industrial textile goods, and the pressing and die cutting of nonwoven fabric,
- laundering and dry cleaning of made-up textile goods,
- servicing of textile machines (e.g. machines for card wire mounting, cleaning machines for components of printing machines), and
- certain cutting devices, e.g. log-slitting device, laser cutting, high pressure water jets, ultrasonic device.

NOTE 3 The machines and equipment listed in Annex E are used in the textile industry but are not within the scope of this part of ISO 11111.

This part of ISO 11111 and the other parts of ISO 11111 are not applicable to machinery intended for use in potentially explosive atmospheres.

This part of ISO 11111 and the other parts of ISO 11111 are not applicable to machines which are manufactured before the dates of publication of the International Standards.

2 Normative references

The following documents, in whole or in part, are normatively referenced in this document and are indispensable for its application. For dated references, only the edition cited applies. For undated references, the latest edition of the referenced document (including any amendments) applies.

ISO 4413:2010, *Hydraulic fluid power — General rules and safety requirements for systems and their components*

ISO 9902 (all parts), *Textile machinery — Noise test code*

ISO 10218-1:2011, *Robots and robotic devices — Safety requirements for industrial robots — Part 1: Robots*

ISO 11111-2:2005, *Textile machinery — Safety requirements — Part 2: Spinning preparatory and spinning machines*, amended by ISO 11111-2:2005/Amd 1:2009 and ISO 11111-2:2005/Amd 2:2016

ISO 11111-3:2005, *Textile machinery — Safety requirements — Part 3: Nonwoven machinery*, amended by ISO 11111-3:2005/Amd 1:2009 and ISO 11111-3:2005/Amd 2:2016

ISO 11111-4:2005, *Textile machinery — Safety requirements — Part 4: Yarn processing, cordage and rope manufacturing machinery*, amended by ISO 11111-4:2005/Amd 1:2009 and ISO 11111-4:2005/Amd 2:2016

ISO 11111-5:2005, *Textile machinery — Safety requirements — Part 5: Preparatory machinery to weaving and knitting*, amended by ISO 11111-5:2005/Amd 1:2009 and ISO 11111-5:2005/Amd 2:2016

ISO 11111-6:2005, *Textile machinery — Safety requirements — Part 6: Fabric manufacturing machinery*, amended by ISO 11111-6:2005/Amd 1:2009 and ISO 11111-6:2005/Amd 2:2016

ISO 11111-7:2005, *Textile machinery — Safety requirements — Part 7: Dyeing and finishing machinery*, amended by ISO 11111-7:2005/Amd 1:2009 and ISO 11111-7:2005/Amd 2:2016

ISO 11161:2007, *Safety of machinery — Integrated manufacturing systems — Basic requirements*

- ISO 12100:2010, *Safety of machinery — General principles for design — Risk assessment and risk reduction*
- ISO 13849-1:2006, *Safety of machinery — Safety-related parts of control systems — Part 1: General principles for design*
- ISO 13849-2:2012, *Safety of machinery — Safety-related parts of control systems — Part 2: Validation*
- ISO 13850, *Safety of machinery — Emergency stop function — Principles for design*
- ISO 13851:2002, *Safety of machinery — Two-hand control devices — Functional aspects and design principles*
- ISO 13854, *Safety of machinery — Minimum gaps to avoid crushing of parts of the human body*
- ISO 13855:2010, *Safety of machinery — Positioning of safeguards with respect to the approach speeds of parts of the human body*
- ISO 13857:2008, *Safety of machinery — Safety distances to prevent hazard zones being reached by upper and lower limbs*
- ISO 14118:2000, *Safety of machinery — Prevention of unexpected start-up*
- ISO 14119:2013, *Safety of machinery — Interlocking devices associated with guards — Principles for design and selection*
- ISO/TR 14121-2, *Safety of machinery — Risk assessment — Part 2: Practical guidance and examples of methods*
- ISO 14122-1, *Safety of machinery — Permanent means of access to machinery — Part 1: Choice of fixed means of access between two levels*
- ISO 14122-2, *Safety of machinery — Permanent means of access to machinery — Part 2: Working platforms and walkways*
- ISO 14122-3, *Safety of machinery — Permanent means of access to machinery — Part 3: Stairs, stepladders and guard-rails*
- ISO 14122-4, *Safety of machinery — Permanent means of access to machinery — Part 4: Fixed ladders*
- ISO 14123-1:1998, *Safety of machinery — Reduction of risks to health from hazardous substances emitted by machinery — Part 1: Principles and specifications for machinery manufacturers*
- ISO 14123-2, *Safety of machinery — Reduction of risks to health from hazardous substances emitted by machinery — Part 2: Methodology leading to verification procedures*
- ISO 23771, *Textile machinery — Guide to the design of textile machinery for reduction of the noise emissions*
- IEC 60204-1:2005, *Safety of machinery — Electrical equipment of machines — Part 1: General requirements*
- IEC 60447:2004, *Basic and safety principles for man-machine interface, marking and identification — Actuating principles*
- IEC 61310-1:2007, *Safety of machinery — Indication, marking and actuation — Part 1: Requirements for visual, acoustic and tactile signals*
- IEC 61496-1:2012, *Safety of machinery — Electro-sensitive protective equipment — Part 1: General requirements and tests*
- IEC 61496-2, *Safety of machinery — Electro-sensitive protective equipment — Part 2: Particular requirements for equipment using active opto-electronic protective devices (AOPDs)*
- IEC 61496-3, *Safety of machinery — Electro-sensitive protective equipment — Part 3: Particular requirements for Active Opto-electronic Protective Devices responsive to Diffuse Reflection (AOPDDR)*

ISO 11111-1:2016(E)

IEC 62061:2005+A1:2012+A2:2015, *Safety of machinery — Functional safety of safety-related electrical, electronic and programmable electronic control systems*

EN 614-1+A1, *Safety of machinery — Ergonomic design principles — Part 1: Terminology and general principles*

EN 953+A1, *Safety of machinery — Guards — General requirements for the design and construction of fixed and movable guards*

EN 1005-1+A1, *Safety of machinery — Human physical performance — Part 1: Terms and definitions*

EN 1005-2+A1, *Safety of machinery — Human physical performance — Part 2: Manual handling of machinery and component parts of machinery*

EN 1005-3+A1, *Safety of machinery — Human physical performance — Part 3: Recommended force limits for machinery operation*

EN 1005-4+A1, *Safety of machinery — Human physical performance — Part 4: Evaluation of working postures and movements in relation to machinery*

EN 1127-1, *Explosive atmospheres — Explosion prevention and protection — Part 1: Basic concepts and methodology*

EN 12198-1+A1, *Safety of machinery — Assessment and reduction of risks arising from radiation emitted by machinery — Part 1: General principles*

EN 12198-3+A1, *Safety of machinery — Assessment and reduction of risks arising from radiation emitted by machinery — Part 3: Reduction of radiation by attenuation or screening*

EN 12464-1, *Light and lighting — Lighting of work places — Part 1: Indoor work places*

EN 60825-1, *Safety of laser products — Part 1: Equipment classification and requirements*

3 Terms and definitions

For the purposes of this document, the terms and definitions given in ISO 12100 and EN 953+A1, and the following apply.

NOTE Where values are applicable to terms defined in this clause, these values are indicated in [A.1](#).

3.1 stopping time

time taken by a machine or machine part to reach a stand-still after the signal to stop has been given

3.2 access time

time required to reach a dangerous part from first exposure to that part

3.3 crawl speed

linear or tangential speed of machine elements which is substantially below its normal speed and has a maximum speed and a maximum stopping distance

3.4 reduced running speed

linear or tangential speed of machine elements which is substantially below its normal speed and has a maximum stopping distance

3.5**fence guard**

fixed guard to provide a barrier at a distance which prevents access to a danger zone

Note 1 to entry: It can be either fixed directly to the machine or free-standing or fixed to the floor or constructional elements of the building. Access to the space between the fence guard and the machine is controlled by interlocked doors (see Annex A).

3.6**lap****wrap**

undesired wrapping of the process material around a rotating part of the machine

3.7**normal operation**

entire sequence of the production process, including start-up and incidental cleaning and elimination of routine process faults

EXAMPLE Feeding and removal of process material, threading up, process surveillance, quality tests, removal of fibre fly, mending of broken ends.

3.8**special operation**

procedure and action not included in normal operation

EXAMPLE Setting, tuning, major cleaning, elimination of substantial process faults, maintenance such as the removal of blockages, laps except on spinning, twisting and texturizing machines, re-sewing broken cloth, elimination of rope loops.

3.9**complex installation**

combination of textile machines and service equipment, arranged to work as one integrated production unit, subject to overall control either from a central system or from distributed, communicating systems

3.10**automatic machinery [equipment]**

machinery [equipment] for which systems are employed to govern its operation without further intervention from the operator once the start control has been activated

Note 1 to entry: Such machines may be either free-standing or included in a complex installation. Automatic control can apply to the operational sequence of a machine and its integrated equipment located in a permanent place, and equipment which is mobile, including handling devices (e.g. piecing devices, knotters).

4 List of significant hazards

Significant hazards frequently occurring on textile machinery are considered in [Clause 5](#). Additional significant hazards common to certain machine elements are given in [Clause 6](#). Specific significant hazards for individual textile machines are considered in ISO 11111-2 to ISO 11111-7.

Before using this part of ISO 11111, it is important to carry out a check to ascertain that the specific machine has the significant hazards identified.

NOTE The significant hazards of textile machinery are always considered in conjunction with safety requirements.

5 Safety requirements and/or measures for frequently occurring hazards

5.1 General

This clause contains safety requirements and/or measures to be taken in relation to frequently occurring significant hazards related to textile machinery.

Machinery shall comply with the safety requirements and/or protective measures of this clause, [Clause 6](#) and ISO 11111-2 to ISO 11111-7. In addition, the machine shall be designed according to the principles of ISO 12100 for hazards relevant but not significant, which are not dealt with by this part of ISO 11111.

Where the means of reducing the risk is by the arrangement of the installed machine or a safe system of working the machine, the manufacturer shall give a detailed description of this in the instruction handbook.

Where type B standards that are referred to offer a choice of safety requirements and/or measures having different levels of safety and the selection is not specified in this part of ISO 11111 or in ISO 11111-2 to ISO 11111-7, the manufacturer shall carry out a risk assessment to identify the appropriate level.

5.2 Safety requirements for the different phases of “life” of a machine

The safety requirements given in [Clause 5](#) and in [Clause 6](#), together with the requirements set out in ISO 11111-2 to ISO 11111-7, apply to the use and maintenance of the machine. For the other phases in the life of a machine, mainly see [Clause 8](#).

5.3 Risk reduction by design and safeguarding

5.3.1 Inherently safe design measures

A design concept for the machine and/or its mechanisms which does not inherently create a hazard shall, as far as possible, be adopted.

EXAMPLE The use of pneumatic trunking instead of open lattice conveyors, and the use of pneumatic uncurling devices instead of mechanical uncurling rollers.

For textile machinery, the technical guidelines on inherently safe design in accordance with ISO 12100:2010, 6.2.2, shall apply.

5.3.2 Consideration of geometrical factors and physical aspects

For risk reduction of textile machinery, the geometrical factors and physical aspects given in [Table 1](#) and in accordance with ISO 12100:2010, 6.2.2, shall apply.

Table 1 — Risk reduction by design

Application	Reference
Making machines safe by virtue of	ISO 13854, ISO 13857
— the shape and the relative location of their mechanical component parts,	A.4
— the limitation of the actuating force,	A.1
— the limitation of the mass and/or velocity.	

5.3.3 Reduction of risks by safeguarding

Guards and safety devices used to reduce risks from textile machines shall conform to the requirements of the standards given in [Tables 2](#) and [3](#).

Table 2 — Safety requirements and/or measures for guards

Application	Reference
Guard selection, unless specified in Clause 6 and in ISO 11111-2, ISO 11111-3, ISO 11111-4, ISO 11111-5, ISO 11111-6 and ISO 11111-7	ISO 12100:2010, 6.3.2 EN 953+A1
Guard design and construction	ISO 12100:2010, 6.3.3 EN 953+A1
Guard fastening	EN 953+A1
Guard arrangement, unless specified in Clause 6 and in ISO 11111-2, ISO 11111-3, ISO 11111-4, ISO 11111-5, ISO 11111-6 and ISO 11111-7 ^a	ISO 13857:2008, Tables 1, 4 and 7 and B.1
Guard interlocking, unless specified in Clause 6 and in ISO 11111-2, ISO 11111-3, ISO 11111-4, ISO 11111-5, ISO 11111-6 and ISO 11111-7	ISO 14119:2013, Clauses 5, 6 and 7
Fence guard	A.3
^a The safety distances for guards shall apply to all positions for normal operation as well as for setting, adjustment, maintenance work and elimination of process faults.	

Table 3 — Safety requirements and/or measures for safety devices

Application	Reference
Selection of safety devices, unless specified in Clause 6 and in ISO 11111-2, ISO 11111-3, ISO 11111-4, ISO 11111-5, ISO 11111-6 and ISO 11111-7	ISO 12100:2010, 6.3.2
Technical characteristics of safety devices	ISO 12100:2010, 6.3.3.3 IEC 61496-1
Positioning of safety devices, unless specified in Clause 6 and in ISO 11111-2, ISO 11111-3, ISO 11111-4, ISO 11111-5, ISO 11111-6 and ISO 11111-7 ^a	ISO 13855:2010, Clause 7
Interlocking (with and without guard locking): — selection — design	ISO 14119:2013, Clause 7 ISO 14119:2013, Clauses 5 and 6 IEC 61496-1
Electro-sensitive protective equipment: ^{b, d} — arrangement	IEC 61496-1 ISO 13855:2010, Clause 6
Active opto-electronic protective devices (AOPDs): ^{b, d} — arrangement — safety distance (upper and lower limbs)	IEC 61496-2 ISO 13855:2010, Clause 6 ISO 13857
Active opto-electronic protective devices responsive to diffuse reflection (AOPDDR): ^{b, d} — arrangement — safety distance (upper and lower limbs)	IEC 61496-3 ISO 13855:2010, Clause 6 ISO 13857
^a The safety distances for safety devices shall apply to all positions for normal operation as well as for setting, adjustment, maintenance work and elimination of process faults.	
^b The type selected in accordance with IEC 61496-1 shall be consistent with the required performance level (PL) or safety integrity level (SIL) of the safety-related part of the control system, as defined in ISO 13849-1:2006, 4.2.2 (or IEC 62061:2005+A1:2012+A2:2015, 5.2.4.).	
^c The type selected in accordance with ISO 13851 shall be consistent with the required performance level (PL) or safety integrity level (SIL) of the safety-related part of the control system, as defined in ISO 13849-1:2006, 4.2.2 (or IEC 62061:2005+A1:2012+A2:2015, 5.2.4.).	
^d Sensitive protective equipment (SPE) in accordance with ISO 12100:2010, 3.28.5.	

Table 3 (continued)

Application	Reference
Pressure-sensitive mats and floors ^d	EN 1760-1
Pressure-sensitive edges and bars ^d	EN 1760-2
Pressure-sensitive bumpers, plates, wires ^d	EN 1760-3
Two-hand controls:	ISO 12100:2010, 3.28.4 IEC 60204-1:2005, 9.2.6.2
— selection ^c	ISO 13851:2002, Clause 4 and Annex B
— arrangement	ISO 13855:2010, Clause 8
Hold-to-run control devices (touch control, biased-off switch)	ISO 12100:2010, 3.28.3 IEC 60204-1:2005, 9.2.6.1
Limited movement control device	ISO 12100:2010, 3.28.9
<p>^a The safety distances for safety devices shall apply to all positions for normal operation as well as for setting, adjustment, maintenance work and elimination of process faults.</p> <p>^b The type selected in accordance with IEC 61496-1 shall be consistent with the required performance level (PL) or safety integrity level (SIL) of the safety-related part of the control system, as defined in ISO 13849-1:2006, 4.2.2 (or IEC 62061:2005+A1:2012+A2:2015, 5.2.4).</p> <p>^c The type selected in accordance with ISO 13851 shall be consistent with the required performance level (PL) or safety integrity level (SIL) of the safety-related part of the control system, as defined in ISO 13849-1:2006, 4.2.2 (or IEC 62061:2005+A1:2012+A2:2015, 5.2.4).</p> <p>^d Sensitive protective equipment (SPE) in accordance with ISO 12100:2010, 3.28.5.</p>	

5.4 Safety requirements for various hazards

5.4.1 General

The principles of risk elimination, reduction by design and safeguarding in accordance with [5.3](#) shall apply.

5.4.2 Electrical hazards

5.4.2.1 General

Hazards

- Electrical, generated by contact of persons with live parts and parts which have become live under fault conditions (e.g. insulation fault or failure), or by approach of persons to live parts, especially in the high voltage range.
- Mechanical, due to failure of electrical equipment, e.g. failure of the control system, unexpected restart.

5.4.2.2 General safety requirements for electrical equipment

Hazards arising from electrical equipment shall be reduced by the application of safety requirements selected from the clauses of IEC 60204-1 in accordance with [Table 4](#).

Table 4 — Safety requirements for electrical equipment of machines

Electrical hazards	Reference
	IEC 60204-1:2005
Electric shock	Clauses 6 and 8
Over-current, over-speed and overload	Clauses 7 and 8
Environmental influences	Clause 4
Restart after voltage drop or supply interruption	7.5
Accessibility, layout and identification of control equipment	Clauses 10, 11 and 16
Ergonomics for manual operation	Clauses 10 and 11
Cabling and wiring	Clauses 12 and 13
Accessories and lighting	Clause 15
Documentation and instruction handbook	Clause 17
Testing	Clause 18

5.4.2.3 Specific safety requirements for control systems and devices

Hazards arising from the control system shall be reduced by the application of safety requirements selected from the clauses of IEC 60204-1 or from other relevant standards in accordance with [Table 5](#).

Table 5 — Safety requirements for control systems

Application	Reference
Design of control system	ISO 12100:2010, 6.2.11
Control circuits and functions	IEC 60204-1:2005, Clause 9
Control interfaces	IEC 60204-1:2005, Clause 10
Programmable electronic equipment	ISO 13849-1 or IEC 62061
Control gear	IEC 60204-1:2005, Clause 11
Fault exclusion/proven components	ISO 13849-2:2012, Clause 7
Required Performance Level (PL) or Safety Integrity Level (SIL)	ISO 13849-1 or IEC 62061
Categories of resistance to faults	ISO 13849-1:2006, Clause 6
Control devices	IEC 60204-1:2005, Clause 10
Safety signals, symbols and signs (visual, acoustic and tactile)	IEC 61310-1:2007, Clauses 5 to 8
Arrangement of control devices	ISO 12100:2010, 6.2.8 and 6.2.11.8
Actuating principles	IEC 60447:2004

If in [Clause 6](#) or in ISO 11111-2, ISO 11111-3, ISO 11111-4, ISO 11111-5, ISO 11111-6 and ISO 11111-7 a performance level (PL) in accordance with ISO 13849-1 or a safety integrity level (SIL) in accordance with IEC 62061 has not been selected, a PL = c or SIL = 1 shall at least be used for the safety-related parts of control systems.

The adoption of a lower level than performance level PL = c or safety integrity level SIL = 1 shall be based on a risk assessment in accordance with ISO 13849-1:2006, Annex A or IEC 62061:2005+A1:2012+A2:2015, Annex A.

Fault exclusions for components used in systems required to comply with a specified performance level shall be in accordance with ISO 13849-2.

5.4.2.4 Specific safety requirements for starting and stopping

Hazards arising from starting and stopping shall be reduced by the application of safety requirements selected from the clauses of IEC 60204-1 or from other relevant standards in accordance with [Table 6](#).

Table 6 — Safety requirements for starting and stopping

Application	Reference
Starting	ISO 12100:2010, 6.2.11.2 and 6.2.11.3
Stopping ^a	IEC 60204-1:2005, 9.2.2
Unexpected start-up	ISO 14118:2000, Clauses 5 and 6
Isolation from energy sources	ISO 12100:2010, 6.3.5.4 IEC 60204-1:2005, Clause 5
Start-up by inadvertent actuation	5.4.2.4 a) and ISO 12100:2010, 6.2.11.8
Observation of danger zones from main control position	5.4.2.4 b)
Start-up by unauthorized persons	5.4.2.4 b)
Automatic restart after process interruption	5.4.2.4 c)
Start-up after interruption of power supply	IEC 60204-1:2005, 7.5
Emergency stopping	5.4.2.4 d) ISO 12100:2010, 6.3.5.2 ISO 13850 IEC 60204-1:2005, 10.7 and 10.8 ISO 11161

^a Each workstation of the machine shall be provided with a control device for generating a safe normal stop in accordance with IEC 60204-1; stop category 0 or 1. If, additionally, a stop control is required to generate an operational stop (in accordance with IEC 60204-1; stop category 2), the stop condition shall be monitored to detect faults to prevent an unintended restart.

- a) Requirements concerning start-up by inadvertent actuation shall be satisfied by any of the following:
 - 1) control switch button slightly recessed in relation to the surrounding surface;
 - 2) covered control switch;
 - 3) control switch requiring more than one operation (e.g. pressing and turning);
 - 4) control switch located beneath a hinged flap;
 - 5) control switch with lock in the off position;
 - 6) two-button start control.
- b) Textile machinery plant or systems which cannot be totally observed from the main control position (e.g. automated blow room machinery, continuous carpet dyeing and finishing lines, nonwoven production lines), or in the proximity of which communication is difficult (owing, in particular, to loud noise, e.g. speed frames, weaving machines, braiding machines) shall, in addition to the measures specified in ISO 12100:2010, 6.2.8, be provided with individual key-operated control switches or similar devices (e.g. lockable isolator switches) to prevent the equipment being started up by unauthorized persons. In order to observe the danger zones from the control position, mirrors, camera screens and other viewing auxiliary means may be used or the control console may be provided in an elevated position.

NOTE 1 “Start-up by unauthorized persons” means switching on a machine by a person neither deputed nor directed so to do.

NOTE 2 For interconnected machines (integrated manufacturing systems), the safety requirements given in ISO 11161 can be used.

- c) Where automated process fault elimination devices are fitted to a machine, automatic restart after process interruption may only be possible when guards and safety devices are in position and activated. Where there is a residual risk, the operator shall be warned by a warning signal in accordance with IEC 61310-1 before restart. The warning device shall be positioned close to the danger zone.
- d) Where a warning signal is used to warn against the start of a machine and to allow persons in danger to reach a safeguarded place within sufficient time, the start/restart shall be in accordance with ISO 11161:2007, 8.8 unless otherwise indicated in ISO 11111-2, ISO 11111-3, ISO 11111-4, ISO 11111-5, ISO 11111-6 and ISO 11111-7.

5.4.3 Mechanical hazards

Hazards

[Table 7](#) lists, illustrates and describes hazards associated with textile machinery, from, for example, machine elements or transmission parts.

Safety requirements

Mechanical hazards arising from the machine shall be reduced by the application of safety requirements in accordance with [5.3](#).

Table 7 — Mechanical hazards

Hazard	Illustration examples ^a	Description
Crushing		<p>Generated when</p> <ul style="list-style-type: none"> — two movable parts are moving towards each other, or — one movable part is moving towards a fixed part. <p>(For minimum gaps, see ISO 13854.)</p>
Shearing		<p>Generated when</p> <ul style="list-style-type: none"> — two movable parts move closely past each other, or — one movable part moves closely past a fixed part.
Cutting or severing		<p>Generated when stationary or movable parts have sharp edges (e.g. blades, knives).</p>
Entanglement		<p>Generated when shafts or shaft ends, rotating or traversing parts with projecting edges, teeth, cotters, screws, bolts, oiler cups, etc., can entangle clothing, hair and/or body parts.</p>
<p>^a In the figures, the smaller arrow indicates the moving direction, while the larger one indicates the danger area.</p>		

Table 7 (continued)

Hazard	Illustration examples ^a	Description
Drawing-in and trapping		<p>Generated when</p> <ul style="list-style-type: none"> — two-counter-rotating parts are in either direct or close contact with each other, — rotating parts are in contact with tangential parts or process materials (e.g. rollers and process materials, conveyor belts and pulleys, chains and sprockets), or — rotating parts are close to a fixed surface.
Impact		<p>Generated when a moving part can strike an exposed person (e.g. traversing parts, beaters, flyers, winches).</p>
Stabbing or puncture		<p>Generated when stationary or moving parts have pointed edges or tips.</p>
Friction or abrasion		<p>Generated when contact is made with the surface of a rapidly moving part or with a moving part having an abrasive surface (e.g. card clothing).</p>

^a In the figures, the smaller arrow indicates the moving direction, while the larger one indicates the danger area.

Table 7 (continued)

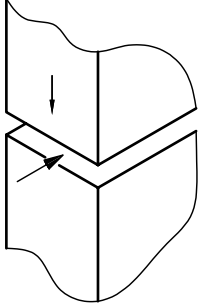
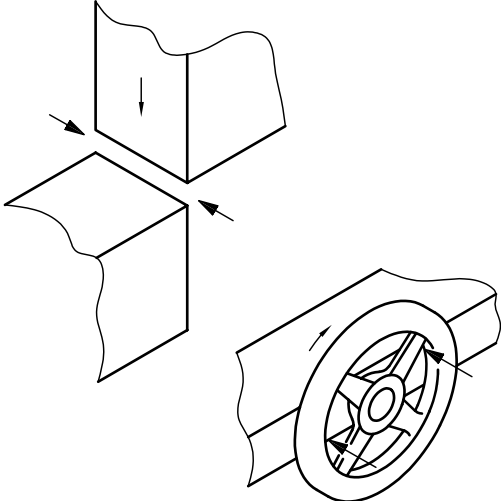
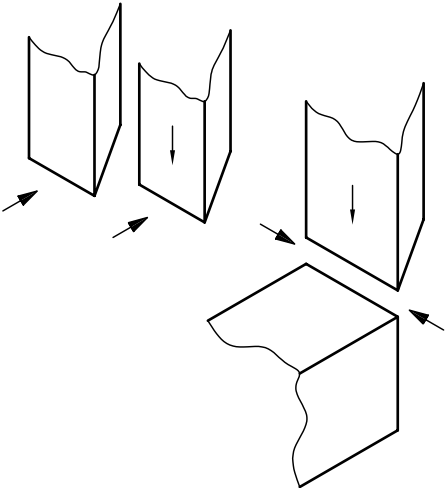
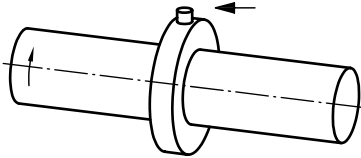
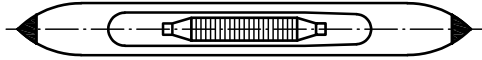
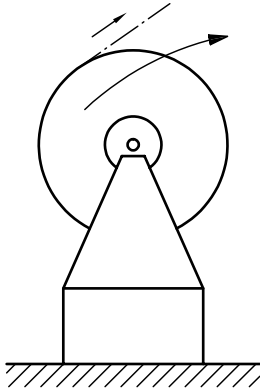
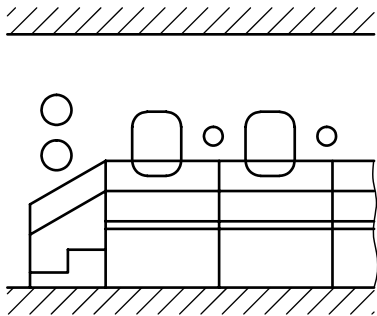
Hazard	Illustration examples ^a	Description
Ejection of parts (including process material falling)		Generated when a moving part of machinery or process material leaves its defined path or is thrown out of the machine (e.g. tubes, bobbins, shuttles or beams).
Overturning, unexpected loss of stability		Generated when a part of a machine or the machine itself can overturn or become unfastened from its mountings due to inherent lack of stability or rapid start-up of certain processes (e.g. running off process material from A-frames).
Slip, trip and fall		Generated when <ul style="list-style-type: none"> — surfaces of walkways, work platforms, staircases, ladders, etc., are slippery, — floor surfaces are uneven or parts are projecting, — process material, its carrier (e.g. tubes, bobbins, beams) have fallen onto or are left lying on the floor, or — no rail is present.

^a In the figures, the smaller arrow indicates the moving direction, while the larger one indicates the danger area.

5.4.4 Static electricity

Hazards

Static electricity can be unintentionally generated in the course of the production process (e.g. carding fibre) and result in the discharge of sparks, which can cause fire or explosion, or shocks to persons contacting parts charged by process materials.

Safety requirements

Appropriate measures to prevent the build-up of static electricity or to discharge shall be provided.

To prevent the generation of static electricity, suitable materials from which the machine is constructed shall be used.

To discharge static electricity, one of the following measures or any combination thereof shall be taken:

- a) providing an earthed protective conductor on the conductive parts of the machinery or plant. The resistance (impedance) of the conductors shall be chosen in dependence on the discharge properties requested. A conductor could also be conductive materials preventing electrostatic charge and may discharge available charges to the conducting part of the machine or plant, e.g. conductive bearings or seals;
- b) fitting static eliminators in appropriate positions on machinery;

- c) providing information in the instruction handbook on avoiding static electricity. This information can be given e.g. by indicating the minimum humidity to be provided by the air-conditioning system or by providing instructions on how to avoid over-drying.

NOTE Detailed information for the avoidance of static electricity is given in CENELEC Report R 044-001:1999.

5.4.5 Fluid power systems and components

Hazards

Generated when fluid under pressure is ejected from or leaks out of tubes, fittings, nozzles, vessels and hoses (e.g. compressed air, hydraulic oil).

Safety requirements

The safety requirements and/or measures given in ISO 12100:2010, 6.2.10, in ISO 4413:2010, 5.2 (hydraulic) and in ISO 4414:2010, 5.2 (pneumatic) shall apply.

5.4.6 Extreme temperatures

5.4.6.1 Hot surfaces and flames

Hazards

Generated by contact of persons with hot surfaces of machines or vessels used or with flames (e.g. singeing machines) or by proximity radiation heaters (e.g. infrared heaters). The hot surfaces result from the incorporation of purposely heated parts to directly assist and further the production process (i.e. heated rollers, tubes, burners or plates), or are generated in the course of the production process, even extending to the entire vessels themselves, due to the hot liquors or steam they contain.

Safety requirements

Textile machines shall be designed so as to reduce the risk of burn injury caused by intended or non-intended contact with or proximity to machine parts, process material at high temperatures or to flames.

The surface temperatures of machine parts, insulation, shields or guards shall not exceed the values given in Annex B.

Where, for technical reasons, these limits cannot be achieved, a warning shall be given on the machine and information shall be given in the instruction handbook concerning instruction and training of operators and the use of personal protective equipment.

5.4.6.2 Hot processing materials — Liquor or steam

Hazards

Generated by splashing or spilling of hot fluids, such as water, steam etc., out of vessels, fittings and sample pots.

Safety requirements

Machines or vessels containing hot liquor or steam shall be designed to prevent any risk of scalding owing to splashing or spilling, including those from thermal reactions caused by chemicals (e.g. when hydrosulfite is added to a liquor).

This shall be achieved by a selection of one or more of the following means:

- providing means for limitation of temperature during the addition of chemicals;
- providing means for limitation of liquor level during the addition of chemicals;
- indirect steam heating rather than direct steam heating;
- provision of atmospheric vessels with interlocked doors or lids to prevent adding chemicals at high temperatures or liquor level;
- providing deflection devices, or a catch pan, spillway or similar device to prevent scalding of the operator by splashing or spilling liquor;
- locating steam control devices or valves in a safe place or, when to be fitted by the user in the steam supply pipe, placing a warning in the instruction handbook.

5.4.7 Noise reduction

Hazards

Hearing loss and physiological disorders (as occupational diseases), interference with speech communication and acoustic signals (as source of accidents), generated from fast-rotating machine elements (e.g. spindles, flyers, rotors, texturing devices, gears), fast traversing machine elements (e.g. thread guides, needle bars, sleys, shed forming equipment), flowing fluids (e.g. suction devices, direct steam heating) and other loud sources on the machines.

Safety requirements

The requirements according to ISO 23771 shall apply.

5.4.8 Lasers

Hazards

Burning generated by contact with lasers (e.g. monitoring devices).

Safety requirements

The requirements of EN 60825-1 shall apply.

5.4.9 Radiation

Hazards

Radiation damage generated by non-ionizing or ionizing radiation [e.g. radio frequency (high-frequency dryers), infrared-radiation (infrared dryers) or β -rays (monitoring devices)].

Safety requirements

The requirements of EN 12198-1+A1 and EN 12198-3+A1 shall apply.

5.4.10 Materials and substances

Hazards

Various materials and substances processed, used, liberated or exhausted in the textile industry can result in a foreseeable risk from contact, inhalation or ingestion. Included are dusts, fluids, gases, mists and fumes having a harmful, toxic, biological corrosive and/or irritant effect (e.g. asbestos, cotton dust, solvents, certain dyestuffs and chemicals). These are generated, for example, in spinning preparation, sizing, waxing, bleaching, dyeing and various finishing processes.

Safety requirements

To reduce the foreseeable risk, textile machines shall be equipped and/or designed so that hazardous substances, including dust from fibre, can be confined, extracted and/or reduced to a non-hazardous level (e.g. by totally enclosing machines, sealing any doors or covers, and/or exhaust ventilation systems which provide a negative pressure). Where machinery is not enclosed during normal operation, the devices for confinement or extraction shall be as close as possible to the source of emission.

Furthermore, the safety requirements and/or measures given in ISO 14123-1:1998, Clause 6, shall apply.

In the instruction handbook, the machinery manufacturer shall state those materials or substances for which the machine has or has not been specifically prepared.

5.4.11 Fire

Hazards

Fire hazards can be generated in a variety of textile processes (e.g. in spinning preparation, spinning, weaving, cropping or shearing), caused by combustion of fibre, fly or fibre dust, in particular from cotton or bast fibre, through contact with hot bearings, sparks resulting from metallic impurities, electrical sparks, and in various finishing processes from the overexposure of the process yarn or fabric to hot surfaces, radiators or burners. Fire poses the risk of burns or inhalation of toxic fumes.

Safety requirements

Textile machines shall be designed and constructed to reduce the risk of fire and to counter and extinguish fire once generated.

In case fire is a significant hazard (see ISO 11111-2, ISO 11111-3, ISO 11111-4, ISO 11111-5, ISO 11111-6 and ISO 11111-7), measures from the following list shall be selected, with preference for the measures under item a):

- a) Measures to avoid the generation of fire:
 - 1) automatic detection and removal of metallic impurities;
 - 2) use of spark-proof materials;
 - 3) information on maintenance procedures to reduce the risk of overheating of machine elements (e.g. due to dust accumulation);
 - 4) separation of the process material from hot surfaces, burners or radiators, shielding of burners or radiators when the machine comes to rest;
 - 5) use of devices to detect wrapping of fibrous material;
 - 6) prevention of dust accumulation.

- b) Measures to counter and extinguish fire once generated:
- 1) provision of flame or smoke detectors together with automatic fire extinguishers as an integral part of the machine;
 - 2) provision of information in the instruction handbook regarding the need to install either fixed automatic fire extinguishers (e.g. sprinkler systems) or hand-operated fire extinguishers in the building;
 - 3) description of safe procedure for extinguishing in the instruction book;
 - 4) providing openings allowing secure extinguishing.

5.4.12 Explosion

Hazards

Mechanical or thermal, generated by ignition of explosive substances processed, used or exhausted (e.g. flammable solvents, fibre dust) or by fast-running chemical reactions (e.g. decomposition of hydrogen peroxide).

Safety requirements

Textile machines shall be designed and constructed to avoid any foreseeable risk of explosion.

Means to reduce the accumulation of fine dust include

- enclosures and exhaust ventilation systems, which should be as in [5.4.10](#), and
- information given in the instruction handbook regarding cleaning schedules to prevent the accumulation of fine dust in dangerous quantities and also precautions which apply when the workroom air-conditioning system is inoperative.

Means to avoid or counter the risks of an explosive atmosphere from flammable liquids and dusts are given in EN 1127-1.

5.4.13 Ergonomics

Hazards

Neglect of ergonomic principles leads to excessive or repetitive efforts. Impairment to health and the risk of accident might be the result.

Safety requirements

- a) Textile machines shall comply with the ergonomic principles given in ISO 12100, EN 614-1+A1, EN 1005-1+A1, EN 1005-2+A1, EN 1005-3+A1 and EN 1005-4+A1.
- b) The lighting required for the operation of textile machinery in accordance with EN 12464-1 shall be ensured. This can be realized by providing installation instructions in the instruction handbook with respect to the lighting required in the installation area or, when necessary, by the integration of lighting into the textile machinery. As far as possible, the instructions shall indicate areas which cannot be sufficiently lit by ambient lighting and for which lighting suitable for specific working areas is required.
- c) Operation of textile machinery generally requires a standing position. If operation in a sitting position is planned, the working area shall be designed either for attachment of seats (including the use of suitable chairs) or the seat shall be an integral part of the machine. In this case, the seat shall offer safe holding and its distance to the operating parts shall be adaptable to the operator.

5.5 Devices for special operation

Hazards

Special operations (see [3.8](#)) frequently result in hazards which deviate from those occurring under normal operation, since such operations may have to be performed with the machine running and the guards not in place and/or the safety devices inoperative.

Safety requirements

The safety requirements according to [Table 8](#) shall apply.

Table 8 — Safety requirements for special operations

Application	Reference
	ISO 12100:2010
Principles relating to manual control	6.2.11.8
Selection of control and operating modes	6.2.11.10
Control mode for special operation	6.2.11.9
Access to danger zone during special operation	6.3.2
Other items	This part of ISO 11111
Operation at standstill	6.3.4.2

Adjustment, lubrication and maintenance points shall be located outside danger zones, or warning notices shall be fixed and details included in the information for use.

The machine shall be so designed that adjustments, tuning and elimination of minor process faults can be easily and safely carried out. Wherever possible, maintenance, repair, setting, cleaning, servicing operations and dangerous elimination of process faults shall be carried out while machinery is at a standstill and totally isolated from all dangerous sources of motive power.

If this work cannot be carried out with the machinery at standstill, the guards and safety devices shall remain activated. If for technical reasons this cannot be achieved, one of the following measures shall be taken in the order given.

- a) Devices shall be provided to operate machines or parts by hand with the machines totally isolated (e.g. hand wheels, levers).
- b) Hold-to-run controls or three-stage controls together with a crawl speed (see [Table A.1](#)) shall be provided, unless otherwise stated in ISO 11111-2 to ISO 11111-7. Release of the control actuator or the further pushing in of a three-stage control actuator shall lead to a stop of category 0 or 1 (IEC 60204-1).

NOTE Three-stage controls operate in a similar manner to hold-to-run controls. The machine is started when the control actuator button is pushed to the operating position. The machine is stopped as soon as the button is released or pushed further in.

- c) Limited movement control devices shall be provided which allow limited movement of the machine or part when actuated. Each step shall be of the minimum achievable within a maximum of 100 mm unless otherwise stated in ISO 11111-2 to ISO 11111-7.
- d) Reduced running speed combined with an emergency stop which results in a stopping distance according to [Table A.2](#), shall be provided.
- e) Temporary guards (e.g. casing, cover, fence guard) which shield the danger zone during adjustment, maintenance, setting and repair shall be provided.

ISO 11111-1:2016(E)

In cases b), c) and d) above, devices for special operations may only be activated by means of a mode selector (see ISO 12100:2010, 4.11.10) and designed such that they can be used by the operator in the danger zone and positioned such that all danger points can be viewed.

Reference shall be made in the manufacturer's instruction handbook to the correct procedures and precautions for special operations and to the residual risks and the need for specific training of operators to counter these risks. Reference shall also be made to the fact that special operations may only be carried out by authorized and specially trained personnel.

5.6 Access to elevated operating positions and servicing points

Hazards

Mechanical, from machine parts or falling if means of access to the elevated position are not provided, or falling due to the improper use of non-fixed access means.

Safety requirements

The safety requirements and/or measures given in ISO 12100:2010, 6.3.5.6 and ISO 14122-1 to ISO 14122-4 shall apply.

Where access to an elevated position is required occasionally, i.e. less than once per week, information shall be given in the instruction handbook concerning the need for movable platforms or ladders to be provided by the user. Where access is required more frequently than once per week, stationary platforms and/or walkways shall be provided (see [6.13](#)).

Where a ladder is used, means shall be provided to secure the ladder to the machine. The use of ladders shall not be recommended if this increases the risk from the operation which has to be carried out.

5.7 Measures for the escape and rescue of trapped persons

Hazards

Possibility of more severe injury due to delay in rescue or of causing additional injury to the trapped person during the rescue or injury to rescuer when securing release.

Safety requirements

The safety requirements given in ISO 12100:2010, 6.3.5.3 shall apply.

Information shall be included in the instruction handbook on the precise method of rescue to be followed (e.g. the use of specially provided equipment such as easily removable bearings, means to reverse the normal working direction, means to move components apart, pressure-release devices or hand-operated valves for hydraulic or pneumatic systems).

5.8 Fitting of parts

Hazards

Mechanical, from incorrect fitting of parts causing ejection of parts, damage to, or incorrect operation of, the machine, leading to injury.

Safety requirements

Measures shall be provided to prevent a part from being fitted incorrectly (e.g. using shape or configuration to physically prevent incorrect installation). When this is technically not possible the parts shall be clearly marked.

6 Significant hazards and corresponding safety requirements and/or measures for certain machine elements and their combinations

6.1 General

Machinery incorporating any of the following elements shall conform both to the requirements for that particular element as set out in this clause and to the provisions given in ISO 11111-2 to ISO 11111-7 relevant to the machine, and shall be complementary to those given in [Clause 5](#).

6.2 Drive and transmission enclosures

Drive and transmission enclosures are normally used to house the primary and/or transmission drives of a machine when these are grouped together to serve a multiplicity of identical production points (e.g. spinning machines), or to serve a series of related processing elements (e.g. raising machines). They are normally located at the ends or sides of textile machines.

Hazards

Mechanical, from drives including belts, chains and sprockets, pulleys and gears, in particular, entanglement, drawing-in or trapping.

Risks

Occasional access during special operation leading to high probability of severe injury.

Safety requirements

Drives shall be provided with fixed or movable enclosing guards (see [Table 2](#)), as follows.

- a) Fixed enclosing guards shall be fastened in accordance with [Table 2](#).
- b) Where special operations are necessary (e.g. checking and adjusting process controls), the machine shall be designed such that operations can be carried out without opening the enclosing guards; otherwise c), d) and e) shall be complied with.
- c) Where b) cannot be complied with and enclosing guards have to be opened more than once per working shift, they shall be movable and interlocked according to [Table 2](#). Where enclosing guards have to be opened once or less per working shift then fixed guards are sufficient.
- d) Where a device (e.g. a mode selector) is provided to override the interlock to enable certain special operations to take place with the enclosing guard open, one of the following additional measures shall be taken (see [5.5](#)):
 - 1) a hand-operated handle or crank may be provided to enable machines to be driven by hand for special operations;
 - 2) where a hold-to-run control is provided in accordance with [5.5](#) and [Table 3](#), this shall be located in a position from which all dangerous parts can be viewed but not reached within the stopping time;
 - 3) where a reduced running speed (see [A.1](#)) is provided, its actuator shall be located in a position from which all dangerous parts can be viewed and an emergency stop device according to [Table 6](#), shall be provided near dangerous parts within the drive enclosure;
- e) Reference shall be made in the instruction handbook to the type of special operation for which the override device has been provided. See also the final paragraph of [5.5](#).

6.3 Particularly dangerous machine elements

These are machine parts fitted with cutting blades, metallic wire, flexible card clothing, needles, pins, spikes, pegs (including beaters, rollers, cylinders, lattices or similar particularly dangerous elements)

found on machines such as bale breakers, hopper feeders and other fibre-opening units, cleaning and feeding machines, carding machines, teasers, rag teasers, hard waste breakers, rag beaters, willows, raising machines, shearing and cropping machines and other similar machines.

In addition, feed rollers, whether smooth, fluted or covered with teeth, are included under this category where they are located up-stream of the above-mentioned particularly dangerous elements.

Hazards

Mechanical, from such beaters, rollers, cylinders, lattices, etc., in particular, entanglement, drawing-in or trapping, severe abrasion, especially when such elements have a long stopping time.

Risks

Occasional access during normal and special operation, in particular, to remove laps and blockages, leading to high probability of severe or fatal injury.

Safety requirements

- a) To prevent contact with particularly dangerous machine elements, enclosing guards (e.g. casings, covers) shall be provided (see [Table 2](#)).

Fixed enclosing guards may only be used where access is necessary exclusively for major repair.

Movable enclosing guards shall be interlocked according to [Table 2](#). Where the longest stopping time (usually when empty of process material) exceeds the access time, means shall be provided to ensure that the movable enclosing guards cannot be opened or removed until all moving particularly dangerous elements have been brought to a standstill. For example, an interlocking device with guard locking in conjunction with a motion sensor may be used for this purpose. The guard locking device shall operate even when the control system or power supply fails. A brake is a useful aid for reducing stopping time, but shall not be used to replace the guard locking system.

- b) Feed hoppers as well as inlet, discharge, observation, cleaning and other openings shall be in accordance with one of the following:
- 1) so positioned that access to particularly dangerous moving parts is prevented (i.e. the distance from the edge of the opening to the moving part shall comply with ISO 13857:2008, Table 2);
 - 2) fitted with a lattice of bars or similar items within the openings allowing access by operating tools; the distances between the bars shall be such that hand or finger access to the danger zone is prevented, see ISO 13857:2008, Table 4;
 - 3) fitted with an interlocking guard with guard locking to cover those openings, unless the access time always exceeds the stopping time, in which case an interlocking guard without locking may be used.
- c) Feed rollers upstream of, and close to, particularly dangerous machine elements (e.g. on rag-pulling machines) shall be safeguarded by means of enclosing guards (e.g. fixed tunnel guards). The opening of the tunnel shall be in accordance with ISO 13857:2008, Clause 4. Movable panels or doors in the enclosing guard (e.g. tunnel) shall be interlocked with guard locking according to [Table 2](#), unless they are interlocked and the access time exceeds the stopping time of the feed roller.
- d) For normal starting up of particularly dangerous machine elements during special operations (e.g. maintenance, adjustment, setting, elimination of process faults), see [5.5](#).
- e) Where a mode selector is provided in accordance with [5.5](#) it shall not be possible to alter the mode before the machine has come to a standstill.
- f) The safety-related part of the control system of particularly dangerous machine elements shall present a performance level of at least PL = d in accordance with ISO 13849-1 or a safety integrity level SIL = 2 in accordance with IEC 62061.

The adoption of a lower level than performance level PL = d or safety integrity level SIL = 2 shall be based on a risk assessment in accordance with ISO 13849-1:2006, Annex A or IEC 62061:2005+A1:2012+A2:2015, Annex A. See also [5.4.2.3](#).

6.4 Machine elements which normally do not require safeguarding

6.4.1 Low risk machine elements

On textile machinery, many machine elements are found which are normally designed such that there is a low probability of minor injury (see also [A.4](#)).

EXAMPLE Spindles on spinning and twisting machines; feed rollers on open-end spinning, twisting and texturizing machines; thread guides on winding, doubling, twisting and texturizing machines; false twist devices on texturizing machines; feed arrangements of combing and spinning preparatory machines subsequent to carding; ring frame and speed frame drafting systems, including delivery rollers; feed and furnishing devices on warp knitting machines, flat bed knitting machines and circular knitting machines; needles and sinkers on knitting machines; yarn feeding devices, thread guide control, pattern and counting device mechanisms on circular knitting machines; other similar machine elements.

Hazards

Mechanical, from the machine elements referred to above, in particular, entanglement, drawing-in or trapping, impact, friction or abrasion.

Risks

Frequent access during normal operation, leading to low probability of minor injury provided the actuating force and/or mass and velocity of the moving machine elements can be countered by the physical power of the operator (e.g. where the operator can stop the moving part by hand, or withdraw the hand without effort, or where the crushing force is small).

Safety requirements

Where a risk assessment shows that the machine element presents a low risk and a low probability of minor injury, as in the examples given above, precautions are deemed to be sufficient when the correct methods of work are described in the instruction handbook, in particular, hair protection and not wearing loose clothing.

6.4.2 Machine elements out of reach

On textile machinery, dangerous mechanical or thermal machine elements can be arranged such that they cannot be reached from the ground or stationary working platforms work ways.

Hazards

Hazards from dangerous machine elements which are normally out of reach, but can be reached from a mobile platform or a ladder during the performance of special operations.

Risks

Infrequent access during special operation when the machine is run under normal operating conditions leading to low probability of minor to severe injury.

Safety requirements

Dangerous machine elements which cannot be reached during normal operation, but which can be reached during special operations, e.g. by use of a movable ladder, need not be guarded if the risk assessment shows that for the special operation the risk can be reduced to an acceptable level, for instance:

- the special operation may be performed under a standstill or safe running condition (see [5.5](#));

— the machine elements can be rendered non-dangerous by movement to safe positions.

The instruction handbook shall give full instructions for performing the special operations under the above conditions.

6.5 Rollers

Rotating rollers in pairs or stacks, rollers rotating adjacent to fixed parts or rollers with an on-running support blanket or process material, and rough-surfaced rollers, are found on many machines in the textile industry, particularly in the spinning preparatory, weaving preparatory, bleaching, dyeing, printing and finishing industries.

NOTE 1 The term “roller” includes guide rollers, uncurling rollers, padding mangles, drying cylinders, mangle bowls, calender rollers and similar rollers, whether driven directly or by friction between the roller surface and a moving blanket, back cloth or moving process material, which can present a risk to exposed persons unless the movement of the rollers can easily be stopped by hand.

NOTE 2 For brevity, the term “process material” is used in the rest of this subclause to include support blankets, back cloths and process material.

Hazards

Mechanical, from rollers, in particular, entanglement, drawing-in or trapping, crushing and friction or abrasion.

Risks

Access during normal operation, particularly on start-up, smoothing process material, uncurling edges, and access during special operations, particularly cleaning, removal of laps of yarn ends or cloth and threading-up, leading to high probability of moderate-to-severe or fatal injury.

Safety requirements

- a) Prevention of drawing-in of fingers, hands, arms or feet by use of an appropriate spacing (gap) between the rollers.

The gap between any pair of counter-rotating rollers, or between any pair of rollers rotating in the same direction but with different circumferential speeds or surface covering, shall be either between 120 mm and 150 mm, or greater than 500 mm [except for rough-surfaced rollers, see [6.5 h](#)].

- b) Prevention of drawing-in of head and body.

Where the diameters of the rollers are very large (e.g. for drying cylinders in some layouts), there may be risk of the head and body being drawn in for all gaps smaller than 500 mm. If the risk assessment identifies this risk, then safeguarding by gap shall not be used.

- c) Safeguarding of drawing-in points between rollers (see [Table 2](#)).

Where a) cannot be complied with or where b) applies, guards and safety devices shall be provided in accordance with one of the following.

- 1) Fixed enclosing guards, openings within these guards for the passage of process material shall comply with the dimensions given in ISO 13857. See [Figure 1](#) for the location of the danger zone.

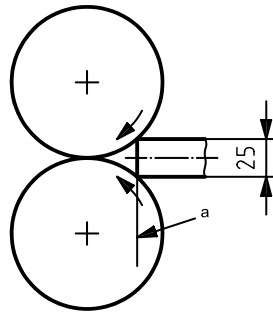

a Beginning of the drawing-in zone.

Figure 1 — Location of danger zone

2) Fixed nip guards close to the drawing-in point (e.g. a nip guard having one of the profiles in [Figure 2](#)).

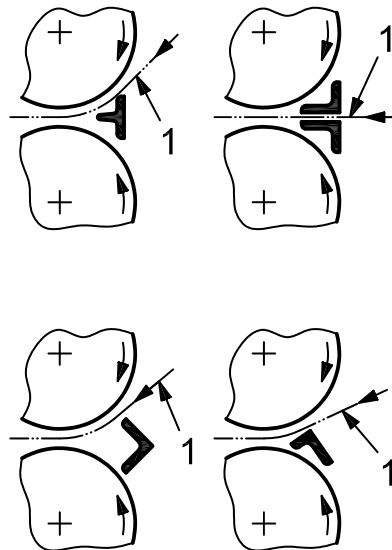

Key

1 process material

Figure 2 — Profiles of nip guards

The profile shall be formed such that at the outer edge it runs parallel to the tangent of the roller surface to avoid a wedge effect (see [Figure 3](#)).

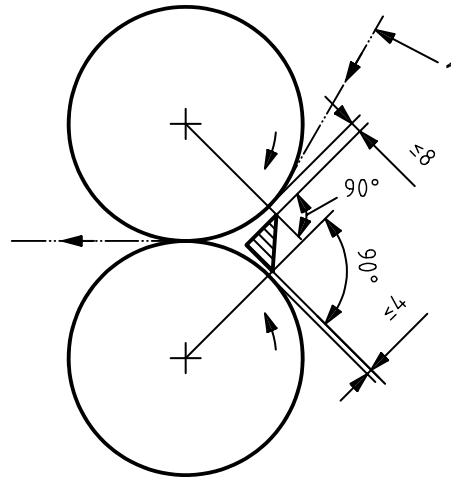
**Key**

- 1 process material

Figure 3 — Nip guard arrangement

Round guards shall not be used because they themselves can create a drawing-in point, together with the adjacent roller surface.

When positioning a guard in close proximity to a rotating surface, a new drawing-in point can be created between the edge of the guard itself and the rotating surface. In order to prevent a danger point being thus created, care shall be taken to ensure that the gap is as small as technically possible with regard to the process. This shall not exceed 4 mm for those gaps not used for the passage of process material (see [Figure 3](#)). Where the guard can damage the roller surface (e.g. due to its unavoidable flexibility on wide machines) or where intermittent thickening of the process material occurs (e.g. by sewn joints), a gap ≤ 8 mm (see [Figure 3](#)) may be used, in deviation from the requirements of ISO 13857.

- 3) Interlocking movable guards and, if stopping time exceeds access time, with guard locking according to [Table 2](#).
- 4) Where guards cannot be used, then safety devices shall be provided, e.g. trip bars according to [Table 3](#), trip panels (see [Figure 4](#)) or active opto-electronic protective devices (AOPD) extending the full width of the drawing-in point. When actuated, such devices shall cause the drive to the rollers to stop and, where the stopping time of the rollers exceeds the access time, cause the rollers to separate immediately to a sufficient distance apart to avoid injury [see [6.5 a](#)) for distances]. Safety devices shall be effective against lateral access or be complemented by guards against lateral access.

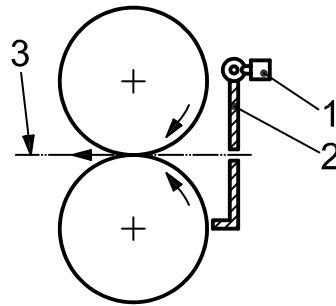

Key

- 1 limit switch
- 2 trip panel
- 3 process material

Figure 4 — Protection by trip panel

Active AOPD according to [Table 3](#), shall be arranged such that the AOPD is activated in the case of access to the drawing-in point and the rollers have come to a standstill or have moved apart to a sufficient distance [see [6.5 a](#)) for distances] before the operator can reach the drawing-in point, e.g. as shown in [Figure 5 a](#)). In order to meet this requirement, with practicable distances between the AOPD and the drawing-in point, it can be necessary to increase access time [e.g. by means of barriers as shown in [Figure 5 b](#))].

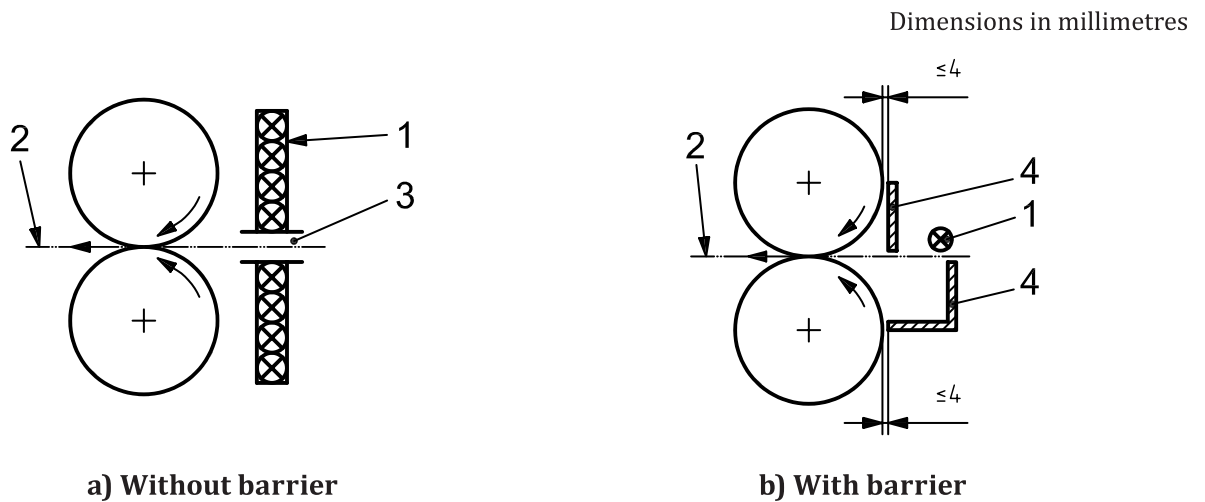

Key

- 1 AOPD
- 2 process material
- 3 blanked area for process material
- 4 barrier

Figure 5 — Protection by active opto-electronic protective device (AOPD)

d) Prevention of drawing-in from reverse side.

Where the rollers during normal operation can run in the reverse direction, precautions are also necessary for the normal outlet side. For special operations, see [5.5](#).

- e) Safeguarding of drawing-in points between rollers and fixed machine parts (see [Table 2](#)).

For danger zones between a roller and a fixed part of a machine or structure next to the machine which is adjacent to the roller, either gaps of dimensions according to [6.5 a\)](#) or guards or safety devices according to [6.5 c\)](#) shall be provided. Alternatively, but only when a wedge effect (as shown at x in [Figure 6](#)) does not exist, a distance between the surface of the roller and the fixed part of less than 4 mm (or 8 mm, see [Figure 3](#)), as shown at y in [Figure 6](#), may be used as the unique measure.

Dimensions in millimetres

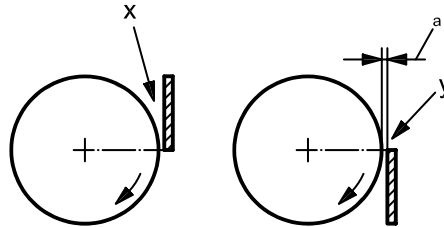

Key

- x wedge effect
- y no wedge effect
- a Distance between roller and fixed machine part ≤ 4 or ≤ 8 .

Figure 6 — Avoidance of wedge effect

- f) Prevention of drawing-in between adjustable rollers.

Where rotating rollers in pairs or stacks normally run in direct contact with each other but can also be run with a gap between them, at either production speed or a slower speed, the guard or safety device chosen shall prevent access to the danger point when the rollers are closed. When the rollers are being run in their separated position, this shall not give rise to a new danger point between any part of the machine and the moving surface of the rollers. Where such a new danger point cannot be avoided, an additional safety device according to [Table 3](#) shall be provided (e.g. sensitive protective equipment).

- g) Safeguarding of drawing-in points between rollers and on-running process material (see [Table 2](#)).

Drawing-in points between rollers and on-running process materials shall not be required to be safeguarded where the conditions set out in Annex D are fulfilled or a risk assessment according to ISO 12100 and ISO/TR 14121-2 shows that there is only a minor risk injury for fingers and hands.

Drawing-in points shall be provided with a guard or safety device conforming to their requirements set out in [5.3.3](#), e.g. by the following:

- 1) a fixed or interlocked movable distance guard in accordance with [Figure 7 a\)](#);
- 2) guards covering both the drawing-in point and the top side, in accordance with [Figure 7 b\)](#), the latter preferably interlocked to the drive, where low tension or low-stiffness process material would otherwise allow encroachment;
- 3) nip guards with profiles in accordance with [Figure 7 c\)](#), where either the tension or stiffness of the process material etc., in itself prevents encroachment, and where such nip guards shall prevent access to the drawing-in point between the process material and the roller;
- 4) safety devices such as trip bars according to [Table 3](#) or AOPDs extending the full width of the drawing-in point, where such safety devices shall, when actuated, stop the drive to the rollers.

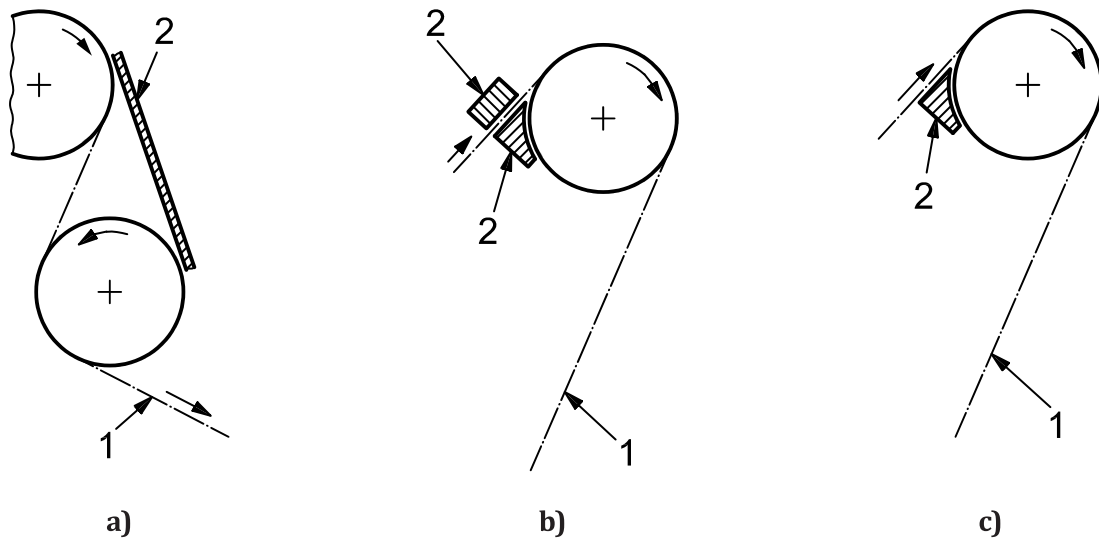

Key

- 1 process material
- 2 guard

Figure 7 — Guards for on-running process material

The AOPD according to [Table 3](#) shall be arranged such that it is interrupted in the case of access to the drawing-in point and the roller has come to a standstill before the operator can reach the drawing-in point. In order to meet this requirement, with practicable distances between the AOPD and the drawing-in point, it may be necessary to increase access time (e.g. by means of barriers as shown in [Figure 8](#)).

Dimensions in millimetres

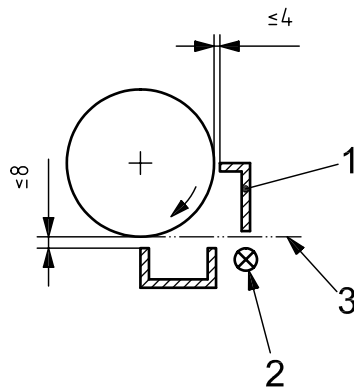

Key

- 1 barrier
- 2 AOPD
- 3 process material

Figure 8 — Protection by active opto-electronic protective device (AOPD)

h) Safeguarding of rough-surfaced rollers.

Rollers having a surface covering of embossed rubber, abrasive cloth or similar material, which operate with a circumferential speed of more than 2 m/min and which are within reach of the operator, shall be provided with fixed guards, interlocked movable enclosing guards or distance guards according to [Table 2](#) over the exposed surface.

Roller surfaces covered with a smooth gumming, a smooth weaving beam, or a card web are not considered to be rough surfaces.

- i) Safeguarding several rollers by one guard (see [Table 2](#)).

A series of rollers may be protected by one guard (e.g. fence guard, distance guard).

- j) Measures relating to special operations.

For starting up rollers during special operations (e.g. maintenance, adjustment, setting, elimination of process faults), see [5.5](#).

- k) The safety-related part of the control system concerning drawing-in points of rollers or rollers and fixed parts shall present a performance level of at least PL = d in accordance with ISO 13849-1 or a safety integrity level SIL = 2 in accordance with IEC 62061.

The adoption of a lower level than performance level PL = d or safety integrity level SIL = 2 shall be based on a risk assessment in accordance with ISO 13849-1:2006, Annex A or IEC 62061:2005+A1:2012+A2:2015, Annex A. See also [5.4.2.3](#).

6.6 Rotating shafts

Rotating shafts used to transmit drive power are found on spinning, winding, doubling, twisting, texturizing, finishing and similar machines.

Hazards

Mechanical, from the shafts, in particular, entanglement of the hair and clothing.

Risks

Frequent access during normal and special operation, leading to high probability of severe injury.

Safety requirements

- a) Rotating shafts shall, where possible, be positioned in accordance with ISO 13857 so that they are not exposed.
- b) Exposed rotating shafts shall be provided with guards (e.g. fixed distance guards or tunnel guards); see [Table 2](#). Loose sleeving is permissible subject to the ends being arranged to prevent the ingress of foreign matter (e.g. yarn between the shaft and the sleeve).
- c) The precautions shall also apply to shafts at the rear of frames which are accessible during special operations.
- d) Smooth shaft ends protruding a distance of no more than a quarter of the diameter and no longer than 5 cm need not be safeguarded.

6.7 Wheels

6.7.1 Running wheels

Machines or sections of certain machines are mounted on wheels to provide mobility, including automated blending bale openers, cross-folders, moving bin emptiers.

Hazards

Mechanical, from the wheels, in particular, crushing and shearing.

Risks

Occasional access during normal and special operation, leading to low probability of moderate-to-severe injury.

Safety requirements

Where a guided machine or machine section is equipped with wheels to travel on rails or another running surface along a fixed path, one of the following measures shall be taken:

- a) a push-away (cow-catcher) device [see [Figure 9 a\)](#)] shall be mounted to protect the trap point between the wheels and the running surface;
- b) sensitive protective equipment [e.g. a trip panel according to [Table 3](#), see [Figure 9 b\)](#)] shall be provided which, when operated, shall cause the machine or the machine section to come to a standstill.

When selecting the type of device to be used, the speed and movement of the machine shall be taken into account.



Key

- 1 wheel
- 2 push-away device
- 3 limit switch
- 4 trip panel

Figure 9 — Safeguarding on wheels

6.7.2 Hand wheels

Hand wheels are variously used on textile machines (e.g. weaving machines and knitting machines).

Hazards

Mechanical, in particular, entanglement of clothing on the rotating surface of the hand wheel or projecting parts and openings.

Risks

During normal operation, when the operator is attending the machine, leading to low probability of moderate injury.

Safety requirements

A hand wheel shall not rotate (i.e. be fixedly coupled to the machine drive), unless the following conditions are fulfilled:

- a) it is not located in the immediate operating or maintenance zone;
- b) it does not protrude out of the machine so that it can be leant on;

- c) it is discoid and is free of protruding parts and openings;
- d) it does not form a drawing in point with another part of the machine.

6.8 Doors and lids

6.8.1 General

Doors and lids are variously used on textile machines (e.g. on autoclaves, kiers, bleaching and dyeing vessels).

6.8.2 Opening and closing

Hazards

Mechanical, from edges of the door or lid, in particular, impact, crushing and shearing.

Risks

Access while the door or lid is opening or closing, leading to low probability of moderate-to-severe injury.

Safety requirements

- a) Means shall be provided to prevent opened doors and lids from falling unintentionally, e.g. including:
 - 1) where there is a risk of the door or lid falling from its open position a catch or a stop beyond the hinge, or other device to hold it securely in the open position;
 - 2) where rapid movement/falling could cause injury an independent hydraulic or pneumatic damping device;
 - 3) chains or ropes when used without damping shall always be used in pairs to avoid the risk of parts falling when a chain or rope fails.
- b) For hand-operated doors and lids, the movement of the door or lid shall take into account ergonomic considerations and mass (inertia). See [5.4.13](#) and [A.4](#).
- c) For power-operated doors and lids, the requirements of [5.4.5](#) apply. Crushing and shearing by the closing door or lid shall be prevented. This may be achieved by one of the following means:
 - 1) the actuating force and speed of movement shall be in accordance with [A.4](#);
 - 2) the edges of the door or lid shall be fitted with a safety device in accordance with [Table 3](#) (e.g. trip bars) which, when operated, will arrest the movement of the door or lid;
 - 3) the door or lid may only be closed by means of a hold-to-run control which is positioned out of reach of the door or lid edges, but at a place where the operator can overlook the door or lid edges.

6.8.3 Locking and unlocking of doors or lids under pressure

Hazards

Mechanical, in particular, impact by the door or lid.

Thermal, in particular, scalding by hot liquor or steam.

Risks

Door or lid bursting open, due either to the application of pressure before the door or lid is fully locked, or to residual pressure inside the vessel or chamber when unlocking; escape of hot liquor or steam, leading to high probability of severe or fatal injury.

General safety requirements

Means shall be provided to deflect any discharge of fluid or steam away from the operator (e.g. deflector panels or rings at the edge of the door or lid).

Specific safety requirements for multi-bolted doors and lids

To facilitate the safe release of any residual pressure, at least one of the bolts on the door or lid which prevent further opening may only be capable of release when a gap of at least 3 mm exists between the door or lid and seal. Such bolts shall be placed on the edge of the door or lid opposite to hinge or hinges.

Specific safety requirements for quick-locking doors and lids

- a) Interlocking according to [Table 3](#), between the door-locking mechanism, the vent valve and all pressurizing systems (e.g. steam, water, compressed air, pumps, heating) shall be provided so that the pressurizing systems are turned off and isolated, and the vent valve is open before beginning to unlock the door or the lid (see example of principle of mechanical interlocking in ISO 14119:2013, Annex H). These measures shall remain effective until after the door or the lid is fully closed and relocked.
- b) Unlocking shall incorporate two individual stages. In the first stage, the door is partially unlocked, but still restrained (it is essential that the restraint be strong enough to withstand any residual forces); the door or the lid shall be fully open within the limits of the restraint (until there is a gap of not less than 8 mm between the door or the lid and the seal) before the final stage of unlocking can begin and the door or the lid can be opened.
- c) In the case of vessels containing liquid:
 - 1) for vertical vessels, the lid shall be interlocked with guard locking according to [Table 3](#), with the valve of an open-ended drain, which may also be the main drain, and shall remain locked until the liquor level is sufficiently below the top of the vessel;
 - 2) for horizontal vessels with full-size doors, an interlocked drain valve shall be used to ensure that no liquid is left in the vessel before beginning to unlock the door;
 - 3) care shall be taken in sizing and positioning of these drains to ensure that they cannot be blocked by the contents of the vessel and that any discharge from the drain is deflected away from the operator.

6.8.4 Entry into machines, vessels or items of plant

Hazards

Mechanical, when an operator enters vessels or plant and can be injured or shut inside with the machine functioning.

Risks

During normal and special operation, low probability of severe or fatal injury.

Safety requirements

- a) Doors providing access to the hazardous zone shall be interlocked with the machine. When the run down time is sufficient to allow access to dangerous parts or when specified in ISO 11111-2, ISO 11111-3, ISO 11111-4, ISO 11111-5, ISO 11111-6 and ISO 11111-7, interlocking with guard locking shall be provided (see [Table 3](#)).
- b) The machine shall not be restarted by closing an access door, but only by actuating the start control at the control panel. Every access point shall be fitted with a manually operated reset control system, e.g. reset control or key system, unless all danger points can be viewed from the control panel. The reset control system shall not be capable of being actuated from a danger zone. The

reset control shall be inoperative while a door is open. The start control shall be effective only when all doors are closed and all reset control systems have been actuated.

- c) The door shall be designed in a way that it can be opened from inside unless an additional and accessible control device provided in the danger zone prevents the reset of the machine.

6.9 Observation windows

Observation windows are to be found in the guards or coverings of many textile machines.

Hazards

Mechanical, when the window is open or the window material is broken or damaged, in particular, hazards from various dangerous parts behind the window or cutting from the broken window.

Risks

High probability of moderate-to-severe injury if access to danger zones is possible and low probability of minor injury from broken window material.

Safety requirements

Observation windows behind which particularly dangerous machine elements (see [6.3](#)) or fan blades can be reached shall be either fitted in a nondetachable manner (e.g. by inserting them into rubber seals, by welding or by fastening them from the inside or with safety bolts) or interlocked and, if stopping time exceeds access time, with guard locking.

Windows shall be of material suitable to withstand mechanical and/or thermal damage and, where necessary, chemical attack (e.g. polycarbonate sheet or toughened glass).

6.10 Conveyors

Conveyors are incorporated in textile machinery in a variety of forms and dimensions.

Hazards

Mechanical, from the conveyor itself, between the conveyor belt and pulley, between parts of the conveyor and adjacent machine parts, between two conveyors or between a conveyor and a roller, from removal of process material.

Risks

Access during normal and special operation, in particular, during incidental cleaning or removal of blockages, leading to low probability of moderate-to-severe injury.

Safety requirements

- a) For lattice conveyors, the bars of the lattice shall be spaced very close together so that fingers cannot be trapped (in general, a maximum opening of 6 mm is acceptable).
- b) For intake points, between the conveyor belt and,
 - 1) a driven pulley,
 - 2) a non-driven pulley where the conveyor belt is tensioned, or
 - 3) a non-driven pulley where the conveyor belt is guided such that it is not free to lift from the pulley, fixed guards or movable interlocked guards (e.g. lateral distance guards or fixed nip guards) shall be provided in accordance with [Table 2](#). As far as is possible, guards shall be

designed so that they can remain in position when adjustments, for example belt tensioning, are carried out.

- c) For shear points between moving parts of the conveyor and fixed parts of the machine, enclosing or distance guards shall be provided (see [Table 2](#)).
- d) For the drawing-in points between two conveyors or between a conveyor and a roller, see [6.5 c](#)).
- e) Where conveyors are used in processes where it is likely that materials (e.g. fibres) will accumulate on the surfaces of the conveyor or pulleys, the conveyor shall be designed and constructed to allow, as far as possible, cleaning to be done without removing the guards. Fixed cleaning devices shall be fitted, where possible. If guards have to be removed regularly for cleaning purposes, they shall be interlocked (see [Table 2](#)).

6.11 Fans

Fans are found on many textile machines including blow room machinery, pneumatic fibre transport systems, spinning preparatory and spinning machines, stenters and other drying machines.

Hazards

Mechanical, from blades; in particular, entanglement of hair and clothing, and impact or cutting.

Noise from the fan and the fan casing and, where used for fibre transport, impact from fibres and impurities on the internal surfaces of the casing.

Risks

Occasional access during special operation, including removal of blockages of process material and cleaning, leading to high probability of moderate-to-severe injury.

A probability, depending on exposure, of hazards due to noise.

Safety requirements

- a) The fans shall either be positioned in accordance with ISO 13857 so that they are not within reach of the operator or be guarded (see [Table 2](#)).
- b) Where occasional access is necessary for removal of blockages of process material (e.g. in pneumatic fibre transport systems), openings shall be positioned at a distance from the blades sufficient to prevent access by the fingers, but allowing access by means of a tool to remove a blockage. Alternatively, the openings may be close to the fans provided that each is covered with a movable interlocked guard with guard locking (see [Table 2](#)). A warning shall be given in the instruction handbook concerning the fact that connecting ducts, installed by the user or other person, for a fibre transport system shall not have any openings within reach of the fan.
- c) Noise created by the fan shall be reduced by design to minimize hazards due to noise. Examples of reduction measures include anti-vibration mountings, acoustic enclosures and locating fans remotely from working areas.

6.12 Cutting devices

Circular, straight and spiral cutting blades are variously used on machines and processes in the textile industry (e.g. tow-cutting, nonwoven production, shearing and cropping of carpet, finishing, stenters, automatic batchers and other machines).

Hazards

Mechanical, from the cutting device, in particular, cutting or severing, or from the blade supports, in particular, crushing and shearing.

ISO 11111-1:2016(E)

Thermal, from heated knives or where heat is generated during the course of operation of the cutting device.

Risks

Occasional access during normal and special operation, leading to high probability of minor cuts and low probability of severed fingers, hands or arms. High probability of moderate-to-severe injury when handling knife blades.

Safety requirements

a) Fixed-position circular blades

Enclosing guards shall be provided, which enclose the blades as far as technically possible in relation to the process being carried out (see [Table 2](#)). These shall be adjustable or self-adjusting.

b) Traversing circular blades

Access shall be prevented to the blades and associated parts including any clamp which, together with fixed machine parts, form crush and shear points when traversing.

This requirement may be achieved by a fixed guard extending the length of the traverse, or sensitive protective equipment (e.g. AOPD), preventing the start of the traversing motion or causing it to be interrupted immediately if an operator reaches into the danger zone (see [Tables 2](#) and [3](#)).

c) Guillotine-type blades

Means shall be provided to prevent access to the danger zone while the blade is in motion; for example, this may be achieved if, on entry and exit sides of the blade, tunnel guards are provided whose dimensions correspond to ISO 13857. Movable guards (e.g. hinged covers) within the tunnel shall be interlocked with the motion of the blade (see [Table 2](#)).

If such a cutting device is incorporated in a textile installation having fence guards (see [Table 2](#)), access doors interlocked with the movement of the blade shall be provided in front of, and behind, the cutting device (see [A.3](#)). If fence guards are not provided, the work area shall be secured by means of safety devices (e.g. an AOPD system or pressure-sensitive mats or floors), which prevent movement of the blade as long as a person can reach it (see [Table 3](#)). The stopping time shall be shorter than the access time.

Interlocking devices of guards and fixed parts of guillotine-type blades shall present a performance level of at least PL = d in accordance with ISO 13849-1 or a safety integrity level SIL = 2 in accordance with IEC 62061.

The adoption of a lower level than performance level PL = d or a safety integrity level SIL = 2 shall be based on a risk assessment in accordance with ISO 13849-1:2006, Annex A or IEC 62061:2005+A1:2012+A2:2015, Annex A. See also [5.4.2.3](#).

For the protection of the operator during the changing of blades, mechanical restraints shall be provided to prevent the blade carrier from falling.

d) Spiral blades: see [6.3](#).

6.13 Working platforms and walkways on machines, work areas adjacent to tanks and pits

Working platforms and walkways are provided on various textile machines, including filament processing, spinning preparatory processing, weaving (Jacquard), printing, continuous dyeing and finishing lines. Pits are to be found in carding in particular. Tanks are to be found in the bleaching, dyeing and finishing industries.

Hazards

Falls from platforms and walkways, slipping or tripping, falling into an adjoining tank or pit, injury caused by items dropping from platforms and walkways.

Risks

Access to working platforms and walkways located in a raised position or to working areas adjacent to tanks and pits, leading to low probability of moderate-to-severe injury during normal and special operation.

Safety requirements

- a) For working platforms, walkways and their access the requirements of ISO 14122-1 to ISO 14122-4 shall apply.

Where a working platform or walkway is provided from which access to a danger zone is possible, guards and safety devices shall be provided to prevent such access (see [Tables 2](#) and [3](#)).

- b) To avoid falling into items of plant such as tanks or pits, these shall be designed so that the upper edge will be at least 1 100 mm above the surface of the workplace. Otherwise, there shall be a fence guard or barrier of 1 100 mm height, infilled with sheeting or vertical bars spaced not more than 180 mm apart, around the edge of the tank or pit unless other parts of the machine or plant provide a barrier without creating additional hazards (e.g. heat, rotation).

6.14 Radiators or burners for the direct heat treatment of yarn and fabric

Open radiators or burners are found on yarn and fabric treatment machinery (e.g. singeing and baking).

Hazards

Thermal, in particular, burns through contact with flame or radiating heat sources or burning process material.

Risks

Access during special operation leading to high probability of moderate-to-severe injury.

Safety requirements

- a) Unintentional access to the radiator(s) or burner(s) shall be prevented.
- b) On gas-fired plants, fast shut-off valves shall be provided in the gas supply pipe.
- c) For plants other than gas-fired when the speed at which the process material is being transported decreases or the machines stops, then one of the following shall be provided:
- 1) means of separating automatically the heat source and the process material;
 - 2) shields automatically introduced to form a thermal barrier between the heat source and the process material.
- d) The instruction handbook shall advise that cleaning is necessary at appropriate intervals.

6.15 Devices for steam heating of liquors

Steam injection tubes are found, for example, in wool scouring, backwashing, bleaching, dyeing and finishing machinery.

General safety requirements

The safety requirements of [5.4.6.2](#) for hot liquor or steam shall apply.

Specific hazards

Noise caused by direct injection of live steam into liquor. Scalding caused by ejection of live steam or hot liquor, particularly when the liquor level is low.

Specific risks

A probability, depending upon exposure, of hazards due to noise, a low probability of severe injury by scalding during heating of the liquor.

Specific safety requirements

Live steam injection shall include low-noise steam injector mechanisms (see ISO 23771) to reduce hazards due to noise.

Where live steam is used, injection tubes shall be designed to avoid ejection of steam or hot liquor from the vessel (see [Figure 10](#)).

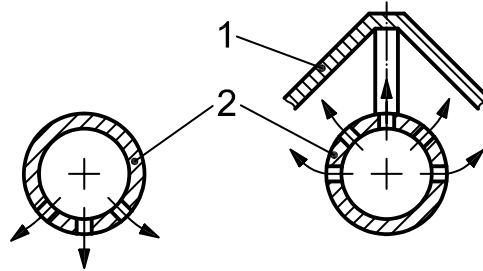

Key

- 1 shield
- 2 steam tube

Figure 10 — Examples of low-risk steam injection tubes

6.16 Liquor preparatory machinery incorporating stirrers

Liquor preparatory machinery is variously used in the textile industry (e.g. in sizing, dyeing, printing). Stirrers are variously incorporated in machinery for the preparation of size, dyeing and printing liquors.

General safety requirements

The safety requirements of [5.4.6.2](#) for hot liquor or steam shall apply.

Specific hazards

Mechanical, from shaft couplings, in particular, entanglement or from the blades, especially impact and crushing.

Thermal, resulting from ejection of liquor and boiling over of liquor.

Specific risks

When adjacent to the vessel, particularly when opening the lid for monitoring or cleaning, leading to low probability of severe injury.

Specific safety requirements

- a) Where access to the stirrer drive-shaft coupling is possible, protruding parts of the coupling shall be recessed or guarded (e.g. by a stainless steel mesh).
- b) Where the stirrer and the mixing vessel can be moved apart, means shall be provided to permit stirrer operation only when in position in the mixing vessel and to prevent the stirrer falling from the raised position.

- c) Where there is a risk of hot or otherwise hazardous liquor being ejected because of the high speed of the stirrer, interlocked lids which can be opened only at an appropriate low stirrer speed or at a standstill shall be provided.
- d) Where there is a risk of liquor boiling over, the heat supply shall be interrupted when opening the lid.

6.17 Dancing rollers

This equipment is used to store varying amounts of warp yarn, fabric or carpet during or between processes, or to control speeds (e.g. storage accumulators, compensators, festoons).

Hazards

Mechanical, from rollers moving past each other or moving past fixed parts of the support framework or falling, in particular, crushing, shearing and impact.

Risks

Low probability of severe-to-fatal injury during normal operation.

Safety requirements

- a) Fixed guards shall be provided which shield the total travel of the rollers (e.g. enclosing guards, distance guards or fence guards) in accordance with [Table 2](#).
- b) Where provided, access doors shall be interlocked (see [Table 2](#)).
- c) Restraint devices shall be provided to prevent the movable parts from falling.

NOTE Dancing rollers which do not cause crushing or shearing hazards do not need the special requirements mentioned above.

6.18 Batching devices

6.18.1 General Information

Batching devices are used to wind fabric or carpets into a batch, in particular in non-woven fabric production, in weaving mills, hosiery mills, bleach works, dye shops, printing plants and finishing equipment.

General safety requirements

Batching devices shall comply with the general safety requirements given in [Table 9](#).

Table 9 — General safety requirements relating to batching devices

Application	Reference
All machines:	
Electrical equipment in general	5.4.2.1 and 5.4.2.2
Electrical control systems	5.4.2.3
Starting and stopping	5.4.2.4
Reduction of risks by design	5.3.2
Reduction of risks by safeguarding	5.3.3
— with guards	Table 2
— with safety devices	Table 3
Fluid power systems and components	5.4.5
Devices for special operation	5.5
Escape and rescue of trapped persons	5.7
Fitting of parts	5.8
Particular machine elements:	
Drive and transmission enclosures	6.2
Rollers	6.5
Rotating shafts	6.6

For centre batchers with a surface speed exceeding 2 m/min, the danger points in the winding area shall be safeguarded by preventing access with a fence guard in accordance with [A.3](#), or by the means described in [6.18.2](#), [6.18.3](#) and [6.18.4](#), as relevant.

If a fence guard is used, the enclosure shall have an interlocked gate and if the stopping time exceeds the access time the enclosure shall remain interlocked and have an interlocked gate. To facilitate the start-up of a batcher, the interlocking device may be fitted with an override switch provided that overriding also automatically restricts movement of the batcher to crawl speed by means of a hold-to-run control device or limited movement control devices. These control units may be intended for actuation by hand, by leg or by foot.

The parts of the control system related to the interlocking and other safety provisions of all batcher types described in this subclause shall present a performance level of at least PL = d as defined in ISO 13849-1, or a safety integrity level SIL = 2 as defined in IEC 62061 (see [5.4.2.3](#)).

The adoption of a performance level lower than PL = d or a safety integrity level lower than SIL = 2 shall be based on a risk assessment in accordance with ISO 13849-1:2006, Annex A or IEC 62061:2005+A1:2012+A2:2015, Annex A.

6.18.2 Surface-driven batcher

Surface-driven batchers are batching devices where the fabric batch is supported in the centre with a driving roller resting on the fabric batch.

General safety requirements

The safety requirements and/or measures shall be in accordance with [6.18.1](#).

Special hazards

Mechanical, from machine parts, especially rollers, from the process material during the winding operation, in particular, drawing-in or trapping, and from the lowering of the drive arm, in particular, crushing.

Special risks

Access during normal operation, particularly start-up of a new batch, and also when the fabric is smoothed and edges are uncurled, leading to low probability of severe or fatal injury and in other cases to high probability of minor or moderate injury.

Special safety requirements

Surface-driven batchers shall be provided with a fixed or movable guard or sensitive protective equipment (SPE) covering the entire width at the drawing-in point between the web and the fabric batch in accordance with [5.3.3](#).

The guard or the SPE shall be designed to compensate for the progressively increasing diameter of the batch. Actuating the guard or the SPE shall cause the drive to stop and to lift the drive roller immediately to a distance of more than 120 mm from the surface of the cloth batch.

If, for technical reasons, the SPE cannot be positioned in accordance with ISO 13855, the SPE shall be arranged in such a way that it is activated automatically by the operator approaching the drawing-in point, and that it can be activated intentionally by the operator. In this case, the appropriate position of the SPE shall be defined on the basis of a specific risk assessment. If, with the best available solution, residual risks remain, these risks shall be indicated by warnings at the hazard zone and the corresponding measures shall be described in the instruction handbook to enable safe working, in particular during batch changing.

NOTE In many cases, the positioning of the SPE in full compliance with ISO 13855 is considered not possible for technical reasons, but when drafting this part of ISO 11111 it was not possible to define precise special criteria for the positioning of the SPE to the variety of batchers.

An example for the arrangement of an SPE in combination with a feed roller is shown in [Figure 11 a\)](#). The feed roller (4) impedes access to the drawing-in point. The distance between the SPE (5) and the drawing-in point at the driving roller (3) is at least 120 mm, while the SPE is kept by the feed roller at the least possible distance to the batch (6).

An example of a solution for adapting the position of the SPE to the increasing winding diameter via two sensing edges arranged in tandem is shown in [Figure 11 b\)](#). The distance between the sensing edges and fabric batches should be kept as small as possible. Depending on the winding diameter, either the front or the back sensing edge is closer to the fabric batch.

It may only be possible to lower the arm of the driving roller by a hold-to-run control device or, alternatively, guards or SPE should be provided in order to prevent crushing between the driving arm and the fabric batch during this operation. (See [5.3.3](#) and [Tables 2](#) and [3](#)). The appropriate position of the SPE shall be defined on the basis of a specific risk assessment.

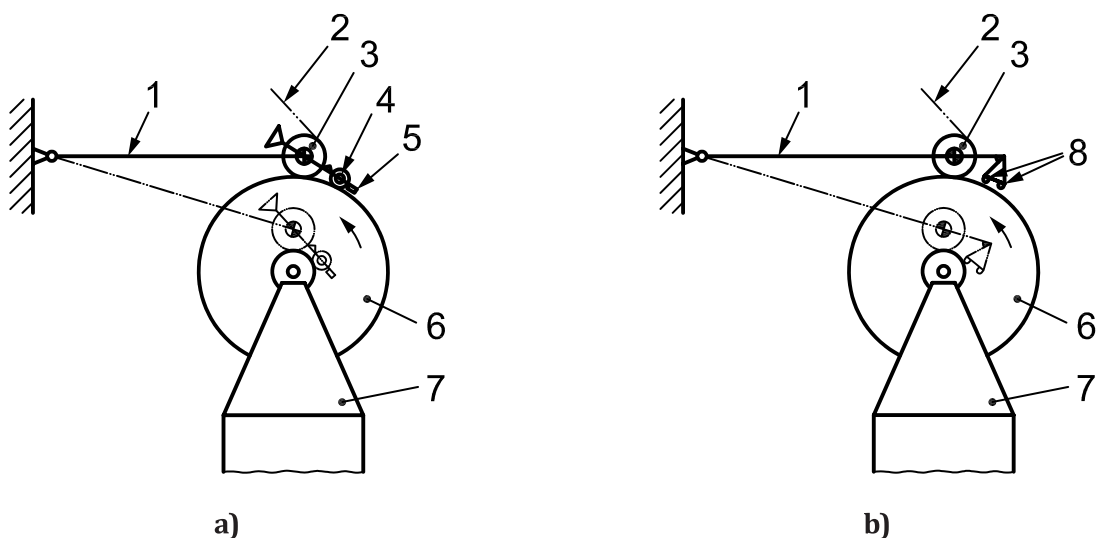

Key

1	arm	5	SPE (sensitive line)
2	fabric	6	fabric batch
3	driving roller	7	batch rack
4	feed roller	8	two sensing edges

Figure 11 — Protection equipment for surface-driven batcher

Surface-driven batchers with a fabric speed exceeding 150 m/min shall be provided with a fence guard in accordance with [A.3](#) or with a limiting access by AOPD. Where service is required, the approach speed for AOPD may be disregarded in derogation from ISO 13855. For a vertical detection zone through multiple light barriers, the required minimum distance between detection zone and hazard zone results from the minimum distance for reaching over (ISO 13855:2010, Table 1) and reaching through (detection capability). If this is necessary, the limiting access may be deactivated by a key switch, allowing only crawling speed. For this purpose, an additional SPE, which always remains active, shall be mounted at the drawing-in point.

6.18.3 Centre batcher

Centre batchers are batching devices where the fabric batch is supported and driven in the centre.

General safety requirements

The safety requirements and/or measures shall be in accordance with [6.18.1](#).

Special hazards

Mechanical, from machine parts and process material during the winding operation, in particular, drawing-in or trapping.

Special risks

Access during normal operation, particularly start-up of a new batch, and also when the fabric is smoothed and edges are uncurled, leading to low probability of severe or fatal injury and in other cases to high probability of minor or moderate injury.

Special safety requirements

Centre batchers shall be provided with a fixed or movable guard or an SPE covering the entire width at the drawing-in point between the web and the fabric batch in accordance with [5.3.3](#).

The guard or SPE shall be designed to compensate for the progressively increasing diameter of the batch.

If it is impossible to fit a guard or SPE at the drawing-in point, the centre batcher should be fitted with an SPE which is attached to the operating side.

If, for technical reasons, the SPE cannot be positioned in accordance with ISO 13855, the SPE shall be arranged in such a way that it is activated automatically by the operator approaching the drawing-in point and that it can be activated intentionally by the operator. In this case, the appropriate position, of the SPE shall be defined on the basis of a specific risk assessment. If, with the best available solution, residual risks remain, these risks shall be indicated by warnings at the hazard zone and the corresponding measures shall be described in the instruction handbook to enable safe working, in particular during batch changing.

NOTE In many cases, positioning of the SPE in full compliance with ISO 13855 is considered not possible for technical reasons, but when drafting this part of ISO 11111 it was not possible to define precise special criteria for the positioning of the SPE to the variety of batchers.

[Figure 12](#) gives an example of a suitable construction for the SPE for a centre batcher without pressure roller showing a floor-mounted sensitive bar.

It is also possible to mount the SPE on the batcher rack.

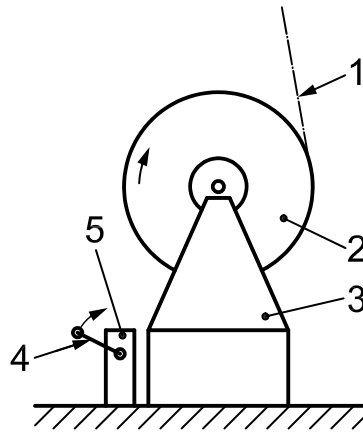

Key

- 1 fabric
- 2 fabric batch
- 3 batch rack
- 4 SPE (sensitive bar)
- 5 cross members

Figure 12 — Safety equipment for centre batcher without pressure roller with running speeds below 150 m/min

Centre batcher rollers with a surface speed exceeding 150 m/min shall be provided with a fence guard in accordance with [A.3](#) or with a limiting access by AOPD. Where service is required, the approach speed for AOPD may be disregarded in derogation from ISO 13855. For a vertical detection zone through multiple light barriers, the required minimum distance between detection zone and hazard zone results from the minimum distance for reaching over (ISO 13855:2010, Table 1) and reaching through (detection capability). If this is necessary, the limiting access may be deactivated by a key switch, allowing only crawling speed. For this purpose, an additional SPE, which always remains active, shall be mounted at the drawing-in point.

[Figure 13](#) gives an example of a centre batcher without pressure roller for fabric speeds above 150 m/min, safeguarded by AOPDs.

Dimensions in millimetres

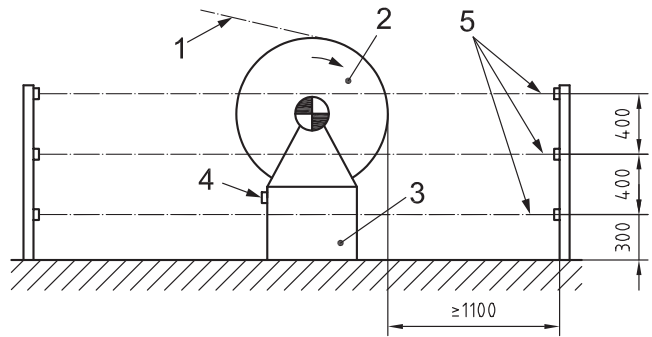

Key

- 1 fabric
- 2 batch
- 3 batch rack
- 4 SPE (sensitive bar)
- 5 AOPD

Figure 13 — Safety equipment for centre batcher without pressure roller with running speeds above 150 m/min

Centre batchers with an undriven pressure roller shall be provided with safeguarding in accordance with [6.18.2](#).

An example of a solution with an undriven pressure roller of a centre batcher up to 150 m/min, compensating the position of the SPE to the increasing diameter of the batch is shown in [Figure 14](#). The distance between the SPE and fabric batch is kept as small as possible by a mechanical gearbox that changes the position of the SPE to suit the position of the arm.

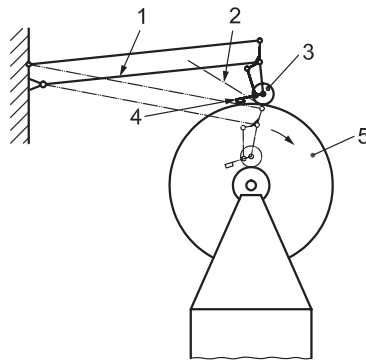

Key

- 1 arm
- 2 fabric
- 3 undriven pressure roller
- 4 SPE
- 5 fabric batch

Figure 14 — Protection equipment for centre batcher with undriven pressure roller

If batching devices are equipped with both surface and centre drive, the appropriate guarding for both batcher types shall be installed in accordance with [6.18.2](#) and [6.18.3](#).

6.18.4 Ascending batch winder

Ascending batch winders are batching devices with one or two rotary (same direction) horizontal driving roller(s) on which fabric batches are generated.

General safety requirements

The safety requirements and/or measures shall be in accordance with [6.18.1](#).

Special hazards

Mechanical, from machine parts, especially rollers, from the process material during the winding operation, in particular, drawing-in or trapping.

Special risks

Access during normal operation, particularly start-up of a new batch, and also when the fabric is smoothed and edges are uncurled, leading to low probability of severe or fatal injury and in other cases to high probability of minor or moderate injury.

Special safety requirements

Ascending batch winders that have an accessible drawing-in point shall be provided with an SPE in accordance with [Table 3](#), fitted at the operating side across the entire width.

If, for technical reasons, the SPE cannot be positioned in accordance with ISO 13855, the SPE shall be arranged in such a way that it is activated automatically by the operator approaching the drawing-in point and that it can be activated intentionally by the operator. In that case, the appropriate position of the SPE shall be defined on the basis of a specific risk assessment. If, with the best available solution, residual risks remain, these risks shall be indicated by warnings at the hazard zone and the corresponding measures shall be described in the instruction handbook to enable safe working, in particular during batch changing.

NOTE In many cases, positioning of the SPE in full compliance with ISO 13855 is considered not possible for technical reasons, but when drafting this part of ISO 11111 it was not possible to define precise special criteria for the positioning of the SPE to the variety of batchers.

If the SPE does not cover the access to the drawing-in point from the side of the batcher, additional lateral guards shall be provided.

An example of a suitable construction of the SPE for an ascending batcher having running speeds of up to 150 m/min is given in [Figure 15 a\)](#) and [Figure 15 b\)](#).

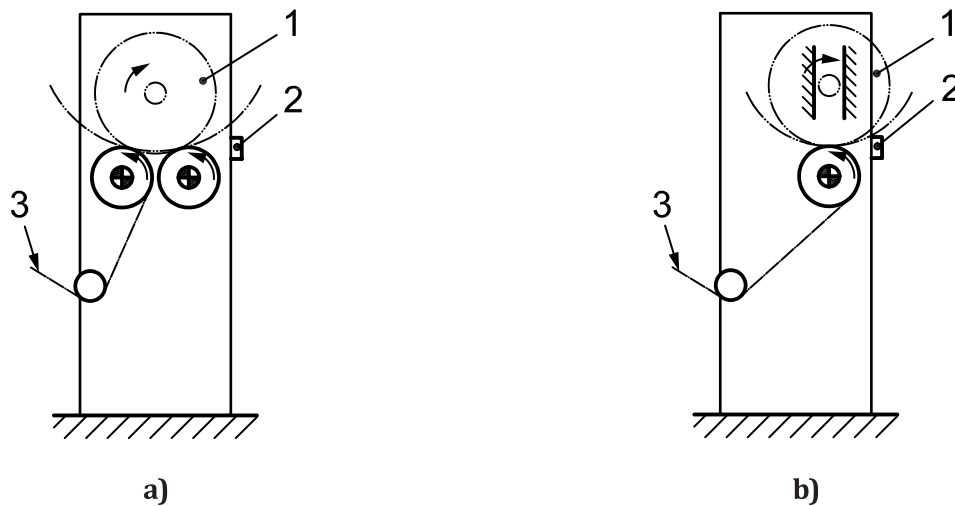

Key

- 1 fabric batch
- 2 SPE
- 3 fabric

Figure 15 — Precautions on ascending batch winders with running speeds up to 150 m/min

Ascending batch winders with a surface speed exceeding 150 m/min shall be provided with a fence guard in accordance with A.3 or with a limiting access by AOPD. Where service is required, the approach speed for AOPD may be disregarded in derogation from ISO 13855. For a vertical detection zone through multiple light barriers, the required minimum distance between detection zone and hazard zone results from the minimum distance for reaching over (ISO 13855:2010, Table 1) and reaching through (detection capability). If this is necessary, the limiting access may be deactivated by a key switch, allowing only crawling speed. For this purpose, an additional SPE, which always remains active, shall be mounted at the drawing-in point.

6.18.5 Equipment for automatic process material change on batching devices

Equipment for automatic process material change can be applied for all batcher types mentioned in this subclause.

Special hazards

Mechanical hazards, in particular crushing and shearing, impact between moving and fixed machine parts and the fabric batch.

Special risks

Intentional or unintentional access by endangered persons during automatic process material changing operations as well as access during special operation, leading to high probability of minor or moderate injury and low probability of severe or fatal injury.

Special safety requirements

On batchers with automatic process material changing facilities, precautions shall be taken to prevent access to the transfer units, including the cutting and threading-up devices and the area traversed by the arm of the drive roller, during the transfer operation.

The safety requirement can be satisfied by installing a visual or acoustic warning signal to warn that batch changeover is about to occur and surrounding the entire batcher unit by a fence guard in

accordance with [A.3](#) (see [Figure 16](#)). Doors provided in the fence guard shall be interlocked with the changing unit control so that the changing operation cannot be started as long as the door is open or will be interrupted as soon as the door is opened. The automatic changing operation shall be restarted manually after actuating the reset control in accordance with [A.3](#).

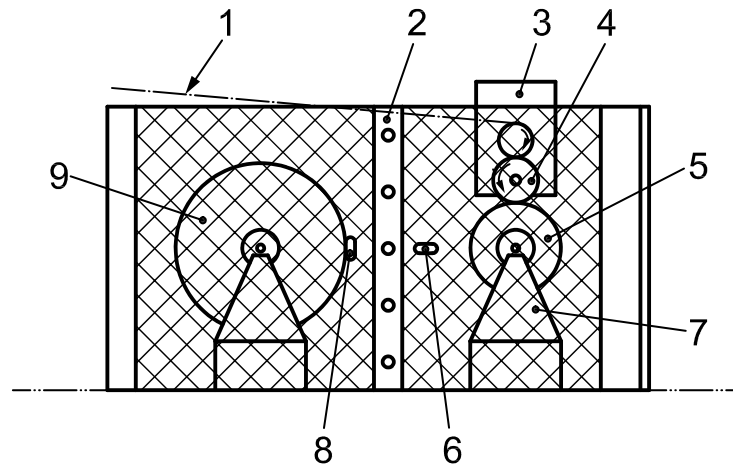

Key

- 1 fabric
- 2 arrangement of AOPD
- 3 transfer unit for cloth
- 4 mobile drive roller
- 5 batch in operation
- 6 door, interlocked at present
- 7 batcher frame
- 8 door, unlocked
- 9 batch (finished)

Figure 16 — Safeguarding of automatic batcher units

Additionally, the fence guard may safeguard the drawing-in and winding-on zones of the batcher, provided that the drive to the batcher is interlocked with the doors.

Otherwise, all hazard zones of the batcher shall be safeguarded in accordance with [6.18.2](#), [6.18.3](#) and [6.18.4](#).

On a batching device with two fabric batcher units, when the fence guard protects the drawing-in and winding-on points, the interlock on the door of the currently non-operational side may be muted when changing the units. During the change, access to the operating batcher shall be prevented by one of the following measures.

- a) By using either a fence guard or an arrangement of AOPDs installed between the two batcher units. The arrangement shall be activated immediately when one of the doors is opened.
- b) By protecting the unit in part by a fence guard and in part by an AOPD in accordance with ISO 13855.
- c) By equipping the work area with an SPE, such as pressure-sensitive mats or floors or AOPDs responsive to diffuse reflection (AOPDDR) in accordance with [5.3.3](#) and [Table 3](#), which provide protection equivalent to a fence guard. Where the drawing-in and winding-on points of the individual batcher are effectively protected, it is sufficient to activate the pressure-sensitive mats or floors or AOPDDR immediately before changing the process material.
- d) By protecting each danger zone by guards and safety devices (see [5.3.3](#) and [Tables 2](#) and [3](#)).

For batchers with semi-automatic process material change, where the change of process material is triggered manually by the operator after a signal has indicated the end of the winding process, safeguarding measures for the change facility, unlike fully automatic change facility, are not required, provided that the operator initiates the change operation by means of a hold-to-run control at a position from which the changing operation can be watched in full, but not accessed.

In this case, it is necessary for the batcher's design to meet the requirements given in [6.18.2](#), [6.18.3](#) and [6.18.4](#).

6.19 Mangles

Mangles are variously used on dyeing and finishing machines to squeeze the process fabric.

General safety requirements

The safety requirements of [5.7](#) for escape and rescue of trapped persons shall apply.

Specific hazards

Mechanical, from the mangle bowls (rollers) when they are running, close or apart and when they are being moved together, in particular, drawing-in or trapping, crushing.

Specific risks

Occasional access during normal operation and special operation, particularly threading up and cleaning, leading to high probability of severe injury.

Specific safety requirements

- a) One of the following guards shall be provided to prevent access to the running bowls:
 - 1) fixed nip guards in accordance with [6.5 c\)](#);
 - 2) interlocking guards with guard locking unless the access time exceeds the stopping time, in which case interlocking guards without guard locking may be used (see [5.3.3](#) and [Table 2](#)).
- b) One of the following means shall be provided to hold the mangle bowls apart (e.g. during threading up):
 - 1) an electropneumatic restraint device;
 - 2) a hydraulic restraint device;
 - 3) a mechanical restraint device.
- c) When the bowls are moving together, one of the following precautions shall be taken:
 - 1) access to the bowls prevented by a guard;
 - 2) a hold-to-run control controlling movement of the bowls, provided they can be viewed from the operating position;
 - 3) a visual or acoustic warning signal given before the bowls move together and hand- or foot-operated emergency sensitive protective equipment which can be actuated from both sides (e.g. a trip-wire), provided for every mangle.
- d) Interlocking devices of guards at drawing-in points of rollers shall present a performance level of at least PL = d in accordance with ISO 13849-1 or a safety integrity level SIL = 2 in accordance with IEC 62061.

The adoption of a lower level than performance level PL = d or a safety integrity level SIL = 2 shall be based on a risk assessment in accordance with ISO 13849-1:2006, Annex A or IEC 62061:2005+A1:2012+A2:2015, Annex A. See also [5.4.2.3](#).

6.20 Pilers and plaiters

Pilers and plaiters are variously used on dyeing and finishing machines to deposit process fabric into the recipient container or pit.

Hazards

Mechanical, from the traversing mechanism, in particular, crushing, shearing and impact.

Risks

Occasional access during normal and special operation, leading to low probability of minor to fatal injury.

Safety requirements

Piler or plaiter mechanisms shall be designed so that crush and shear points are eliminated. Where this is not practicable, guards or safety devices shall be provided (see [Tables 2](#) and [3](#)). The edges of pilers and plaiters traversing at a height of less than 2,0 m shall be padded.

6.21 Automatic machines and equipment

6.21.1 General

Automatic textile machines and equipment are those for which control systems are employed to govern their operation, without further intervention from the operator, once the start control has been activated. Such machines may be free-standing or included in a complex installation. Automatic control can apply to the operational sequence of a machine and its integrated equipment located permanently *in situ*, and to equipment which is mobile, including handling devices (e.g. piecing devices, automatic doffers).

General safety requirements

The safety requirements and/or measures in accordance with [Table 10](#) shall apply.

6.21.2 Automatic guards

Guards which can open and close automatically are fitted to automatic machines and equipment.

General safety requirements

The safety requirements given in [Table 10](#) for automatic machines and equipment (except [6.5](#) and [6.10](#)) shall apply.

Specific hazards

Mechanical, from the moving guards, in particular, crushing, shearing, drawing-in or trapping.

Specific risks

Intervention by exposed persons, particularly during special operations, leading to low probability of minor-to-severe injury.

Table 10 — General safety requirements relating to automatic machines and equipment

Application	Reference
All machines:	
Electrical equipment in general	5.4.2.1 and 5.4.2.2
Electrical control systems	5.4.2.3
Starting and stopping	5.4.2.4
Reduction of risks by design	5.3.2
Reduction of risks by safeguarding	5.3.3
— with guards	Table 2
— with safety devices	Table 3
Fluid power systems and components	5.4.5
Devices for special operation	5.5
Escape and rescue of trapped persons	5.7
Fitting of parts	5.8
Particular machine elements:	
Drive and transmission enclosures	6.2
Rollers	6.5
Rotating shafts	6.6
Running wheels	6.7.1
Conveyors	6.10

Specific safety requirements

In addition to the requirements given in [Table 10](#), one of the following measures shall be taken.

- a) Guards shall be made to open or close with a force which can be resisted by the operator without injury. This may be achieved by limiting the drive power to the guards (for pressure and force, see [A.4](#)).
- b) All edges of the guards which could give rise to the identified hazards shall be protected by sensitive protective equipment (e.g. pressure-sensitive edges) according to [Table 3](#) which, when operated, shall stop the movement of the guard.
- c) The danger zone around the guards shall be protected by sensitive protective equipment (e.g. pressure-sensitive mats and floors, and AOPDs), according to [Table 3](#), which prevent movement of the guards when an exposed person is present.

6.21.3 Mobile machines, handling devices, operational parts

Machines or sections of machines and handling devices which can move from one location to another automatically, generally along a defined track, or which can rotate, are found in many modern textile mills. Operational parts thereof move under automatic control.

General safety requirements

The safety requirements given in [Table 10](#) for automatic machines and equipment shall apply.

Specific hazards

Mechanical, in particular, crushing, shearing and impact between moving machines and fixed parts of adjacent machinery, plant or premises, etc., between moving handling devices or operational parts and adjacent fixed or moving machine parts, machinery, plant or premises.

Specific risks

Intentional or unintentional access by exposed persons during automatic operation and access during special operation, leading to high probability of minor-to-severe injury.

Specific safety requirements

- a) The machine or handling device or operational parts shall be designed in accordance with ISO 13854; or the pressure or force caused by the movement of a machine, handling device or operational parts shall not exceed the power of an exposed person in its path to resist the movement (see [A.4](#)).
- b) Where a) cannot be fulfilled, fence guards or safety devices shall be provided for moving machines. Fixed or movable enclosing guards or safety devices shall be provided for handling devices and operational parts to prevent access to the danger zones; or those sides of the machine, handling device or operational parts facing the direction of travel shall be protected by full-face sensitive protective equipment (e.g. trip plates, trip bars, pressure-sensitive edges, AOPD), according to [Table 3](#), designed to arrest the movement of the machine or handling device on contact before injury can occur.

When a safety device has been operated, the machine, handling device or operational parts may only be restarted by a deliberate act of the operator. Where the operator cannot view all the danger zones from the start control position, restart may only be possible after the operation of a reset control.

Alternatively, operation of a safety device may cause the direction of motion to reverse, if this in itself does not create a new hazard.

- c) Where handling devices are reprogrammable, they shall be in accordance with ISO 10218-1:2011, Clause 5.
- d) The instruction handbook shall give details of the clearance required around the mobile machine, handling devices or operational parts to prevent crushing and shearing prints between the mobile device and fixed parts of the factory or other machines.

6.21.4 Mobile machines and handling devices which could leave their defined path

General safety requirements

The safety requirements of [6.21.3](#) for mobile machines, handling devices and operational parts shall apply.

Specific hazards

Mechanical, in particular, crushing and impact when a moving machine or moving handling device leaves its defined path, due for example to failure of the control system, excessive speed or inadequate braking.

Specific risks

Unpredictable collision with exposed persons, leading to high probability of severe injury.

Specific safety requirements

One or the other of the following measures shall be taken.

- a) Stops (buffers) shall be provided at the ends of paths. The stops shall have sufficient absorption properties to counter the energy/velocity of the machine/handling device.
- b) The defined path (rail) shall be extended beyond the working length to allow the moving machine or handling device to come to rest following braking or removal of drive power.

6.21.5 Floor-mounted and overhead rails (tracks)

Floor-mounted rails and overhead rails are part of various textile machines to enable movement around the machine and the interaction with the machine of doffing, transport and cleaning devices.

Hazards

Mechanical, in particular, tripping over floor-mounted rails and impact from walking into overhead rails/tracks.

Risks

High probability of moderate injury at all times when access is needed to those areas beneath, or over, which the rails/tracks are located.

Safety requirements

- a) Floor-mounted rails shall be recessed in work areas and passageways.
- b) The rails/tracks shall have permanent high-visibility markings at all possible impact/tripping points.

6.21.6 Overhead transport of process material

Overhead transport of process material takes place in the working area of various textile machines.

Hazards

Mechanical, in particular, impact from falling packages of process material; and crushing, shearing and impact with suspended transiting devices and packages.

Risks

High probability of moderate injury, in particular, to the head, when passing beneath overhead transport systems.

Safety requirements

- a) The carrying devices shall hold the process material securely, independent of type and condition of cans, bobbins, tubes, beams, etc.
- b) Where the mass of packages is more than 5 kg, and their lower edge, when in the transport system, is more than 2 m above the ground, or where the mass is more than 3 kg and their lower edge is more than 2,5 m above the ground, either access to the area beneath the transport lines shall be prevented or catching devices shall be installed. These may be mounted on the transport devices themselves or may be stationary and installed under the line of the track.
- c) Overhead rails shall be installed so that clearance beneath the underside of suspended transiting devices or process material and floor level exceeds 1 850 mm, unless, at the actual point of operation (e.g. ring frame creel), it is required to be at a lower height, in which case,
 - 1) the conveying speed shall not exceed 15 m/min in the lowered section,
 - 2) there shall be no dangerous crush or shear points created by the passage of the device or material, and
 - 3) the rail shall rise to provide clearance exceeding 1 850 mm as rapidly as possible after the point of operation.

6.22 Complex installations

Hazards

Mechanical, from moving parts due to unexpected start-up of the whole line or parts thereof, or from the absence of guards for the interface between adjoining machines.

Risks

During normal operation when working at the interface between machines, and during special operation when working on any part of the installation, leading to high probability of severe injury.

Safety requirements

The installer/mannufacturer of the complex installation shall provide a power-supply disconnecting device (master isolator) for the entire complex installation and, where necessary, each machine or section thereof shall be provided with individual power-supply disconnecting devices, where these can be operated individually. This disconnecting device (master isolator) shall be lockable in the OFF position (see [5.4.2.4](#)).

The installer shall provide additional guards and safety devices in accordance with [5.3.3](#) as necessary for the complex installation in its entirety or in the interfaces between any given machine and those adjoining it.

All guards and safety devices shall be in position and activated before it is possible to start the entire complex installation for normal operation. Notwithstanding this, it is permitted to have guards and safety devices out of position or inactivated on any constituent machine while it is purposely inoperative and at a standstill, provided that access to dangerous parts on adjacent operating machines is prevented.

7 Verification of the compliance with the safety requirements and/or measures

The presence, proper application, or operation of the safety devices and/or measures set out in this part of ISO 11111 shall be verified using the methods given in Annex C.

Verification of the requirements defined in [Clauses 5](#) and [6](#) shall be applied to a machine in its operating condition, but partial dismantling could be necessary for the purpose of some checks.

Where reference is made to other standards, the methods of verification specified in those standards shall apply.

Noise emission values shall be determined in accordance with ISO 9902 (all parts). These values should be either those actually measured for the machinery in question or those established on the basis of measurements taken for technically comparable machinery, which is representative of the machinery to be produced.

8 Information concerning machine use

8.1 Signals and warning devices

Signals, warning devices and warning signs shall be provided to inform about the residual risks (see [Clauses 5](#) and [6](#)), in accordance with ISO 12100:2010, 6.4.3 und 6.4.4. Safety signs shall be in accordance with IEC 61310-1.

8.2 Accompanying documents (in particular: instruction handbook)

The instruction handbook shall be compiled in accordance with ISO 12100:2010, 6.4.5 and instructions regarding the electrical equipment shall be in accordance with [5.4.2.1](#) and [5.4.2.2](#).

Noise emission values shall be declared in accordance with ISO 9902 (all parts).

The manufacturer shall recommend the wearing of hearing protectors.

The information for use shall include all elements of information identified in the safety requirements and/or measures. This shall include the elements of training necessary to implement safe working practices correctly.

ISO 11111-1:2016(E)

The manufacturer shall provide information to the effect that

- a) the machines are to be operated by skilled persons, adequately trained,
- b) the machines are to be used with adequate workplace lighting according to EN 12464-1,
- c) components are to be kept in good repair, and
- d) operators are to wear hearing protectors, if necessary.

The information shall include the specifications of the spare parts to be used when these affect the health and safety of operators.

8.3 Marking

The machines shall be marked legibly and permanently with the following information:

- a) business name and full address of the manufacturer and, where applicable, his authorized representative;
- b) designation of the machinery;
- c) any mandatory marking¹⁾;
- d) year of construction (this is the year in which the manufacturing process is completed);
- e) designation of series or type, if any;
- f) serial or identification number, if any;
- g) rating information (mandatory for electrotechnical products: voltage, frequency, power, etc.).

1) For machines and their related products intended to be put on the market in EEA, CE marking as defined in the European applicable directive(s), e.g. Machinery, Low voltage, Explosive atmosphere, Gas appliances.

Annex A (normative)

Specifications

A.1 Crawl speed and reduced running speed

Crawl speed (see 3.3) and reduced running speed (see 3.4) are means of reducing risks in combination with the measures given in 5.5. They are limited by the values given in Tables A.1 and A.2, respectively.

Table A.1 — Crawl speed

Application	Max. speed m/min	Max. stopping distance mm
General	2	100
Exceptions		
Gill boxes	10	250
High draft finishers	10	250
Beaming of sectional warping	20	220
Beam warping	20	200
Beaming	20	220
Sizing	5	100
Circular knitting with rotating cam boxes	6	100
Flat bed knitting machines	6	100
Flat bed circular knitting machines	6	100
Dyeing and finishing machines:		
≤50 m/min normal speed	5	100
>50 m/min normal speed	15	100

Table A.2 — Reduced running speed

Application	Max. speed m/min	Max. stopping distance mm
General	Not constrained	100
Exception		
Dyeing and finishing machines: >50 m/min normal speed	Not constrained	200

A.2 Active opto-electronic protective devices (AOPDs)

Where AOPDs with several single beams are used to prevent entering a dangerous area, three beams shall be provided, at heights of 300 mm, 700 mm and 1 100 mm.

A.3 Fence guard

To prevent access to danger points, the dimensions of the fence guards shall be in accordance with ISO 13857. Additionally, the height shall be at least 1 800 mm and the clearance between the lower

edge of the fence guard and the floor shall not exceed 180 mm in order to reduce the possibility of unauthorized access.

Where doors are provided to permit access through the fence guard, they shall be interlocked. Where the stopping time exceeds the access time, guard locking shall be provided.

The machine may only be able to be restarted by actuating the start control at the control panel. To prevent restart by any unauthorized person, a reset control shall be provided near the door(s), from which all danger zones can be observed. Restart shall not be possible until the reset control has been actuated.

Alternatively, the SPE, such as pressure-sensitive mats or floors or an AOPD, may be used to prevent the machine being restarted as long as persons are within the fence guard. The safety-related part of the control system of the SPE shall have the same performance level (PL) or safety integrity level (SIL) as the safety-related system for the fence guard.

Doors shall be designed so that they can be opened from the inside.

If two or more doors are provided for access through the fence guard, each door shall be fitted with an independent reset control. The machine may only be restarted when all resets are clear.

If a risk analysis (according to ISO 12100 and ISO/TR 14121-2) indicates that severe injuries are to be expected, then the reset control shall be provided with independent locking means for each operator inside the guard. The machine may only be restarted when each operator has actuated his reset.

A.4 Pressure and force tolerable by the operator

No guard or safety device is necessary when pressure to which an operator can be exposed does not exceed 0,5 N/mm² and the force to which he can be exposed does not exceed 150 N, provided that no sharp edges are involved (see EN 953+A1). Where there are sharp edges, guards or safety devices shall be provided.

Annex B (normative)

Hot surfaces

To prevent burns by unintentional touching and without restriction of movement (contact period 0,5 s), the surface temperatures shown in [Table B.1](#) shall not be exceeded.

Table B.1 — Limits of surface temperature for a contact time of 0,5 s

Material	Specification		Temperature max. °C
	Coating	Thickness µm	
Uncoated metal	—		67
Coated metal	Lacquer	50	80
		100	89
		150	98
	Polyamide [Rilsan ^a]	400	103
	Enamel	160	73
	Powder	60	73
90		78	
Ceramics, stone, glass-like substances	—		84
Plastics	—		91
Wood	—		125

^a Rilsan® is an example of a suitable product available commercially. This information is given for the convenience of users of this document and does not constitute an endorsement by ISO of this product.

To prevent burns by intended contact, the surface temperatures shown in [Table B.2](#) shall not be exceeded.

Table B.2 — Limits of surface temperature for extended contact time

Contact time	Material	Temperature max. °C
4 s	Uncoated metal	58
	Coated metal	60
	Ceramics, glass, stone	71
	Plastics	76
	Wood	95
10 s	Uncoated metal	54
	Coated metal	54
	Ceramics, glass, stone	66
	Plastics	70
	Wood	85

Table B.2 (continued)

Contact time	Material	Temperature max. °C
1 min	Uncoated metal	51
	Coated metal	51
	Ceramics, glass, stone	56
	Plastics	60
	Wood	60
10 min	Uncoated metal	48
	Coated metal	48
	Ceramics, glass, stone	48
	Plastics	48
	Wood	48

Annex C (normative)

Verification methods

The methods of verification are presented in two tables:

- [Table C.1](#) classifies the different methods of verification and shows the designated codes used in [Table C.2](#);
- [Table C.2](#) is to be used for verification of the specific subclauses of this part of ISO 11111 and ISO 11111-2 to ISO 11111-7.

This provides a synoptic and systematic presentation of the large number of required verifications.

Table C.1 — Code and explanation of the different methods of verification used in [Table C.2](#)

Code No.	Item	Reference		Method of verification
		to this part of ISO 11111	to other standards	
A				Inspection: observe, compare and assess.
B				Measurement
C				Checking: actuate and then assess.
D				Testing: physical check with auxiliary equipment/instruments and resulting in a report.
F				Calculation
G				Comparison with the instruction handbook
H				Comparison with the technical file
E1	Fixed guard	—	EN 953+A1	Inspection and testing
		—	ISO 13857	Measurement
		A.3	—	Measurement
E2	Movable interlocking guard	E1	—	See above.
		—	ISO 14119	— Check that correct selection satisfies Clause 5 . — Check that the drive to the moving part or the actuator of a source of energy is switched off when opening or removing the guard and that restart is prevented when the guard is opened or removed.
		5.4.2.3	ISO 13849-1 or IEC 62061	Check Performance Level (PL) or check Safety Integrity Level (SIL).
		—	ISO 13849-1:2006, Clause 10 or IEC 62061:2005+A1:2012+A2:2015, Clause 10	Compare technical files.

Table C.1 (continued)

Code No.	Item	Reference		Method of verification
		to this part of ISO 11111	to other standards	
		A.3 (in addition, if there are doors in fence guards)	—	<ul style="list-style-type: none"> — Check that access time exceeds stopping time. — Check that the machine can be started only by actuating the start control on the control panel. — Check that the machine can be started only after actuation of the reset control (first alternative). — Check position of reset control. — Check that, when sensitive protective equipment is used, start-up is prevented in any position when a person enters the fence guard (second alternative). — Check that doors can be opened from inside. — Check that, when a door is shut, only the appropriate reset control is activated and that the reset controls are lockable if there is a risk of severe injury.
E3	Movable interlocking guard with guard locking	E1 and E2	—	See above.
		—	ISO 14119	Check that the guard cannot be opened or removed until the moving part has come to a standstill and start-up is prevented as long as the guard is open or removed and that protection remains even when the power supply is interrupted.
E4	Safety devices	—	ISO 13855	Check correct positioning by measurement.
E4.1	Sensitive protective equipment	5.3.3	IEC 61496-1:2012, Clauses 4 and 11	Check type.
		5.4.2.3	ISO 13849-1:2006, Clauses 7 and 9	Check Performance Level (PL).
E4.2	Pressure-sensitive edges and bars	5.4.2.3	ISO 13849-1 or IEC 62061	Check Performance Level (PL) or check Safety Integrity Level (SIL).
E4.3	Two-hand control	5.3.3	ISO 13851:2002, Clause 1 and Annex A	
		5.4.2.3	ISO 13849-1 or IEC 62061	Check Performance Level (PL) or check Safety Integrity Level (SIL).

Table C.1 (continued)

Code No.	Item	Reference		Method of verification
		to this part of ISO 11111	to other standards	
E4.4	Pressure-sensitive mats and floors	5.4.2.3	ISO 13849-1 or IEC 62061	Check Performance Level (PL) or check Safety Integrity Level (SIL).
E4.5	Hold-to-run control	5.3.3	ISO 12100:2010, 3.28.3	Check that the drive of the moving part is switched off when the hold-to-run control is released.
E4.6	Limited movement control	5.3.3	ISO 12100:2010, 3.28.9	— Check that the moving part, when the control is switched on, continues only one step and that this step does not exceed the distance stated in 5.5 c). — Check that in each case the next step is possible only after the moving part has stopped.

Table C.2 — Verification of specific subclauses of this part of ISO 11111 and other parts of ISO 11111

Subclause	Paragraph/Item no.	Method of verification
This part of ISO 11111		
5.3.2	Table 1	A, B, C and ISO 13854
5.3.3	Table 2 Table 3	E1, E2, E3 E4
5.4.2.2	Table 4	See IEC 60204-1:2005, Clause 18
5.4.2.3	1st paragraph and Table 5 2nd paragraph 3rd paragraph 4th paragraph 5th paragraph 6th paragraph	See Clauses in the International Standards referred to H H, G C A B, and see 5.4.2.4 for emergency stop control
5.4.2.4	1st paragraph and Table 6 a) b) c) d)	See Clauses in the International Standards referred to A A, D A, C A
5.4.4	3rd paragraph 4th paragraph: a) b) c)	Check supplier's information A B G
5.4.6.1		A, B, D, G
5.4.6.2		A, B, C, G and E2 for interlocking
5.4.7		B, see ISO 9902 (all parts) as amended C, check that appropriate noise control reduction measures were applied
5.4.8		See Clauses in the International Standard referred to
5.4.9		See Clauses in the International Standard referred to
5.4.10		A, G, see verification in ISO 14123-1 and ISO 14123-2
5.4.11	a), b)	A, C, G, H

Table C.2 (continued)

5.4.12		For dust: C, G For flammable liquids, see verification in EN 1127-1
5.4.13		A, G, see Clauses in the International Standards referred to
5.5	1st to 4th paragraphs and Table 8 , 5th paragraph: a) b) c) d) e) 6th paragraph 7th paragraph	A, C, G C H, A, C B, C B, C A C G
5.6		A, G
5.7		G, C
5.8		A, C
6.2	a) b) c) d) 1) 2) 3) e)	E1 A E1, E2 C, E4, E4.5 A, C, E4 A, C G
6.3	a) b) 1) 2) 3) c) d) e) f)	E1, E2, E3 By questioning purpose of fixed guards B B, C E3 E1, E2, E3 See 5.5 C H
6.4.1		G, H, check the risk assessment
6.4.2		G, H
6.5	a) b) c) d) e) f) g) h) i) j) k)	B, A C, check with “head size” test piece and H, check the risk assessment Guards: A, B, E1, E2, E3 Safety devices: E4, E4.1 to E4.5 Separation of rollers: B, C For AOPDs fitted in front of drawing-in point: C Check with “hand-like” test piece C, check in accordance with a) to c) B, C, and see a) or c) C A and B, compare with Annex D Guards and safety devices: E1, E2, E4 For AOPDs, check with “hand-like” test piece E1, E2 E1, E2 See 5.5 H
6.6	a) b) c) d)	B E1 A B

Table C.2 (continued)

6.7.1	a) b)	A, C E4.1
6.7.2		A
6.8.2	a) 1) 2) 3) b) c) 1) 2) 3)	A A A, F A, C B A, E4, E4.2 A, E4, E4.5
6.8.3	1st paragraph 2nd paragraph 3rd paragraph: a) b) c) 1) 2) 3)	A, C A, B, C C, ISO 14119 B, C A, C, E3, ISO 14119 C, E3, ISO 14119 A, F
6.8.4	a) b) c)	E2, E3 A, E4, E4.5 A
6.9		H, E1, E2, E3
6.10	a) b) c) d) e)	B A, E1 and E2 A, E1 See 6.5 c) A
6.11	a) b) c)	A, B, E1 B, C, E3, G A
6.12	a) b) c) d)	A, E1 A, C, E1, E4, E4.1 A, B, C, D1, E2, E4, E4.1, E4.4, H See 6.3
6.13	a) b)	ISO 14122-1 to ISO 14122-4, E1, E2, E3, E4 A, B
6.14	a) b) c) d)	A A, C A, C G
6.15	1st paragraph 2nd paragraph of the specific safety requirements	A, B A, C
6.16	a) b) c) d)	A A, C A, and see ISO 14119:2013, Clause 7 C
6.17	a) b) c)	A, E1 A, E2 A, C
6.18.1		A, E2, E4, E4.5, E4.6 H

Table C.2 (continued)

6.18.2		B, C, E2, E4, E4.1, E4.5
6.18.3		A, E4, E4.1
6.18.4		A, C, E4.1, E4.2, E4.4
6.18.5		A, C, H, E.1, E.2, E4, E4.1 A, C, E4.5
6.19	a) 1) 2) b) c) 1) 2) 3) d)	A, E1 A, E3 A, C A, E1 to E3 A, E4.5 A, ISO 13850, ISO 12100:2010, 6.4.3 H
6.20		A
6.21.2	a) b) c)	A, B, C A, C, E4, E4.1, E4.2 A, C, E4, E4.1, E4.4
6.21.3	a) b) c) d)	B A, C, E1, E2, E4, E4.1 See ISO 10218-1:2011, Clause 5 G
6.21.4	a) b)	A, C A, C
6.21.5	a), b)	A
6.21.6	a) b) c)	A A, B A, B
6.22		A, C, E1, E2, E3, E4
ISO 11111-2:2005, ISO 11111-2:2005/Amd 1:2009, ISO 11111-2:2005/Amd 2:2016		
5.2.1		E3
5.2.2	a), b) c) d) e) f) g)	E1, E2, E3, E4, H A A, see ISO 14118:2000, 7.1 B, G C See 6.71
5.2.3	a) b)	A, B E3
5.2.4	a) b)	C, E2, E3, see ISO 14119 and ISO 13857 A, C, E4, E4.1

Table C.2 (continued)

5.2.5	a), b) c) 1) 2) 3) d) 1) 2) 3) e) f) g) h)	C, E1, and see ISO 14119 A, E1 A, E4.1, see 6.7.1 A, E4.5, see 6.7.1 A, E4.5 A, E4.1 B A, C, E2, E4.4, E4.5, and see 6.7.1 A, E2 A, F G, B
5.3	a) b)	E1 E1, B
5.4	a) 1) 2) 3) b) c) d) 1) 2) e) f) g) h) 1) 2) 3) 4) i) j) k) l)	E1 E2 B A, E2 C A, C, E2 C C A, B A A E2 E2, and see IEC 61496-1:2012, Clause 11, E4.2, E4.5 C E4.5 A A, G H
5.5.1	a) b) c)	E3 C, E2, E3 G
5.5.2		C, E3
5.5.3	a) b) c) d) e)	B, E3, C E3, G A, B A, E1 A
5.5.4	a) b)	A, B, C, E2, E4.1 C, E3, E4.1
5.6	a) b) c) d)	A, B, E2, E4, E4.5, E4.6 C, E4.2 C H
5.7.1		C
5.7.2		C, E2, E4.5, E4.6, H

Table C.2 (continued)

5.7.3	a) 1) 2) b) c)	B, E4.5, E2, C B, E4.6, E2, C C E1, E2
5.7.4	a) b) c) d)	E1, E2 C A, C See 6.19
5.7.5		E3
5.7.6		E2, E4.5, E4.6
5.7.7	a) b) 1) 2) 3) c) d)	A, E2, G B, E4.5 C, E4.6 C, E4 A, E1 A,
5.7.8	a) b)	B, E2, E4.5, E4.6, C, H E1
5.7.9	1st paragraph 2nd paragraph a) b) 3rd paragraph 4th paragraph	E2 B, C, E4.5 B, C, E4.6 G C
5.7.10	a) b) c) d) e)	A, B, and see ISO 13854, E1, E4.1, E4.5 C, E2, E3, E4 A G
5.8.2	a) b) c) d)	G E4.1 A, E1, E2, E4 A
5.8.3	a) b)	G E4.1
ISO 11111-3:2005, ISO 11111-3:2005/Amd 1:2009, ISO 11111-3:2005/Amd 2:2016		
5.3	a) b) c) d) e)	A, E1, E3 E1, B A, see 6.10 A, see 6.7 A, E1, see 6.5
5.4	a) b)	A, C, E4, E4.1, E4.2 A, C, E2
ISO 11111-4:2005, ISO 11111-4:2005/Amd 1:2009, ISO 11111-4:2005/Amd 2:2016		
5.2	a) b) c)	E1, see ISO 11111-2:2005, 5.7.8 (as amended by ISO 11111-2:2005/Amd 1:2009 and ISO 11111-2:2005/Amd 2:2016) and 5.5.2.1 A, I G
5.3	a) b) c), d)	G C, E4.1, E4.2 C, E1, E2

Table C.2 (continued)

5.4	a) b) c) d)	A, E1, E2, E4, E4.1 A, E1, E2, E4, E4.1 A, E1, E2, E4, E4.1 and see 6.2.1 A, E1, E2, E4
5.5.2.1	a) b)	C A, E1
5.5.2.2		A, E1, E2, E3, C
5.5.2.3		E1, E2
5.5.3	a) b) c)	B, E1 E1, E2 B, E1
5.5.4	a) b)	E1, E4.1 B, E1
5.5.5		G
5.5.6		E1, E2
5.6	a) b) c) d)	A, B, C, E1 A, B, E1 A, E1, E2, E3 A, E2, E3
ISO 11111-5:2005, ISO 11111-5:2005/Amd 1:2009, ISO 11111-5:2005/Amd 2:2016		
5.2	a) b) 1) 2) 3) c) 1) 2) d) e) f)	E2 B, E2 E4.1, C, A E2, A, C A, C, E4.5 A, C A, E1 C, H G, H
5.3.2	a) b) c)	A, E1, E2, E4.5 and see Table 3 A, C, see Table 3 G
5.3.3	a) b) 1) 2) c)	A, E2, E4.5, see Table 3 B, E1, E2 E2, E4.5, C, B A, E4.4, E4.5, B G
5.4	a) b)	A, B, E3 A, B, C, E3
5.5	a) b) c)	A, F, H A E1
ISO 11111-6:2005, ISO 11111-6:2005/Amd 1:2009, ISO 11111-6:2005/Amd 2:2016		
5.2.1	a) b) c)	A A, E2, E4, E4.1, E4.3 A, E1, E2, E4.1, H
	d) e) f) g), h) i) j) k)	A, C, G A, C, G A, B G H A, C H

Table C.2 (continued)

5.2.2	a) b) c)	C, E1 A, E1 B, E1
5.2.3	a) b)	E2, E4, E4.1 E1
5.2.4		C, G
5.2.5		E4.1
5.2.6	a) b)	C G
5.2.7		E1, E2
5.2.8	a) b) c) d) e), f) g)	E1 B A, E1 C C, E4.5 G
5.2.9	a) b) c) d) e) f)	A, C, G A, C, G E1 G A G
5.3.2	a) b) c)	E1, E2 C, E1, E2, E4.1, E4.2 A, B
5.3.3	a) b) c)	C, E2, E4.5 A, G E1
5.3.4	a) b) c) d) e) f)	A, G E1, E4, E4.1 E1, E2 A, B, G, see 6.5 G A, B, G, see 6.13 d)
5.4	a) b) c) d)	A B, E2 E1 A
5.5		A, E1, E2, F, H
ISO 11111-7:2005, ISO 11111-7:2005/Amd 1:2009, ISO 11111-7:2005/Amd 2:2016		
5.1.2		A, C, G, E4.1
5.2.2		E1, E3
5.2.3	a) b) c)	C, E3 A B, C
5.2.4	a) b) c)	C, H A E1
5.2.12	a) b) c)	A, C, H, see ISO 14119 C, see ISO 14119 B A, C
5.3.2	a) b)	A, G A, E1

Table C.2 (continued)

5.3.3	a) b) c) d) e)	C, and see ISO 14119 A A, C G H
5.3.5	a) b)	H B, C, E2, E4, E4.1, E4.5 C, G
5.3.8	a) b)	B, C, E2, E4, E4.5, E4.6 A, E4.5
5.4.2	a) b)	A B, E1
5.4.3	a) b)	A, E4.1 G
5.4.5	a) b)	A A, E1, E2
5.5.4		E1
5.5.6		E1, E2
5.5.7	a) b)	A, E1 G
5.6.2	a) b) c)	C (for reverse running) E4.5 H
5.6.3	a) 1) 2) 3) b)	E2 C C B, E4.5 E2
5.6.4		A
5.6.5	a) 1) 2) 3) 4) 5) b)	E3 C, E4.6 C B A A B, C
5.6.7	a), b)	A, E1
5.6.8	a) b)	C, E2, H, and see ISO 14119 B, C, H
5.6.10		B, C, E3
5.6.11		E3

Annex D (normative)

Nip between roller and fabric

Drawing-in points between roller and on-running uncoated woven or knitted fabric need not be safeguarded, provided at least all of the following conditions are met.

- a) The angle of wrap does not exceed 90° for woven fabrics and 180° for knitted fabrics. This applies both to wet and dry fabrics.
- b) The mass per unit area is less than 200 g/m^2 .
- c) The fabric tension in relation to the width of fabric is 300 N/m maximum for woven fabrics and 20 N/m maximum for knitted fabrics.
- d) The diameter of the roller is at least 80 mm .
- e) The roller surface is smooth or slightly structured but not rough (e.g. there is no abrasive coating).
- f) The fabric speed is 100 m/min maximum.
- g) The drawing-in point between roller and on-running fabric is not situated in front of an adjacent drawing-in point between rollers.
- h) The roller is driven only by the fabric.

Annex E (informative)

List of machines and equipment used in the textile industry but not within the scope of this part of ISO 11111

**Table E.1 — List of machines and equipment used in the textile industry
not covered by this part of ISO 11111**

Machines and/or equipment	Reference
Centrifuges	EN 12547
Rail dependant storage equipment	EN 528
Extruders	EN 1114-1
Handling and lifting devices	EN 1459, ISO 3691-1
Robots	ISO 10218-2
Automated vehicles	EN 1525, EN 1526
Hydraulic and pneumatic presses	EN 693, EN 13736

Bibliography

- [1] ISO 5232, *Graphical symbols for textile machinery*
- [2] ISO 10218-2, *Robots and robotic devices — Safety requirements for industrial robots — Part 2: Robot systems and integration*
- [3] ISO 3691-1, *Industrial trucks — Safety requirements and verification — Part 1: Self-propelled industrial trucks, other than driverless trucks, variable-reach trucks and burden-carrier trucks*
- [4] ISO 13856-1, *Safety of machinery — Pressure-sensitive protective devices — Part 1: General principles for design and testing of pressure-sensitive mats and pressure-sensitive floors*
- [5] ISO 13856-2, *Safety of machinery — Pressure-sensitive protective devices — Part 2: General principles for design and testing of pressure-sensitive edges and pressure-sensitive bars*
- [6] ISO 13856-3, *Safety of machinery — Pressure-sensitive protective devices — Part 3: General principles for design and testing of pressure-sensitive bumpers, plates, wires and similar devices*
- [7] EN 528, *Rail dependent storage and retrieval equipment — Safety requirements*
- [8] EN 693, *Machine tools — Safety — Hydraulic presses*
- [9] EN 1114-1, *Rubber and plastic machines — Extruders and extrusion lines — Part 1: Safety requirements for extruders*
- [10] EN 1459+A2, *Safety of industrial trucks — Self-propelled variable reach trucks*
- [11] EN 1525, *Safety of industrial trucks — Driverless trucks and their systems*
- [12] EN 1526+A1, *Safety of industrial trucks — Additional requirements for automated functions on trucks*
- [13] EN 12547, *Centrifuges — Common safety requirements*
- [14] EN 13736, *Safety of machine tools — Pneumatic presses*
- [15] Report C.E.N.E.L.E.C. R044-001:1999, *Safety of machinery: Guidance and recommendations for the avoidance of hazards due to static electricity*

