Photography — Slide trays for projectors —

Part 1:

Straight slide tray, open type (European design)

Photographie — Paniers chargeurs de diapositives pour projecteurs —

Partie 1: Panier chargeur droit de diapositives, type ouvert (conception européenne)



Foreword

ISO (the International Organization for Standardization) is a worldwide federation of national standards bodies (ISO member bodies). The work of preparing International Standards is normally carried out through ISO technical committees. Each member body interested in a subject for which a technical committee has been established has the right to be represented on that committee. International organizations, governmental and non-governmental, in liaison with ISO, also take part in the work. ISO collaborates closely with the International Electrotechnical Commission (IEC) on all matters of electrotechnical standardization.

Draft International Standards adopted by the technical committees are circulated to the member bodies for voting. Publication as an International Standard requires approval by at least 75 % of the member bodies casting a vote.

International Standard ISO 11106-1 was prepared by Technical Committee ISO/TC 42, *Photography*.

ISO 11106 consists of the following parts, under the general title *Photography — Slide trays for projectors*:

- *Part 1: Straight slide tray, open type (European design)*
- *Part 2: Straight slide tray, closed type (Japanese design)*

Annex A of this part of ISO 11106 is for information only.

© ISO 1997

All rights reserved. Unless otherwise specified, no part of this publication may be reproduced or utilized in any form or by any means, electronic or mechanical, including photocopying and microfilm, without permission in writing from the publisher.

International Organization for Standardization
Case postale 56 • CH-1211 Genève 20 • Switzerland
Internet central@iso.ch
X.400 c=ch; a=400net; p=iso; o=isocs; s=central

Printed in Switzerland

Photography — Slide trays for projectors —

Part 1:

Straight slide tray, open type (European design)

1 Scope

This part of ISO 11106 specifies the essential dimensions of a straight slide tray, open type (European design), for projector slides of the preferred international nominal size 5 cm × 5 cm complying with ISO 1755, with a capacity of 36 slides or 50 slides. It includes a testing gauge for checking the tray profile and gear system.

In this design, the slide tray is placed upright into the projector and the slides are lifted approximately 9 mm out of the tray and then pushed sideways into the projector. Slides remain fully accessible when the tray is inserted in the projector and can be removed and reinserted.

This part of ISO 11106 is intended to facilitate the manufacture, use and interchangeability of straight slide trays in different slide projectors which are designed for this type of tray.

2 Normative references

The following standards contain provisions which, through reference in this text, constitute provisions of this part of ISO 11106. At the time of publication, the editions indicated were valid. All standards are subject to revision, and parties to agreements based on this part of ISO 11106 are encouraged to investigate the possibility of applying the most recent edition of the standards indicated below. Members of IEC and ISO maintain registers of currently valid International Standards.

ISO 53:1974, *Cylindrical gears for general and heavy engineering — Basic rack.*

ISO 1622-1:1994, *Plastics — Polystyrene (PS) moulding and extrusion materials — Part 1: Designation system and basis for specifications.*

ISO 1755:1987, *Photography — Projector slides — Dimensions.*

ISO 2768-1:1989, *General tolerances — Part 1: Tolerances for linear and angular dimensions without individual tolerance indications.*

3 Capacity

The capacity of the straight slide tray, open type, shall be either 36 slides or 50 slides.

4 Dimensions

4.1 Details which are not mentioned should be selected in accordance with their purpose. Dimensions without tolerance indications are in accordance with ISO 2768-1 (tolerance class: medium).

4.2 The spacing dimension $5,5 \pm 0,05$ mm determines the distance between the centres of the tooth spaces for the two-toothed racks and the distance between the slots in the lower side wall.

4.4 The flank dimensions of the shortened first and last tip of tooth (see detail Y, dimension 1 mm in figure 1) shall not deviate, in order to guarantee trouble-free functioning when inserting the straight tray into the tray track. At least the joint at the dimension 1 mm shall be within the flank tolerance.

4.5 Just like the tolerated deviations of the guiding elements, all slants and roundings dimensioned in the details and cross-sectional drawings are important for the functioning of the slide change and shall be strictly adhered to.

4.6 Printing areas and inscriptions on friction surfaces, such as manufacturer's markings, shall always be sunk. Inscriptions outside the marked areas shall not lead to change in the functional dimensions.

NOTE — The dimensions and tolerances of the straight tray are adjusted to those of the slide projector. The different dimensions are inter-dependent with regard to the function in the slide projector.

4.7 The limit deviations and fleet angles which serve to open the mould may only be used to an extent which does not result in difficulties. For example, when lining up successive straight trays in the projector (tray line-up, see figure 2), the step size l_3 of $5,5 \text{ mm} \pm 0,05 \text{ mm}$ to the next slide compartment and the tooth, respectively, shall be respected. For the total mean deviation, however, limiting values of $\pm 0,3 \text{ mm}$ apply (see dimension l_1 in table 1 and figure 2).

Dimensions in millimetres

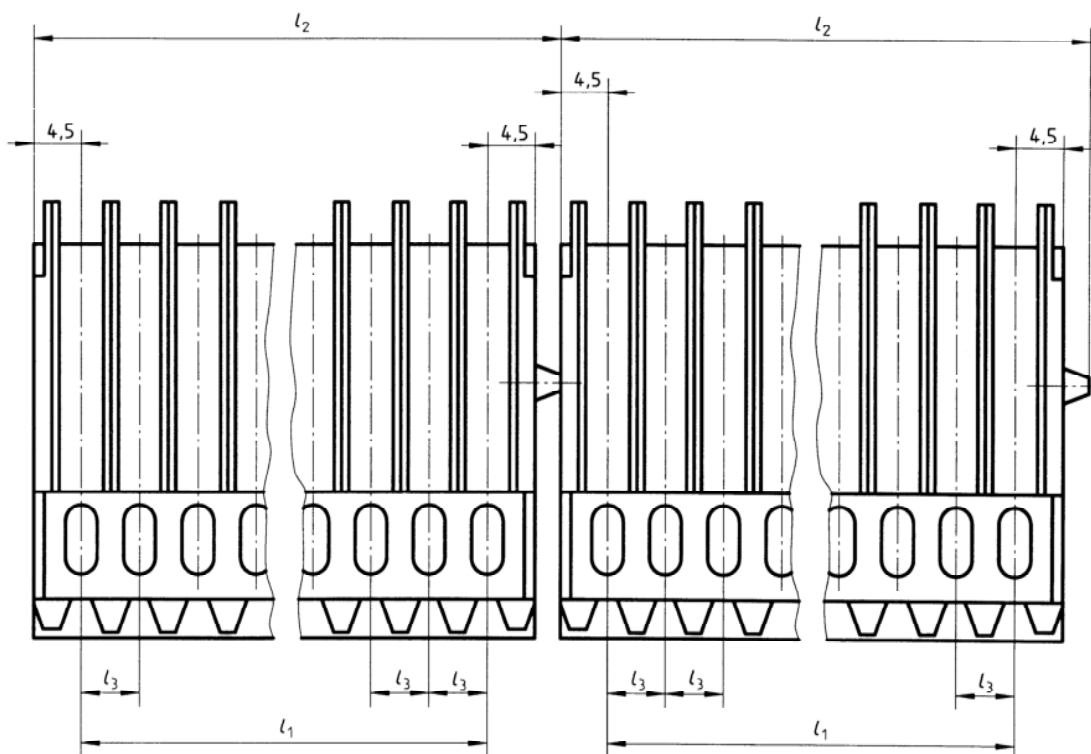

Key

l_1 Total step

l_2 Total length

Figure 2 — Tray line-up

Table 1 — Spacing dimension and total length

Tray type	l_1 , mm	l_2 , mm
Stray tray 5 × 5 – 36	$192,5 \pm 0,3 =$ $35 \times (5,5 \pm 0,05)$	$203,5 \pm 0,5$
Stray tray 5 × 5 – 50	$296,5 \pm 0,3 =$ $49 \times (5,5 \pm 0,05)$	$280,5 \pm 0,5$

5 Material

Moulding material made of plastic, such as “polystyrene” moulding batch, ISO 1622-PS 41 or another moulding material with the same heatproof quality shall be selected by the manufacturer.

6 Gauge to verify dimensions

The use of a gauge is recommended for checking the tray profile and gear system of straight slide trays, open type, 5 × 5 – 36 and 5 × 5 – 50.

6.1 Dimensions

Details which are not mentioned should be selected in accordance with their purpose. Dimensions without tolerance indications are in accordance with ISO 2768-1 (tolerance class: medium).

6.2 Material and design

6.2.1 Material

Gauge steel, quality to be selected by the manufacturer or as agreed upon.

6.2.2 Surface

Friction and rolling surfaces shall not exceed a mean peak-to-valley height R_z of 2,5 mm.

6.2.3 Gear system

Straight gear system (see annex A).

Profile displacement factor $x = 0,352$.

Module $m = 1,75$.

Number of teeth $z = 8$.

Profile angle in accordance with ISO 53.

6.3 Testing of tray profile and gear system

The straight tray should pass through and roll off in a horizontal position with a maximum force of 5 N.

To check the tray profile and gear system separately, the gauge may be constructed so as to allow a displacement of each gear in the axial direction from the zone of contact.

7 Product marking and labelling

The marking of a straight slide tray, open type, for slides of nominal size 5 cm × 5 cm with a capacity of 36 slides shall be as follows:

Straight slide tray, open type, ISO 11106-1 – 5 × 5 – 36

The marking of a straight slide tray, open type, for slides of nominal size 5 cm × 5 cm with a capacity of 50 slides shall be as follows:

Straight slide tray, open type, ISO 11106-1 – 5 × 5 – 50

Dimensions in millimetres

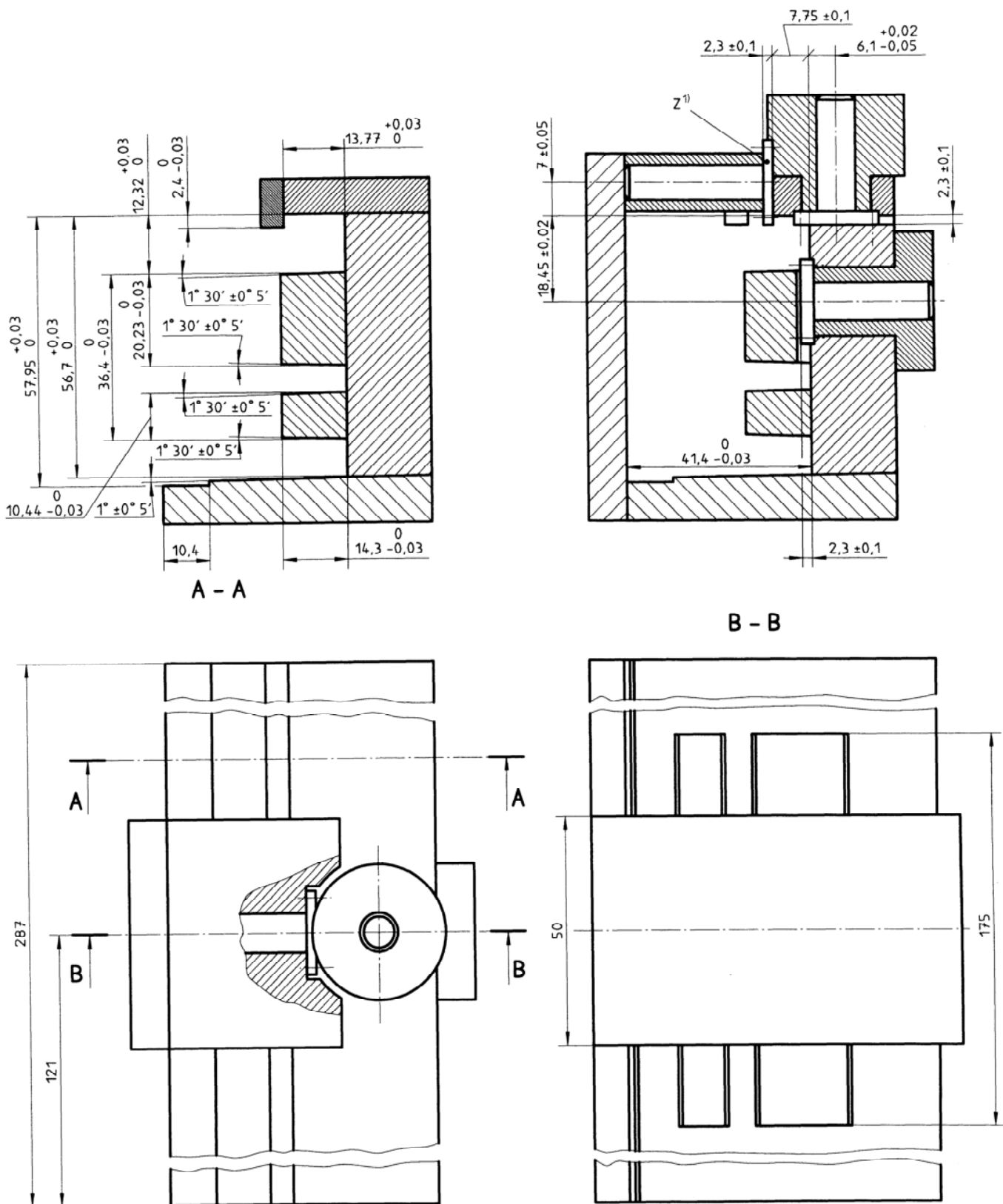

1) The toothed gear marked Z is used for controlling the lateral perforation of the straight tray under test. It corresponds to the mode of transportation in different slide projectors.

Figure 3 — Gauge

Annex A

(informative)

Bibliography

- [1] ISO 11106-2:1997, *Photography — Slide trays for projectors — Part 2: Straight slide tray, closed type (Japanese design)*.
- [2] DIN 3992:1964, *Addendum modification of external spur and helical gears*.
- [3] DIN 3994:1964, *Addendum modification of straight spur gears in the 05-system — Introduction*.

This page intentionally left blank

This page intentionally left blank

This page intentionally left blank

ICS 37.040.10

Descriptors: photography, photographic equipment, slide projectors, slide trays, specifications, dimensions.

Price based on 6 pages
