

INTERNATIONAL STANDARD

ISO
11064-3

First edition
1999-12-15

Ergonomic design of control centres — **Part 3:** **Control room layout**

Conception ergonomique des centres de commande —
Partie 3: Agencement de la salle de commande



Reference number
ISO 11064-3:1999(E)

© ISO 1999

PDF disclaimer

This PDF file may contain embedded typefaces. In accordance with Adobe's licensing policy, this file may be printed or viewed but shall not be edited unless the typefaces which are embedded are licensed to and installed on the computer performing the editing. In downloading this file, parties accept therein the responsibility of not infringing Adobe's licensing policy. The ISO Central Secretariat accepts no liability in this area.

Adobe is a trademark of Adobe Systems Incorporated.

Details of the software products used to create this PDF file can be found in the General Info relative to the file; the PDF-creation parameters were optimized for printing. Every care has been taken to ensure that the file is suitable for use by ISO member bodies. In the unlikely event that a problem relating to it is found, please inform the Central Secretariat at the address given below.

© ISO 1999

All rights reserved. Unless otherwise specified, no part of this publication may be reproduced or utilized in any form or by any means, electronic or mechanical, including photocopying and microfilm, without permission in writing from either ISO at the address below or ISO's member body in the country of the requester.

ISO copyright office
Case postale 56 • CH-1211 Geneva 20
Tel. + 41 22 749 01 11
Fax + 41 22 734 10 79
E-mail copyright@iso.ch
Web www.iso.ch

Printed in Switzerland

Contents

	Page
1 Scope	1
2 Normative references	1
3 Terms and definitions	1
4 Ergonomic design of control centres	5
4.1 Process for control room layout	5
4.2 General considerations for control room layout	6
4.3 Architectural/building recommendations	9
4.4 Workstation arrangements	13
4.5 Shared visual displays, off-workstation	15
4.6 Personnel circulation and maintenance access	17
Annex A: Examples of control room layout	22
Annex B: Anthropometric data of the world population:	34
Bibliography	35

Foreword

ISO (the International Organization for Standardization) is a worldwide federation of national standards bodies (ISO member bodies). The work of preparing International Standards is normally carried out through ISO technical committees. Each member body interested in a subject for which a technical committee has been established has the right to be represented on that committee. International organizations, governmental and non-governmental, in liaison with ISO, also take part in the work. ISO collaborates closely with the International Electrotechnical Commission (IEC) on all matters of electrotechnical standardization.

International Standards are drafted in accordance with the rules given in the ISO/IEC Directives, Part 3.

Draft International Standards adopted by the technical committees are circulated to the member bodies for voting. Publication as an International Standard requires approval by at least 75 % of the member bodies casting a vote.

Attention is drawn to the possibility that some of the elements of this International Standard may be the subject of patent rights. ISO shall not be held responsible for identifying any or all such patent rights.

International Standard ISO 11064-3 was prepared by Technical Committee ISO/TC 159, *Ergonomics*, Subcommittee SC 4, *Ergonomics of human-system interaction*.

ISO 11064 consists of the following parts, under the general title *Ergonomic design of control centres*:

- *Part 1: Principle for the design of control centres.*
- *Part 2: Principles of control suite arrangement*
- *Part 3: Control room layout*
- *Part 4: Workstation layout and dimensions*
- *Part 5: Displays and controls*
- *Part 6: Environmental requirements for control centres*
- *Part 7: Principles for the evaluation of control centres*
- *Part 8: Ergonomic requirements for specific applications*

Annexes A and B of this part of ISO 11064 are for information only.

Introduction

This part of ISO 11064 establishes ergonomic requirements, recommendations and guidelines for control room layout.

User requirements are a central theme of this part of ISO 11064 and the processes described are designed to take account of needs of users at all stages. The overall strategy for dealing with the user requirements as strategy to be adopted for control room design is presented in ISO 11064-1.

ISO 11064-2 provides guidance on the design and planning of the control room in relation to its supporting areas. Requirements for the design of workstations, displays and controls and the physical working environment are presented in ISO 11064-4 to ISO 11064-6. Evaluation principles are dealt with in ISO 11064-7.

ISO 11064-1 to ISO 11064-7 cover general principles of ergonomic design appropriate to a range of industries and service providers. The specific requirements appropriate to particular sectors or applications areas are covered in ISO 11064-8. The requirements presented in ISO 11064-8 are to be read in conjunction with ISO 11064-1 to ISO 11064-7.

The ultimate beneficiaries of this part of ISO 11064 will be the control room operator and other users. It is the needs of these users that provide the ergonomic requirements used by the developers of International Standards. Although it is unlikely that the end user will read this part of ISO 11064, or even know of its existence, its application should provide the user with interfaces that are more usable and a working environment which is more consistent with operational demands. It should result in a solution which will minimize error and enhance productivity.

For determining design dimensions, the practice of providing formulae, into which appropriate user population data is inserted, is adopted. A table of anthropometric data is presented in annex B.

Ergonomic design of control centres —

Part 3: Control room layout

1 Scope

This part of ISO 11064 establishes ergonomic principles for the layout of control rooms. It includes requirements, recommendations and guidelines on control room layouts, workstation arrangements, the use of off-workstation visual displays and control room maintenance.

It covers all types of control centres, including those for the process industry, transport and dispatching systems in the emergency services. Although this part of ISO 11064 is primarily intended for non-mobile control centres, many of the principles could be relevant/applicable to mobile centres, such as those found on ships and aircraft.

2 Normative references

The following normative documents contain provisions which, through reference in this text, constitute provisions of this part of ISO 11064. For dated references, subsequent amendments to, or revisions of, any of these publications do not apply. However, parties to agreements based on this part of ISO 11064 are encouraged to investigate the possibility of applying the most recent editions of the normative documents indicated below. For undated references, the latest edition of the normative document referred to applies. Members of ISO and IEC maintain registers of currently valid International Standards.

ISO 7250:1996, *Basic human body measurements for technological design*.

ISO 9241-3:1992, *Ergonomic requirements for office work with visual display terminals (VDTs) — Part 3: Visual display requirements*.

ISO 9241-5:1998, *Ergonomic requirements for office work with visual display terminals (VDTs) — Part 5: Workstation layout and postural requirements*.

ISO 11428:1996, *Ergonomics – Visual danger signals – General requirements, design and testing*.

3 Terms and definitions

For the purposes of this part of ISO 11064, the following terms and definitions apply.

NOTE To assist with the interpretation of these definitions, descriptive Figures 1 and 2 are included in this clause.

3.1

control centre

combination of control rooms, control suites and local control stations which are functionally related and all on the same site (see Figure 1)

- 3.2**
control console
structural framework which supports equipment, worksurfaces and storage and which together comprise a control workstation
- 3.3**
control panel
discrete surface on which groups of displays and controls are mounted; control panels may be mounted on the control workstation or on walls (see Figure 2)
- 3.4**
control room
core functional entity, and its associated physical structure, where control room operators are stationed to carry out centralized control, monitoring and administrative responsibilities
- 3.5**
control room operator
individual whose primary duties relate to the conduct of monitoring and control functions, usually at a control workstation, either on their own or in conjunction with other personnel both within the control room or outside
- 3.6**
control suite
group of functionally related rooms, co-located with the control room, and including it, which house the supporting functions to the control room, such as related offices, equipment rooms, rest areas and training rooms (see Figure 1)
- 3.7**
control workstation
single or multiple working position, including all equipment such as computers and communication terminals and furniture at which control and monitoring functions are conducted (see Figure 2)
- 3.8**
direct operator supervision
supervision of control room operators, and other staff, by direct observation and/or via direct speech links
- 3.9**
display
device for presenting information that can change with the aim of making things visible, audible or discriminable by tactile or proprioceptive perception
- 3.10**
functional groups
grouping of control workstations where the operational duties are such that close, direct liaison is required and therefore benefit from proximity to one another
- 3.11**
functional layout
layout in which the general location of differing control functions in a control room are indicated
- 3.12**
gross area
overall number of square metres designated for a control room
- 3.13**
disability
any reduction in normal capacity due to mental or physical factors which prevents an individual from experiencing or performing a full complement of activities [8]
- 3.14**
intimate zone
distance at which the presence of another person is unmistakable through such factors as sight, olfaction, heat and sound

3.15**local control station**

operator interface that is located near the equipment or system being monitored and/or controlled

3.16**off-workstation display**

displays which are not mounted on the control workstation; such displays, often visual, may be display panels, mimic diagrams and observation windows (see Figure 2)

3.17**primary information**

information which is essential for the satisfactory exercise of control functions

3.18**primary workstation**

control workstation that is usually staffed and is in the main control area

3.19**secondary information**

information which is either of secondary importance to the control function or which does not need to be immediately available to the control room operator

3.20**secondary workstation**

workstation on which supportive tasks are undertaken, or on which an overload of tasks can be carried out during periods of peak workloads

3.21**shared visual display device**

on-workstation visual display which needs to be used by more than one control room operator while they are at their control workstations

3.22**stature (body height)**

vertical distance from the floor to the highest point of the head (vertex)

[ISO 7250:1996]

3.23**supervisor**

individual whose primary responsibilities relate to the satisfactory conduct of control functions by the control room, the supervision of staff and equipment and, when necessary, the conduct of control tasks

3.24**task analysis**

analytical process employed to determine the specific behaviours required of people when operating equipment or doing work

[ISO 9241-5:1998]

3.25**usable area**

gross area less deduction for unusable spaces, such as around pillars, awkward corners and nearby entrances/exits

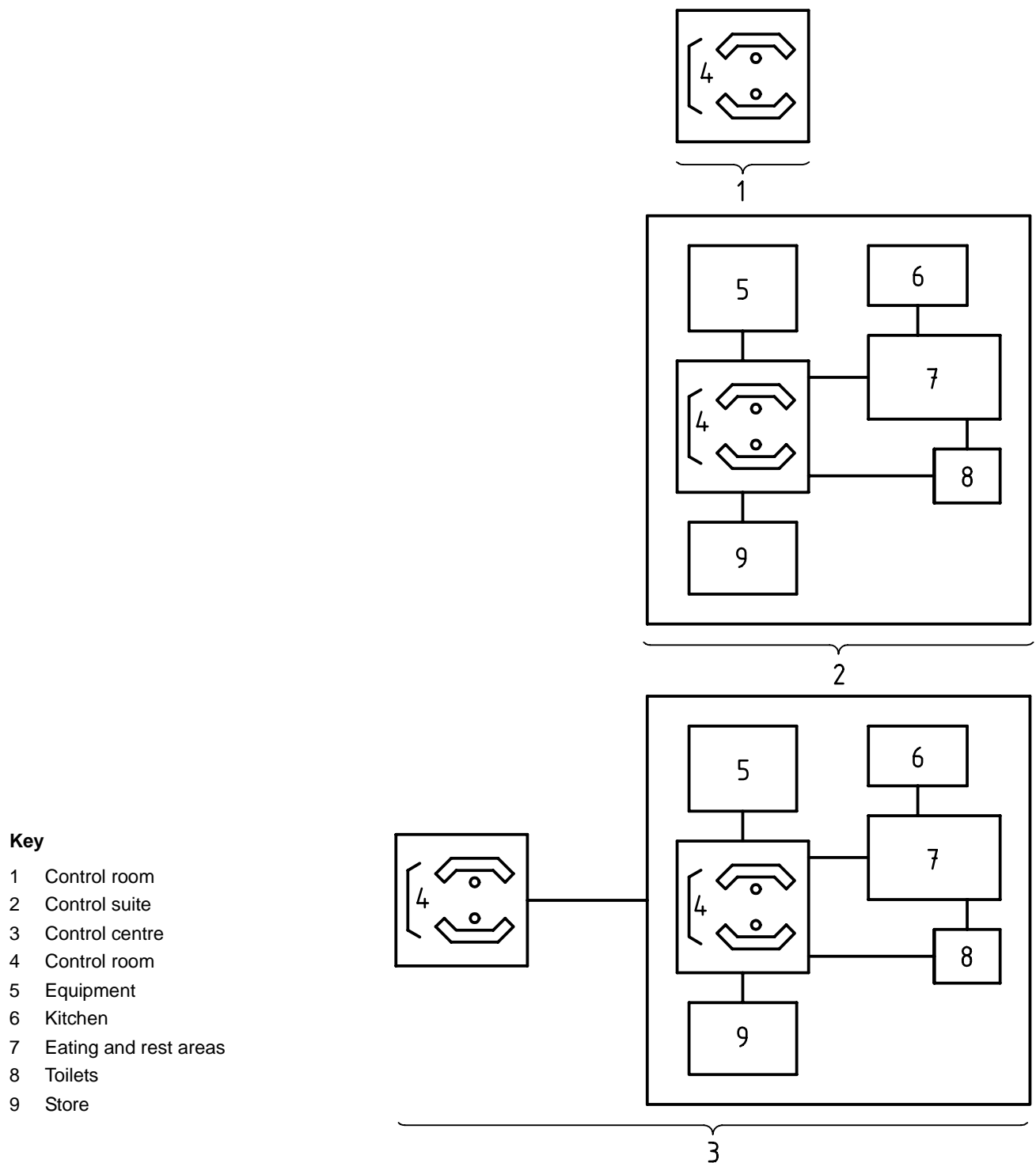

Figure 1 — Schematic illustrations of control room, control suite and control centre

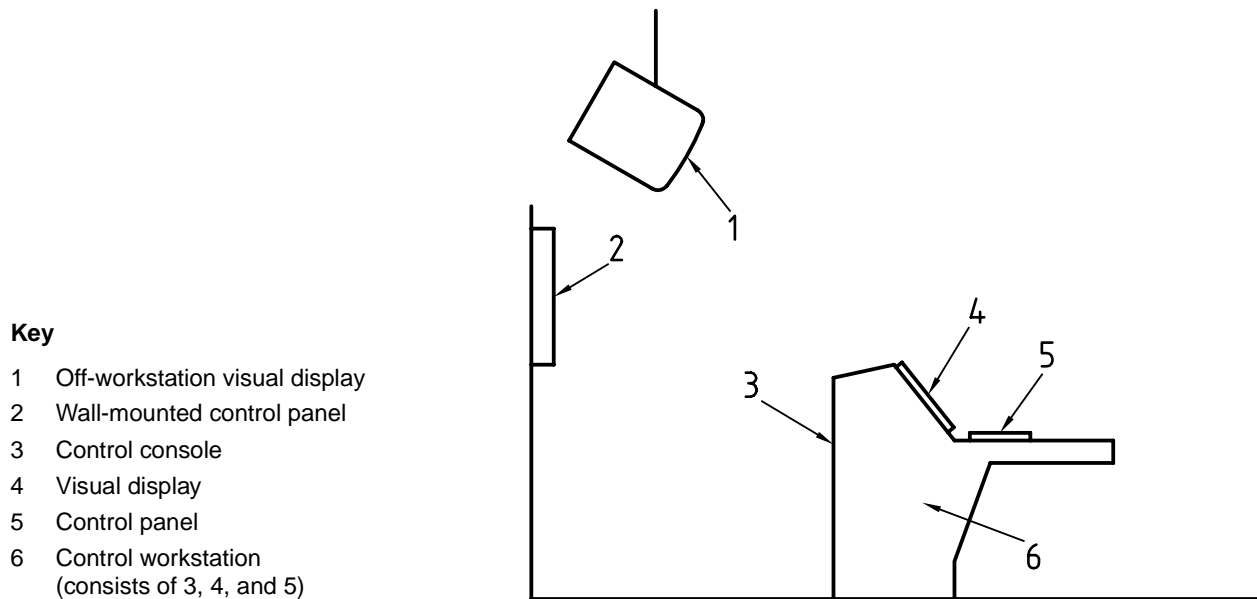

Figure 2 — Illustration of definitions associated with control workstation and off-workstation visual displays

4 Ergonomic design of control centres

4.1 Process for control room layout

The following flowchart summarizes a general procedure for the control room layout, where only the main activities have been noted (see Figure 3).

For the purposes of this part of ISO 11064, it is assumed that a number of control room characteristics have been largely finalized and act as an input to the process summarized in the flowchart. These ergonomic features include job descriptions, staffing profiles, equipment specifications and overall operating procedures. For many control room projects, at the stage where layouts need to be undertaken, not all of the ergonomic features have been finalized. In order to proceed with the ergonomic design process in accordance with this part of ISO 11064, it is necessary to agree upon working assumptions for those aspects where final information is not available. This information and the finalized ergonomic features are recorded in an Operational Specification or Functional Specification.

The flowchart refers to information input during the preparation of “functional layouts”. This information will include the number of control workstations as well as any required arrangements of workstations. Grouping should be based on functional linkages, for example, equipment sharing, direct lines of sight and requirements for direct speech.

The development of a preferred control room layout will, typically, include the following activities. Based on the operational requirements summarized in a functional link analysis, workstation arrangement and layouts should be prepared within the available space. These layouts should take account of such functional links, as face to face communications and sightlines to shared off-workstation overview displays, as noted in the functional link analysis. Functional layout need only be approximately to scale. A number of different functional layout options are prepared which meet, to varying degrees, the requirements in the Operational Specification. Translating these functional layouts to possible room layouts is achieved by replacing functional groups with approximate workstation footprint sizes and adjusting the layouts to maintain required circulation and maintenance access. A similar process can be used for room layouts where no space has been decided for the control room, under which circumstances the functional layouts/room layouts can be used to specify the space to be provided for these functions.

Once having determined alternative control room layouts, these shall be tested by control room operators/users against the requirements contained within the Operational Specification. Through a process of iteration, the best control room layout should be sought.

The final control room layout selected should be validated against documented performance criteria, and a record made of the performance of the room against these criteria and any compromises made (see 4.2.6).

4.2 General considerations for control room layout

This subclause summarizes some general considerations for the planning and layout of control rooms. A fuller account of these is presented later in this part of ISO 11064 together with other requirements concerned with control room layout.

4.2.1 Architectural considerations

4.2.1.1 Entrances/exits

Main entrances and exits should not form part of the working visual fields of the control room operator, unless the operators have some specific responsibility for checking on the entry/exit of staff (see 4.4.1).

Entrances and exits should not be positioned behind the control room operator (see 4.3.3).

4.2.1.2 Personnel safety

Features, such as guard-rails and handrails, should be provided to minimize safety hazards in control rooms (see 4.3.2) where various floor levels are found.

4.2.1.3 Future expansion

Control rooms should allow for expansion: provision for expansion will be influenced by such factors as the built-in life-span of the control room and predicted changes in workload or logistics: typically allowance for approximately 25 % increase in working positions and equipment has been found from practical experience to be prudent (see 4.3.2).

4.2.2 Operational considerations

4.2.2.1 Task analysis

Room layouts should be based on an agreed set of principles derived from operational feedback (if available), task analysis and an understanding of the worker population including workers with disabilities: these underlying principles should be fully documented (see 4.1).

4.2.2.2 Team working

The layout of control rooms, where many of the control room operators work, should facilitate team working opportunities and social interaction for operators where this factor is deemed important for the primary tasks to be performed (see 4.4.1).

4.2.2.3 Organizational factors

The control room layout should reflect the allocation of responsibilities and the requirements for supervision.

4.2.2.4 Operational links

Optimizing key operational links, including sightlines, or direct speech communication should be a goal in control room layouts (see 4.4.1).

4.2.3 Workstation arrangements

4.2.3.1 Room layout

Control rooms which exhibit either overcrowding of workpositions, or widely dispersed workpositions, are not recommended. Layouts should allow, wherever practical, direct verbal communication between the control room operators and avoid excessively short separations between adjacent operators (see 4.4.1).

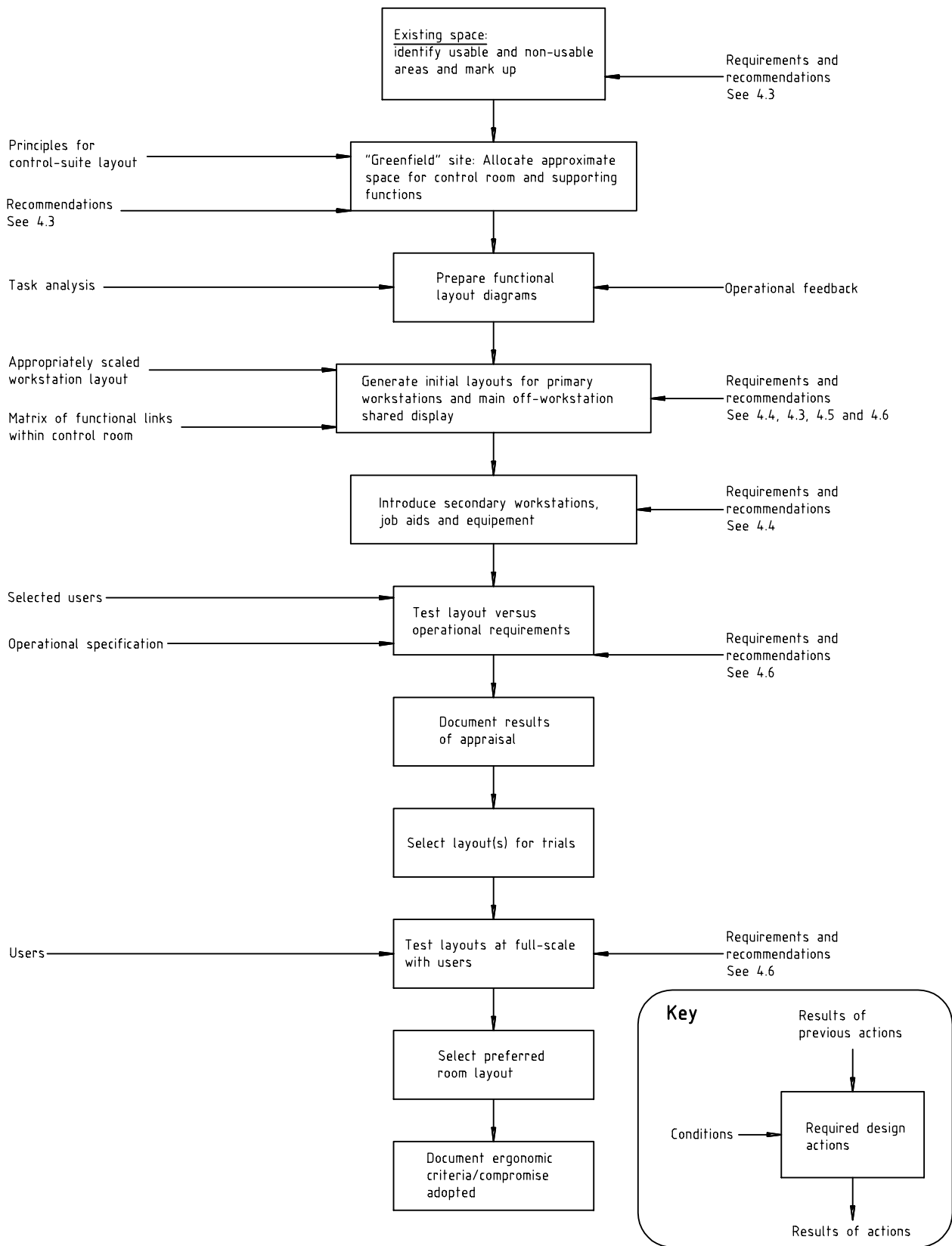

NOTE Feedback loops can occur at any stage of the process.

Figure 3 — General procedure for control room layout

4.2.3.2 Consistency

Control rooms with similar functions and in the same plant or facility, such as occur in a control complex, should adopt the same ergonomic principles of room layout to facilitate decision-making and teamwork.

4.2.3.3 Physically disadvantaged

Where physically disadvantaged control room operators or visitors (those exhibiting a disability) are expected to use the control room, adequate facilities should be provided (see 4.4.5).

NOTE National regulations may take precedence over the requirements in this part of ISO 11064.

4.2.3.4 Posture variation

There are ergonomic benefits in varying postures during periods of work. Wherever practicable, it is recommended that control workstation layouts and work regimes allow control room operators to change their posture at the control workstation and to move from their workstations from time to time (see ISO 9241-5:1998). Under no circumstances should this interfere with primary control duties or be undertaken as part of a time-critical activity.

NOTE This may be achieved by locating some off-workstation equipment at a distance from the main operating positions.

4.2.3.5 Body size

Room dimensions and control workstation layout dimensions and features for which peoples' sizes are relevant, e.g. seated view over workstations, shall take account of the range of control room operators for which these items are being provided (see 4.5.1).

4.2.3.6 Windows

Control room operators using visual displays should not be facing windows unless these windows are a primary information source. The location of control workstations where windows are behind the operator should be avoided since this may give rise to reflections on the display screen. If control room operators do have to face windows, whilst using visual display terminals, the differences in luminances should not lead to glare. See clause A.4.

4.2.4 Off-workstation shared visual displays

The layout of the control room shall ensure that all off-workstation visual displays, necessary for the control room operators' task, are visible from all relevant control workstations (see 4.5.1).

4.2.5 Circulation of personnel and maintenance access

Circulation of control room staff, maintenance staff and all visitors should be achieved with minimum disruption to the work of control room operators (see 4.6.1).

Where it is anticipated that the supervisory positions will give rise to additional circulation from outside the control room, it is recommended that these positions be located close to main entrances (see 4.6.1).

Operational areas should have a means of restricting thoroughfare access (see 4.6.1).

All aspects of control room layout shall take account of the requirements for maintenance access (see 4.6.2).

4.2.6 Verification and validation of control room layout

Verification is the process of determining that something has been designed and constructed according to a defined specification. Validation is the process of determining that the object, which has been built/developed, is able to carry out the task for which it is intended.

Verification and validation should be integrated with the design process and should be performed in parallel with top level design, detailed design and during the development of prototypes. Verification and validation should be an iterative process during the development of the design. It should give feedback to the designer in moving towards the best possible solution. It may include a number of different methods and techniques.

Examples of these are

- guideline evaluations (or use of checklists), i.e., using human factor guidelines and standards to check the design;

- different task analysis techniques like link analysis or time-line analysis, where communication and co-ordination can be tested;
- the use of “walk and talk through” techniques, where the idea is to work through scenarios/sequences in the new design.

These techniques need appropriate representations of the new design which could be

- representations based on drawings and photographs,
- traditional full-scale mock-ups or small models, or
- computer models, as produced by computer-aided design tools.

Finally, as an advanced tool, mock-ups based on virtual reality technology could also be used.

4.2.7 Documentation

Evaluation criteria, compromises and decisions based on ergonomic principles should be documented and securely stored so that future modifications can take proper account of these factors (see Figure 3).

4.3 Architectural/building recommendations

The recommendations in this subclause relate to the provision of space within buildings for control rooms.

4.3.1 Plan space provision

4.3.1.1 Selection of space

In particular the following factors have to be taken into account.

- The selection of a space for a control room should be based on the usable area, not the gross area.
- Obstructions and structural features, such as pillars and awkward corners, within a proposed/planned control area, will severely reduce the available space and could result in sub-optimal work layouts.
- A heuristic value for planning floor-space allocation is to allow for 9 m² to 15 m² per working position with a minimum of not less than 9 m². This has been found to be satisfactory for rooms with more than one control room operator and which are permanently staffed, and takes account of typical equipment volumes, seating space and maintenance access. Precise requirements shall be based on a task analysis. This space provision is based on the use of “usable” area.

NOTE 1 The figures presented are based on a survey of spaces actually used in operational rooms which were themselves based on an ergonomic design process. These figures, of 9 m² to 15 m² per working position, are typically associated with control rooms comprising single workstations (or clusters of workstations) and no large, off-workstation shared visual display. In some control rooms, where large, shared overview displays are a dominant operational feature, space allocations of up to 50 m² have been measured.

- If additional staff need to be accommodated during off-normal operations, within the control room, sufficient space should be allowed for these additional staff to be housed.
- Temporary positions should be provided alongside permanent control room operator positions, where these additional staff are expected to be present during shift changes.
- Square, circular and hexagonal spaces are preferred for the arrangement of functional groups, because they offer the potential of maximizing the number of links (see Figure 4); long narrow spaces should be avoided since they can unduly reduce options.

NOTE 2 It is recognized that certain shapes of room are more likely to concentrate noise, which can sometimes lead to problems: such room shapes include hexagonal and circular configurations. Curved walls are sometimes restrictive as far as future control workstation rearrangement is concerned.

4.3.1.2 Future expansion

In particular, the following has to be taken into account.

- Space provision should consider requirements over the full planned life-span of the control room and account should be taken of future increases in workloads, staffing and equipment. Where planned, life-spans can be in the order of 10 years to 20 years; it is prudent to allow for up to 25 % additional space to allow for such expansion.

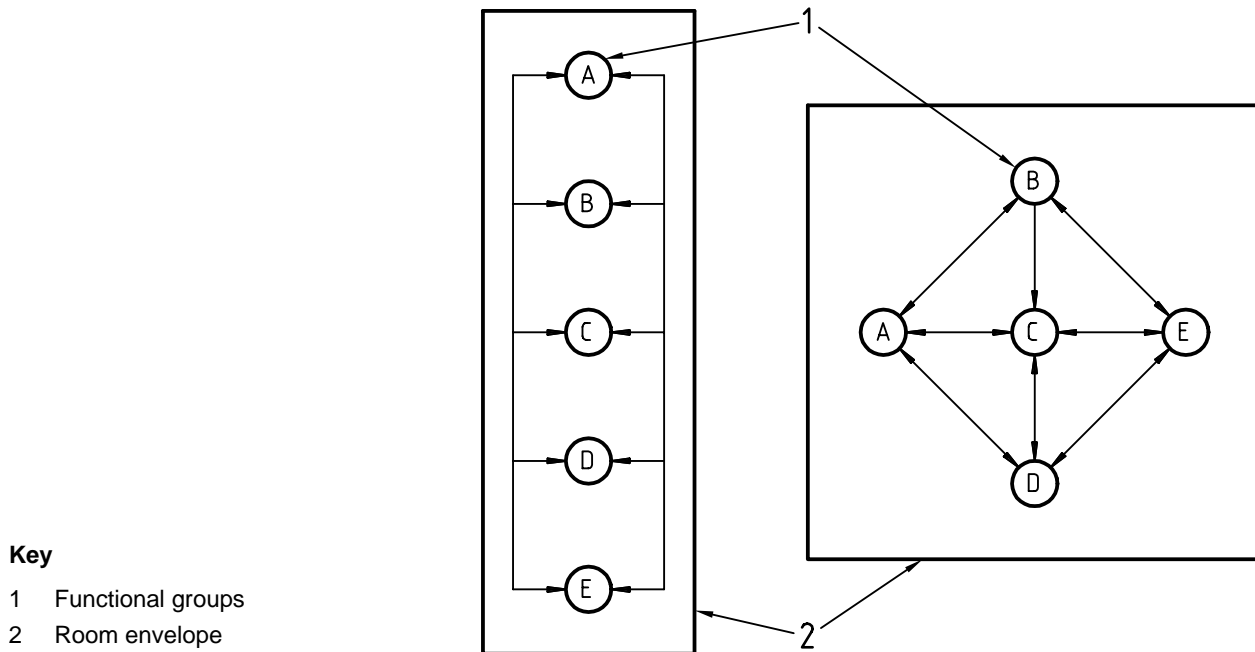

Figure 4 — Room shape and functional layouts

4.3.2 Vertical space provision

In particular the following has to be taken into account.

- Control rooms with a single finished floor height offer greater flexibility for future change and for the movement of equipment and personnel, especially those with disabilities.
- For a given control area, single height ceilings are preferred.
- As a “rule of thumb”, slab-to-slab heights should preferably be a minimum of 4 m, to include false floors, false ceilings, indirect lighting systems and the accommodation of shared off-workstation visual displays. In practice, such a design would result in finished floor to finished ceiling heights of at least 3 m.

NOTE In Figure 5 the dimensions are based on a P99 male for illustrative purposes. The appropriate user population data should be used.

- Uncluttered ceilings are preferred to avoid any distractions or stray reflections from luminaires; such plain finishes are also recommended for walls and any structural elements.
- Differing finished floor heights can sometimes offer advantages for viewing areas, supervisory overviews and a means of keeping “public area” segregated. To avoid various safety hazards, including trip hazards, ramps should be considered for movement of equipment and personnel.
- The viewing of shared off-workstation visual displays, by groups of control room operators, can sometimes be improved through the introduction of multi-level floor heights.

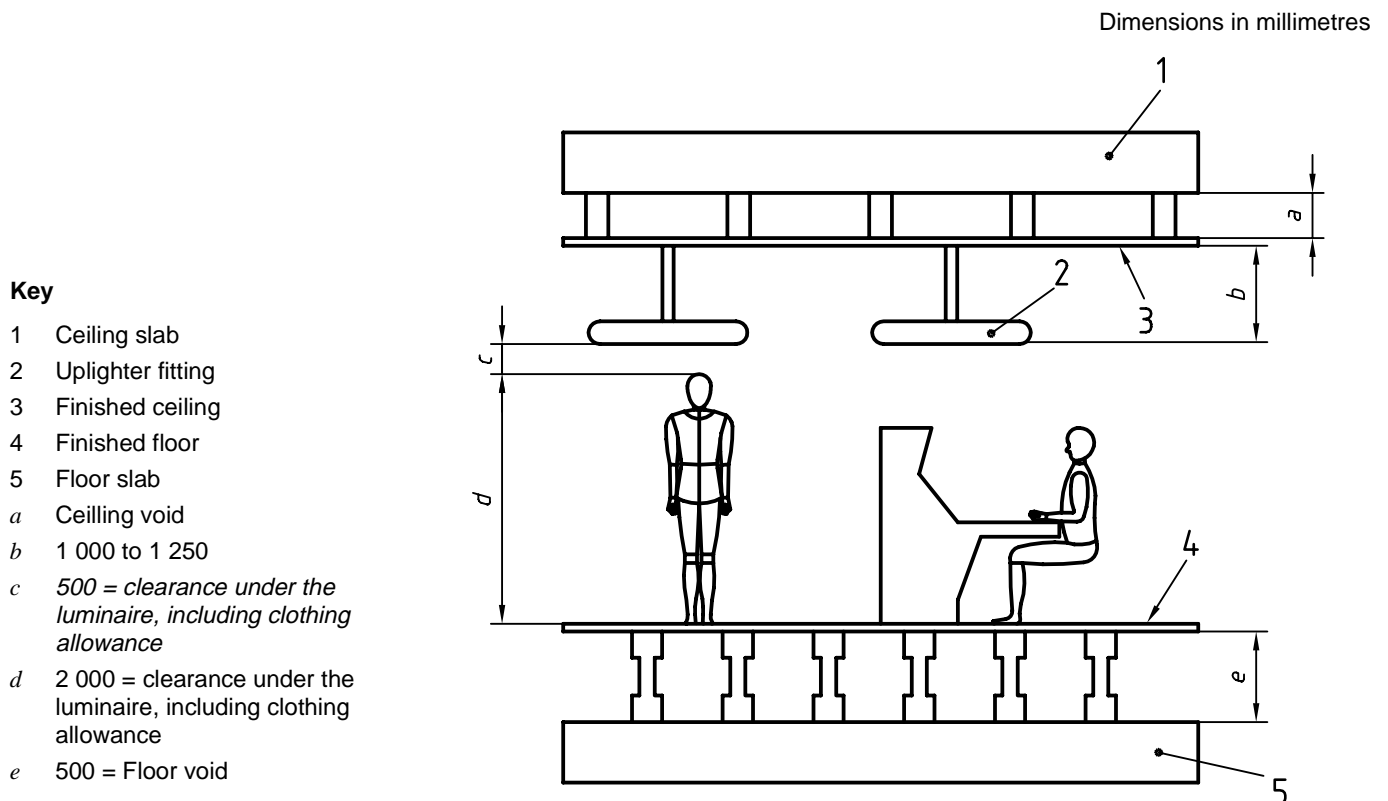

NOTE The dimensions are given as an example.

Figure 5 — Vertical space provision

4.3.3 Exits, entrances and walkways

In particular, the following has to be taken into account.

- The location and number of the exits and entrances should take account of such factors as the number of control room operators and the functional links to areas outside the control room.
- A single main entrance and exit offers the best solution for security and staff control. However, other emergency exits may need to be provided.
- Entrance location should be considered in relation to supporting functions situated around the control room, such as toilets, relaxation areas, supervisors, offices.
- The sizes of entrances/exits should allow for the passage of trolleys, and accommodate control room operators and visitors with disabilities, movement of equipment and the introduction of any other maintenance equipment which can sometimes be required to be used in the control room. Entrances that are sized for equipment passage are usually adequate for persons using wheelchairs.
- Where access into the control room is required for, say, the collection of “permits to work”, keys or documents, adequate account should be taken of circulation routes and temporary waiting areas.
- Where counters are used for the receipt or collection of documents, such as “permits to work”, these often need to be near entrances or easily accessible from certain operating positions.
- Where changes of floor level are introduced in conjunction with entrances or exits, proper physical “aids” should be provided (such as guard rails, handrails, anti-slip surfaces) to minimize potential hazards.

NOTE National regulations may take precedence over the requirements in this part of ISO 11064.

4.3.4 Windows

Windows are provided in control rooms for operational, psychological and physiological reasons, not necessarily for illumination. Large luminance differences between the visual displays, used at a workstation, and areas around them, shall be avoided. The ratio of luminances for task areas that are frequently viewed in sequence (e.g. screen, document and windows) should be lower than 10:1. Within a static visual field a significantly higher ratio of luminances can be tolerated between the task area and its surrounds (e.g. display housing and walls) and should not have any adverse effect. However, a luminance ratio of 100:1 between two areas would be expected to produce a small but significant drop in performance (see ISO 9241-3).

A glare-free usage of displays shall be guaranteed.

The provision of windows often gives rise to conflicting demands sometimes leading to the exclusion of windows from the control room (i.e. for security or safety reasons). The control room operator's task can include direct visual information from outside the control room, thus requiring windows within the operator's visual field. The following situations are discussed within this subclause:

- windows are a given fact in the (existing) control room;
- windows are not needed for information purposes;
- windows are needed for information purposes;
- windows can be introduced after the control room layout has been established.

When windows are included in control rooms, the following shall be taken into account:

- workstations shall not be facing windows unless they are a primary information source;
- windows shall not be located behind the operator in order to avoid glare or disturbing reflections on displays;
- windows shall have user-operable blinds;
- windows, which are located on the left and/or right side of the workstation, shall have a minimum distance of 3 m to the workstation,
- for those cases where operational information is obtained via windows, the nature of this information shall be established;
- windows shall be included in meeting and relaxation areas and offer an alternative visual environment to that in the control room;
- primary control workstations shall be shielded from windows present in non-operational areas of the control suite;
- window size shall allow the control room user to get a glimpse of the environment; a light neutral tint is acceptable to reduce sky brightness, but dark tints can make the outside world look too gloomy.

4.3.5 Visitors

In particular the following has to be taken into account.

- Visitors should not be able to see "informal activities" undertaken by control room operators, such as reading and taking refreshments which sometimes occur during quiet periods. This may be achieved by minimizing unobstructed sight of the control workstation worksurfaces from all areas where visitors are likely to have access.
- The design of facilities for visitors should be taken into consideration from the beginning of the project and treated as a normal function to be accommodated by the control suite.
- Where confidential information is presented, it should not be possible to see this from the public viewing areas.
- Public viewing areas should be designed so that control room operators do not feel that they are there for "entertainment" of the visitors.
- When raised viewing galleries are to be included in the control room, the impact these might have on natural and artificial lighting in the control room should be considered.

4.4 Workstation arrangements

The requirements and recommendations presented in this subclause concern the horizontal and vertical arrangements of control workstations within the control room.

4.4.1 Plan arrangements

In particular the following has to be taken into account:

- Operational links between control room operators, such as speech, sightlines or direct voice communication, should be documented, by using link association tables prior to developing control workstation layouts, and should provide a benchmark against which alternative layouts can be assessed (see Figure 3). In these tables, primary and secondary operational means are spelt out, including direct visual, message passing or equipment sharing requirements.
- When considering alternative ways of laying out a number of control workstations the following factors should be taken into consideration:
 - a) whether control workstations are dedicated to individual operators or are shared;
 - b) whether each control workstation is identical;
 - c) whether all operations can be carried out from a single control workstation or tasks are spread amongst a number.

NOTE Where clusters of control workstations are grouped together to form a single unit, the way in which operators are arranged around the workstation can offer different advantages (see annex A).

- Where a number of control rooms, operating on the same system, are located on various sites or countries, they should adopt similar layouts. Adopting this approach facilitates the transfer of control personnel from one site to another and can reduce training time and errors.
- Control workstation arrangements shall take into account operations under normal and abnormal modes of system operation; for example, fall-back arrangements for information transmission by paper or other non-electronic means.
- Where ventilation systems, light fittings and windows have already been installed, positioning of control workstations should take account of these to avoid draughts, glare and reflections on visual display screens.
- Social contact within the control room should be allowed for by grouping operators so that informal conversations (those which have nothing to do with the operation of the control room) can occur between individuals without compromising operator efficiency. In larger control rooms, particular care should be taken that such informal links can be maintained when staffing levels are reduced during quieter periods.
- Control workstation layouts should provide an operationally satisfactory working environment under both maximum and minimum staffing levels.
- Control workstation layouts should provide for the convenient storage and display of all necessary reference documentation which control room operators require to access as part of their duties as well as items which can be required in emergencies.
- Special consideration should be given to the requirements of the standing control room operator for appropriate reference storage, display and use.
- Where control workstations are grouped together, the minimum distances between adjacent positions should not result in individuals sitting within each other's "intimate zones". Whilst occasional close working may be acceptable, working positions adopted for extended periods should avoid control room operators having to intrude within each other's intimate zones.
- Spacing between control room operators should take account of shared equipment, where consideration of common reach zones or potential problems of interference due to noise need to be applied.
- Approximate control workstation sizing for initial room layout purposes should take account of such factors as equipment sizes, flat worktop provision and the requirements for on-workstation storage and accommodation for workers with disabilities: any such layouts should be fully checked through workstation and room trials prior to being finalized.

- When selecting room layouts, attention should be paid to training requirements for control room operators, for example, additional space for equipment adjacent to a normal operator's position or a separate, discrete training workstation.
- Layouts should take account of maintenance requirements and access space for technicians and equipment removal, particularly where this involves bulky items.
- The general arrangement of control workstations should be such that flow from general circulation areas is inhibited. However, the use of actual physical barriers to do this is not advocated.
- Control workstations should be positioned such that views of entrances and exits are minimized, to reduce visual distraction, from the normal operating position unless operational requirements demand this.

4.4.2 Supervisory control workstations

In some control rooms, certain control workstations are designated as supervisory and some of the following additional requirements can be associated with their location in the control room.

- Supervisory control workstations should take full account of the additional reference material which is sometimes required to be stored, displayed and used at these positions.
- In arranging supervisory control workstation layouts, an early decision needs to be taken as to whether the primary duties of the supervisors are to supervise the systems, the control room operators or both. For system monitoring, layouts will place greater priority on equipment positioning; whereas for direct operator supervision, workstation positioning in the room and workstation profiles are more important.
- Layouts should allow for additional circulation around supervisory positions and for the temporary accommodation of visitors.
- Where major incidents are handled from the supervisory area, the provision of extra vertical display surfaces needs to be considered for the presentation of maps, charts or procedures. Consideration should also be given to the additional space required by extra staff who sometimes need to be accommodated in this area. Where such major incident facilities are not immediately within the supervisory workstation area, the size and location should be considered during control-suite layout.
- Where major incidents are **not** handled in the supervisory area in the control room, provisions for a separate major incident area need to be considered in the control-suite layout.

4.4.3 Vertical arrangements

The use of varying floor levels in a control room can offer some advantages in viewing shared overview visual displays and improving sightlines between control room operators. These benefits can also be achieved by other means, such as the careful layout of the control room or the duplication of overview equipment. When considering adopting a solution based on varying floor levels in a control room, the following are some of the drawbacks which should be taken into account:

- can restrict direct visual, verbal and social links;
- can create obstacles to the movement of people;
- movement of larger items of equipment can be restricted;
- future changes in room layout can be more difficult and flexibility can be reduced;
- variation in control workstation heights, and location of control room operator, can require particular attention to be paid to lighting and heating control;
- wheelchair access will need to be provided by ramps, which will require additional floorspace, or wheelchair lifts.

4.4.4 Secondary workstations

Where it is impractical to store all equipment or reference material at the control workstation (or a position included which can deal with an overflow of tasks during peak workloads), the provision of a secondary workstation should be considered. The layout and design of any such workstations should adhere to the same ergonomic principles as laid out for primary positions and their layout based on a task analysis.

4.4.5 Additional considerations on workstation layout

In particular, the following has to be taken into account.

- The layout of control workstations should take account of future requirements. Control room workstation layout should take account of the initial operation as well as the requirements likely to be in place at the end of the planned life span. Such considerations should include the most likely upgrades in terms of equipment, additional working positions and changes in operational procedures.
- The needs of those with disabilities should be considered during the layout of the control room by, for example, allowing additional circulation spaces and introducing ramps for wheelchair access (see clause A.5).

NOTE National regulations may take precedence over the requirements in this part of ISO 11064.

- Hard-copy information storage should be classified such that the most appropriate provisions can be made within the control room. An appropriate classification is suggested in Table 1.
- Adequate provision should be made for the storage of items of a personal nature, both in the control room, at the control workstation (briefcases, purses) or outside the control area in locker rooms (for clothing etc.).
- The requirements of secondary users, such as field operators and auxiliary operators, who sometimes need to work in the control room on a temporary basis should be considered. This can sometimes involve the provision of suitable worktops to lay out paperwork, appropriate seating and accommodation for coats and helmets. All such requirements should be fully determined by the conduct of an appropriate task analysis.

Table 1 — Control room storage — Classification of types

Storage requirement	Typical location	Example
Immediate access	Primary control workstation	Operational procedures High-priority telephone numbers Emergency procedures Diagnostics Large charts and tables
Secondary access	Secondary control workstation Adjacent workstation	Internal telephone directory Secondary operating procedures Architectural/engineering drawings
Occasional access	Library	Non-critical equipment failure procedures

4.5 Shared visual displays, off-workstation

The requirements presented in this subclause concern the location of shared visual displays within the control room. Many differing technologies can be used for overview visual displays, including banks of closed circuit television (CCTV) monitors, projected displays, hard-wired mimics and static maps/diagrams. When designing control room layouts for these differing solutions, the constraints imposed by the various solutions will need to be considered. Such constraints include limitations on viewing angle, contrast ratios and image construction.

As an alternative to large shared displays, the option of presenting this information on the control workstation, with smaller schematics, should be considered.

4.5.1 Horizontal and vertical viewing distances

In particular, the following has to be taken into account.

- Where off-workstation visual displays need to be used on a regular or continuous basis, the preferred position is directly in front of the control room operator such that they can easily be seen when looking over the control workstation or can be scanned by eye-movement alone (see ISO 11428 and Figure 6).

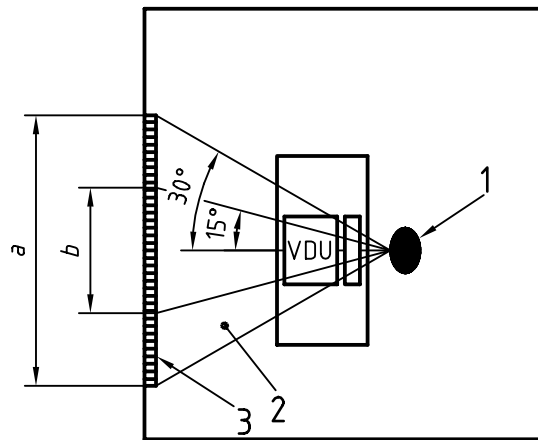

Key

- 1 Operator
- 2 Horizontal visual field
- 3 Off-workstation visual display

NOTE This plan view is intended to show general principles.

Figure 6 — Preferred location of off-workstation visual displays

- Where the information presented on an off-workstation shared visual display does not have to be read whilst operating the console, or provides secondary information, the displays can sometimes be mounted to one side of the control workstation. Such displays should be positioned so that all information required can be reliably read, from the control room operator's normal position, by a simple rotation of the control chair.
- For very large off-workstation visual displays, which need to be monitored on a continual or regular basis, it is recommended that control room operators be allocated sections of the common display which they can effectively and conveniently monitor.
- Where the information on an off-workstation overview visual display needs to be regularly used by control room operators, the design of the visual display and the layout of the control room should ensure that all of the information which needs to be used by a control room operator can be seen from the normal working position for both the vertical and horizontal planes.
- Necessary information presented on shared overview visual displays shall be visible by personnel, with applicable 5th to 95th percentile body dimensions of the user population, from their normal working positions (see annex B). There can be a requirement for safety critical information to be seen. Under these circumstances, the user percentile range to be accommodated may need to be greater.
- Operational information presented on the lowest part of an off-workstation visual display shall be visible to a 5th percentile, seated, non-upright control room operator. The following formula may be used to determine this measurement:

$$H_1 = H_c - (D + d) \frac{H_e - H_c}{D_c + d} \tag{1}$$

where

H_1 is the lowest height at which the visual display can be seen;

H_e is the design-eye-position, measured from the floor to the outer corner of the eye; 5th percentile shall be applied;

NOTE H_e is a combination of the adjusted seat height and the anthropometric data of "eye height, sitting" (see annex B).

H_c is the height of the console;

D is the horizontal distance between the front edge of the console and the surface of the wall panel;

D_c is the depth of the console;

d horizontal distance between the design-eye-position and the front edge of the console.

For an explanation of the dimensions, see Figure 7.

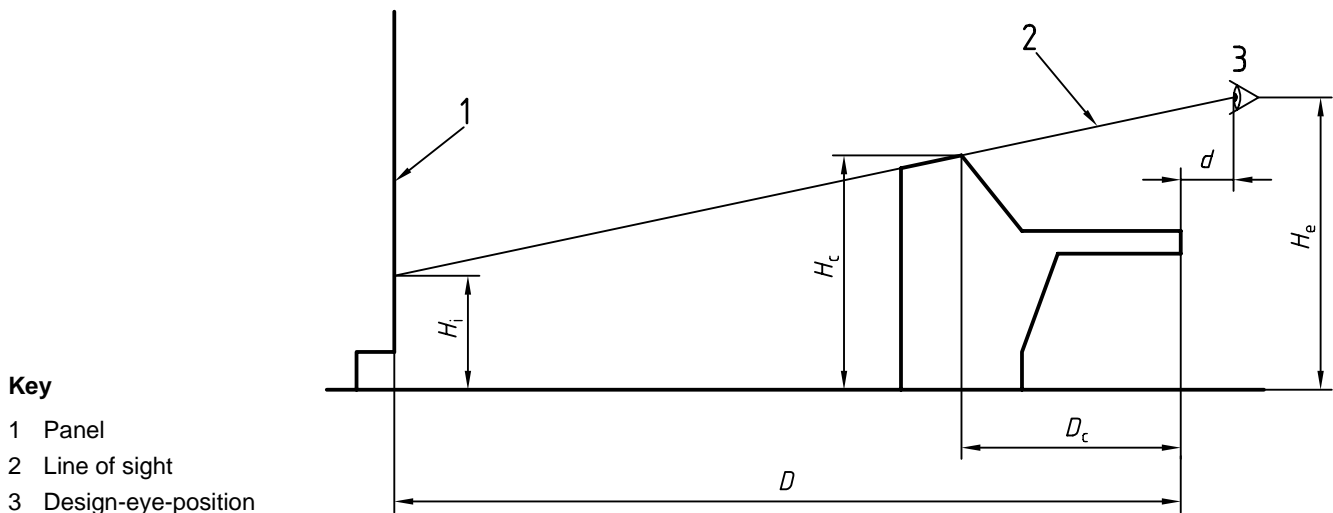

Figure 7 — Control workstation height and view over

NOTE The appropriate data for the expected user population should be applied; sample anthropometric data are presented in annex B.

4.5.2 Relationship of shared visual displays to other features

In particular, the following has to be taken into account:

- Windows should not be located adjacent to off-workstation visual displays or within the same field of view.
- Artificial room lighting should not interfere with the visibility of any sections of the off-workstation, shared visual displays.
- Finishes around off-workstation, shared visual displays should be carefully controlled so as not to interfere with the visibility of parts of the shared visual display.
- Entrances and exits should not be located within the same field of view as major off-workstation visual displays.

4.6 Personnel circulation and maintenance access

The requirements and recommendations presented in this subclause concern the provision of appropriate space for general circulation, maintenance and cleaning.

4.6.1 Personnel circulation

In particular, the following has to be taken into account.

- Adequate provision should be made for the general circulation, such that control operations are not interrupted by either visual or auditory distraction.
- Particular care should be taken to provide adequate circulation areas where shift changeover is protracted and two shifts are present at the same time.
- The layout of the control room shall allow for the orderly evacuation of the room.
- Control room circulation routes should be arranged to avoid cross-circulation.
- Restricted ceiling heights should be indicated: the use of ceiling-mounted warning signs can be considered for these purposes.

- The following formula should be used for the minimum dimensions of circulation spaces where a single individual needs to pass with forward movement and in an upright posture (see Figure 8). Additional space should be allowed if tool boxes or other items are to be carried.

For non-emergency exits:

$$A = h(P95) + x \quad (2)$$

$$B = a(P95) + y \quad (3)$$

For emergency exits:

$$A_{em} = h(P99) + x \quad (4)$$

$$B_{em} = a(P99) + y \quad (5)$$

where

A is the opening height;

A_{em} is the opening height for emergency exits;

B is the opening width;

B_{em} is the opening width for emergency exits;

h is the stature (body height);

a is the elbow-to-elbow breadth;

x is the height allowance (to allow adequate clearances for such items as helmets, caps and shoe height);

y is the width allowance (to allow adequate clearances for bulky clothing);

P is the percentile;

$P95$ is the 95th percentile of the expected user population;

$P99$ is the 99th percentile of the expected user population.

Concerning the definitions of human body measurements, see ISO 7250.

NOTE Furthermore, National Regulations may take precedence over the requirements in this part of ISO 11064.

- Emergency exits shall use the appropriate P99 value whereas those for non-emergency may use the appropriate P95 value; these values to be derived for the user population. The distinction between the P95 and the P99 value can become blurred when clearances take account of the dynamics of walking movement.
- The space provision for two-person circulation should be based on Formulae 2 to 5 presented above and doubled with the appropriate allowances made for tool boxes or other items being carried.
- Fixed items should be placed far enough from the swept area of hinged doors in order to avoid pinch points. The possibility of individuals being overcome by fire, smoke or gas should be considered in the design of door swings such that the likelihood of an unconscious individual obstructing the door is eliminated.
- For wheelchair users, allowances need to be made for the maximum width of the largest wheelchair and clearances for elbows to propel the chair (see Figure 9).
- Wheelchair users will require additional space for turning and these should be provided at appropriate locations in the control room. Clause A provides some guideline dimensions.

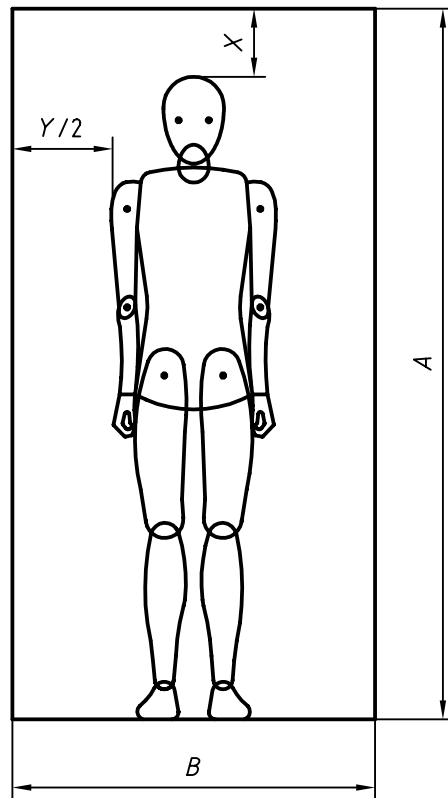
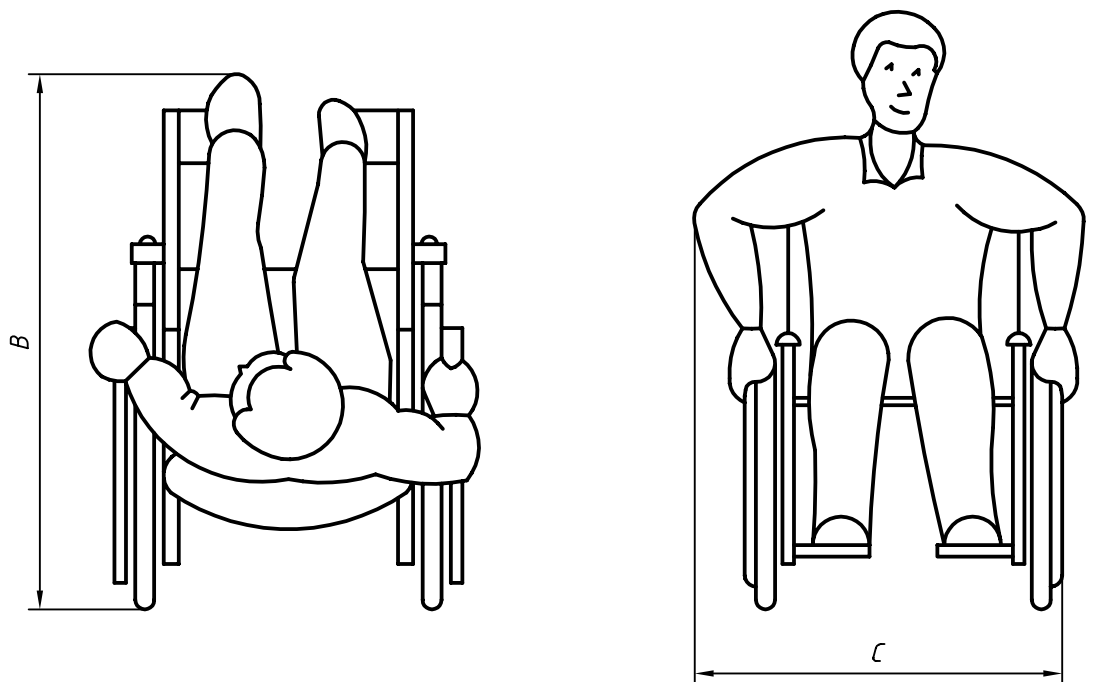

Figure 8 — Minimum circulation space for personnel



Key

- B* Full length of wheelchair
- C* Width of wheelchair and elbow clearance

NOTE See clause A.5 for dimensions concerning wheelchair users.

Figure 9 — Wheelchair clearance

4.6.2 Maintenance access

In particular the following has to be taken into account.

- Space shall be allowed for maintenance such that inadvertent activation of equipment or systems is avoided.
- Experience shows that items of equipment housed on mimic panels should be mounted at least 700 mm above the finished floor height for reasons of visibility and access for maintenance.
- Rear access to control workstations is recommended, since it allows control staff to continue their operations. Adequate clearance behind the control workstation should be allowed for a kneeling maintenance engineer to work. Some suggested space provisions based on world populations are presented as guidelines in Figure 10.
- Off-workstation panels and displays sometimes require maintenance access to the rear. For such units, adequate space shall be allowed for the larger maintenance technician from the user population, 95th percentile (see annex B) and consideration given to the use of ladders and carrying of tool boxes.
- Where heavy or bulky items of equipment need to be removed, the appropriate manual handling guidelines should be consulted. It is sometimes necessary to provide mechanical assistance or hoist points.

Access to service ducts and serviced equipment should, wherever practical, be from outside the control room.

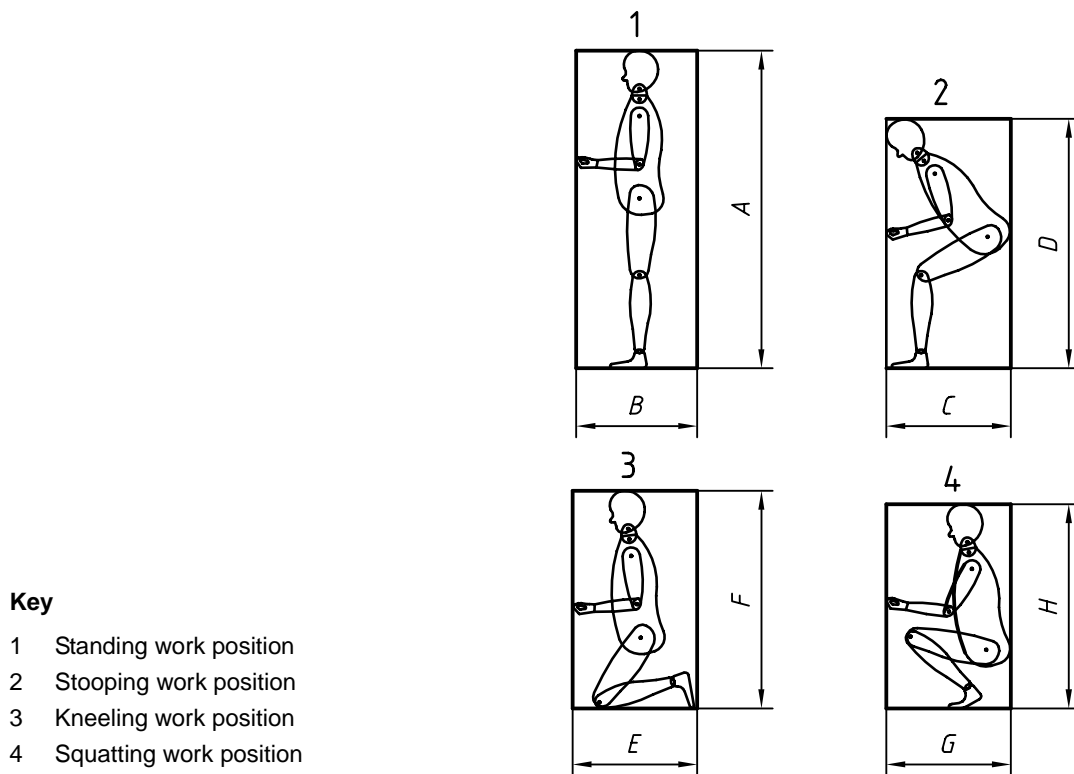

See Table 2 and annex B for further details on dimensions.

Figure 10 — Minimum space requirements for maintenance of control panels

Table 2 — Minimum space requirements and allowances that need to be taken into consideration

Dimension ^a	Minimum space requirements mm	Allowances to be taken into consideration
A	1 910	for largest maintenance technician p95 ^b
	30	for shoes
B	700	for largest maintenance technician P95
C	760	for largest maintenance technician P95
D	1 500	for largest maintenance technician P95
E	760	for largest maintenance technician P95
F	1 370	for largest maintenance technician P95
	30	for shoes
G	760	for largest maintenance technician P95
H	1 220	for largest maintenance technician P95
^a These dimensions relate to alternative postures adopted for maintenance and are illustrated in Figure 10.		
^b P95: 95th percentile of the expected user population.		
NOTE The table above covers the whole world population. Where available, equivalent user population data should be used.		

4.6.3 Cleaning

In particular the following has to be taken into account.

- Inadvertent activation of any safety-critical controls shall not be possible during cleaning.
- An adequate number of power outlets should be provided which will enable cleaning appliances to be used, and maintenance to be undertaken, without causing electrical interference or disturbing control room operations.
- Where gaps occur between items of equipment or furniture, adequate clearances should be allowed for cleaning to be undertaken.
- It should be possible for all necessary cleaning to be undertaken without interruption to control room activities.
- Special provision is sometimes required where food and other refreshments are permitted to be consumed in the control room.
- The control room layout should not give rise to unsuitable working postures or working movements for cleaning staff.

Annex A (informative)





Examples of control room layout

A.1 General

The tables and associated figures presented in this annex illustrate different ways in which workstations can be arranged. Some of the factors considered include views to shared off-workstation visual displays, operational links between control room operators' and contact between supervisors and operators. The diagrams are intended to highlight some of the advantages and disadvantages of alternative groupings of control workstations; they are not intended to be exhaustive or prescriptive.

The tables, associated with the figures, summarize the likely performance of these layouts against a number of operational features. The tables illustrate the wide range of alternative workstation arrangements which can be possible. The most suitable form of layout should be determined through the conduct of a task analysis.

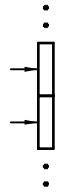
A.2 General workstation groupings

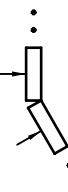
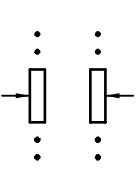
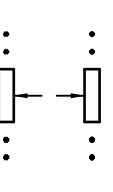
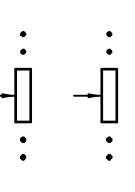

Workstation groupings	Linear one-sided	Arc, one-sided, operators inside	Arc, one-sided, operators outside	Linear or arc, two-sided (1 A)	Linear or arc, two-sided (1 B)	Linear or arc, two-sided (1 C)
Key Control workstation:  Viewing direction:  Further control workstations: 						
Features	Between operators			Between groups of operators		
Sharing workstation equipment	0	+	-	-	- ^a	-
Sharing off-workstation display	+	+	0	-	- ^c	+ ^b
Direct eye contact	-	-	0	+	-	-
Verbal communication	0	-	0	+	- ^a	- ^a
Noise interference	0	+	0	-	+	0
Message passing	0	+	-	-	0 ^a	- ^a
Collection and delivery of paperwork	+	+	+	+	-	-
Teamwork support	0	0	0	+	-	-
Separation of groups	-	-	-	+	+	+
Equipment access for maintenance	+	+	0	- ^d	+	0
Key Better + Average 0 Worse -	^a Operators shall turn around or move. ^b Careful positioning of workstations required for groups to share off-workstation displays. ^c Each group may share a separate display. ^d Depend on precise layout; better for arcs with operators outside; worse for arcs with operators inside.					

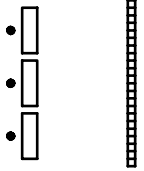
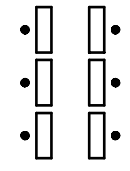
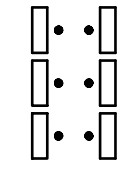
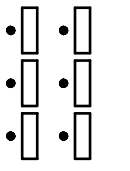
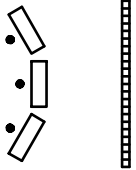
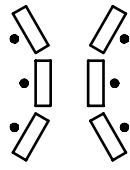
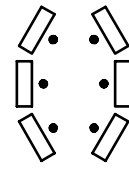
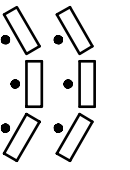
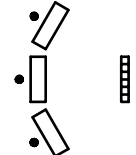
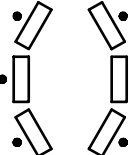
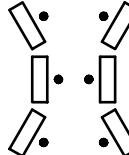
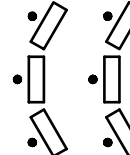
(continued)



Workstation groupings	Linear one-sided	Arc, one-sided, operators inside	Arc, one-sided, operators outside	Linear or arc, two-sided (1 A)	Linear or arc, two-sided (1 B)	Linear or arc, two-sided (1 C)
Linear examples						
Arc: operators inside						
Arc: operators outside						
Key Control operator ● Off-workstation display ▤ Control Workstation ▭						

A.3 Workstation groupings and supervisor positions

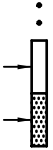
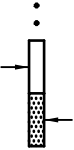
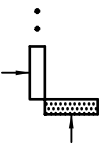
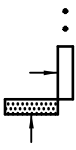
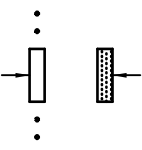
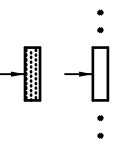

A.3.1

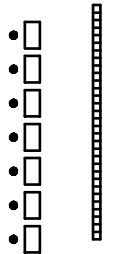
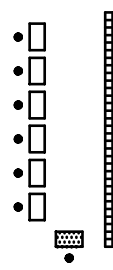
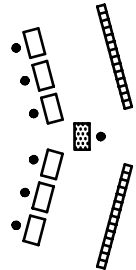
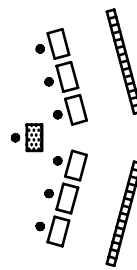
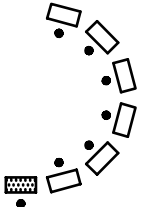
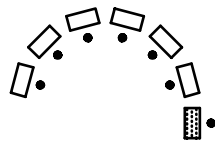
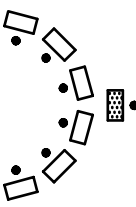
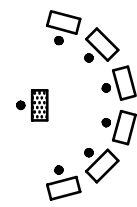
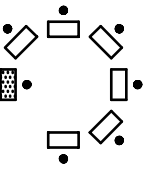
Supervisor locations	Linear or arc, one-sided (2 A)	Linear or arc, one-sided (2 B)	Linear or arc, one-sided (2 C)	Linear or arc, one-sided (2 D)	Linear or arc, one-sided (2 E)	Linear or arc, one-sided (2 F)
Key Control workstation:  Supervisor workstation:  Continuation: 						
Features	Between supervisors and operators					
Sharing workstation equipment	+ ^a	-	-	-	-	- _a
Sharing off-workstation display	+	-	0	- _b	- _b	+ ^b
Direct eye contact	-	0 ^c	+ ^c	-	+ ^c	-
Verbal communication	- _a	+ ^c	0 ^c	-	+ ^c	- _d
Noise interference	0	-	0	-	0	+
Message passing	+	+	0	0	-	-
Collection and delivery of paperwork	+	+	+	-	+	0
Standing in for supervisor	+ ^e	-	0 ^e	- _e	-	-
Operator training by supervisor	+ ^e	0 ^e	0 ^e	0 ^e	-	-
Equipment access for maintenance	+	+	+	-	+	0
Key Better + Average 0 Worse -	^a Depends on precise layout; better for arcs with operators inside; worse for arcs with operators outside. ^b Careful positioning of workstations required to view or share off-workstation displays. ^c Depends on precise layout; better for arcs with operators outside; worse for arcs with operators inside. ^d Operators shall turn around or move. ^e Better for operator adjacent to supervisor.					

(continued)

Supervisor locations	Linear or arc, one-sided (2 A)	Linear or arc, one-sided (2 B)	Linear or arc, one-sided (2 C)	Linear or arc, one-sided (2 D)	Linear or arc, one-sided (2 E)	Linear or arc, one-sided (2 F)
Linear examples						
Arc: operators inside						
Arc: operators outside						
Key User ● Off-workstation display 						

A.3.2

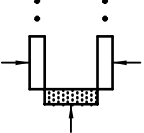
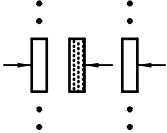
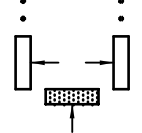
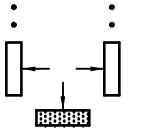
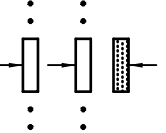
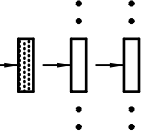
Supervisor locations	Linear or arc, two-sided (2 G)	Linear or arc, two-sided (2 H)	Linear or arc, two-sided (2 I)	Linear or arc, two-sided (2 J)	Linear or arc, two-sided (2 K)	Linear or arc, two-sided (2 L)
Key Control workstation:  Supervisor workstation:  Continuation: 						
Features	Between supervisors and operators					
Sharing workstation equipment	–	–	–	+	–	–
Sharing off-workstation displays	–	–	– ^a	–	– ^a	+ ^a
Direct eye contact	+ ^b	0 ^b	–	–	b	–
Verbal communication	+ ^d	0 ^c	0 ^{c, d}	–	+	– ^c
Low noise interference	–	–	0	+	–	+
Message passing	+	0	+	+	0	– ^c
Collection and delivery of paperwork	+	0	–	0	–	–
Standing in for supervisor	0 ^d	–	+ ^d	0 ^d	0	–
Operator training by supervisor	0 ^d	–	– ^d	+ ^d	–	0
Equipment access for maintenance	– ^b	– ^b	0	+	0	0
Key Better + Average 0 Worse –	^a Careful positioning of workstations required to view or share off-workstation displays. ^b Depends on precise layout; better for arcs with operators outside; worse for arcs with operators inside. ^c Operators or supervisor shall turn around or move. ^d Better for operators adjacent to supervisor.					

(continued)

Supervisor locations	Linear or arc, two-sided (2 G)	Linear or arc, two-sided (2 H)	Linear or arc, two-sided (2 I)	Linear or arc, two-sided (2 J)	Linear or arc, two-sided (2 K)	Linear or arc, two-sided (2 L)
Linear examples						
Arc: operators inside						
Arc: operators outside						
Key User ● Off-workstation display						

A.4 VDU's and window arrangements

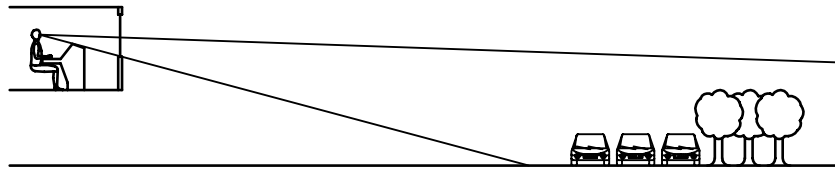

Figure A.1 — Recommended view out with direct view of sky reduced

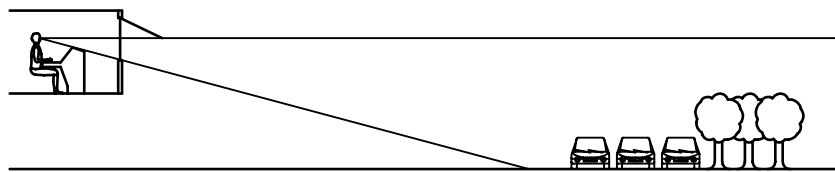
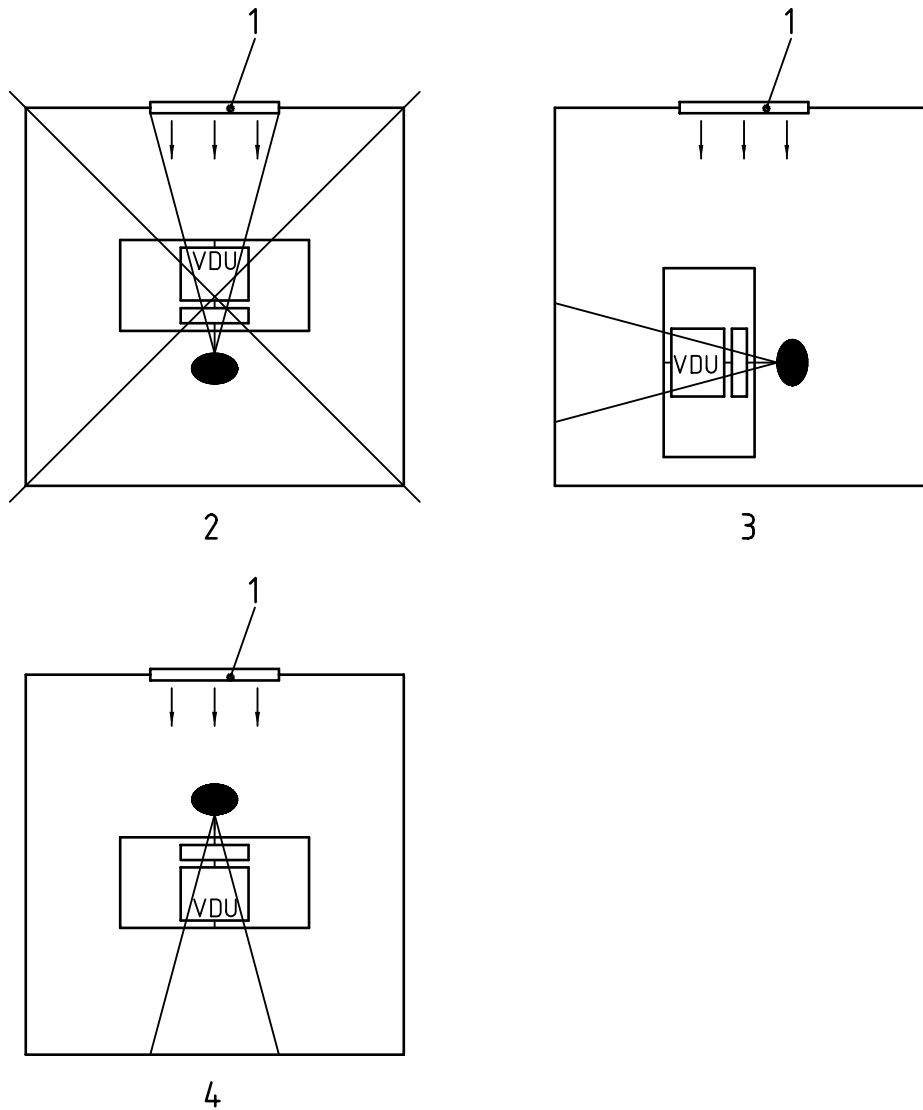

Figure A.2 — Use of awnings to reduce glare from the sky

NOTE The location of control workstations, housing display-screen equipment, in front of windows is generally to be avoided. However, there are sometimes operational reasons why operators need to see the scene outside using electronic visual displays.



Key

- 1 Window
- 2 Not recommended unless operationally required
- 3 A preferred arrangement of VDU and window
- 4 Arrangement may give rise to reflections on VDU

Figure A.3 — Types of arrangements

A.5 Guideline dimensions concerning wheelchair users

The basis for minimum circulation clearances for non-motorized, self-propelled wheelchair users is based on the clearances required for the width of the wheelchair, together with an allowance for elbow clearance for propelling the wheelchair [see Figure A.4].

Some typical allowances are presented in the table below

Allowances			
Notation ^a	Explanation	Restricted minimum mm	Preferred minimum mm
B	Length of wheelchair plus footrest and clearance	1 100	1 200
C	Width of wheelchair and elbow clearance	750	900

^a See Figure A.4.

Dimensions en millimètres

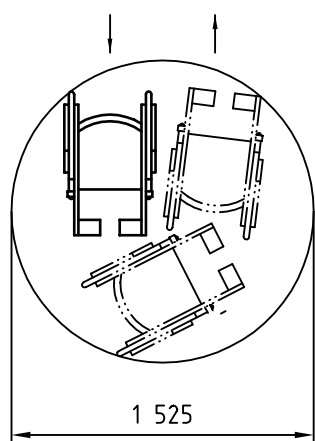

a) Minimum diameter for circular turning space

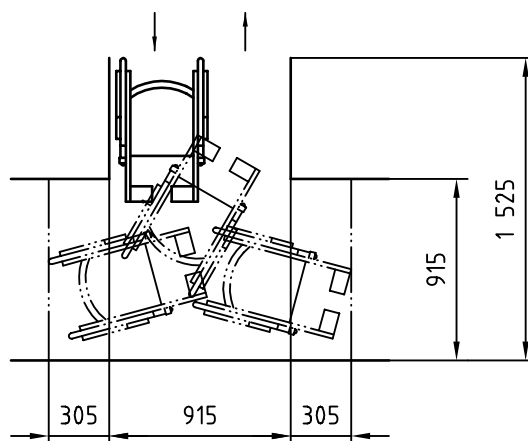

b) Minimum dimensions for T-shaped turning space

Figure A.4 — Turning space necessary for a wheelchair

Annex B (informative)

Anthropometric data of the world population

Human body measurements ^a	P5 ^b mm	P95 ^c mm
Stature (body height)	1 390	1 910
Sitting height	740	1 000
Eye height, sitting	620	880
Shoulder breadth (bideltoid) ^d	320	500
Shoulder breadth (bi-acromial)	285	430
Hip breadth (standing)	260	410
Knee height	405	600
Lower leg length (popliteal height)	320	505
Elbow-grip length	270	410
Buttock-knee length	450	670
Buttock-heel length	830	1 190
Hip breadth (sitting)	260	440
Foot length	200	300
<p>^a Source: Hans W. Jürgens, Ivar A. Aune, Ursula Pieper: International data on anthropometry, Occupational safety and health series No. 65, published by the International labour office, Geneva, Switzerland (see also ISO 7250).</p> <p>^b P5: 5th percentile (represents the physical size drawn from the "small type" population, i.e. only 5 % of the values lie below this lower limiting value).</p> <p>^c P95: 95 percentile (represents the physical size drawn from the "large type" population, i.e. only 5 % of the values lie above this upper limiting value).</p> <p>^d As an approximation, this measure is to be used for "elbow to elbow" dimension if no figures are available for the user population. The "elbow to elbow" width is the maximum breadth of the seated body, at elbow level, with the upper arms hanging vertically and the hands resting on the upper thighs.</p>		
<p>NOTE The table above covers the whole world population. Where available, equivalent user population data should be used.</p>		

Bibliography

- [1] *The Hidden Dimension*. Edward Hall, The Bodley Head, Great Britain (1966).
- [2] *Human Factors Guide for Nuclear Power Plant Control Room Development*. Final Report 1984, EPRI NP-3659. Essex Corporation.
- [3] WOODSON, W.E. *Human Factors Design Handbook*. McGraw Hill (1991).
- [4] JÜRGENS, Hans W., AUNE, Ivar A. and PIEPER, Ursula. *International data on anthropometry. Occupational safety and health series, No. 65*, International Labour Office, Geneva. English edition of the research report "Internationaler anthropometrischer Datenatlas", published by the Federal Institute for Occupational Safety and Health, Dortmund, Federal Republic of Germany. ISBN 92-2-106449-2. ISSN 0078-3129. First published 1990.
- [5] *The Guide to Reducing Human Error in Process Operations*, The SRD Association, ISBN 0-85356-357-8. (November 1991).
- [6] AINSWORTH, L.K. and KIRWAN, B., *A Guide to Task Analysis*. Taylor and Francis (1992).
- [7] *Nondiscrimination on the Basis of Disability by Public Accommodations and in Commercial Facilities: Final Rule*. Federal Register, Vol. 56, No. 144, 26 July, 1991, pp. 35544 to 35691.
- [8] STRAMLER, James H., Jr., *The Dictionary for Human Factors Ergonomics*. ISBN 0-8493-4236-8.
- [9] PHEASANT, S. *Bodyspace: Anthropometry, Ergonomics and Design*. Taylor and Francis. ISBN 0-85066-352-0 (1986).
- [10] EN 547-1:1996, *Safety of machinery — Human body measurements — Part 1: Principles for determining the dimensions required for openings for whole body access into machinery*.
- [11] EN 547-2:1996, *Safety of machinery — Human body measurements — Part 2: Principles for determining the dimensions required for access openings*.
- [12] EN 547-3:1996, *Safety of machinery — Human body measurements — Part 3: Anthropometric data*.
- [13] IEC 964:1989, *Design for control rooms of nuclear power plants*.
- [14] ISO 14738:—¹⁾, *Anthropometric requirements for the design of workstations at machinery*.

1) To be published.

ISO 11064-3:1999(E)

ICS 13.180

Price based on 35 pages

© ISO 1999 – All rights reserved