

---

---

**Prefilled syringes —**

**Part 6:  
Plastic barrels for injectables**

*Seringues préremplies —*

*Partie 6: Cylindres en plastique pour produits injectables*



Reference number  
ISO 11040-6:2012(E)

© ISO 2012



**COPYRIGHT PROTECTED DOCUMENT**

© ISO 2012

All rights reserved. Unless otherwise specified, no part of this publication may be reproduced or utilized in any form or by any means, electronic or mechanical, including photocopying and microfilm, without permission in writing from either ISO at the address below or ISO's member body in the country of the requester.

ISO copyright office  
Case postale 56 • CH-1211 Geneva 20  
Tel. + 41 22 749 01 11  
Fax + 41 22 749 09 47  
E-mail [copyright@iso.org](mailto:copyright@iso.org)  
Web [www.iso.org](http://www.iso.org)

Published in Switzerland

## Foreword

ISO (the International Organization for Standardization) is a worldwide federation of national standards bodies (ISO member bodies). The work of preparing International Standards is normally carried out through ISO technical committees. Each member body interested in a subject for which a technical committee has been established has the right to be represented on that committee. International organizations, governmental and non-governmental, in liaison with ISO, also take part in the work. ISO collaborates closely with the International Electrotechnical Commission (IEC) on all matters of electrotechnical standardization.

International Standards are drafted in accordance with the rules given in the ISO/IEC Directives, Part 2.

The main task of technical committees is to prepare International Standards. Draft International Standards adopted by the technical committees are circulated to the member bodies for voting. Publication as an International Standard requires approval by at least 75 % of the member bodies casting a vote.

Attention is drawn to the possibility that some of the elements of this document may be the subject of patent rights. ISO shall not be held responsible for identifying any or all such patent rights.

ISO 11040-6 was prepared by Technical Committee ISO/TC 76, *Transfusion, infusion and injection, and blood processing equipment for medical and pharmaceutical use*.

ISO 11040 consists of the following parts, under the general title *Prefilled syringes*:

- *Part 1: Glass cylinders for dental local anaesthetic cartridges*
- *Part 2: Plunger stoppers for dental local anaesthetic cartridges*
- *Part 3: Seals for dental local anaesthetic cartridges*
- *Part 4: Glass barrels for injectables*
- *Part 5: Plunger stoppers for injectables*
- *Part 6: Plastic barrels for injectables*

The following parts are under preparation:

- *Part 7: Packaging systems for prefillable ready-to-use syringes*

## Introduction

Until now, ampoules and injection bottles have been mainly used as primary packaging material for the administration of injectables. However, for the injection of the liquid medicinal products stored in these containers, a hypodermic syringe combined with the appropriate injection cannula is also needed. This requires that the medicinal product be transferred into the hypodermic syringe before its final use. This procedure is not only time-consuming; it can also easily result in mix-ups and possible contamination.

In conjunction with the appropriate sealing components, pre-filled single use syringes conforming to this part of ISO 11040 form a safe system for the transport, storage and administration of medicine. Due to relatively simple handling procedures, they permit fast injection of the medicinal products contained within them.

This part of ISO 11040 can also be used by engineers as a basis for the development and marketing of standardized filling and processing equipment, e.g. so-called tub and nest filling presentations. Manufacturers of filling equipment and ancillary processing equipment can use this part of ISO 11040 to achieve a certain degree of unification with regard to the design of these standardized items of equipment.

**NOTE** Primary packaging materials are an integral part of medicinal products. Thus, the principles of the current Good Manufacturing Practices (cGMP) apply to the manufacturing of these components (see ISO 15378).

# Prefilled syringes —

## Part 6: Plastic barrels for injectables

### 1 Scope

This part of ISO 11040 specifies the materials, dimensions and requirements for plastic barrels (single-chamber design) for injection preparations, which are to be subsequently filled and assembled on standardized processing equipment.

It is applicable to pre-filled plastic syringes intended for single use only.

Pre-filled syringes can be produced on dedicated and specifically designed processing equipment. This part of ISO 11040 is not applicable to such dedicated pre-filled syringes.

Before the final approval for human use is granted, compatibility tests applying the intended pharmaceuticals are carried out. This part of ISO 11040 does not specify the procedures for such compatibility tests.

### 2 Normative references

The following referenced documents are indispensable for the application of this document. For dated references, only the edition cited applies. For undated references, the latest edition of the referenced document (including any amendments) applies.

ISO 594-1, *Conical fittings with a 6 % (Luer) taper for syringes, needles and certain other medical equipment — Part 1: General requirements*<sup>1)</sup>

ISO 594-2, *Conical fittings with 6 % (Luer) taper for syringes, needles and certain other medical equipment — Part 2: Lock fittings*<sup>2)</sup>

ISO 7886-1:1993, *Sterile hypodermic syringes for single use — Part 1: Syringes for manual use*

ISO 10993-1, *Biological evaluation of medical devices — Part 1: Evaluation and testing within a risk management process*

ISO 11040-5, *Prefilled syringes — Part 5: Plunger stoppers for injectables*

ISO 15223-1:—<sup>3)</sup>, *Medical devices — Symbols to be used with medical device labels, labelling and information to be supplied — Part 1: General requirements*

ISO 15378:2011, *Primary packaging materials for medicinal products — Particular requirements for the application of ISO 9001:2000, with reference to Good Manufacturing Practice (GMP)*

European Pharmacopoeia 7, available at <http://www.edqm.eu>

1) To be replaced by ISO 80369-7, *Small-bore connectors for liquids and gases in healthcare applications — Part 7: Connectors with 6 % (Luer) taper for intravascular or hypodermic applications*, which is under preparation.

2) To be replaced by ISO 80369-7, *Small-bore connectors for liquids and gases in healthcare applications — Part 7: Connectors with 6 % (Luer) taper for intravascular or hypodermic applications*, which is under preparation.

3) To be published.

### 3 Dimensions and designation

#### 3.1 Dimensions of the barrel

The dimensions of the barrel shall be in accordance with Figure 1 and Table 1. These are the minimum required dimensions. Depending on the application, any other dimensions should be agreed between the manufacturer and the customer. Head designs of plastic barrels are shown in Annex A.

**Table 1 — Barrel dimensions**

Dimensions in millimetres

Nominal volume ml	Nominal dimension tolerances						
	$d_1$	$d_2^a$	$L$	$L_1$	$h_1$	$d_3$	$d_4$
0,5	6,8 to $8,2 \pm 0,1$ 6,8 to $9,4 \pm 0,1^b$	4,6 to $4,8 \pm 0,1$	57,0 to $64,8 \pm 0,2$	47,5 to $54,1 \pm 0,2$	1,8 to $2,1 \pm 0,1$	13,4 to $13,8 \pm 0,1$	10,5 to $11,0 \pm 0,1$
1 <sup>c</sup>	8,1 to $9,4 \pm 0,1$	6,3 to $6,5 \pm 0,1$	64,0 to $64,5 \pm 0,2$	54,0 to $54,5 \pm 0,2$	1,9 to $2,3 \pm 0,1$	13,7 to $13,8 \pm 0,1$	10,5 to $11,0 \pm 0,1$
1 <sup>d</sup>	10,8 to $11,4 \pm 0,1$	8,5 to $8,75 \pm 0,1$	45,9 to $46,9 \pm 0,2$	35,2 to $35,9 \pm 0,2$	1,9 to $2,3 \pm 0,1$	$17,75 \pm 0,1$	$14,70 \pm 0,1$
2,25	10,8 to $11,4 \pm 0,1$	8,5 to $8,75 \pm 0,1$	64,4 to $66,8 \pm 0,2$	53,9 to $54,6 \pm 0,2$	1,9 to $2,3 \pm 0,1$	$17,75 \pm 0,1$	$14,70 \pm 0,1$
3	10,8 to $11,4 \pm 0,1$	8,5 to $8,75 \pm 0,1$	82,4 to $84,6 \pm 0,2$	71,7 to $72,4 \pm 0,2$	1,9 to $2,3 \pm 0,1$	$17,75 \pm 0,1$	$14,70 \pm 0,1$
5	14,4 to $15,0 \pm 0,1$	11,7 to $12,2 \pm 0,1$	76,5 to $80,0 \pm 0,2$	64,3 to $66,7 \pm 0,2$	2,0 to $2,4 \pm 0,1$	22,9 to $23,1 \pm 0,1$	19,40 to $19,9 \pm 0,1$
10	16,6 to $18,0 \pm 0,1$	14,1 to $14,7 \pm 0,1$	97,7 to $100,5 \pm 0,2$	86,2 to $87,3 \pm 0,2$	2,0 to $2,4 \pm 0,1$	26,9 to $27,4 \pm 0,1$	21,50 to $21,9 \pm 0,1$
20	21,2 to $22,7 \pm 0,15$	18,9 to $19,1 \pm 0,15$	107,3 to $114,9 \pm 0,2$	95,6 to $96,8 \pm 0,2$	2,7 to $3,1 \pm 0,15$	32,25 to $38,8 \pm 0,15$	25,15 to $25,9 \pm 0,15$
50	29,2 to $32,3 \pm 0,2$	26,4 to $29,3 \pm 0,2$	128,8 to $151,2^e \pm 0,5$	118,7 to $128,2^e \pm 0,5$	2,7 to $3,1 \pm 0,2$	45,00 to $50,0 \pm 0,2$	33,2 to $39,10 \pm 0,2$
100	35,2 to $35,5 \pm 0,2$	31,8 to $32,2 \pm 0,2$	$169,8 \pm 0,5$	$156,4 \pm 0,5$	2,7 to $3,1 \pm 0,2$	$47,65 \pm 0,2$	$41,45 \pm 0,2$

<sup>a</sup> For the specification of the inner diameter, the specification of the plunger shall be considered with regard to break loose force and sustaining force. The size of the inner diameter also depends on the plastics material.

<sup>b</sup> This range is dedicated to barrels with an integrated Luer lock.

<sup>c</sup> Long.

<sup>d</sup> Short or standard.

<sup>e</sup> This range is required in order to consider particular applications, such as pumps and injectors.

**NOTE** When there are particular dimensional requirements, which is common when a syringe is used in combination with injectors, it is recommended that these requirements be agreed between the supplier and the customer.

Dimensions in millimetres

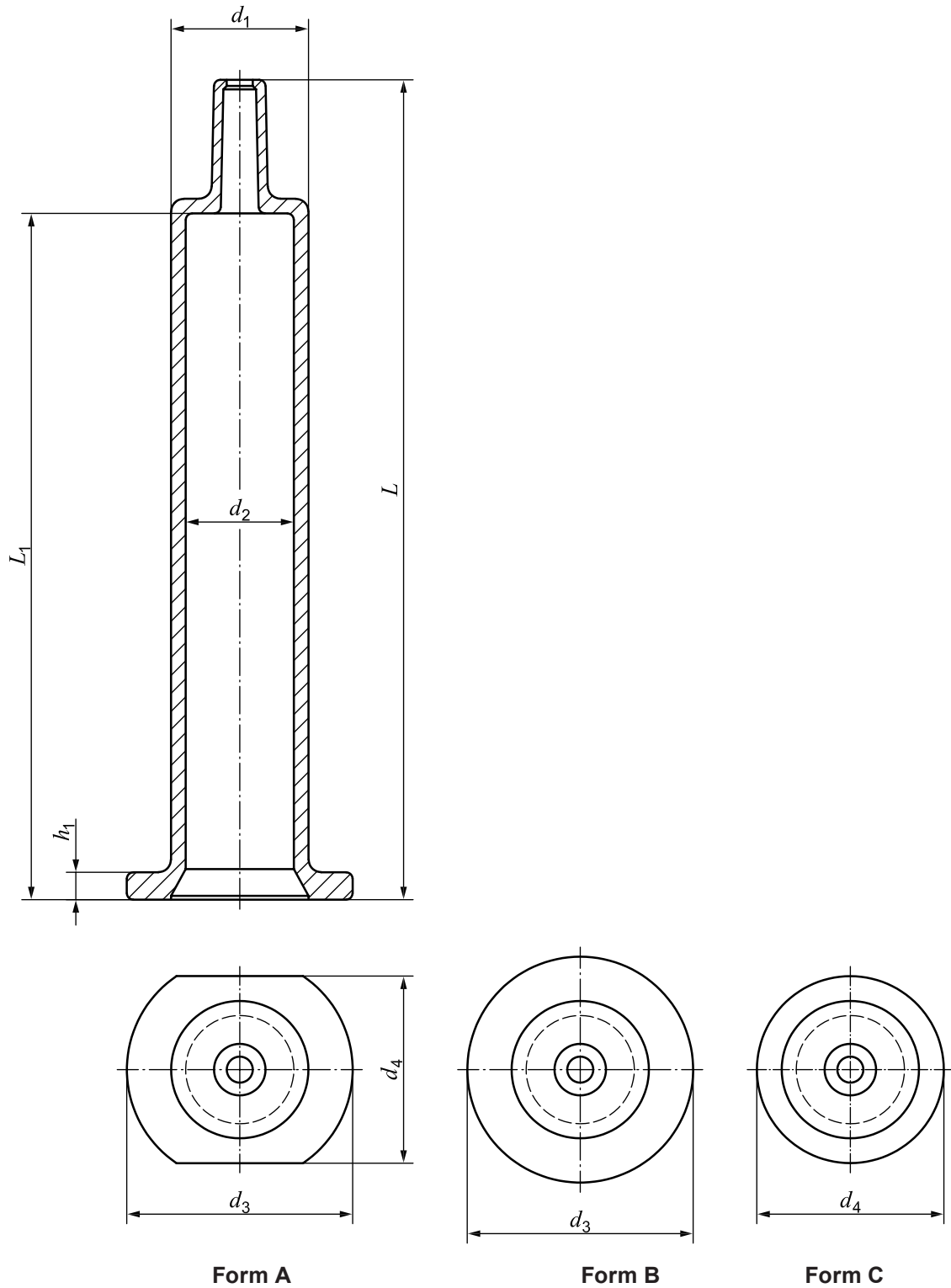

NOTE 1 Edges can be slightly rounded.

NOTE 2 The design of the finger flange is agreed between the manufacturer and the customer.

**Figure 1 — Typical example of a barrel and plastic finger flange for a pre-filled syringe**

## 3.2 Design

### 3.2.1 Head design

The type of head design shall be agreed upon between the provider of the barrel component and the company responsible for filling and finishing the plastic pre-filled syringe. For the Luer and the Luer lock design, ISO 594-1 and ISO 594-2 shall apply. Annex A includes certain examples of head designs.

### 3.2.2 Dead space

When tested in combination with the selected piston in accordance with ISO 11040-5, the dead space in the barrel and the nozzle with the piston fully inserted shall be as given in ISO 7886-1:1993, Table 1.

## 4 Requirements

### 4.1 General

The attention of the provider of the barrel component and the company responsible for filling and finishing the plastic pre-filled syringe is drawn to applicable performance requirements in monographs of, for example, the European Pharmacopoeia (Ph. Eur.), the United States Pharmacopoeia (USP) or the Japanese Pharmacopoeia (JP).

### 4.2 Material

#### 4.2.1 General

For the manufacturing of the barrels, suitable polymers shall be selected and used, based upon the intended application and processing techniques, which include, for example, the method of sterilization or the method of decontamination. The material shall exhibit the appropriate performance properties, e.g. oxygen and water permeability.

NOTE For guidance on materials, as well as polymer material codification, see Annex B.

#### 4.2.2 Duty of notification concerning modifications to polymers

For change control and notification procedures between the company transforming the polymer into a primary packaging material and the pharmaceutical company using it for injectable drug products, requirements given in ISO 15378:2011, 7.3.7 and 7.5.1.2 shall apply.

NOTE Particular attention is drawn to change control procedures and notification of changes by suppliers of raw material.

### 4.3 Physical requirements

#### 4.3.1 Sterilization

If the syringes are delivered sterile, they shall be sterilized using a suitable validated sterilization method. Suitable methods are given in ISO 11135-1, ISO 17665-1, ISO 11137 or ISO 14937.

#### 4.3.2 Clarity and transparency

The requirements and test method given in the Ph. Eur. 7, Section 3.2.8 shall apply.

Any possible colouring, for example regarding light shielding, shall be agreed between the user and the manufacturer of the primary packaging material.



### 4.3.3 Particulate contaminations

Syringes shall be manufactured such that any particulate contamination is avoided.

Current pharmacopoeias identify visible particulates as undesirable but do not define the size or put a limit on the allowable number. It is recommended that the supplier and the customer agree upon the size and number of visible particles and the test method.

NOTE See Ph. Eur. 7, 2.9.19, *Particulate contamination: sub-visible particles* and 2.9.20, *Particulate contamination: visible particles*; USP, General Chapter <788> *Particulate Matter in Injections*<sup>[16]</sup>; and JP, 6.06 *Foreign Insoluble Matter Test for Injections* and 6.07 *Insoluble Particulate Matter Test for Injections*<sup>[17]</sup>.

### 4.3.4 Lubricants

For silicone oil, attention is drawn to applicable quality and quantity requirements in respective pharmacopoeias. For other lubricants, appropriate in-house monographs shall be applied.

If the interior surfaces of the syringe barrel are lubricated, the lubricant shall not be visible, under normal or corrected-to-normal vision, as droplets or particles.

## 4.4 Chemical requirements

The materials used for manufacturing the syringes shall be chosen such that the risk of them releasing chemical constituents that can migrate into the injectables is minimized.

NOTE For limit values and test methods, see regional or national pharmacopoeias or the EMA Guideline for chemical constituents of extracts<sup>[18]</sup>.

For investigation of leachables and extractables of the syringe barrel, all packaging materials thereof in the same head space as the syringe barrel shall be considered. It shall be ensured that printing inks or adhesive labels used on the plastic syringes do not affect the performance of the syringe and its content.

## 4.5 Biological requirements

The material shall comply with biological requirements, i.e. toxic, cytotoxic, bacteriostatic, bactericidal, pyrogenic or haemolytic reactions, in accordance with relevant national or regional guidelines and standards.

NOTE In many countries, national or regional pharmacopoeias, state regulations or standards specify in detail suitable tests for assessing biological safety. Examples are the Ph. Eur., USP and JP.

The required tests shall be agreed in accordance with ISO 10993-1 between the manufacturer of the primary packaging material and the user.

## 5 Tolerance on graduated capacity

The tolerance on the graduated capacity shall be as given in ISO 7886-1:1993, Table 1.

## 6 Packaging and labelling

Each package shall have the following indications:

- a) manufacturer's name;
- b) article description;

NOTE A typical description is 1 ml long (l), 1 ml short or standard (s), staked needle (SN), Luer lock adaptor (LLA).

- c) quantity of syringes per item of packaging;
- d) date of manufacture;

## ISO 11040-6:2012(E)

e) manufacturer's batch number or symbol 5.1.5 in accordance with ISO 15223-1:—.

NOTE For packaging of the ready-to-use version, ISO 11040-7, which is currently under preparation, will apply.

**Annex A**  
(informative)

**Head designs**

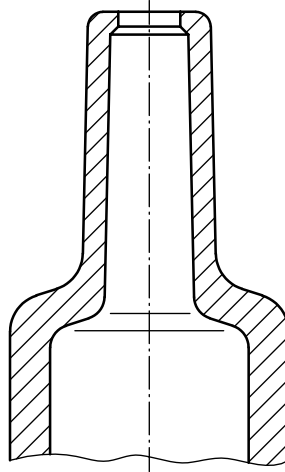

**Figure A.1 — Model A: Head design of a plastic barrel with a 6 % Luer taper in accordance with ISO 594-1**

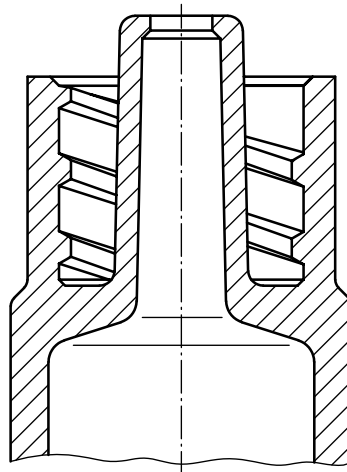

**Figure A.2 — Model B: Head design of a plastic barrel with a 6 % Luer taper for Luer lock in accordance with ISO 594-2**

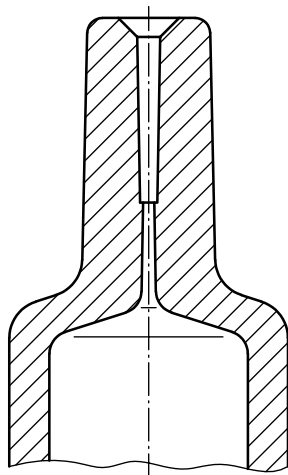

NOTE The bore can also be cylindrical.

**Figure A.3 — Model C: Head design of a plastic barrel for staked needle version**

## Annex B (informative)

### Guidance on materials

Materials used in the construction of syringe barrels for use in pre-filled syringes should be suitable for the process to be used, the sterilization method to be applied and for the specific requirements as primary packaging for injectable drug products. Materials used in the construction of pre-filled syringes should not cause the syringes to be detrimentally affected, physically or chemically, by the normal use of injectable preparations and should be safe for the intended use.

Certain grades of polypropylene (homo-polymer and/or co-polymer polypropylene), cyclo-olefin copolymer and cyclo-olefin polymer have been used for the barrels of pre-filled syringes in applications with a variety of injectable products (drugs and biologics).

The organization responsible for the marketing approval of the injectable drug product is required to demonstrate the appropriateness and compatibility of the selected material and the suitability of the prefillable syringe as a container closure system. This includes, among others, the verification of drug/container interactions (leachable, extractable and sorption assessments) in reference to regulatory guidance (e.g. FDA and EMA), pharmacopoeias and other guidelines (e.g. ICH).

To develop the necessary data as outlined above, a collaborative approach is recommended between the pharmaceutical company that holds the marketing authorization of the injectable product and the supplier of the packaging system, with reference to ISO 15378.

For polymer materials codification, see Table B.1.

**Table B.1 — Polymer materials codification**

Type of polymer	Codification
Cyclo-olefin copolymer	COC
Cyclo-olefin polymer	COP
Polypropylene	PP
Other polymer	OTH

## Bibliography

- [1] ISO 3826-1, *Plastics collapsible containers for human blood and blood components — Part 1: Conventional containers*
- [2] ISO 11040-4, *Prefilled syringes — Part 4: Glass barrels for injectables*
- [3] ISO 11040-7, *Prefilled syringes — Part 7: Packaging systems for prefillable ready-to-use syringes<sup>4)</sup>*
- [4] ISO 11135-1, *Sterilization of health care products — Ethylene oxide — Part 1: Requirements for development, validation and routine control of a sterilization process for medical devices*
- [5] ISO 11137 (all parts), *Sterilization of health care products — Radiation*
- [6] ISO 13926-2, *Pen systems — Part 2: Plungers and discs for pen-injectors for medical use*
- [7] ISO 14937, *Sterilization of health care products — General criteria for characterization of a sterilizing agent and the development, validation and routine control of a sterilization process for medical devices*
- [8] ISO 15747, *Plastics containers for intravenous injection*
- [9] ISO 17665-1, *Sterilization of health care products — Moist heat — Part 1: Requirements for the development, validation and routine control of a sterilization process for medical devices*
- [10] ISO 80369-7, *Small-bore connectors for liquids and gases in healthcare applications — Part 7: Connectors with 6 % (Luer) taper for intravascular or hypodermic applications<sup>5)</sup>*
- [11] ASTM D7210-06, *Standard Practice for Extraction of Additives in Polyolefin Plastics*
- [12] European guide for pharmaceutical products, III/2244/87, rev. 3 – January 1989 as amended
- [13] ICH Guideline, Harmonized Tripartite Guideline, Stability Testing for New Drug Substances and Products, <http://www.ich.org>
- [14] FDA, US Food and Drug Administration, <http://www.fda.gov>
- [15] ICH, International Conference on Harmonisation of Technical Requirements for Registration of Pharmaceuticals for Human Use, <http://www.ich.org>
- [16] United States Pharmacopoeia 34, <http://www.usp.org>
- [17] Japanese Pharmacopoeia, <http://www.pmda.go.jp/english/pharmacopoeia/index.html>
- [18] Guideline on Plastic Immediate Packaging Materials, European Medicines Agency, London, [http://www.ema.europa.eu/docs/en\\_GB/document\\_library/Scientific\\_guideline/2009/09/WC500003448.pdf](http://www.ema.europa.eu/docs/en_GB/document_library/Scientific_guideline/2009/09/WC500003448.pdf)
- [19] JENKE, D., *An extractables/leachables strategy facilitated by collaboration between drug product vendors and plastic material/system suppliers*, *PDA Journal of Pharmaceutical Science and Technology*, Vol. 61. No. 1, January-February 2007

---

4) Under preparation.

5) Under preparation.

Copyright International Organization for Standardization

---

---

**ICS 11.040.25**

Price based on 10 pages