Prefilled syringes —
Part 4:
Glass barrels for injectables

Seringues préremplies —

Partie 4: Cylindres en verre pour produits injectables



Reference number
ISO 11040-4:2007(E)

© ISO 2007

PDF disclaimer

This PDF file may contain embedded typefaces. In accordance with Adobe's licensing policy, this file may be printed or viewed but shall not be edited unless the typefaces which are embedded are licensed to and installed on the computer performing the editing. In downloading this file, parties accept therein the responsibility of not infringing Adobe's licensing policy. The ISO Central Secretariat accepts no liability in this area.

Adobe is a trademark of Adobe Systems Incorporated.

Details of the software products used to create this PDF file can be found in the General Info relative to the file; the PDF-creation parameters were optimized for printing. Every care has been taken to ensure that the file is suitable for use by ISO member bodies. In the unlikely event that a problem relating to it is found, please inform the Central Secretariat at the address given below.

© ISO 2007

All rights reserved. Unless otherwise specified, no part of this publication may be reproduced or utilized in any form or by any means, electronic or mechanical, including photocopying and microfilm, without permission in writing from either ISO at the address below or ISO's member body in the country of the requester.

ISO copyright office
Case postale 56 • CH-1211 Geneva 20
Tel. + 41 22 749 01 11
Fax + 41 22 749 09 47
E-mail copyright@iso.org
Web www.iso.org

Published in Switzerland

Foreword

ISO (the International Organization for Standardization) is a worldwide federation of national standards bodies (ISO member bodies). The work of preparing International Standards is normally carried out through ISO technical committees. Each member body interested in a subject for which a technical committee has been established has the right to be represented on that committee. International organizations, governmental and non-governmental, in liaison with ISO, also take part in the work. ISO collaborates closely with the International Electrotechnical Commission (IEC) on all matters of electrotechnical standardization.

International Standards are drafted in accordance with the rules given in the ISO/IEC Directives, Part 2.

The main task of technical committees is to prepare International Standards. Draft International Standards adopted by the technical committees are circulated to the member bodies for voting. Publication as an International Standard requires approval by at least 75 % of the member bodies casting a vote.

Attention is drawn to the possibility that some of the elements of this document may be the subject of patent rights. ISO shall not be held responsible for identifying any or all such patent rights.

ISO 11040-4 was prepared by Technical Committee ISO/TC 76, *Transfusion, infusion and injection equipment for medical and pharmaceutical use*.

This second edition cancels and replaces the first edition (ISO 11040-4:1996) which has been technically revised.

ISO 11040 consists of the following parts, under the general title *Prefilled syringes*:

- *Part 1: Glass cylinders for dental local anaesthetic cartridges*
- *Part 2: Plungers and discs for dental local anaesthetic cartridges*
- *Part 3: Aluminium caps for dental local anaesthetic cartridges*
- *Part 4: Glass barrels for injectables*
- *Part 5: Plungers for injectables*

Introduction

For the parenteral use of liquid pharmaceutical products, at present ampoules and injection vials are mainly used. However, for the injection of the liquid pharmaceutical products contained in those vials, a hypodermic syringe combined with the appropriate injection needle is also needed. This means the liquid pharmaceutical product has to be transferred to the hypodermic syringe before its final use. This procedure is not only time-consuming, but also presents a great number of possibilities for contamination.

To ensure safe use of a liquid pharmaceutical product, prefilled syringes for single use are already on the market. Without doubt, such prefilled syringes permit immediate injection of the product contained after relatively simple handling.

Based on diameter of the prefilled syringes, appropriate components, such as rubber plungers and aluminium caps, can also be standardized. The producers of filling machines can apply this part of ISO 11040 to achieve a degree of standardization in the equipment of the machines.

Prefilled syringes —

Part 4: Glass barrels for injectables

1 Scope

This part of ISO 11040 applies to tubing-glass barrels (single-chamber design) for injection preparations and specifies materials, dimensions and performance details.

Glass barrels from tubing glass in accordance with this part of ISO 11040 are intended for single use only. In conjunction with the right sealing components, they offer a safe system for parenteral use.

2 Normative references

The following referenced documents are indispensable for the application of this document. For dated references, only the edition cited applies. For undated references, the latest edition of the referenced document (including any amendments) applies.

ISO 594-1, *Conical fittings with a 6 % (Luer) taper for syringes, needles and certain other medical equipment — Part 1: General requirements*

ISO 594-2, *Conical fittings with 6 % (Luer) taper for syringes, needles and certain other medical equipment — Part 2: Lock fittings*

ISO 720:1985, *Glass — Hydrolytic resistance of glass grains at 121 °C — Method of test and classification*

ISO 4802-1:1988, *Glassware — Hydrolytic resistance of the interior surfaces of glass containers — Part 1: Determination by titration method and classification*

ISO 4802-2:1988, *Glassware — Hydrolytic resistance of the interior surfaces of glass containers — Part 2: Determination by flame spectrometry and classification*

3 Dimensions and designation

3.1 Dimensions

The dimensions of the glass barrel shall be as shown in Figure 1 and as given in Table 1 and in Annexes A and B.

3.2 Designation

The barrel designation shall comprise, in the following order, the descriptor "Barrel", a reference to this part of ISO 11040, the nominal volume, expressed in millilitres, the letters "lg" if the long version, a letter denoting the model and the glass colour.

EXAMPLE 1 A barrel with a nominal volume of 1 ml long version (lg) with a 6 % Luer taper tip design (model A) made of colourless glass (cl) complying with the requirements of this part of ISO 11040 is designated as follows:

Barrel ISO 11040-4 – 1 – lg – A – cl

EXAMPLE 2 A barrel with a nominal volume of 2 ml with 6 % Luer-lock taper tip design (model B) made of amber glass (br) complying with the requirements of this part of ISO 11040 is designated as follows:

Barrel ISO 11040-4 – 2 – B – br

EXAMPLE 3 A barrel with a nominal volume of 0,5 ml with a tip design for staked-needles (model C) made of colourless glass (cl) complying with the requirements of this part of ISO 11040 is designated as follows:

Barrel ISO 11040-4 – 0,5 – C – cl

4 Requirements

4.1 General

Where national or regional regulations exist, e.g. Ph. Eur. or USP, the glass tubing shall comply.

4.2 Material

4.2.1 The material shall be colourless (cl) or amber (br) glass of the hydrolytic resistance grain class HGA 1 in accordance with ISO 720:1985.

It shall correspond to glass type I of the European Pharmacopoeia and United States Pharmacopoeia.

4.2.2 If the glass tubing supplier intends to change the chemical composition or the colouring of the glass material, the user of the primary packaging material shall be provided with information and samples for testing at least nine months in advance. Additional requirements concerning change control should be agreed upon between the glass tubing supplier and the user of the primary packaging material.

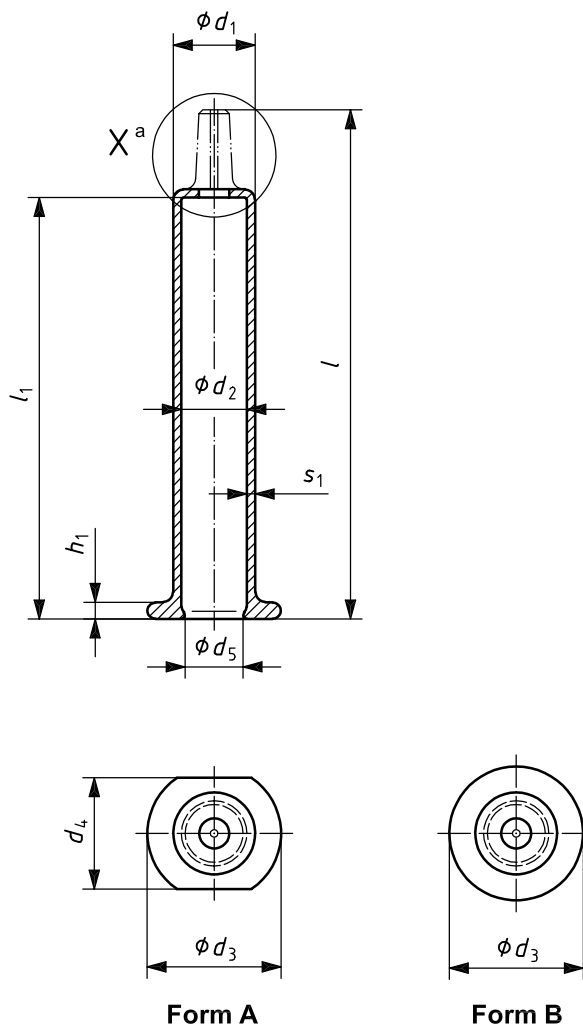

^a Detail X: see Figure A.1, Figure A.2 and Figure A.3.

NOTE The design of the finger-flange should be agreed between customer and manufacturer.

Figure 1 — Typical example of a glass barrel and glass finger-flanges for a prefilled syringe

Table 1 — Barrel dimensions

Dimensions in millimetres

Nominal volume ml	Glass barrel						Finger-flange								
	d_1		d_2		d_5	l_1		s_1	h_1		d_3		d_4		
	nom.	tol.	nom.	tol.	min.	nom.	nom.	tol.	≈	nom.	tol.	nom.	tol.	nom.	tol.
0,5	6,85		4,65	± 0,1	4,40	47,6	± 0,5		1,1	1,8	± 0,5	13,4	± 0,4	10,5	± 0,4
1 ^a	8,15		6,35		6,05	54		0,9	1,9	13,8		11			
1 ^b	10,85		8,65	± 0,2	8,25	35,7	± 0,5		1,1	2,2	± 0,5	17,75	± 0,75	14,7	± 0,5
2	10,85	± 0,1	8,65		8,25	49		1,1	2,2	17,75		14,7			
2,25	10,85		8,65		8,25	54,4		1,1	2,2	17,75		14,7			
3	10,85		8,65		8,25	72,2		1,1	2,2	17,75		14,7			
5	14,45		11,85	± 0,2	11,45	66,7	± 0,75		1,3	2,4	± 0,6	23	± 1	19,5	± 0,6
10	17,05		14,25		13,85	87,25		1,4	2,5	27		21,5			
20	22,05	± 0,2	19,05	18,40	96,8	1,5	3,1	32,25	25,9						

a Called long version.
b Called short/standard version.

4.3 Performance

4.3.1 Hydrolytic resistance

When tested in accordance with ISO 4802-1 or ISO 4802-2, the hydrolytic resistance of the internal surface of the glass barrel shall comply with the requirements of hydrolytic resistance container class ISO 4802-HC 1 (ISO 4802-1/-2:1988) or, if required, glass type I Ph. Eur.

Before conducting the test, the bottom end of the barrel shall be sealed with a suitable closure element, e.g. a silicon rubber closure.

4.3.2 Annealing quality

If the glass is annealed, the maximum residual stress shall not produce an optical retardation exceeding 40 nm/mm of glass thickness when the glass barrel is viewed in a strain viewer.

The test method for residual stress shall be agreed upon between glass manufacturer and customer.

5 Marking

Each package shall be labelled with the product code, designation, quantity and manufacturer's name.

Further marking, e.g. product batch number, shall be agreed upon between customer and manufacturer.

Annex A
(informative)

Head designs

Dimensions in millimetres

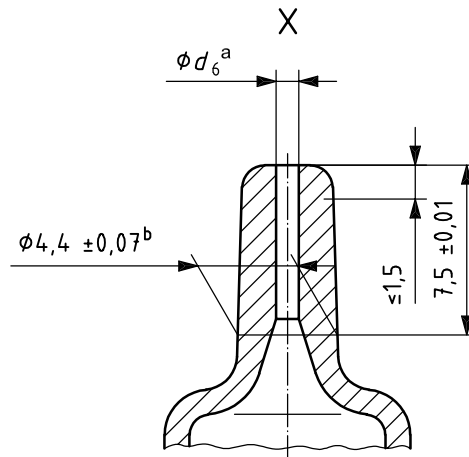

- a Agreed between customer and manufacturer.
- b Tolerance deviating from ISO 594-1.

Figure A.1 — Model A: head design of a glass barrel with a 6 % Luer cone in accordance with ISO 594-1

Dimensions in millimetres

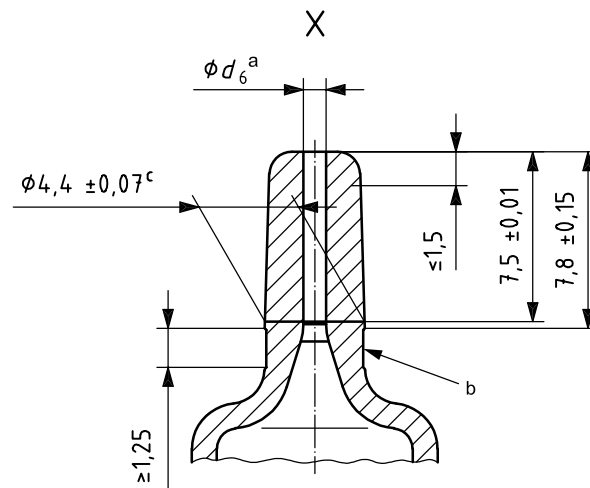

- a Agreed between customer and manufacturer.
- b Undercut min. 0,03 mm, edges clear formed.
- c Tolerance deviating from ISO 594-2.

Figure A.2 — Model B: head design of a glass barrel with a 6 % Luer cone for Luer-lock in accordance with ISO 594-2

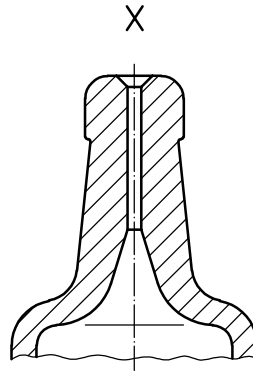

NOTE X dimension and internal shape of the bore are agreed upon between customer and manufacturer.

Figure A.3 — Model C: head design of a glass barrel for staked-needle version

© ISO 2007. All rights reserved.

Annex B (informative)

Barrel total length

Table B.1 — Barrel total length

Dimensions in millimetres

Nominal volume ml	Total length <i>l</i>	
	nom.	tol.
0,5	57,5	± 0,5
1 ^a	64,0	± 0,5
1 ^b	46,7	± 0,5
2	60,0	± 0,5
2,25	66,6	± 0,75
3	84,4	± 1,0
5	80,0	± 0,75
10	100,5	± 1,0
20	114,9	± 1,0
^a Called long version. ^b Called short/standard version.		

Bibliography

www.iso.org

- [1] ISO 11040-5, *Prefilled syringes — Part 5: Plungers for injectables*

ICS 11.040.25

Price based on 9 pages