**Equipment for crop protection —
Knapsack motorized air-assisted
sprayers — Test methods and
performance limits**

*Matériel de protection des cultures — Pulvérisateurs à dos motorisés à
jet porté — Méthodes d'essai et limites de performance*



Reference number
ISO 10988:2011(E)

© ISO 2011



COPYRIGHT PROTECTED DOCUMENT

© ISO 2011

All rights reserved. Unless otherwise specified, no part of this publication may be reproduced or utilized in any form or by any means, electronic or mechanical, including photocopying and microfilm, without permission in writing from either ISO at the address below or ISO's member body in the country of the requester.

ISO copyright office
Case postale 56 • CH-1211 Geneva 20
Tel. + 41 22 749 01 11
Fax + 41 22 749 09 47
E-mail copyright@iso.org
Web www.iso.org

Published in Switzerland

Contents

Page

Foreword	iv
1 Scope	1
2 Normative references	1
3 Terms and definitions	1
4 Requirements	2
4.1 General	2
4.2 Material of construction	2
4.3 Straps and their fixation points	2
4.4 Spray tank	2
4.5 Strainers and filters	3
4.6 Nozzles	3
4.7 Air hoses and chemicals hoses	3
5 Tests	3
5.1 Test liquids and equipment	3
5.2 Test conditions	4
5.3 Liquid flow rate	5
5.4 Volume of total residual liquid	5
5.5 Stability	5
5.6 Contents gauge scale and total tank volume	5
5.7 Filling	6
5.8 Air velocity and air volume	6
5.9 Droplet size	7
5.10 Potential ground deposit	8
5.11 Potential vertical deposit	8
5.12 Test for compatibility of sprayer components	8
6 Specifications and performance limits	9
6.1 Volume of residual liquid	9
6.2 Stability	9
6.3 Contents gauge scale and total tank volume	9
6.4 Filling	9
6.5 Liquid flow rate	9
6.6 Emptying	9
6.7 Compatibility of sprayer components	10
7 Instruction handbook	10
8 Test report	10
Annex A (informative) Sprayer locking device	11
Annex B (informative) Device for detecting potential vertical deposits	12
Annex C (normative) Stability test	13
Annex D (normative) Sampling grid position for air velocity determination	14
Annex E (informative) Position of sprayer and Petri dishes for potential ground deposit determination	15
Annex F (informative) Example test report	16
Bibliography	19

Foreword

ISO (the International Organization for Standardization) is a worldwide federation of national standards bodies (ISO member bodies). The work of preparing International Standards is normally carried out through ISO technical committees. Each member body interested in a subject for which a technical committee has been established has the right to be represented on that committee. International organizations, governmental and non-governmental, in liaison with ISO, also take part in the work. ISO collaborates closely with the International Electrotechnical Commission (IEC) on all matters of electrotechnical standardization.

International Standards are drafted in accordance with the rules given in the ISO/IEC Directives, Part 2.

The main task of technical committees is to prepare International Standards. Draft International Standards adopted by the technical committees are circulated to the member bodies for voting. Publication as an International Standard requires approval by at least 75 % of the member bodies casting a vote.

Attention is drawn to the possibility that some of the elements of this document may be the subject of patent rights. ISO shall not be held responsible for identifying any or all such patent rights.

ISO 10988 was prepared by Technical Committee ISO/TC 23, *Tractors and machinery for agriculture and forestry*, Subcommittee SC 6, *Equipment for crop protection*.

Equipment for crop protection — Knapsack motorized air-assisted sprayers — Test methods and performance limits

1 Scope

This International Standard specifies the requirements, test methods and minimum performance limits for knapsack motorized air-blast (twin-fluid) sprayers and air-assisted centrifugal sprayers as defined in ISO 5681.

It is applicable to those integrally powered knapsack sprayers, equipped with an engine and carried by the operator, intended primarily for use in agriculture and horticulture (hereafter referred to as “sprayers”).

It is not applicable to hydraulic pressure sprayers, thermal sprayers or cold foggers; nor is it applicable to sprayers adapted for the application of dry material.

It addresses general operating parameters as well as the potential deposition of spray droplets under specified controlled conditions. It does not deal with the safety of the operator in the use of the sprayers (see ISO 28139).

2 Normative references

The following referenced documents are indispensable for the application of this document. For dated references, only the edition cited applies. For undated references, the latest edition of the referenced document (including any amendments) applies.

ISO 5681, *Equipment for crop protection — Vocabulary*

ISO 9357:1990, *Equipment for crop protection — Agricultural sprayers — Tank nominal volume and filling hole diameter*

ISO 19932-1:2006, *Equipment for crop protection — Knapsack sprayers — Part 1: Requirements and test methods*

ISO 28139:2009, *Agricultural and forestry machinery — Knapsack combustion engine-driven mistblowers — Safety requirements*

3 Terms and definitions

For the purposes of this document, the terms and definitions given in ISO 5681, ISO 19932-1 and ISO 28139 apply.

4 Requirements

4.1 General

Knapsack motorized sprayers shall be so designed that they can be safely used in accordance with their intended purpose, achieve minimal exposure levels to the operator and avoid unnecessary waste of pesticides into the environment.

The sprayer shall be designed such that the liquid flow can be activated and switched off in accordance with ISO 28139:2009, 5.6.6.

It shall comply with the following requirements and shall meet the specifications in accordance with ISO 19932-1 as applicable.

The sprayer with the tank filled at nominal volume shall be designed such that the operator shall be able to pick it up, carry it and put it down in accordance with the instruction handbook and without any spillage.

It shall have an adjustable and reproducible spray liquid output.

Any components of the sprayer subject to maintenance, as specified in the instruction handbook, shall be changeable without special tools, unless these are provided with it.

The sprayer shall be designed such that the filled sprayer can be carried in the upright position.

It shall not be possible to displace any gasket or seal from its seated position by tightening.

4.2 Material of construction

All components of the sprayer made from plastic and elastomers coming into direct contact with the spray solution shall be capable of operating satisfactorily after the immersion test specified in 5.12.

4.3 Straps and their fixation points

Straps shall be made of non-absorbent material.

The straps shall be adjustable in length to meet the needs of the operator while on the operator's back. Each strap shall be adjustable to a length of at least 75 cm, as measured between the fixing points of each strap.

The load-bearing width of the straps shall be at least 50 mm.

4.4 Spray tank

In order to avoid chemical spillage during filling, the diameter of the filling opening shall be in accordance with ISO 9357:1990, Table 1.

Hose nipples fitted to the tank shall be able to withstand a test force of (13 ± 1) N, so as to avoid unintentional disconnection.

The spray tank shall have a volumetric content gauge scale as specified in ISO 9357.

The filling tank opening shall be fitted with a lid, which shall

- have a retainer,
- be able to be opened and closed without the use of a special tool, and
- be fitted with a holding device ensuring a closed position by means of a positive mechanical action (e.g. lids fixed by screw action).

It shall be possible to empty the tank of the sprayer without the need to invert the sprayer.

It shall be possible to empty the tank without contaminating the operator or parts of the sprayer.

The exit flow shall not be directed towards the operator.

The emptying device shall be guarded against unintentional opening.

The emptying device shall be able to be operated without the use of tools.

4.5 Strainers and filters

The sprayer tank shall have a strainer with a mesh width not greater than 2 mm.

Gaps between the spray tank filling opening and strainer, as well as openings within the strainer, shall not exceed 2 mm.

The liquid going from the tank to the nozzles shall be filtered. The mesh width of these filters shall be less than the narrowest diameter of the smallest size of nozzle to be used.

Filters shall be installed at a freely accessible place and shall have a surface area of at least 1 000 mm² to prevent frequent filter clogging. They shall be capable of being removed and easily cleaned without draining of the tank.

4.6 Nozzles

The pattern of sprayed liquid shall not change unintentionally during operation.

The nozzle shall be protected from external clogging during the storage and filling of the sprayer.

4.7 Air hoses and chemicals hoses

The ratio of the hose bends shall meet the limits established by the manufacturers of the hoses in the normal working position.

The hoses shall have no bends which hinder the flow of liquid or air.

The distance between the shut-off valve and the air-outlet section shall be no less than 400 mm.

The air hoses shall be flexible in order to be easily adjustable.

The fan inlet shall be designed such that the ingestion of foreign materials is avoided when the sprayer is on the ground.

5 Tests

5.1 Test liquids and equipment

5.1.1 Test liquids

5.1.1.1 **Clean water**, free from solids.

5.1.1.2 **Petrol**, as indicated by the manufacturer.

5.1.2 **Measuring cylinders** for measuring volumes up to 1 l with a maximum error of ± 10 ml.

ISO 10988:2011(E)

5.1.3 Weighing device, able to weigh up to 2 kg with a maximum error of $\pm 0,1$ g.

5.1.4 Timer (stopwatch), for measuring periods up to 5 min with a maximum error of $\pm 0,5$ s.

5.1.5 Temperature measurement device, able to measure temperatures up to 35 °C with a maximum error of $\pm 0,5$ °C.

5.1.6 Artificial targets

5.1.6.1 Petri dishes with an internal diameter ≥ 150 mm. Other artificial collectors which can ensure the same results may be used, in which case they shall be described in the test report.

5.1.6.2 Sponges (e.g. 200 mm \times 200 mm \times 10 mm).

5.1.7 Filling device (for an example, see ISO 19932-1:2006, Annex C).

5.1.8 Air velocity measuring device with a maximum error of 5 % of the measurement value.

5.1.9 Sprayer locking device with a minimum mass of 150 kg and able to guarantee the locking of the sprayer and its air tube in the test position (for an example, see Annex A).

5.1.10 Droplet size analyser, capable of characterizing droplet size spectra (e.g. laser light diffraction particle analyser).

5.1.11 Device for detecting potential vertical deposits, consisting of a frame (2 \times 2) m with 16 sponges spaced across a length of 200 mm (see Annex B).

5.2 Test conditions

5.2.1 General

Assemble the sprayer following the instruction handbook. Inspect for tightness the filling cap and all other operator-controlled couplings.

Before starting each test, ensure that the engine has been properly warmed up.

The tests shall be performed with one new specimen of the sprayer type at an air temperature of 10 °C to 30 °C and a relative air humidity of at least 50 %, without influence of wind or sunlight.

The test site shall be such as to ensure that the natural course of the jet produced by the machine being tested is not altered. The surface on which the tests are carried out shall be level and free of obstacles.

5.2.2 Sprayer position

See the indications reported for each test.

5.2.3 Engine speed

If the engine speed cannot be regulated, all tests shall be carried out at the maximum allowable engine speed.

If the engine has an adjustable throttle, additional tests shall be carried out at the engine speed recommended by the manufacturer in the instruction handbook.

WARNING — Running the engine in a closed environment can create an inhalation hazard.

5.3 Liquid flow rate

The sprayer shall be locked in the horizontal position using the sprayer locking device (5.1.9).

Position the sprayer in the upright position with the tank filled to its nominal volume, the air delivery tube horizontal, then at 80° above the horizontal, and with the tube fully extended. Run it at a number of engine revolutions per minute in accordance with 5.2.3.

Activate the sprayer in the operating position. Recover the liquid output for a pre-established time. Determine the amount of recovered liquid using a balance (5.1.3) or graduated cylinder (5.1.2).

The flow rate of the sprayer for each type/number of nozzles — both traditional and ULV (ultra-low volume), with and without flow-rate-boosting device, if any — shall be measured with a maximum error of 1 %. Record the flow rates in litres per minute (l/min). Repeat the test with the tank filled to half its nominal volume.

Alternatively:

- a) fill the tank to its nominal volume;
- b) activate the sprayer for the time necessary to empty half tank;
- c) determine the amount of liquid sprayed by tank re-filling.

The liquid flow from the sprayer output shall be guaranteed in all intended working conditions specified by the manufacturer.

5.4 Volume of total residual liquid

This test shall be carried out on a complete, empty sprayer.

Fill the spray tank with water to its nominal volume and, using the sprayer locking device (5.1.9), fix the sprayer in the upright position with the air delivery tube in the horizontal position. Activate the sprayer in operating conditions in accordance with 5.2.3. Close the shutoff valve when the spray cloud is visibly interrupted.

Determine the total quantity of liquid in the sprayer by emptying the tank and all parts potentially containing spraying liquid.

5.5 Stability

Position the empty sprayer on a flat, hard surface with an incline of $(8,5 \pm 0,2)^\circ$ (see Annex C).

Check the stability of the sprayer by rotating it at 90° intervals along its vertical axis.

Repeat the test with the spray tank filled to its nominal volume.

5.6 Contents gauge scale and total tank volume

Place the empty sprayer in the upright position and fix it using the sprayer locking device (5.1.9).

Measure and register the volume between the marks when filling the spray tank using a measuring cylinder (5.1.2). Continue until the spray tank is filled to its nominal volume.

Determine the scale error, E , for each graduation as a percentage in accordance with ISO 19932-1, using the following equation:

$$E = \frac{V_s - V_m}{V_s} \times 100$$

where

V_s is the volume according to the spray tank scale, in litres;

V_m is the measured volume of water poured into the tank, in litres.

As a second part to the test, fill the spray tank to the upper edge of the filling opening. Calculate the additional volume, V_A , of the spray tank as a percentage from:

$$V_A = \frac{V_t - V_n}{V_n} \times 100$$

where

V_t is the total volume, in litres;

V_n is the nominal volume, in litres.

5.7 Filling

This test shall be carried out on a complete, empty sprayer using the test procedure specified in ISO 19932-1:2006, 5.3.8.

Remove the lid while keeping the strainer in position.

Position a filling device (5.1.7) with its outlet placed (100 ± 5) mm above the filling opening. Position the sprayer with its straps opposite the filling device and with the line connecting the upper strap fixing points oriented perpendicularly to the axis of the filling device (see ISO 19932-1:2006, Annex C). The impact point of the test liquid shall be the centre of the filling opening.

Pour a volume of test liquid equal to the nominal spray tank volume from the filling device into the filling opening of the sprayer.

Determine the volume of the splash liquid.

5.8 Air velocity and air volume

The sprayer shall be locked in the upright position, with its air delivery tube in the horizontal position, using the sprayer locking device (5.1.9) such that the height of the centre of the sprayer spray outlet is $(1\ 000 \pm 20)$ mm from the ground.

Run the sprayer at an engine speed in accordance with 5.2.3.

Position the air velocity measuring device (5.1.8) at the centre of the air-outlet section.

Activate the sprayer and verify that the sprayer positioning is correct.

Perform the detection of the air velocity at distances of $(3\ 000 \pm 20)$ mm and $(6\ 000 \pm 20)$ mm from the air-outlet section, working on a grid sample of (100×100) mm ± 5 mm (see Annex D) and stopping the procedure when the air velocity value is lower than 2 m/s.

5.9 Droplet size

This test provides information on the droplet size spectra produced by the sprayer.

Using the sprayer locking device (5.1.9), lock the sprayer in the upright position with its air delivery tube in the horizontal position.

The droplet size spectrum can be measured with any non-intrusive system appropriate for the range of droplet size and velocity within the spray and the properties of the spraying liquid using measurement systems based on phase Doppler light scatter, laser diffraction or imaging principles. Other non-intrusive measurement systems may also be appropriate if they have a resolution and dynamic measurement range similar to the aforementioned laser instruments. The instrument and measurement system shall enable repeatable measurements for the reference sprays with a maximum deviation of $D_{v0,5}$ (volume median diameter) between replicate measurements of $\pm 5\%$ for the same setting and measuring situation.

During the measurement of all sprays, the spraying liquid shall have a temperature within $\pm 5\text{ }^\circ\text{C}$ of the ambient air temperature. The air and liquid temperatures and humidity shall be recorded at the time of measurement.

A representative cross-section average sample shall be obtained across the entire spray cloud, with droplet size measurement being conducted at a distance of 1 m from the nozzle outlet or at an appropriate distance when measuring a fully atomized spray.

For measuring systems using a point-wise measuring principle, such as phase Doppler devices, continuous or stepwise movement of the point of measurement relative to the spray is required in order to obtain a representative sample of droplets. These relative movements shall follow along one of the central axes of the spray cloud. One additional movement line shall be used at each side of one of the main axes, as shown in Figure 1. In the case of continuous relative movement, the forward speed shall be constant for all movement lines. For stepwise movement, the measuring time shall be the same at each measuring position. Forward speed, measuring time and/or number of discrete movement lines shall be adjusted to obtain a maximum deviation of $D_{v0,5}$ between replicate measurements of not more than $\pm 5\%$ and, where possible and appropriate, to sample at least 10 000 droplets per sprayer.

The height, h , and the width, w , of the spray plume at the measuring distance shall be determined visually or using water-sensitive paper.

The values of $D_{v0,1}$, $D_{v0,5}$ and $D_{v0,9}$ shall be reported.

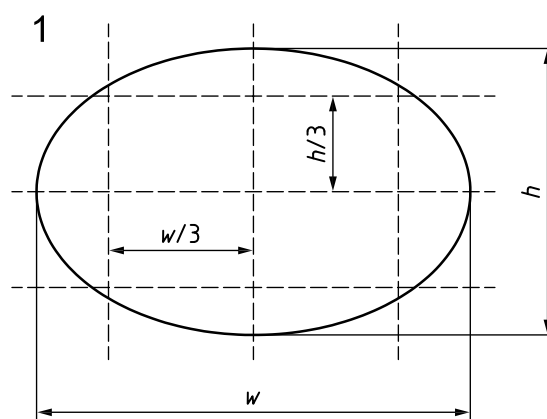

Key

- h height of spray cloud
- w width of spray cloud
- 1 spray cloud section

Figure 1 — Spray cloud section with lines of relative movement of point of measurement

5.10 Potential ground deposit

This test provides information on the spray ground deposit, produced indoors with the sprayer in a static condition and the spray outlet in the horizontal position.

Using the sprayer locking device (5.1.9), lock the sprayer in the upright position with its air delivery tube in the horizontal position such that the height of the centre of the sprayer spray outlet is $(1\ 000 \pm 20)$ mm from the ground (see Section A of Figure A.1).

The tests shall be performed indoors using the greatest and smallest liquid flow rates for standard sprayers as well as for ULV equipment. Each side wall of the indoor enclosure shall be located a minimum of 500 mm from the outermost Petri dishes (5.1.6.1).

Position a row of Petri dishes on the ground in correspondence with the symmetry axis of the air outlet. The first Petri dish shall be positioned at a 1 m distance from the spray outlet. The following Petri dishes shall be placed at (500 ± 5) mm intervals up to a distance of 12 m from the sprayer outlet. Position at least four additional Petri dishes for each of those mentioned above (two to the left and two to the right of each original dish) at distances of (250 ± 5) mm from one another. The number of additional Petri dishes (see the example given in Annex E) should be defined according to the dimension and shape of the surface sprayed.

Fill the sprayer tank to its nominal volume.

Verify its correct positioning and run the sprayer.

After operating the sprayer until the tank is empty, determine the amount of liquid in the Petri dishes by mass and express this as a ratio of the amount sprayed.

Other alternative methodologies may be used if they give the same results.

5.11 Potential vertical deposit

This test provides information on the potential vertical (spatial) distribution of the spray cloud.

Using the sprayer locking device (5.1.9), lock the sprayer in the upright position with its air delivery tube 90° above the horizontal (see Figure A.1, Section B).

Perform the tests indoors, or outdoors in the absence of wind, using the greatest and smallest liquid flow rates for standard sprayers as well as for ULV equipment.

Run the sprayer at an engine speed in accordance with 5.2.3.

Activate the sprayer and verify that the sprayer positioning is correct.

Using the device for detecting potential vertical deposits (5.1.11), check for such deposits at a distance of $(3\ 000 \pm 20)$ mm from the air-outlet section, stopping the procedure before the sponges become saturated.

Determine the amount of liquid recovered on the sponges by mass.

Other alternative methodologies may be used if they give the same results.

5.12 Test for compatibility of sprayer components

This test is used to determine any adverse effects on the material through the absorption of liquid or any visible effect (e.g. deformity) or change in physical properties (e.g. flexibility) or mass due to action of the test liquid on the material.

The test applies to samples of materials used in the manufacture of components that come into direct contact with the pesticides. The samples to be tested should be complete components, e.g. a whole "O" ring, washer

or gasket, a minimum length of 100 mm of tubing or a small section of a larger component such as a plastic container.

The mass of each sample of material shall be recorded before the test and again after immersion for 72 h at 20 °C to 25 °C. After the immersion period, any surplus liquid shall be wiped from the external surface and the samples dried in air at 20 °C to 25 °C for 24 h.

The samples shall be tested by immersion in

- a) $(10 \pm 0,5)$ % acetone in distilled water,
- b) a mixture of 50 % regular unleaded petrol and 50 % diesel fuel.

After these tests, any individual component removed from the equipment to conduct the test shall be re-assembled in the sprayer.

CAUTION — Care should be taken when performing tests with toxic and inflammable chemicals.

6 Specifications and performance limits

6.1 Volume of residual liquid

The volume of total residual liquid in the sprayer shall not exceed 250 ml.

Review the criteria taking into account that some sprayers are fitted with a pump.

6.2 Stability

The sprayer shall not fall over when tested in accordance with 5.5.

6.3 Contents gauge scale and total tank volume

The spray tanks shall have an additional volume of at least 5 % of the nominal volume.

The volumetric contents gauge scale shall have a maximum error of $\pm 7,5$ % up to a filling level of 20 % of the nominal volume and ± 5 % for greater filling levels.

6.4 Filling

The flow rate shall be such that the nominal tank volume will be poured into the sprayer spray tank within 30 s with a maximum deviation of 10 %.

The total volume of all splashes during filling shall not exceed 5 ml.

6.5 Liquid flow rate

Nozzles fitted to the sprayer shall give a flow rate of ± 15 % of the nominal value.

6.6 Emptying

The amount of liquid remaining in the sprayer shall not exceed 50 ml when tested in accordance with ISO 19932-1:2006, 5.3.9.

6.7 Compatibility of sprayer components

The change in mass of the samples after testing according to 5.12 shall not be more than 10 %.

The components shall not be deformed and when reassembled shall not leak and shall function normally.

7 Instruction handbook

The instruction handbook shall be in accordance with ISO 28139:2009, 7.3, and shall give the name and address of the sprayer manufacturer and the type of sprayer.

The instructions shall provide the following information:

- a) precautions to be taken during mixing, loading, application, emptying, cleaning, servicing and transport operations in order to avoid contamination of the environment;
- b) detailed conditions of use for the different operating environments envisaged, including the corresponding preparation and adjustments required to ensure the deposition of pesticide on target areas while minimizing losses to other areas, prevent drift to the environment and, where appropriate, ensure an even distribution and homogeneous deposition of pesticide;
- c) the range of types and sizes of nozzles, strainers and filters that can be used with the machinery;
- d) the frequency of checks and the criteria and method for the replacement of parts subject to wear that affect the correct functioning of the machinery, such as nozzles, strainers and filters;
- e) specification of calibration, daily maintenance, winter preparation and other checks necessary to ensure the correct functioning of the machinery;
- f) types of most widely used pesticides that can cause incorrect functioning of the machinery;
- g) an indication that the operator should update the name of the pesticide currently in use;
- h) the connexion and use of any special equipment or accessories and the necessary precautions to be taken;
- i) an indication that the machinery may be subject to national or regional requirements for regular inspection by designated bodies;
- j) the features of the machinery which are to be inspected to ensure its correct functioning;
- k) instructions for connecting the necessary measuring instruments.

8 Test report

The results of the tests shall be stated in a test report. See Annex F for an example.

Annex A
(informative)

Sprayer locking device

See Figure A.1 for an example.

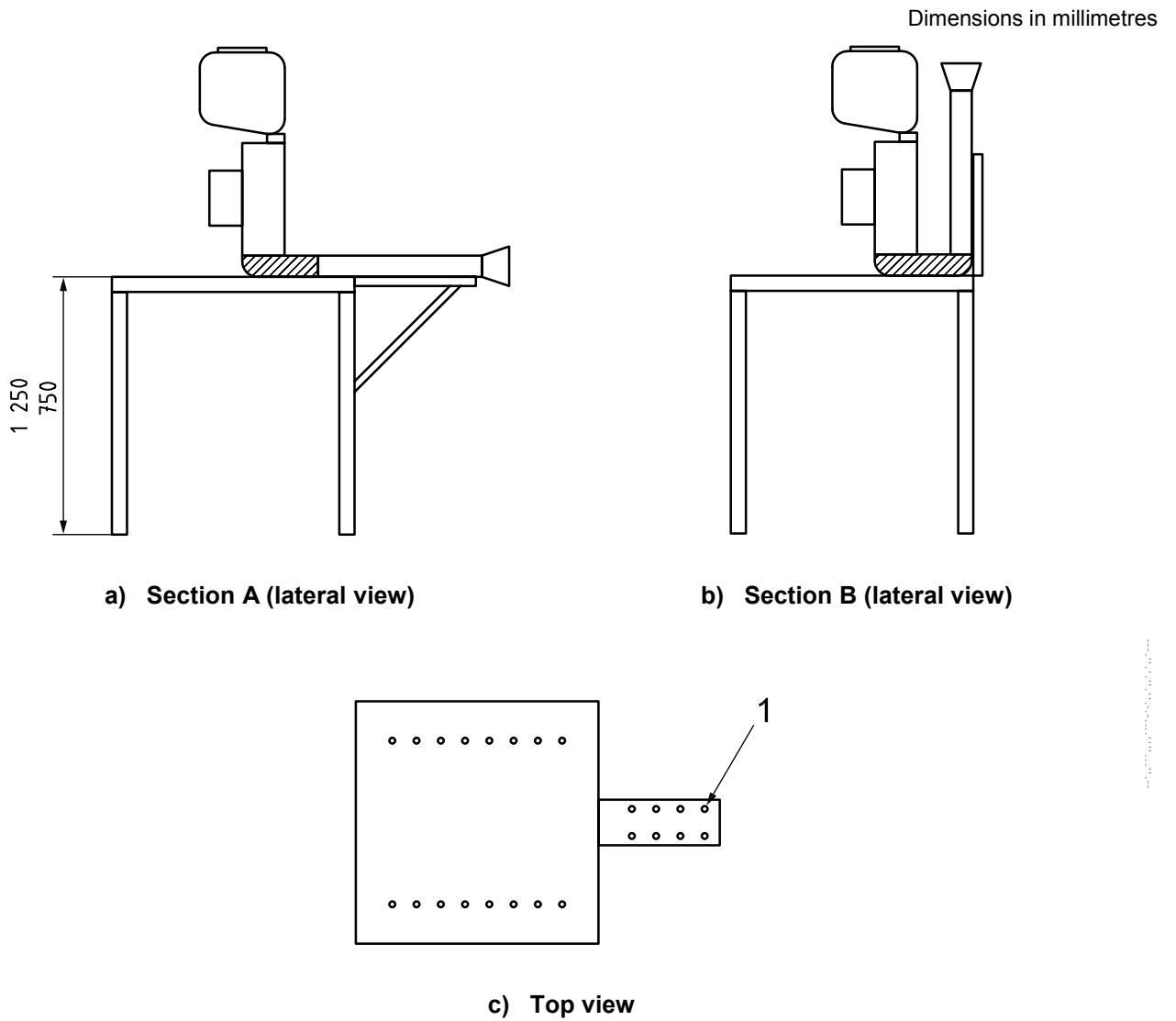

Key

1 holes for locking

Figure A.1 — Example of sprayer locking device

Annex B (informative)

Device for detecting potential vertical deposits

See Figure B.1 for an example.

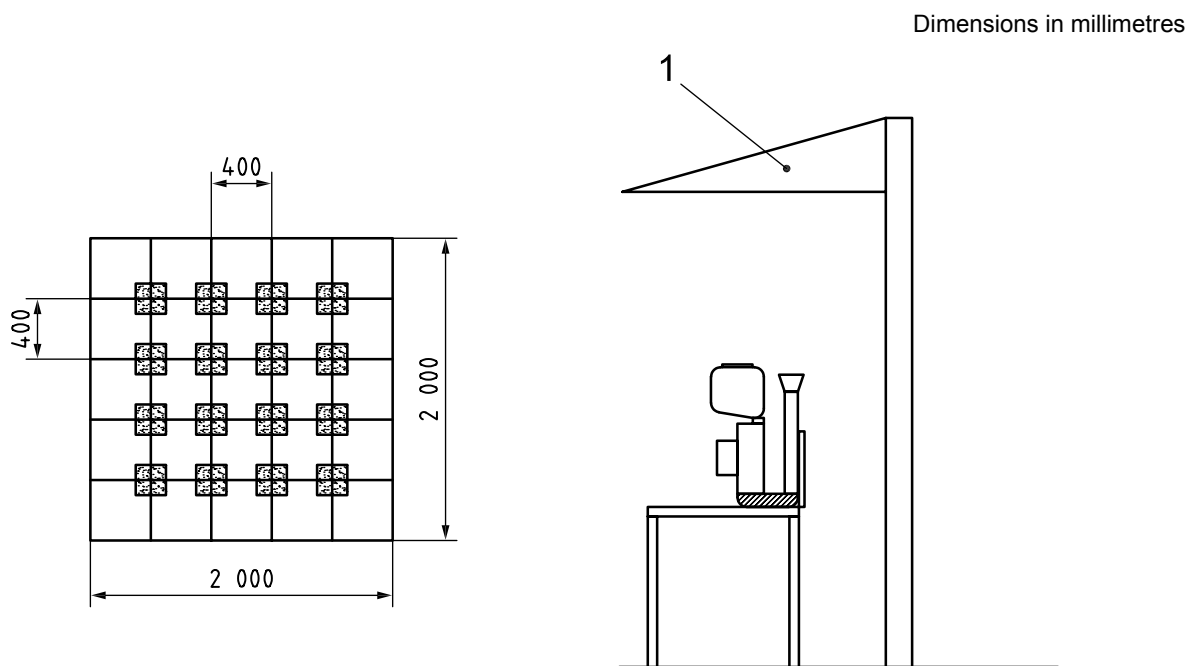

Key

- 1 device with sponges

Figure B.1 — Example of device for detecting potential vertical deposits

Annex C (normative)

Stability test

The sprayer shall be positioned in accordance with Figure C.1.

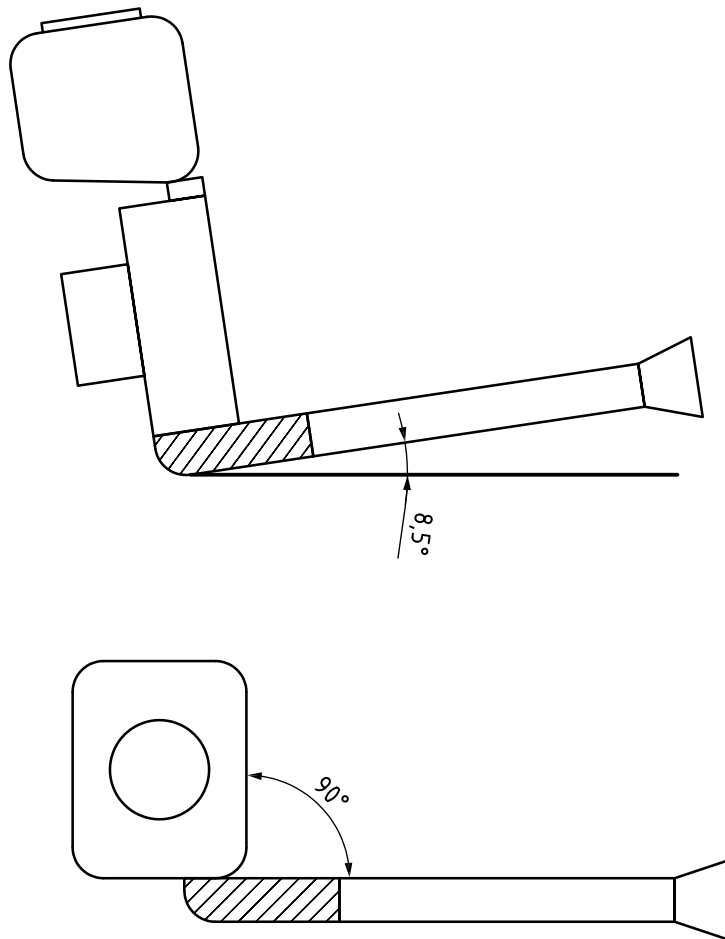

Figure C.1 — Position of sprayer for stability testing

Annex D (normative)

Sampling grid position for air velocity determination

The sampling grid position shall be in accordance with Figure D.1.

Dimensions in millimetres

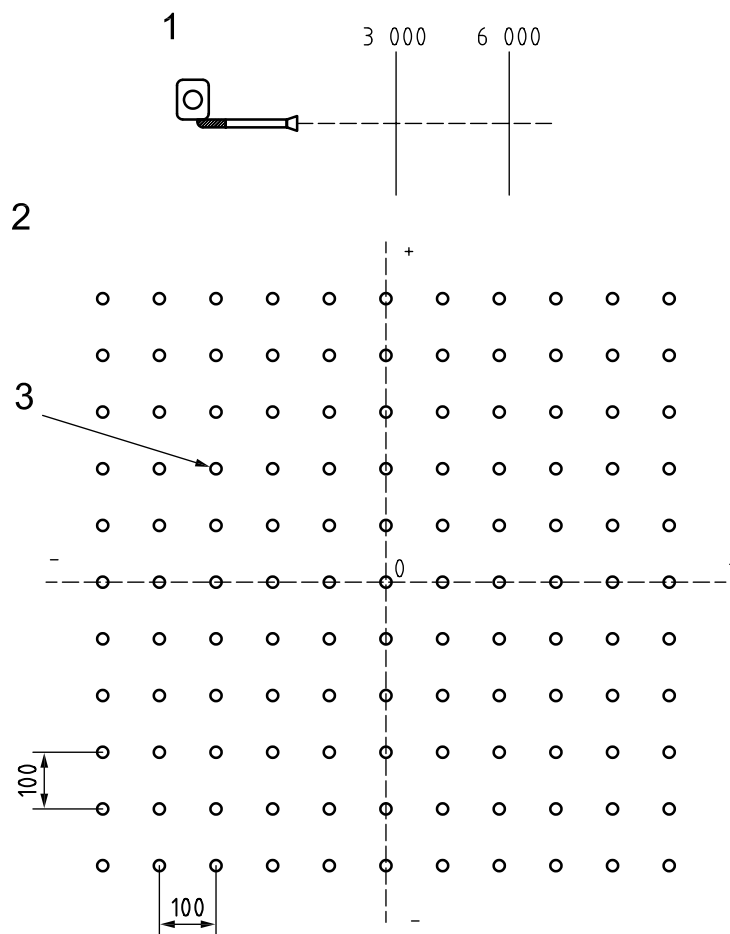

Key

- 1 air velocity sampling area
- 2 sampling area
- 3 air velocity sampling point

Figure D.1 — Sampling grid position for air velocity determination

Annex E
(informative)

Position of sprayer and Petri dishes for potential ground deposit determination

See Figure E.1 for an example.

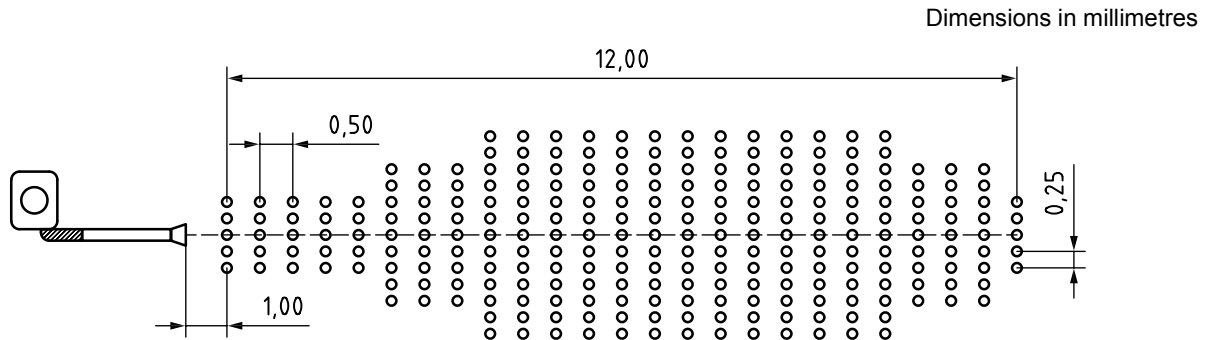

Figure E.1 — Example of sprayer and Petri dish positioning

Annex F
(informative)

Example test report

Report on knapsack motorized sprayer tests according to ISO 10988

Testing organization (name and address):	
Test location:	Date:

Sprayer		
Sprayer type:		Manufacturer:
Design:	Air-blast sprayers []	Air-assisted centrifugal sprayers []
Nominal tank volume (l):		
Mass of the complete, empty sprayer (kg):		
Nozzle:	Standard []	ULV []
Number of adjustments:		
Remarks:		

Test conditions	
Minimum temperature (°C):	Min. relative humidity (%):
Maximum temperature (°C):	Max. relative humidity (%):

Liquid flow rate				
Nozzle type	Adjustment	Stated output rate (l/min)	Measured output rate (l/min)	Deviation (%)

Volume of total residual			
Mass of the sprayer after test (g):			
Volume of total residual (ml):			
Remarks:			
Stability			
Tank filling level	Sprayer position	Stability	
Empty	strap side down the slope	Yes <input type="checkbox"/>	No <input type="checkbox"/>
	left side down the slope	Yes <input type="checkbox"/>	No <input type="checkbox"/>
	strap side up the slope	Yes <input type="checkbox"/>	No <input type="checkbox"/>
	right side down the slope	Yes <input type="checkbox"/>	No <input type="checkbox"/>
Nominal	strap side down the slope	Yes <input type="checkbox"/>	No <input type="checkbox"/>
	left side down the slope	Yes <input type="checkbox"/>	No <input type="checkbox"/>
	strap side up the slope	Yes <input type="checkbox"/>	No <input type="checkbox"/>
	right side down the slope	Yes <input type="checkbox"/>	No <input type="checkbox"/>
Remarks:			
Filling rate			
Pouring flow rate (l/min):			
Mass of plastic sheet and/or tissue before test (tare) (g):			
Mass of plastic sheet and/or tissue after test (g):			
Mass of splashes (g):			
Volume of splashes (ml):			
Remarks:			
Emptying			
Mass of the sprayer after test (g):			
Volume of remaining liquid (ml):			
Remarks:			

Spray tank contents gauge				
Scale mark, V_s (l)	Filling volume (l)	Volume increment, V_m (l)	Deviation ($V_s - V_m$) (l)	Error (%)
1				
2				
3				
4				
5				
6				
7				
8				
9				
10				
11				
12				
13				
14				
15				
Remarks:				
Total volume				
Mass of completely filled sprayer (g):				
Total volume (l):				
Additional volume percentage, V_A (%):				
Remarks:				
Compatibility of sprayer components				
Type of sample	Type of liquid for immersion	Mass before	Mass after	Mass change (%)
Damage Yes <input type="checkbox"/> No <input type="checkbox"/>				
Remarks:				

Bibliography

- [1] ISO 19932-2:2006, *Equipment for crop protection — Knapsack sprayers — Part 2: Performance limits*
- [2] *Equipment for vector control — Specification guidelines*. Department of Control of Neglected Tropical Diseases, WHO Pesticide Evaluation Scheme (WHOPES). World Health Organisation, 2006

.....

ICS 65.060.40

Price based on 19 pages