

First edition
2011-08-01

**Fibre-cement corrugated sheets and
fittings for roofing and cladding**

*Plaques ondulées en fibrociment et leurs accessoires pour couvertures
et revêtements*



Reference number
ISO 10904:2011(E)

© ISO 2011



COPYRIGHT PROTECTED DOCUMENT

© ISO 2011

All rights reserved. Unless otherwise specified, no part of this publication may be reproduced or utilized in any form or by any means, electronic or mechanical, including photocopying and microfilm, without permission in writing from either ISO at the address below or ISO's member body in the country of the requester.

ISO copyright office
Case postale 56 • CH-1211 Geneva 20
Tel. + 41 22 749 01 11
Fax + 41 22 749 09 47
E-mail copyright@iso.org
Web www.iso.org

Published in Switzerland

Contents

Page

Foreword	iv
Introduction.....	v
1 Scope	1
2 Normative references	1
3 Terms and definitions	2
4 Symbols, abbreviations and units	4
5 Product requirements	6
5.1 General	6
5.2 Categorization and classification	6
5.3 Dimensions and tolerances on nominal dimensions	8
5.4 Physical requirements and characteristics	9
5.5 Requirements concerning fire behavior	12
5.6 Product performance	12
5.7 Requirements concerning impact resistance.....	12
6 Evaluation of conformity	12
6.1 General	12
6.2 Type testing	12
6.3 Quality control (QC) system	13
6.4 Inspection of a consignment of finished products	15
7 Test requirements	15
7.1 General	15
7.2 Dimensional and geometrical tests	15
7.3 Physical performance tests.....	16
8 Marking.....	21
Annex A (normative) Consignment and inspection sampling	22
Annex B (normative) Dimensional and geometrical testing procedures.....	23
Annex C (normative) Test method to determine the breaking load and the bending modulus of sheets	31
Annex D (normative) Test method to determine the bending moment of a sheet.....	35
Annex E (normative) Statistical method for determining the corresponding wet values or revised dry specifications for the breaking load and/or bending moment when carrying out the dry method of test or when testing prior to coating for quality control purposes.....	37
Annex F (normative) Test method to determine the apparent density	40
Annex G (normative) Test method to determine the water permeability of a sheet.....	42
Annex H (normative) Test method to determine the freeze-thaw performance of sheets and fittings.....	44
Annex I (normative) Test method to determine the heat-rain performance of sheets.....	47
Annex J (normative) Test method to determine the warm water performance of long and short sheets	49
Annex K (normative) Test method to determine the soak-dry performance of long and short sheets	51
Bibliography.....	53

Foreword

ISO (the International Organization for Standardization) is a worldwide federation of national standards bodies (ISO member bodies). The work of preparing International Standards is normally carried out through ISO technical committees. Each member body interested in a subject for which a technical committee has been established has the right to be represented on that committee. International organizations, governmental and non-governmental, in liaison with ISO, also take part in the work. ISO collaborates closely with the International Electrotechnical Commission (IEC) on all matters of electrotechnical standardization.

International Standards are drafted in accordance with the rules given in the ISO/IEC Directives, Part 2.

The main task of technical committees is to prepare International Standards. Draft International Standards adopted by the technical committees are circulated to the member bodies for voting. Publication as an International Standard requires approval by at least 75 % of the member bodies casting a vote.

Attention is drawn to the possibility that some of the elements of this document may be the subject of patent rights. ISO shall not be held responsible for identifying any or all such patent rights.

ISO 10904 was prepared by Technical Committee ISO/TC 77, *Products in fibre reinforced cement*.

This first edition of ISO 10904 cancels and replaces ISO 9384:1991 and ISO 9933:1995, which have been technically revised.

© ISO 2011

Introduction

The performance of a roof or another building part constructed with the products covered by this International Standard depends not only on the properties of the products as required by this International Standard, but also on the design, construction and installation of the components as a whole relative to the environment and the conditions of use.

This International Standard does not include calculations with regard to works, design requirements, installation techniques, wind uplift or rain proofing of the installed sheets.

1

Fibre-cement corrugated sheets and fittings for roofing and cladding

1 Scope

This International Standard specifies technical requirements and methods for the inspection and testing of straight short and long fibre-cement profiled sheets and their fibre-cement fittings designed to provide the weather-exposed surfaces on roofs and internal and external walls of buildings.

Products covered by this International Standard can be used for other purposes, provided they comply with the appropriate national or international application code or standard.

Some of the requirements of this International Standard can apply, after agreement between manufacturer and purchaser, to curved profiled sheets.

The type tests described in this International Standard are not intended to evaluate the performance of the coating in isolation (colour-fastness, adhesion, etc.). Specific performance requirements for coatings are referenced in other International Standards or national standards.

This International Standard does not apply to fibre-cement profiled sheets and fittings reinforced with asbestos fibres.

2 Normative references

The following referenced documents are indispensable for the application of this document. For dated references, only the edition cited applies. For undated references, the latest edition of the referenced document (including any amendments) applies.

ISO 390:1993, *Products in fibre-reinforced cement — Sampling and inspection*

ISO 2602:1980, *Statistical interpretation of test results — Estimation of the mean — Confidence interval*

ISO 2859-1, *Sampling procedures for inspection by attributes — Part 1: Sampling schemes indexed by acceptance quality limit (AQL) for lot-by-lot inspection*

ISO 3951-1, *Sampling procedures for inspection by variables — Part 1: Specification for single sampling plans indexed by acceptance quality limit (AQL) for lot-by-lot inspection for a single quality characteristic and a single AQL*

ISO 12468-1, *External exposure of roofs to fire — Part 1: Test method*

ISO 12468-2, *External fire exposure to roofs — Part 2: Classification of roofs*

EN 15057, *Fibre cement profiled sheets — Impact resistance test method*

3 Terms and definitions

For the purposes of this document, the following definitions apply.

3.1 profiled sheet

component whose cross-section consists of corrugations

NOTE 1 Examples are shown in Figure 1.

NOTE 2 The corrugations are defined by their pitch, a , and their height, h .

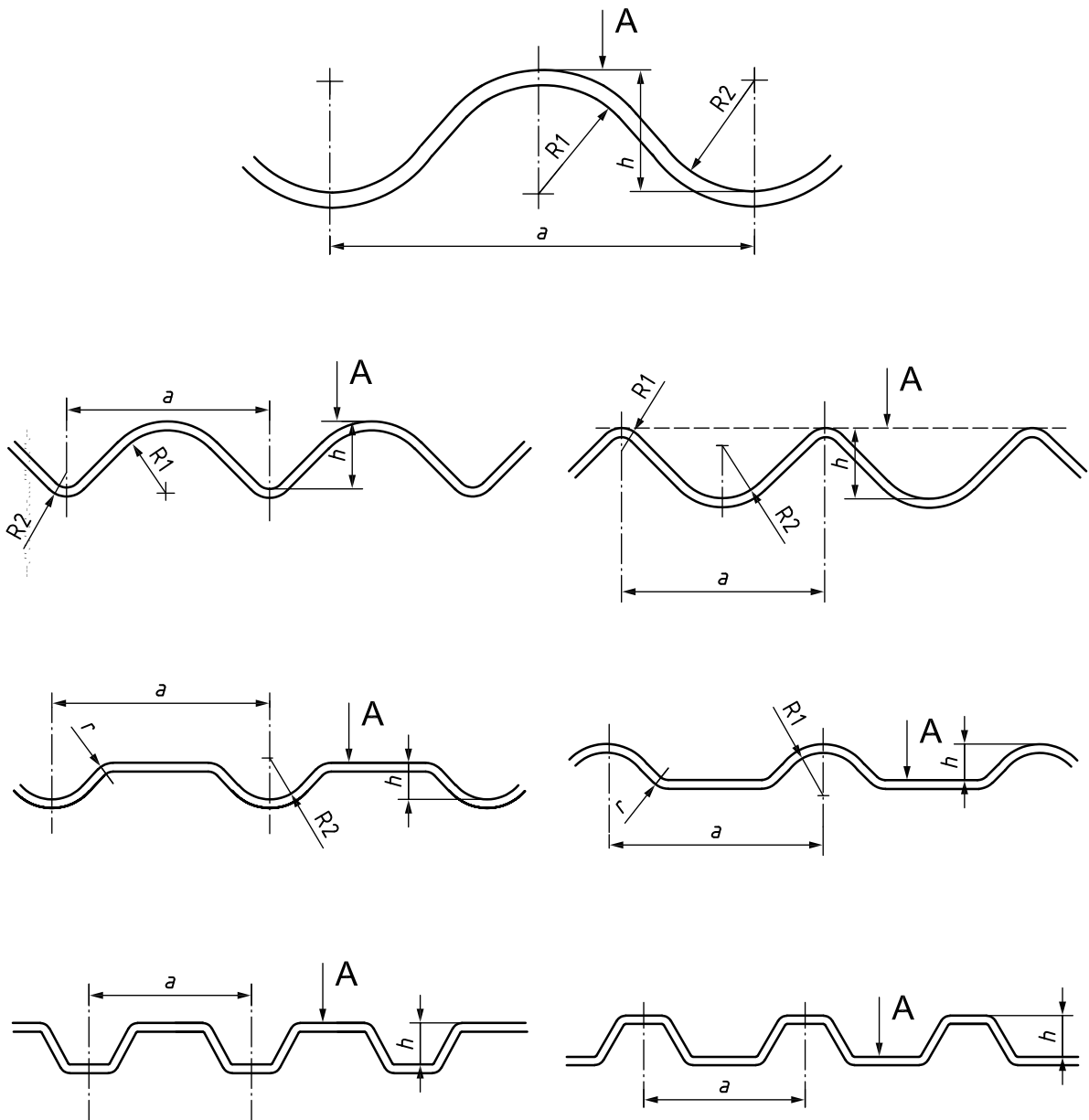

Key
 A upper face

Figure 1 — Examples of categorization by height of profile

3.2**side corrugation**

corrugation at the extreme end(s) of a cross section normally having a different pitch and height, normally used for side overlapping

3.3**acceptance test**

test to establish whether a batch of products conforms to a specification

NOTE 1 The test is performed on samples drawn from continuous production or from a consignment.

NOTE 2 Test methods, specifications and limit values are specified in this International Standard. Sampling levels and acceptance criteria are specified in 6.3.

NOTE 3 See ISO 390.

3.4**type test**

test performed to demonstrate conformity with the requirements of this International Standard or for the approval of a new product and/or when a fundamental change is made in formulation and/or method of manufacture, the effects of which cannot be predicted on the basis of previous experience

NOTE The test is performed on the as-delivered product, but is not required for each production batch.

3.5**acceptable quality level****AQL**

maximum percent defective (or maximum number of defects per 100 units) that can be considered satisfactory as a long-term average quality level in a sampling plan

NOTE When a manufacturer's process satisfies a sampling scheme with an AQL of 4 %, this indicates that 96 % of the inspected product exceeds the specification. This type of specification provides the consumer with a clearly defined lower quality boundary; this does not occur if acceptance is based solely on the average value of the measured property. Examples of sampling schemes can be found in ISO 390, ISO 2859-1 and ISO 3951-1.

3.6**as delivered**

in the same condition as that in which the producer intends to supply the product after completing all aspects of the process, including maturing and, when appropriate, painting

3.7**reinforcement fibres**

organic or inorganic reinforcement fibres for the manufacture of fibre-cement profiled sheets and fittings complying with this International Standard

NOTE See 5.1.

3.8**apparent density**

dry mass per unit volume based upon the volume of the sample calculated by water displacement or equivalent

NOTE This is an average density of the material and pores, coated or uncoated (as delivered).

3.9**breaking load**

maximum load achieved during the bending test and representing the load-bearing capacity of the sheets at the test span

3.10

bending moment at rupture

moment at mid-span calculated from the maximum load during the bending test

3.11

short sheet

sheet with a length less than or equal to 0,9 m

3.12

long sheet

sheet with a length greater than 0,9 m

3.13

upper face

face normally exposed to the weather

3.14

under face

reverse of the upper face

3.15

ambient laboratory conditions

atmosphere for testing or storing and conditioning of samples, defined for the purpose of this International Standard as a temperature of 23 °C ± 10 °C and a relative humidity of 50 % ± 20 %

3.16

fitting

components with particular shapes that are fitted to profiled sheets and complete, for instance, the roofing at the verge, ridge and eaves, or perform functions such as ventilation, daylight-admission, etc.

3.17

bending modulus

modulus of elasticity derived from the load-deflection data recorded during the breaking load test

4 Symbols, abbreviations and units

For the purposes of this document, the following symbols and abbreviations are used.

<i>a</i>	pitch of the corrugation, expressed in millimetres
<i>b</i>	dimension of the specimen parallel to the supports in either the breaking load test (called width of the specimen) or the bending moment test (called length of the specimen), expressed in millimetres
<i>e</i>	thickness of the sheet, expressed in millimetres
E_m	bending modulus, expressed in newtons per square millimetre, in the breaking load test
$f_{0,15}$	deflection, expressed in millimetres, at approximately 15 % of the maximum load in the breaking load test
$f_{0,55}$	deflection, expressed in millimetres, at approximately 55 % of the maximum load in the breaking load test
<i>F</i>	load at rupture in the breaking load test or bending moment test, expressed in newtons
F_s	load at rupture per metre width from the breaking load test, expressed in newtons per metre
$F_{0,15}$	load, expressed in newtons, at 15 % of the maximum load in the breaking load test

$F_{0,55}$	load, expressed in newtons, at 55 % of the maximum load in the breaking load test
h	height of the corrugation, expressed in millimetres
h_{od}	height of the edge of the descending corrugation, expressed in millimetres
h_{om}	height of the edge of the ascending corrugation, expressed in millimetres
I	moment of inertia of the section around a horizontal axis through the centre of gravity, expressed in millimetres
l	length of the sheet, expressed in millimetres
l_s	clear span between the supports in the breaking load test or the bending moment test, expressed in millimetres
L_1	upper estimation at 95 % confidence level of the result X_1
L_2	lower estimation at 95 % confidence level of the result X_2
m	mass of the specimen, expressed in grams, after drying, when determining the apparent density
M	bending moment at rupture per metre length from the bending moment test, expressed in newton-metres per metre
R_L	ratio of the estimation L_2 to the estimation L_1
s_1	standard deviation of the specimens with average X_1
s_2	standard deviation of the specimens with average X_2
V	apparent volume, expressed in cubic centimetres, of the specimens for the apparent density test
w	width of the sheet, expressed in millimetres
x_0	actual result obtained when dry-testing
\bar{X}_1	mean value of the bending test results of the control specimens (the first lot) for a type test
\bar{X}_2	mean value of the bending test results of the specimens (the second lot) after a type-test exposure
x_{std}	minimum value for use as the specification for the dry method of test; this value is calculated at the 97,5 % lower confidence level from the value y_{std} specified for the wet method of test in this International Standard
y_0	value calculated from the value obtained from a specimen tested dry, which is the estimate at the 97,5 % lower confidence level of the value expected from a specimen tested wet
y_{std}	minimum value specified in this International Standard for wet testing
α	one of the coefficients of the regression line defined in Annex E
β	one of the coefficients of the regression line defined in Annex E
ρ	apparent density of specimen, expressed in grams per cubic centimetre

5 Product requirements

5.1 General

5.1.1 Composition

5.1.1.1 Fibre-cement profiled sheets and fittings shall consist essentially of cement or a calcium silicate formed by the chemical reaction of a siliceous and a calcareous material, reinforced by fibres. The cement shall comply with the relevant national standards in the country of manufacture.

Process aids, fillers, aggregates and pigments that are compatible with the fibre-reinforced cement may be added.

5.1.1.2 Reinforcement may be one or a combination of the following materials:

- cellulose fibre;
- synthetic organic and/or inorganic fibre;
- glass fibre.

5.1.1.3 These materials may have one or more of the following forms:

- discrete elements randomly dispersed;
- continuous strands or tapes;
- nets or webs.

5.1.2 Manufacture

Fibre-cement profiled sheets may be formed either with or without pressure and cured either under natural or accelerated conditions, to meet the specified requirements. The fibre-cement fittings may be formed by either hand- or machine-moulding techniques.

5.1.3 Appearance and finish

The profiled sheets may be left with their natural color, or coloring matter may be added in the composition. They may also receive adherent colored or uncolored coatings or impregnations on their surfaces. The upper face shall have a generally smooth finish. Variations of the surface appearance that do not impair the characteristics of the sheets as defined in this International Standard are permitted.

Edges shall be straight and clean and the sheets shall be square. Sheets may have one or more corners pre-mitred or prepared for mitring and/or may be pre-drilled for fixing.

The fittings shall have a general appearance and finish compatible with the sheets with which they are being used.

5.2 Categorization and classification

5.2.1 According to nominal height of corrugations

The fibre-cement profiled sheets are divided into five categories depending on the nominal height, h , expressed in millimetres, of their corrugations, in accordance with Table 1. Examples of profiles are shown in Figure 1.

Table 1 — Categories of fibre-cement profiled sheets

Category	Height h mm	
	Long sheets length > 0,9 m	Short sheets length ≤ 0,9 m
A	$15 \leq h \leq 30$	$15 \leq h \leq 30$
B	$25 \leq h \leq 45$	$25 \leq h \leq 45$
C	$40 \leq h \leq 80$	$40 \leq h \leq 80$
D	$60 \leq h \leq 120$	$60 \leq h \leq 120$
E	$90 \leq h \leq 150$	—

5.2.2 According to thickness

The thickness of the sheets may be

- either approximately constant throughout the width of the profile (type A sheets); see Figure 2 a); or
- vary regularly between the valley and the crown for corrugated sheets or between the lower part and the upper part of ribs for asymmetrical section sheets, in the same cross-section (type B sheets); see Figure 2 b).

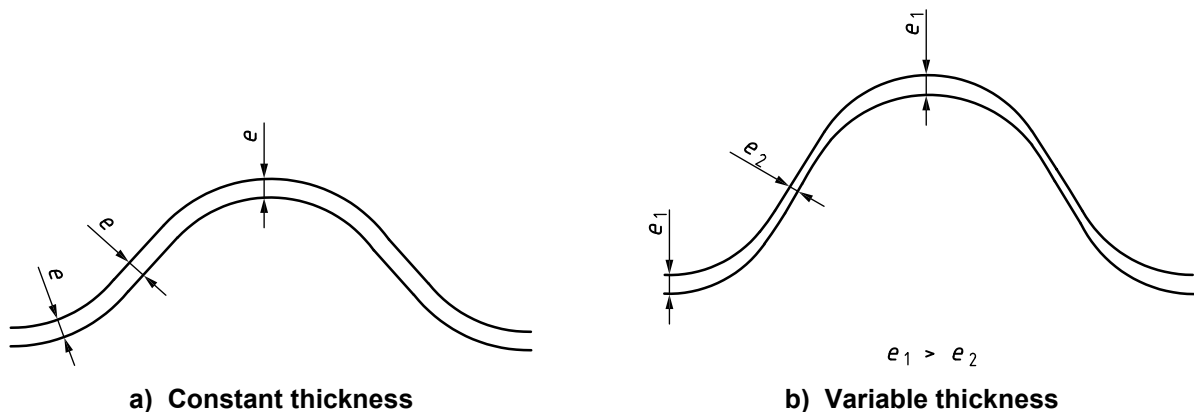

Figure 2 — Profiled sheet

5.2.3 According to minimum breaking load in bending for long sheets

For sheets with a length greater than 0,9 m (long sheets), each category of sheet is subdivided into classes according to the value of the minimum breaking load in bending; see Table 3.

5.2.4 According to minimum bending moment at rupture for long and short sheets

For long and short sheets, each category of sheet is subdivided into classes according to the value of the minimum bending moment at rupture; see Table 4.

National standards may choose one or more classes depending on the local conditions in the area of use.

National standards may specify, in addition of the minimum breaking load (in newtons per metre width), the unit flexural strength (in newtons per square millimetre) provided that the manufacturer defines the profile,

including the side corrugations, and consequently indicates how to calculate the moment of inertia for the specific corrugated surface section.

5.3 Dimensions and tolerances on nominal dimensions

5.3.1 General

The manufacturer shall specify the nominal dimensions, shapes and configuration of the edges of the fibre-cement profiled sheets.

Fittings shall have nominal dimensions and shapes determined by the manufacturer and appropriate to the corresponding fibre-cement profiled sheets with which the fittings are used.

5.3.2 Minimum thickness of profiled sheets

Each individual thickness measured according to B.5 shall be no less than the values in Table 2.

Table 2 — Minimum individual thickness of profiled sheets

Category	Height <i>h</i> mm	Minimum individual thickness <i>e</i> mm	
		Long sheets length > 0,9 m	Short sheets length ≤ 0,9 m
A	$15 \leq h \leq 30$	3,0	3,0
B	$25 \leq h \leq 45$	4,0	4,0
C	$40 \leq h \leq 80$	4,5	4,5
D	$60 \leq h \leq 120$	5,5	5,5
E	$90 \leq h \leq 150$	6,0	—

5.3.3 Number of corrugations

The number of corrugations considered for designation is the number of complete corrugations of the sheet.

5.3.4 Height of edges

The nominal height of edges of both the ascending and descending edges (see Figure 3) shall be specified in national standards. This requirement applies only for sheets having an ascending corrugation on one side and a descending corrugation on the other side.

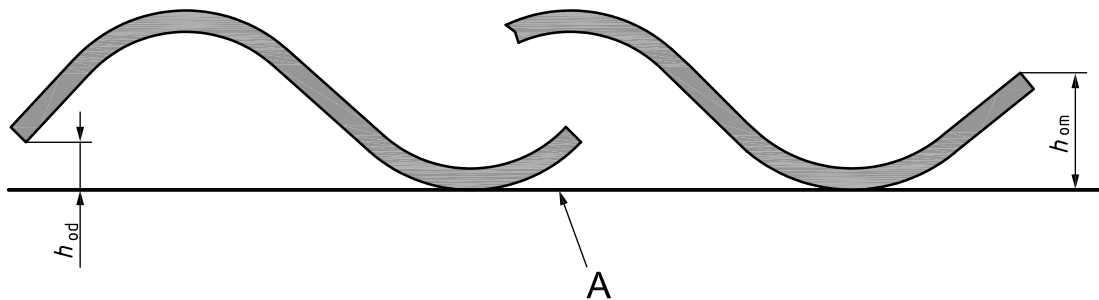

Key
A reference plane (control surface)

Figure 3 — Measurement of the height of edges

5.3.5 Tolerances on nominal dimensions for sheets

The following tolerances shall apply to nominal dimensions given by the manufacturer:

a) tolerance on pitch, a , expressed in millimetres:

$a \leq 75$	$\pm 1,5$
$75 < a \leq 180$	± 2
$180 < a \leq 260$	$\pm 2,5$
$260 < a$	± 3

b) tolerance on height of corrugation, h , expressed in millimetres:

$15 \leq h \leq 45$	± 2
$45 < h \leq 150$	± 3

c) tolerance on length: ± 10 mm;

d) tolerance on width: $\begin{matrix} +10 \\ -5 \end{matrix}$ mm;

e) tolerance on thickness, e : the average thickness shall be within ± 10 %, but no more than $\pm 0,6$ mm of the nominal thickness;

f) out-of-squareness of sheet: ≤ 6 mm;

g) tolerance on height of edges: applies only for sheets having an ascending (rising) edge on one side and a descending edge on the other side, and where it is required by the installation technique in order to ensure weather tightness and/or geometrical fit; the manufacturer shall use the tolerances specified in installation standards or regulations or, if none are given, he shall specify them in his literature.

5.3.6 Tolerances on nominal dimensions for fittings

The following tolerances shall apply to nominal dimensions given by the manufacturer:

a) tolerance on length: ± 10 mm;

b) tolerance on width: ± 10 mm;

c) tolerance on average thickness: ± 1 mm.

National standards may specify tolerances tighter than the ones specified in 5.3.5 and 5.3.6.

5.4 Physical requirements and characteristics

5.4.1 General

Mechanical and physical properties are normally determined on product as delivered. The results shall be identified as applying to coated or uncoated material. Failure of the coating does not constitute non-compliance of the product with this International Standard.

Testing of mechanical characteristics is performed with the upper face in compression. If required to establish a relationship between upper and under face testing, where significant differences are expected or if required for design purposes, the load shall be applied on the under face. Results obtained for under face testing are not relevant for classification.

5.4.2 Mechanical characteristics

5.4.2.1 General

For non-roofing and cladding applications, alternative mechanical characteristics may be agreed between the manufacturer and purchaser.

5.4.2.2 Minimum breaking load

When tested wet as specified in 7.3.2, using the method given in Annex C, long sheets shall have a minimum breaking load at least equal to the values specified in Table 3.

5.4.2.3 Bending modulus — Modulus of elasticity

The manufacturer's literature may specify the minimum bending modulus (modulus of elasticity) of the profiled sheets. When tested wet as specified in 7.3.2, using the method given in Annex C, the modulus of elasticity, E_m , between 15 % of the maximum load, $F_{0,15}$, and 55 % of the maximum load, $F_{0,55}$, in the breaking load test (see Figure C.2) shall not be less than the specified value.

Table 3 — Long sheets — Minimum breaking load per metre width

Category	Minimum breaking load (BL), wet, by class of long sheet (length > 0,9 m) N/m										
	BL1	BL2	BL3	BL4	BL5	BL6	BL7	BL8	BL9	BL10	BL11
A	600	1 250	1 400	—	—	—	—	—	—	—	—
B	—	1 250	1 400	2 000	2 500	3 500	—	—	—	—	—
C	—	—	1 400	2 000	2 500	3 500	4 250	—	—	—	—
D	—	—	—	—	—	3 500	4 250	5 500	7 000	—	—
E	—	—	—	—	—	—	—	—	—	8 500	12 500

5.4.2.4 Minimum bending moment

When tested wet as specified in 7.3.3, using the method given in Annex D, long sheets and short sheets shall have a minimum bending moment at rupture per metre length of sheet at least equal to the values specified in Table 4.

Table 4 — Long sheets and short sheets — Minimum bending moment per metre of length

Category	Minimum bending moment (BM), wet, by class of long sheet (length > 0,9 m) or short sheet (length ≤ 0,9 m) Nm/m						
	BM1	BM2	BM3	BM4	BM5	BM6	BM7
A	12 ^a	20	25	30	40	—	—
B	—	20	25	30	40	45	55
C	—	—	25	30	40	45	55
D	—	—	—	30	40	45	55
E	—	—	—	—	40	45	55

^a Applies to short sheets only.

5.4.3 Apparent density

The manufacturer's literature shall specify the minimum apparent density of the profiled sheets. When tested in accordance with 7.3.4, using the method given in Annex F, the density shall not be less than the specified value.

5.4.4 Water permeability

When tested for water permeability in accordance with 7.3.5, using the method given in Annex G, traces of moisture may appear on the underface of the specimen, but in no instance shall there be any formation of water drops.

NOTE Some national testing methods and performance requirements for the water permeability can differ from those given in this International Standard.

5.4.5 Freeze-thaw performance

5.4.5.1 Long and short sheets

This test shall be carried out if local climatic conditions justify it or national standards specify it.

When freeze-thaw testing is required, profiled sheets are tested in accordance with 7.3.6, using the test method given in Annex H. The ratio, R_L , of the lower versus the upper estimate mean values of the bending moments for the exposed and unexposed specimens, determined at the 95 % confidence level after 100 freeze-thaw cycles, shall not be less than 0,70.

Any visible cracks, delamination or other visible alteration shall not be of such a degree as to affect the performance in use.

5.4.5.2 Fittings

This test shall be carried out if local climatic conditions justify it or national standards specify it.

When freeze-thaw testing is required, fittings are tested in accordance with 7.3.7, using the test method given in Annex H. Any visible cracks, delamination or other visible alteration after 100 freeze-thaw cycles shall not be of such a degree as to affect the performance in use.

5.4.6 Heat-rain performance

When tested in accordance with 7.3.8, using the test method given in Annex I, after 50 heat-rain cycles, any visible cracks, delamination or other defects in the sheets shall not be of such a degree as to affect their performance in use. In case of doubt, a water-permeability test shall be performed on the sheet considered to have the highest incidence of defects after heat-rain exposure. When a product has successfully passed this water-permeability test, it shall be considered to comply with the requirement of heat-rain performance .

5.4.7 Warm water performance

When tested in accordance with 7.3.9 or 7.3.10, using the test method given in Annex J, the ratio, R_L , of the lower versus the upper estimate mean values of the breaking load (for long sheets) or the bending moment (for short sheets) for the exposed and unexposed specimens, determined at the 95 % confidence level after 56 d at 60 °C, shall not be less than 0,70.

5.4.8 Soak-dry performance

When tested in accordance with 7.3.11 or 7.3.12, using the test method given in Annex K, the ratio, R_L , of the lower versus the upper estimate mean values of the breaking load (for long sheets) or the bending moment (for short sheets) for the exposed and unexposed specimens, determined at the 95 % confidence level after 50 soak-dry cycles, shall not be less than 0,70.

5.5 Requirements concerning fire behavior

For the purpose of conformity with national regulations, products can be required to satisfy specific product or system fire tests. The details of the specifications and acceptance criteria shall be defined by national standards and/or regulations. Where no standard or performance requirement has been established, the product shall be tested in accordance with ISO 12468-1 and the results classified in accordance with ISO 12468-2.

5.6 Product performance

The categories and classes of fibre-cement profiled sheets defined in this International Standard might not be considered to give an indication of the service life of the product. Product service life is influenced by factors such as the geographical location, location of the product on the structure, type and method of installation and applied surface coatings. This International Standard defines only minimum physical performance requirements and does not prescribe material formulations. Therefore, it cannot be presumed that the service life of fibre-cement profiled sheets of similar category and class made by various manufacturers are similar. Service life can be estimated only for clearly specified product applications and products in defined climate zones.

5.7 Requirements concerning impact resistance

For the purpose of conformity with national regulations, roof assemblies may be required to satisfy specific requirements related to non-fragility in an effort to reduce the risk of people falling through roofs. The details of the test specifications and acceptance criteria shall be defined by national standards and/or regulations. In case information is required on the performance of the products used in the construction of such roof assemblies, fibre-cement profiled sheets shall be tested by soft-body impact in accordance with the test method in EN 15057.

6 Evaluation of conformity

6.1 General

The conformity of fibre-cement profiled sheets and fittings with the requirements of this International Standard shall be demonstrated by

- type testing, and
- quality control by the manufacturer.

6.2 Type testing

6.2.1 General

Type tests shall be performed on products as delivered. If the same composition and production method is used to produce sheets of various nominal sizes and thicknesses, it is necessary to perform type tests only on one size of each nominal thickness.

Table 5 lists the characteristics that shall be subject to type testing, with the minimum performance requirements and methods of test. All characteristics listed in Table 6 shall be subject to initial type testing.

6.2.2 Initial type testing

Initial type testing shall be performed to demonstrate conformity with this International Standard. Tests that have been carried out previously on a product having the same physical characteristics and satisfying similar conformity requirements and using the same test method and sampling procedure specified in this International Standard may be taken into account.

For initial type testing where production variance is not yet known, an estimate of the average characteristic at the 95 % confidence level shall be calculated.

Further type testing shall be carried out for the approval of a new product or where a fundamental change in formulation or method of manufacture creates effects that cannot be predicted on the basis of previous experience.

The results of all type tests shall be recorded and held by the manufacturer for at least five years.

6.2.3 Additional type testing

Whenever a change is made in the design of the fibre-cement profiled sheets, in the raw materials or in the production process that significantly changes one or more of the product characteristics, the type test shall be performed for the appropriate characteristic(s).

Table 5 — Type testing and property evaluation requirements

Physical property	Minimum test performance requirement	Test conditions	Reference for test method
Water permeability	5.4.4	7.3.5	Annex G
Freeze-thaw test	5.4.5	7.3.6 and 7.3.7	Annex H
Heat-rain test	5.4.6	7.3.8	Annex I
Warm water test	5.4.7	7.3.9 and 7.3.10	Annex J
Soak-dry test	5.4.8	7.3.11 and 7.3.12	Annex K

6.3 Quality control (QC) system

6.3.1 General

The manufacturer shall establish and maintain a documented QC system that ensures that the products placed into the market conform to the stated performance characteristics. The QC system shall consist of procedures, regular inspections and tests and/or assessments of the incoming materials, components, manufacturing equipment, manufacturing process and the product.

A manufacturer who establishes a quality management system in accordance with ISO 9001 is considered to meet the above requirements.

The results of inspections, tests or assessments that require action shall be recorded, together with the remedial actions taken.

Table 6 — Number of samples and compliance criteria

Characteristic	Reference for assessment method	Number of samples	Reference for compliance criteria
Dimensional conformity (sheets and fittings)	7.2.2 and Annex B	See 6.3.2.2	5.3.2 to 5.3.6
Breaking load and bending modulus	7.3.2 and Annex C	See 6.3.2.2	5.4.2.2, 5.4.2.3 and Table 3
Bending moment	7.3.3 and Annex D	See 6.3.2.2	5.4.2.4 and Table 4
Apparent density (sheets)	7.3.4 and Annex F	See 6.3.2.2	5.4.3
Water permeability	7.3.5 and Annex G	3 sheets	5.4.4
Freeze-thaw performance (sheets)	7.3.6 and Annex H	10 samples	5.4.5.1
Freeze-thaw performance (fittings)	7.3.7 and Annex H	5 samples	5.4.5.2
Heat-rain performance	7.3.8 and Annex I	4 samples	5.4.6
Warm water performance	7.3.9 or 7.3.10 and Annex J	10 samples	5.4.7
Soak-dry performance	7.3.11 or 7.3.12 and Annex K	10 samples	5.4.8

6.3.2 Acceptance tests

6.3.2.1 The specifications of acceptance tests apply to the product as delivered, but the tests may be carried out at an earlier stage of maturity.

When sampling from continuous production, testing of fibre-cement profiled sheets prior to coating and/or under conditions other than those in Table 7 is acceptable, provided that it has been statistically established (see Annex E) that compliance with the requirements in Table 5 is achieved.

Acceptance tests may also be used to confirm that a batch of profiled sheets conforms to this International Standard, e.g. in conjunction with type tests or for receiving inspection.

The tests include

- measurements of dimensions: length, width and thickness (method specified in Annex B);
- measurement of mechanical characteristics: breaking load, bending modulus and bending moment (methods specified in Annexes C and D);
- measurement of apparent density (method specified in Annex F);

Each limit of specification for the characteristics in Table 6 shall be subject to an AQL of 4 %.

6.3.2.2 Minimum sampling schemes shall be carried out as follows:

a) for fibre-cement profiled sheets:

- pitch: in accordance with ISO 2859-1;
- height of corrugations: inspection by attributes;
- height of edges, where applicable: double sampling;
- height of edges, where applicable: AQL 4 %;
- height of edges, where applicable: level S_1 ;
- breaking load and bending modulus: in accordance with ISO 3951-1;
- bending moment: inspection by variables, method σ or s ;
- apparent density: AQL 4 %, level S_3 .

b) for fibre-cement fittings:

- length and width: in accordance with ISO 2859-1, inspection by attributes, double sampling;
- thickness: AQL 4 %, level S_1 .

6.3.3 Equipment

All weighing, measuring and testing equipment shall be calibrated and regularly inspected according to documented procedures, frequencies and criteria.

6.3.4 Raw materials and components

The specification of all incoming raw materials and components shall be documented, as shall be the inspection scheme for ensuring conformity.

6.3.5 Product testing and evaluation

The manufacturer shall establish procedures to ensure that the stated values of all the characteristics are maintained.

6.3.6 Non-conforming products

Non-conforming products shall be separated and handled according to documented procedures.

6.4 Inspection of a consignment of finished products

Inspection of a consignment of finished products is not a requirement of this International Standard but if, in special cases, this is demanded by the customer, it may be conducted in accordance with Annex A and ISO 390.

7 Test requirements

7.1 General

Requirements for both acceptance and type testing are given in 7.2 and 7.3.

7.2 Dimensional and geometrical tests

7.2.1 General

The measurements shall be made on profiled sheets and fittings as delivered, using the apparatus and procedures given in Annex B.

7.2.2 Number and conditioning of specimens

The test shall be performed on whole (complete) sheets and fittings as delivered and without conditioning.

For type-testing, five sheets or fittings shall be taken; for acceptance testing and production control purposes, the minimum sampling scheme (6.3.2.2) is applied.

7.3 Physical performance tests

7.3.1 General

Details of the number, preparation and conditioning of specimens for different tests are given in 7.3.2 to 7.3.12. Details of the test method and the apparatus for each test are given in Annexes B to K.

7.3.2 Breaking load and bending modulus

NOTE See Annex C.

For type-testing, 10 specimens shall be taken; for acceptance testing and production control purposes, the minimum sampling scheme (see 6.3.2.2) is applied.

The test specimen shall be either a complete sheet (full length and width) or a transversely cut sheet (reduced length, full width) with a minimum length of 1,20 m. If specimens with full width cannot be tested, the width may be reduced by longitudinal cutting to a minimum of two complete corrugations, for sheet categories C, D and E, and a minimum of three complete corrugations for sheet categories A and B. To avoid the introduction of additional stress due to the longitudinal cutting, the width shall be slightly oversized, as shown in Figure 4.

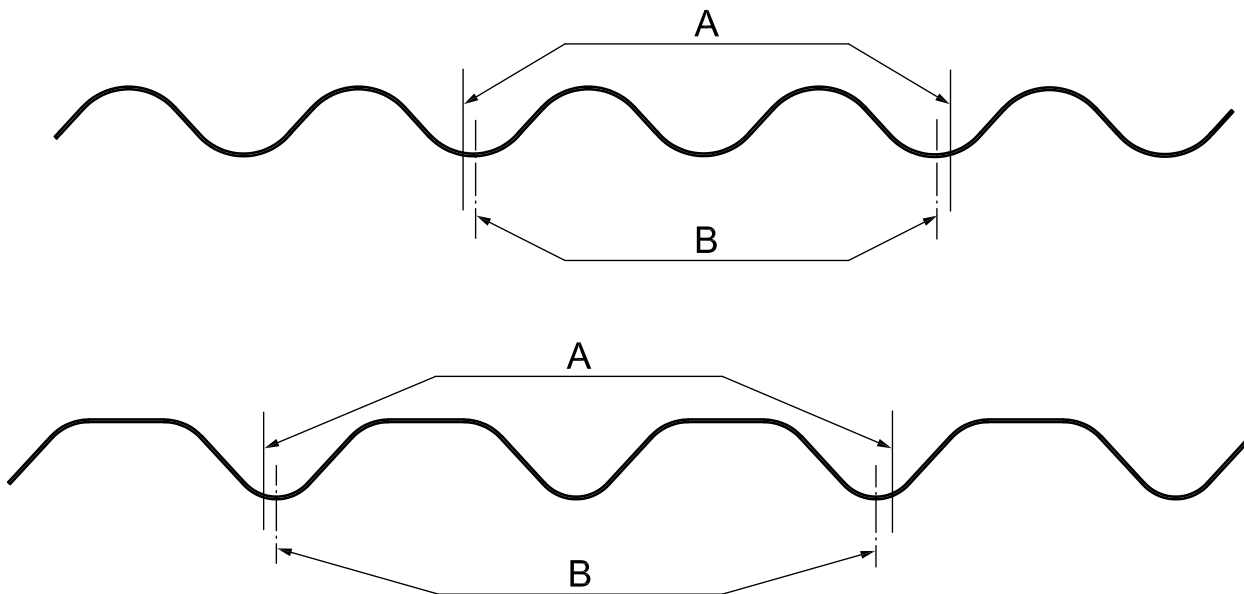

- Key**
 A trace of cutting
 B corrugation valley axis

Figure 4 — Longitudinal cutting of specimens

Testing shall be carried out after wet conditioning except that, for quality control purposes, dry testing can be carried out providing it is statistically established (see Annex E) that compliance with the requirements for wet testing given in Table 3 is ensured.

Prior to testing, specimens shall be conditioned in accordance with Table 7.

Table 7 — Conditioning

Test	Conditioning procedure
Acceptance test, wet	24 h immersion in water
Acceptance test, dry	7 d \pm 1 d in ambient laboratory conditions ^a
Type test	Prior to the bending test 7 d \pm 1 d in ambient laboratory conditions followed by 24 h immersion in water

^a For the purpose of this International Standard, ambient laboratory conditions (3.15) are a temperature of 23 °C \pm 10 °C and a relative humidity of (50 \pm 20) %.

7.3.3 Bending moment

NOTE See Annex D.

For type-testing, 10 specimens shall be taken; for acceptance testing and production control purposes, the minimum sampling scheme (see 6.3.2.2) is applied.

The test specimen shall be taken from a complete sheet by cutting it transversely to a length of at least 0,3 m but not more than 0,4 m and longitudinally, avoiding the edge corrugations, to a width as described below.

Specimens of sheets of constant thickness, as shown in Figure 2 a), should have a crown at the centre point and one full pitch either side plus an overlap on the support bearers to a maximum of half a pitch each side [see Figures 5 a) and 5 b)]. If the sheet width does not allow this, then reduce the sheet width to half of one pitch each side of the central crown plus an overlap as defined above [see Figure 5 c)].

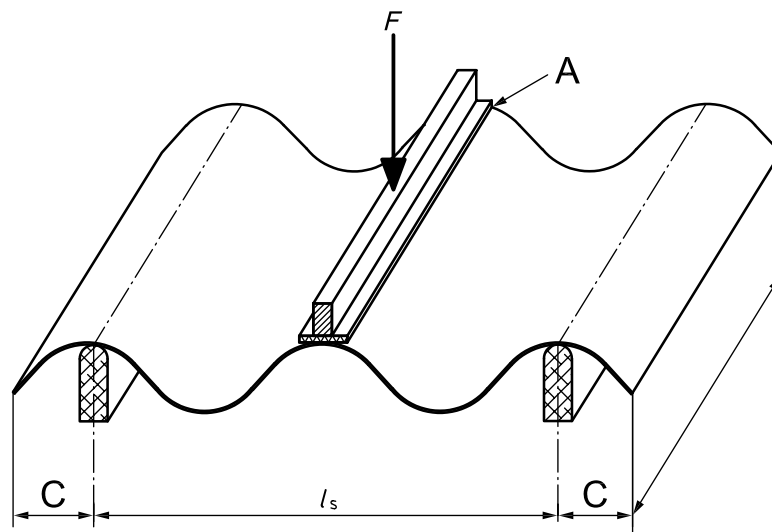

a)

Figure 5 (continued)

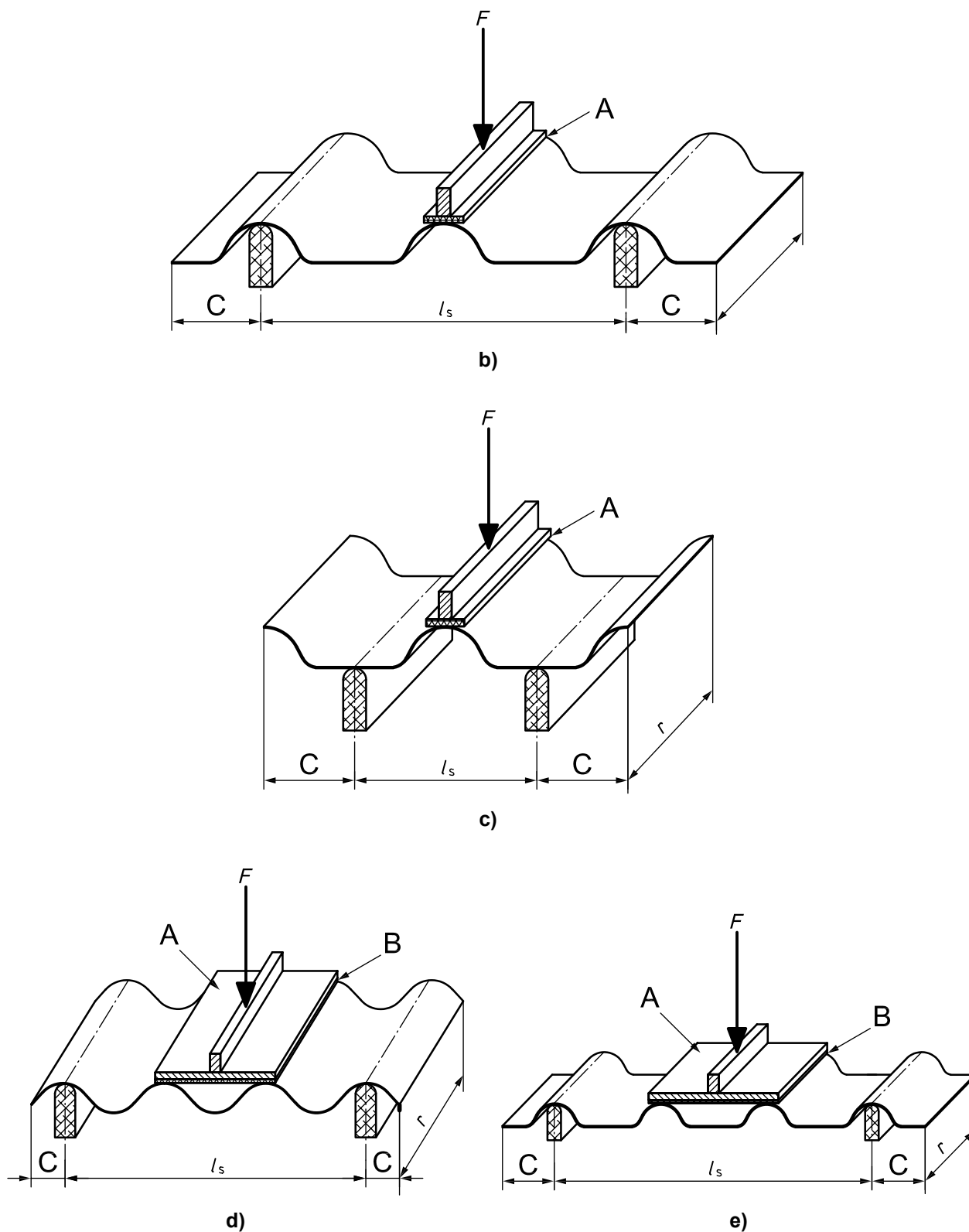

Key

- A rigid plate
- B 10 mm felt strip or smooth plate
- C 1/2 pitch max

Figure 5 — Apparatus for the bending moment test

It is recommended that sheets of variable thickness as shown in Figure 2 b) have a valley at the centre point and one and a half pitches either side plus an overlap on the support bearers to a maximum of half a pitch [see Figures 5 d) and 5e)].

Testing shall be carried out after wet conditioning except that, for quality control purposes, dry testing can be carried out providing it is statistically established (see Annex E) that compliance with the requirements for wet testing given in Table 4 is ensured.

Prior to testing, specimens shall be conditioned in accordance with Table 7.

7.3.4 Apparent density

NOTE See Annex F.

For type-testing, 10 specimens shall be taken; for acceptance testing and production control purposes, the minimum sampling scheme (see 6.3.2.2) is applied.

The test specimen shall be cut from a sheet to a length of at least 40 mm and a width of one full corrugation. Specimens are preferably taken from the specimens used for the bending test.

7.3.5 Water permeability

NOTE See Annex G.

Three sheets as delivered shall be tested.

The test shall be made on a whole (complete) sheet or a transversely cut sheet (reduced length, full width) with a minimum length of 1,20 m.

Prior to testing, the specimens shall be kept for $7 \text{ d} \pm 1 \text{ d}$ in ambient laboratory conditions.

7.3.6 Freeze-thaw test for long and short sheets

NOTE See Annex H.

In total, 20 specimens are required out of at least 10 different full-size, as-delivered sheets. Specimens shall be cut from the sheets, avoiding the edges, to a size conforming to the requirements for the bending moment test (see 7.3.3).

A first lot of 10 randomly selected specimens shall be conditioned as detailed in Table 7 and subjected to the bending moment test. The second lot, of the 10 remaining specimens, shall be immersed in water at ambient temperature ($> 5 \text{ }^\circ\text{C}$) for 48 h prior to freeze-thaw cycling. At the end of this period, the second lot of specimens is conditioned and subjected to the bending moment test in the same way as for the first lot.

7.3.7 Freeze-thaw test for fittings

NOTE See Annex H.

Out of five different, as-delivered fittings, five specimens are cut of at least $200 \text{ mm} \times 200 \text{ mm}$. However, full-size fittings may also be used. These specimens shall be immersed in water at ambient temperature ($> 5 \text{ }^\circ\text{C}$) for 48 h prior to freeze-thaw cycling. The freeze-thaw cycle is the same as for sheets.

7.3.8 Heat-rain test

NOTE See Annex I.

The number of sheets depends on the size of the frame on which the sheets are being mounted for exposure to the heat-rain cycles, taking into account the appropriate side and end overlaps as is common practice for

roofing. At least four full-size sheets or at least four sheets with their length reduced to not less than 1,20 m (in case of longer sheets) but of full width shall be tested.

The specimens shall be kept for $7 d \pm 1 d$ in ambient laboratory conditions prior to heat-rain cycling. Care shall be taken to separate the specimens to allow air circulation during this period of storage.

7.3.9 Warm water test for long sheets

NOTE See Annex J.

In total, 20 specimens are required out of at least 10 different full-size, as-delivered sheets. Specimens shall be cut longitudinally from the middle of a complete sheet to a width of two complete corrugations or, if the sheet is not wide enough, to a width of one complete corrugation. The longitudinal cutting shall be in the valley a little beyond the corrugation-valley axis as indicated in Figure 4. Specimens shall be cut transversely to a length allowing a clear span for the breaking load test of at least 12 times the height of the corrugation.

A first lot of 10 randomly selected specimens shall be conditioned as detailed in Table 7 and subjected to the breaking load test. The second lot, of the 10 remaining specimens, shall be submitted to warm-water exposure. At the end of this period, the second lot of specimens is further conditioned and subjected to the breaking load test in the same way as for the first lot.

7.3.10 Warm water test for short sheets

NOTE See Annex J.

In total, 20 specimens are required out of at least 10 different full-size, as-delivered sheets. Specimens shall be cut from the sheets, avoiding the edges, to a size conforming with the requirements for the bending moment test (see 7.3.3).

A first lot of 10 randomly selected specimens shall be conditioned as detailed in Table 7 and subjected to the bending moment test. The second lot, of the 10 remaining specimens, shall be submitted to warm-water exposure. At the end of this period, the second lot of specimens is further conditioned and subjected to the bending moment test in the same way as for the first lot.

7.3.11 Soak-dry test for long sheets

NOTE See Annex K.

In total, 20 specimens are required out of at least 10 different full-size, as-delivered sheets. Specimens shall be cut longitudinally from the middle of a complete sheet to a width of two complete corrugations or, if the sheet is not wide enough, to a width of one complete corrugation. The longitudinal cutting shall be in the valley a little beyond the corrugation-valley axis as indicated in Figure 4. Specimens shall be cut transversely to a length allowing a clear span for the breaking load test of at least 12 times the height of the corrugation.

A first lot of 10 randomly selected specimens shall be conditioned as detailed in Table 7 and subjected to the breaking load test. The second lot, of the 10 remaining specimens, shall be submitted to the soak-dry cycling. At the end of this period, the second lot of specimens is further conditioned and subjected to breaking load testing in the same way as for the first lot.

7.3.12 Soak-dry test for short sheets

NOTE See Annex K.

In total, 20 specimens are required out of at least 10 different full-size, as-delivered sheets. Specimens shall be cut from the sheets, avoiding the edges, to a size conforming with the requirements for the bending moment test (see 7.3.3).

A first lot of 10 randomly selected specimens shall be conditioned as detailed in Table 7 and subjected to the bending moment test. The second lot, of the 10 remaining specimens, shall be submitted to the soak-dry cycling. At the end of this period, the second lot of specimens is further conditioned and subjected to the bending moment test in the same way as for the first lot.

8 Marking

Product packaging and/or commercial documents accompanying the delivery shall contain the following information:

- a) trade mark or other means of manufacturer identification;
- b) the number of this International Standard;
- c) size and or name (for sheets only);
- d) product category and class (for sheets only);
- e) date of manufacture;
- f) NT, where required.

A minimum of 15 % of the profiled sheets in each delivered unit shall be durably marked with at least items a) and e) from the above list. Where required, the same amount of profiled sheets shall be marked with item f).

NT is the normal marking for fibre-cement products not containing asbestos. This marking should not be confused with the registered brand name, NT, in some countries.

Annex A (normative)

Consignment and inspection sampling

A.1 General

This annex gives details of a system for inspecting and sampling a consignment of finished products (see 6.4), that may, by agreement between the manufacturer and the purchaser, be included in a tender or product order.

NOTE Compliance with 6.4 is not a requirement of this International Standard

A.2 Sampling

A.2.1 When specified, the acceptance sampling shall be made on lot(s) of the consignment in accordance with the test programme of the relevant product standard, unless there is a special agreement. Table 6, therefore, specifies which characteristics are tested.

Details related to the application of this sampling subclause shall be agreed between the manufacturer and purchaser.

A.2.2 After agreement on the sampling procedure, sampling shall be carried out in the presence of both parties, from lot(s) that are being delivered to the purchaser. If the inspection lot(s) are not yet formed, the manufacturer should present to the purchaser the stock(s) from which the inspection lot(s) can be selected and marked. Unless otherwise agreed between manufacturer and purchaser, the maximum and minimum inspection lots shall be as follows:

- sheets of length less than 1,5 m: minimum 400 sheets and maximum 8 000 sheets;
- sheets of length 1,5 m and greater: minimum 200 sheets and maximum 3 000 sheets;
- fittings: minimum 200 fittings and maximum 400 fittings.

A.3 Testing

The tests shall be made in the laboratory of the manufacturer or by an independent laboratory selected by mutual agreement between the manufacturer and the purchaser. In case of dispute, the tests shall be performed in the presence of both parties.

A.4 Non-destructive tests

When non-destructive tests are performed and the result of the sampling inspection does not meet the acceptance requirements of this International Standard, the tests shall be required on each item of the consignment. The units of the consignment that do not meet the requirements when tested individually may be refused and disposed of, unless otherwise agreed between manufacturer and purchaser.

Annex B (normative)

Dimensional and geometrical testing procedures

B.1 General

This annex gives the details of the measuring apparatus and procedures that can be used for carrying out dimensional and geometrical measurements and the determination of compliance with the requirements of this International Standard.

B.2 Principle

Profiled sheets are measured to determine compliance with the requirements of this International Standard for pitch, height of corrugation, length, width, thickness, out-of-squareness and height of edges.

Fittings are measured to determine compliance with the requirements of this International Standard for length, width and thickness.

B.3 Measurement of pitch and height of corrugation for sheets

B.3.1 Apparatus

B.3.1.1 Surface, smooth, flat, with dimensions appropriate to the dimensions of the sheets.

B.3.1.2 Bars, cylindrical, steel, 200 mm long, with conical points fitted at the axis on one end and with a diameter large enough to touch the flanks of the corrugations of the sheet.

B.3.1.3 Micrometer, with a hemispherical head accurate to 0,1 mm.

B.3.1.4 Ruler, metal, graduated, accurate to 0,5 mm.

B.3.2 Procedure for measuring the pitch, a

Lay the sheets flat and square on the surface (see Figure B.1), ensuring that the valley of every corrugation is in contact with it.

Dimensions in millimetres

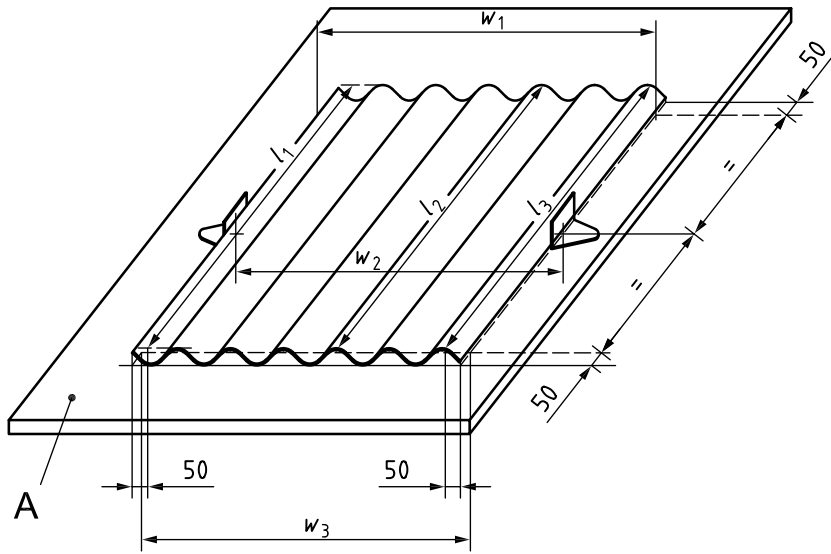

Key
 A surface (smooth, flat)

Figure B.1 — Measurement of the length and width

At one end of the sheet, lay the cylindrical bars in each valley of the corrugations, with the conical point extending slightly over the end of the sheet (see Figure B.2).

Measure with the ruler, to the nearest 0,5 mm, the distance between consecutive conical points.

Any other method of measurement with the same accuracy may be used.

Each measurement of the pitch shall be compared to the specification given in 5.3.5.

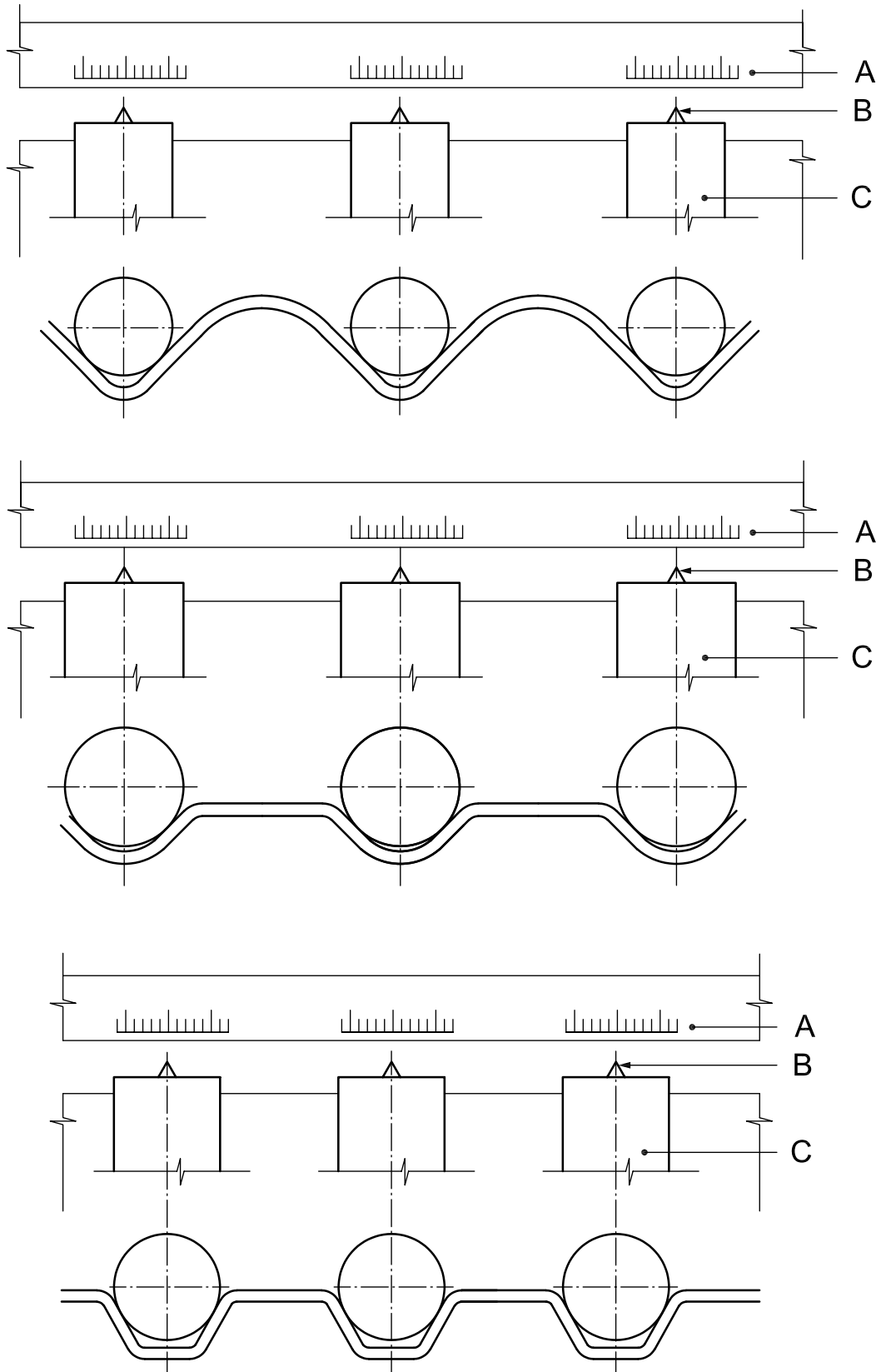

Key

- A graduated metal rule
- B conical point
- C cylindrical bar

Figure B.2 — Measurement of the pitch

B.3.3 Procedure for measuring the height of corrugation, h

Lay the sheets flat and square on the surface (see Figure B.1), ensuring that the valley of every corrugation is in contact with it.

Select three complete corrugations, or all complete corrugations if fewer than three, and on each selected corrugation take three regularly spaced measurements to the nearest 0,1 mm with the micrometer; see Figures B.3 a) and B.3 b)

Any other method of measurement with the same accuracy may be used.

Compare each result that is the average of three measurements on each corrugation to the specification given in 5.3.5.

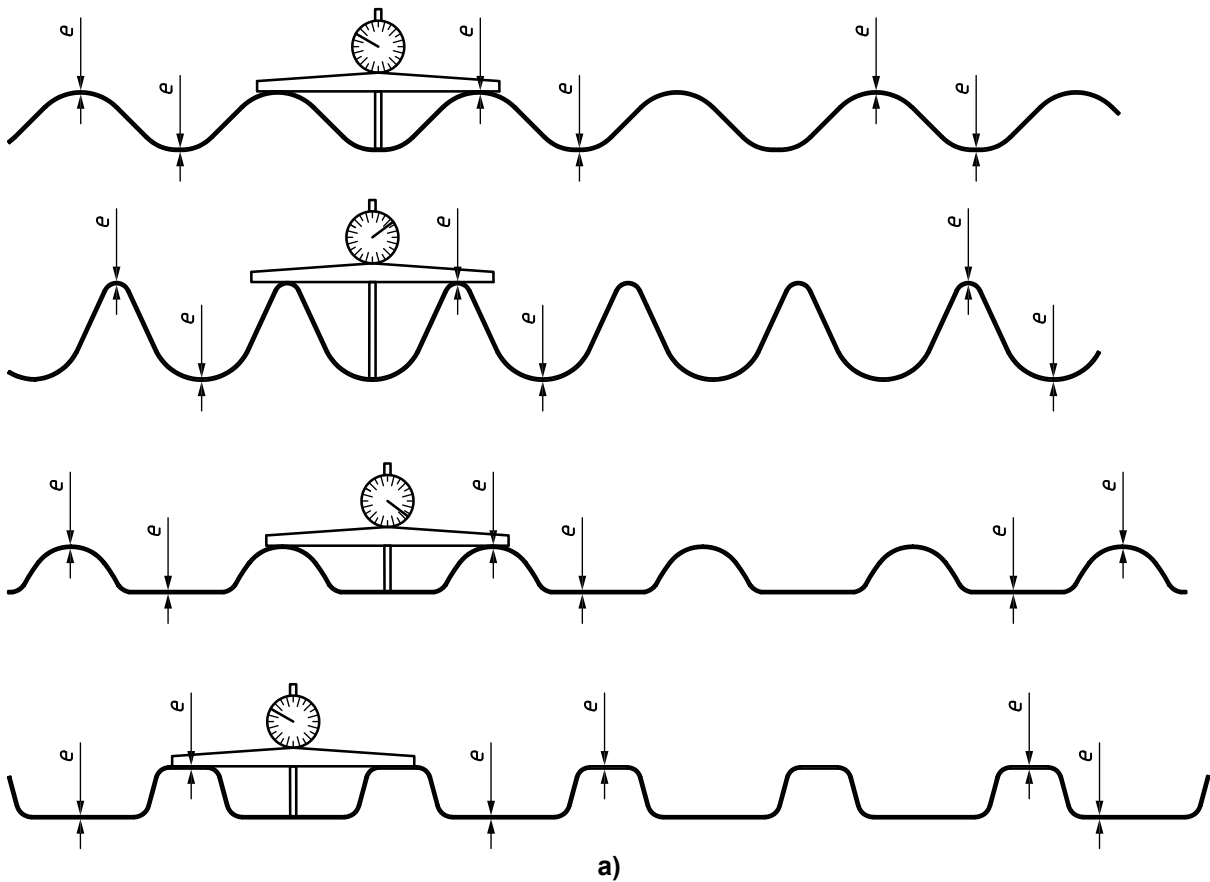

Figure B.3 (continued)

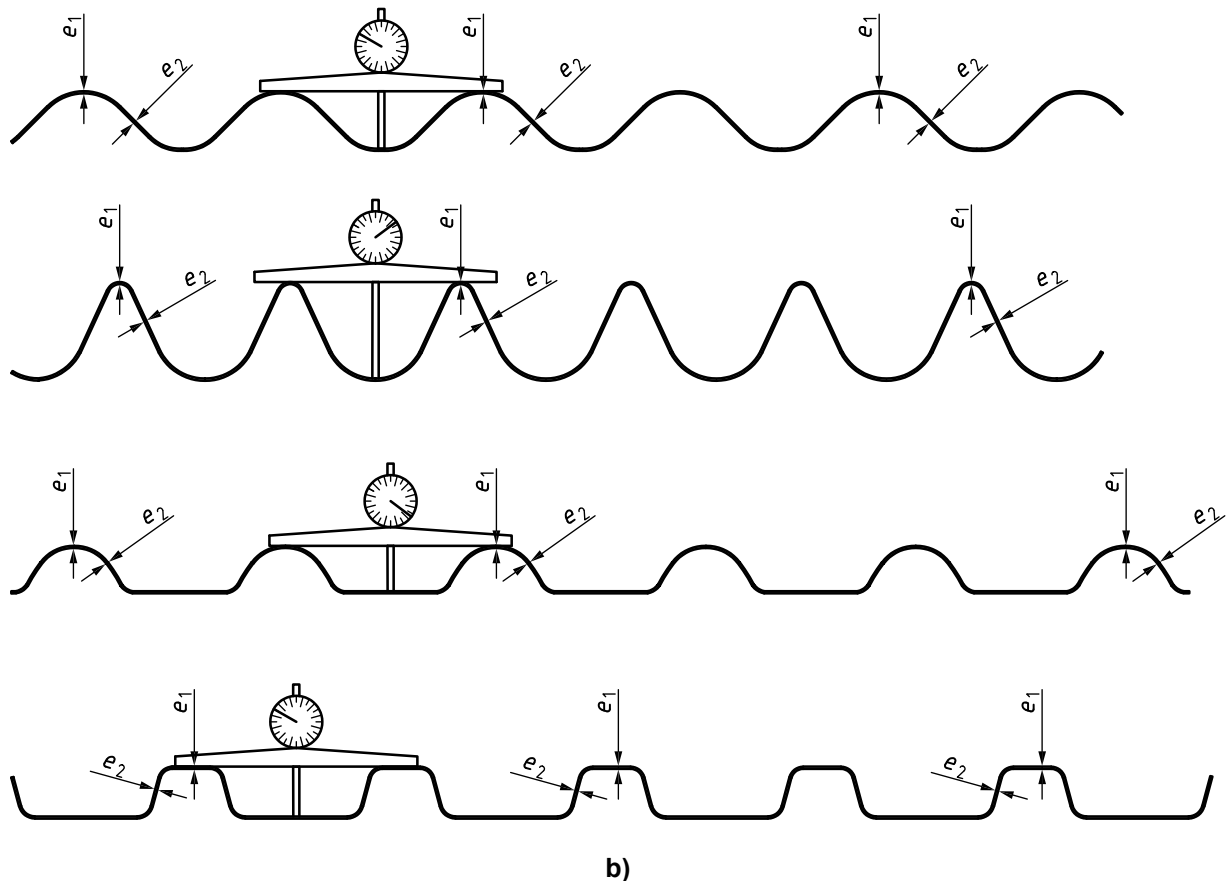

Figure B.3 — Measurement of the height of corrugations and thickness

B.4 Measurement of length and width of sheets

B.4.1 Apparatus

- B.4.1.1 Surface**, smooth, flat, with dimensions appropriate to the dimensions of the sheets.
- B.4.1.2 Ruler**, graduated in millimetres.
- B.4.1.3 Caliper blocks**, two, rectangular.

B.4.2 Procedure

Lay the sheet flat and square on the surface (see Figure B.1), ensuring that the valley of every corrugation is in contact with it.

To measure the length, take three measurements, one in the middle and one approximately 50 mm from each side, or further to avoid mitred corners; see Figure B.1.

To measure the width of sheets longer than 0,9 m, take three measurements, one in the middle and one approximately 50 mm from each end, or further if necessary to avoid mitred corners. For sheets of nominal length equal to or shorter than 0,9 m, take two measurements approximately 50 mm from each end; see Figure B.1.

Read each measurement to the nearest millimetre. Calculate the arithmetic average of the length and width and compare them with the specifications given in 5.3.5.

B.5 Measurement of the thickness of sheets

B.5.1 Apparatus

B.5.1.1 Micrometer, with hemi-cylindrical plates (see Figure B.4), accurate to 0,05 mm.

Dimensions in millimetres

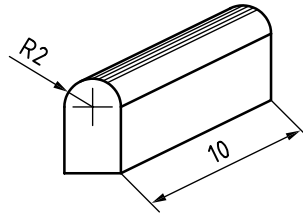

Figure B.4 — Hemi-cylindrical plate for measurement of thickness

B.5.2 Procedure

Take six measurements, to the nearest 0,1 mm, approximately 15 mm in from the end of each sheet as follows.

- For sheets of type A, take the measurements in three valleys and three crowns of the corrugation, as shown in Figure B.3 a).
- For sheets of type B, take the measurements on six sides of the corrugations, as shown in Figure B.3 b).

Each individual measurement shall be compared with the appropriate minimum thickness specified in Table 2 (see 5.3.2), and the arithmetic average of the six measurements made on one sheet shall be compared with the specifications given in 5.3.5.

B.6 Measurement of out-of-squareness of sheets

B.6.1 Apparatus

B.6.1.1 **Surface**, smooth, flat, with dimensions appropriate to the dimensions of the sheet.

B.6.1.2 **Ruler**, graduated, metal, accurate to 0,5 mm.

B.6.1.3 **Frame**, rectangular, with two corrugated ends and two straight sides or any other appropriate device to check the squareness of ends with respect to corrugations, with an accuracy of 1 mm.

B.6.2 Procedure

Lay the sheet flat and square on the surface, ensuring that the valley of every corrugation is in contact with it.

Measure the out-of-squareness at each end, as indicated in Figure B.5, for example.

Compare the results, expressed in millimetres, with the specification given in 5.3.5.

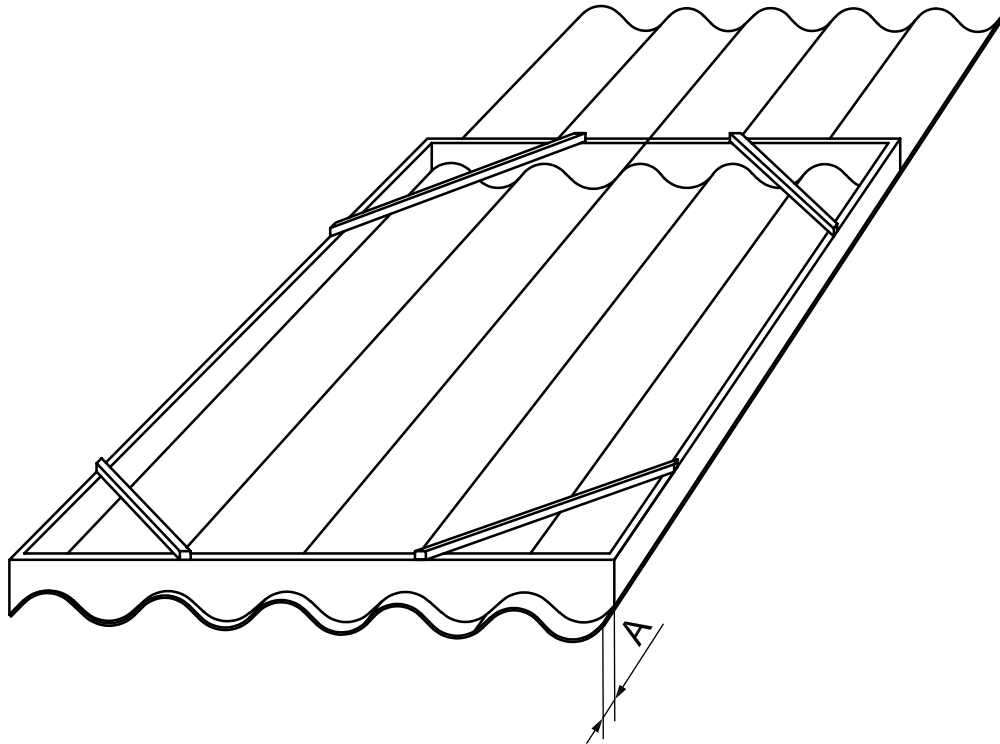
**Key**

A control area

Figure B.5 — Measurement of out-of-squareness**B.7 Measurement of the height of edges for sheets****B.7.1 Apparatus**

B.7.1.1 Surface, smooth, flat, with dimensions appropriate to the dimensions of the sheet.

B.7.1.2 Device, for measuring the height, h_{om} , of the ascending corrugation.

B.7.1.3 Device, for measuring the height, h_{od} , of the descending corrugation.

B.7.2 Procedure

Lay the sheet flat and square on the surface, ensuring that the valley of every corrugation is in contact with it.

Use the measuring devices to measure, to an accuracy of 1 mm, the height of both edges, as in Figure 3.

Compare the results, expressed in millimetres, at any point on the edges of the sheet with the specification given in 5.3.5.

B.8 Measurement of length and width for fittings**B.8.1 Apparatus**

The apparatus is the same as for sheets.

B.8.2 Procedure

For each dimension, take two measurements (one at each end). Read each measurement to the nearest millimetre.

Calculate the arithmetic average for each dimension and compare with the specification given in 5.3.6.

B.9 Measurement of thickness for fittings

B.9.1 Apparatus

The apparatus is the same as for sheets.

B.9.2 Procedure

Make the measurements

- on three crowns and three valleys on the corrugated parts, at approximately 15 mm from the edge, and
- on two distinct points on the flat part, at approximately 15 mm from the edge.

Calculate the average of the six measurements made on the corrugated part, and the average of the two measurements made on the flat part. Compare these two averages with the specification given in 5.3.6.

B.10 Test report

The test report shall contain the following information:

- a reference to this International Standard;
- all details necessary for complete identification of the batch of profiled sheets or fittings from which sample sheets or fittings are taken;
- nominal dimensions of the test sheets or fittings;
- test equipment details;
- test temperature and condition of the test pieces;
- measured values from the tests and conclusions as to compliance with the specifications;
- date of testing.

Annex C (normative)

Test method to determine the breaking load and the bending modulus of sheets

C.1 General

This annex gives a method of test for measuring the breaking load and calculating the bending modulus of fibre-cement profiled sheets and the procedures used for the determination of compliance with the requirements of this International Standard.

C.2 Principle

A profiled sheet or a specimen cut from a sheet is supported at two longitudinal ends and subjected at mid-span to a flexural bending load until failure occurs (three-point bending). The load/deflection relationship, as well as the failure load, is recorded.

C.3 Measurement of breaking load

C.3.1 Apparatus

C.3.1.1 Bending test machine, with a constant rate of deflection when applying the load (where this facility is not available, a constant rate of loading is acceptable), with an error of accuracy and an error of repeatability less than or equal to 3 %; see Figure C.1.

This machine is comprised of the following:

- two parallel supports (one fixed), set in the same horizontal plane and longer than the sample width; the upper surface of each support shall be flat and 50 mm wide; the distance between the supports shall be set to give a clear span of 1,1 m;
- a rigid, flat loading beam, 230 mm wide, of the same length as the supports and parallel and equidistant from them; it shall be attached to the mechanism by means of a flexible joint;
- three strips of felt or soft material approximately 10 mm thick.

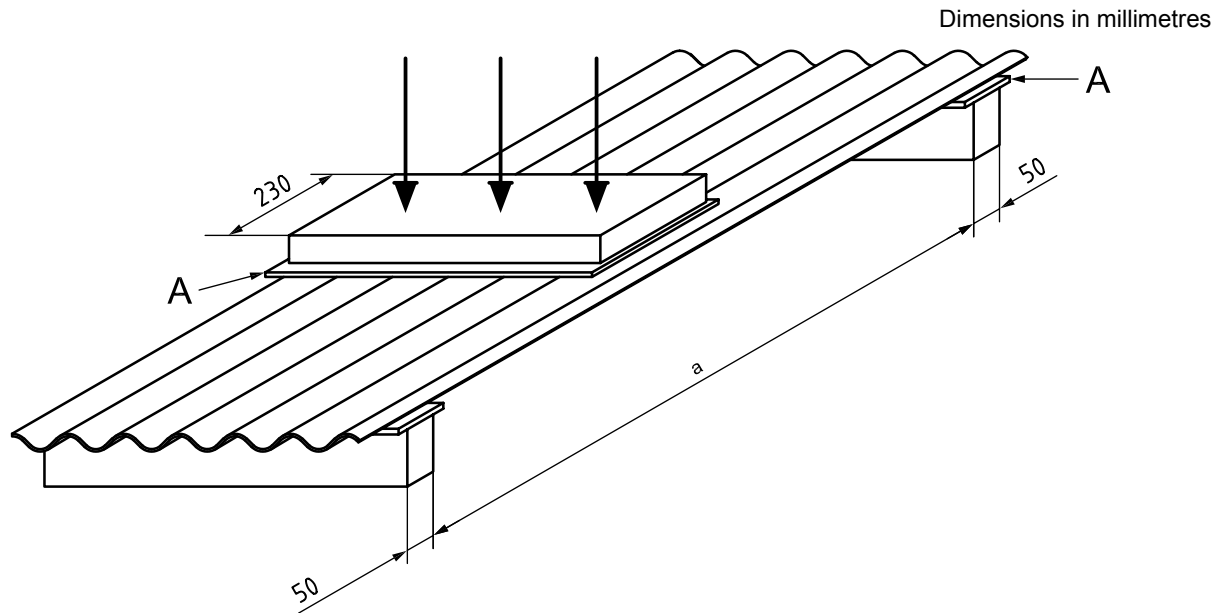

- Key**
- A strips of felt of soft material
 - a $l_s = 1\,100\text{ mm}$.

Figure C.1 — Breaking load test

C.3.2 Procedure

For sheets having a height of corrugation greater than 80 mm, increase the span to at least 15 times the height of the corrugation.

For sheets shorter than 1,2 m, reduce the clear span to a minimum of 700 mm or 12 times the height of the corrugations, whichever is greater, and reduce the width of the loading beam by the ratio of this clear span to 1,1 m.

Place the specimen on the supports (the upper face in compression), which are at right angles to the corrugations. After interposition of strips of felt or soft material, load the specimen at mid-span using the flat beam, distributing evenly the load applied on its centre.

Measure the deflection, expressed in millimetres, at mid-span (below the loading head) to an accuracy of 0,1 mm, and plot these values against the corresponding loads. If the deflection is determined by incremental readings, use at least six pairs of readings.

The rate of loading shall be such that the rupture occurs between 10 s and 45 s after the start of its application.

Record the load at rupture, i.e. maximum load, *F*.

C.3.3 Calculation of breaking load per metre of width

The breaking load per metre of width, F_s , expressed in newtons per metre, is given by Equation (C.1):

$$F_s = \frac{F}{b} \times 10^3 \tag{C.1}$$

where

F is the load at rupture, expressed in newtons;

b is the dimension of the specimen parallel to the supports, expressed in millimetres.

When a span length, l_s , other than 1 100 mm is used, the breaking load, F_s , per metre width for comparison with Table 3 is as given in Equation (C.2):

$$F_s = \frac{F}{b} \cdot \frac{l_s}{1100} \times 10^3 \quad (\text{C.2})$$

where l_s is the clear span between the supports, expressed in millimetres.

The results shall be compared with the appropriate specification given in Table 3 for the breaking load.

C.3.4 Calculation of bending modulus (modulus of elasticity)

The bending modulus, E_m , expressed in newtons per square millimetre, of each of the specimens is calculated as given in Equation (C.3):

$$E_m = \frac{(F_{0,55} - F_{0,15})(l_s)^3}{48I(f_{0,55} - f_{0,15})} \quad (\text{C.3})$$

where

l_s is the span, expressed in millimetres;

$F_{0,55} - F_{0,15}$ is the increment of load, expressed in newtons per metre, on the straight line portion of the load-deflection curve; see Figure C.2;

$f_{0,55} - f_{0,15}$ is the increment of deflection, expressed in millimetres, at the mid-span of the test specimen, corresponding to $F_{0,55} - F_{0,15}$;

I is the moment of inertia of the section around a horizontal axis through the center of gravity expressed in mm^4 ;

$F_{0,15}$ shall be approximately 15 % of the maximum load;

$F_{0,55}$ shall be approximately 55 % of the maximum load.

The bending modulus for each specimen shall be expressed to four significant figures.

The results shall be compared with the appropriate specification given in 5.4.2.3 for the bending modulus.

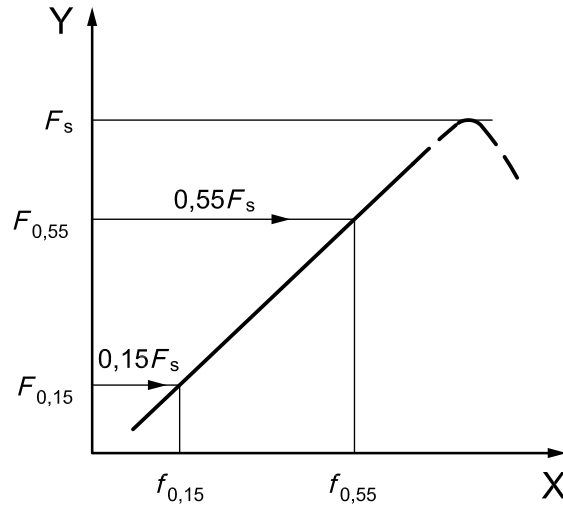

Key

- X deflection, expressed in millimetres
- Y load, expressed in newtons per metre

Figure C.2 — Measurement of deflection during breaking load test

C.4 Test report

The test report shall contain the following information:

- a reference to this International Standard;
- all details necessary for complete identification of the batch of profiled sheets from which sample sheets were taken;
- dimensions of the test specimen;
- test equipment details;
- test temperature and condition of the test pieces;
- measured and calculated values from the tests and conclusions as to compliance with the specifications;
- date of testing.

Annex D (normative)

Test method to determine the bending moment of a sheet

D.1 General

This annex gives a method of test for measuring the bending moment of fibre-cement profiled sheets and the procedures used for the determination of compliance with the requirements of this International Standard.

D.2 Principle

A specimen cut from a profiled sheet is supported at two ends and subjected at mid-span to a flexural bending load until failure occurs (three-point bending).

D.3 Measurement of bending moment

D.3.1 Apparatus

D.3.1.1 Bending test machine, with a constant rate of deflection when applying the load (where this facility is not available, a constant rate of loading is acceptable) and with an error of accuracy and an error of repeatability less than or equal to 3 %.

This machine is comprised of the following:

- two parallel supports (one fixed), set in the same horizontal plane and longer than the sample width; the face of each support shall be rounded to a radius of 3 mm to 25 mm;
- either a loading bar for sheets, as shown in Figure 5 a), 5 b) or 5 c), or a rigid loading beam of suitable width for sheets, as shown in Figures 5 d) and 5 e), longer than the sample length, parallel to the supports and located at the same distance of each of them; it shall be attached to the mechanism by means of a flexible joint;
- strip of felt or soft material approximately 10 mm thick, longer than the sample length and wider than the loading bar or the rigid beam.

D.3.2 Procedure

Place the specimens on the supports (the upper face in compression) and, after interposition of strips of felt or soft material [see Figures 5 a) to 5 e)], load in the middle at the top of a corrugation, using the loading bar or the rigid beam, depending on the type.

Adjust the rate of loading such that the rupture occurs between 10 s and 30 s after the start of its application.

Record the load at rupture, F .

D.3.3 Calculation of bending moment per metre length

The bending moment, M , at rupture per metre length, expressed in newton-metres per metre, is given by Equation (D.1) for sheets of constant thickness [see Figure 2 a)] and by Equation (D.2) for sheets of variable thickness [see Figure 2 b)]:

$$M = \frac{F \times l_s}{4 \times b} \quad (\text{D.1})$$

where

F is the load at rupture, expressed in newtons;

b is the width of the specimen, expressed in millimetres;

l_s is the span, expressed in millimetres;

$$M = \frac{F \times l_s}{6 \times b} \quad (\text{D.2})$$

The results shall be compared with the appropriate specification given in Table 4.

D.4 Test report

The test report shall contain the following information:

- a reference to this International Standard;
- all details necessary for complete identification of the batch of profiled sheets from which sample sheets were taken;
- dimensions of the test specimen;
- test equipment details;
- test temperature and condition of the test pieces;
- measured and calculated values from the tests and conclusions as to compliance with the specifications;
- date of testing.

Annex E (normative)

Statistical method for determining the corresponding wet values or revised dry specifications for the breaking load and/or bending moment when carrying out the dry method of test or when testing prior to coating for quality control purposes

E.1 Procedure

Sample at least 20 sheets. Cut them into paired specimens for either the breaking load test described in Annex C or the bending moment test described in Annex D.

Cut both specimens of a pair from the same sheet and give each the same number.

Test one set of specimens wet and one set of specimens dry for breaking load or bending moment.

From the paired results, determine whether there is a correlation between them at a 97,5 % confidence level, using the method in E.2.

If there is no significant correlation, then dry testing cannot be used. If the correlation is positive, then continue as follows.

- a) Determine the regression line, using the method described in E.3.
- b) Determine either of the following:
 - a wet value for each specimen from the obtained dry value, using the method described in E.4;
 - a revised minimum value for use as the specification for dry testing corresponding to the appropriate minimum value for wet testing as specified in this International Standard, using the method described in E.5.

E.2 Determination of the correlation between the results of testing wet and dry specimens

Calculate the coefficient of correlation between wet and dry values using Equation (E.1):

$$r = \frac{\sum_{i=1}^n (x_i - \bar{x})(y_i - \bar{y})}{\left[\sum_{i=1}^n (x_i - \bar{x})^2 \sum_{i=1}^n (y_i - \bar{y})^2 \right]^{1/2}} \quad (\text{E.1})$$

where

- n is the number of paired specimens;
- x_i is the individual value of the i th specimen tested dry;
- y_i is the individual value of the i th specimen tested wet;

\bar{x} is the mean value of x_i for $i = 1$ to n ;

\bar{y} is the mean value of y_i for $i = 1$ to n .

Calculate the value of the statistical parameter, t , from Equation (E.2):

$$t = \left| \frac{r}{\sqrt{1-r^2}} \right| \sqrt{n-2} \quad (\text{E.2})$$

Compare t to the Student's coefficient, $t_{0,025/n-2}$:

— If $n = 20$, then $t_{0,025/n-2} = 2,101$.

— For $n > 20$, refer to Student's t tables.

If $t > t_{0,025/(n-2)}$, there is a significant relationship between the results of wet and dry testing and the regression line is straight. Dry testing can be carried out for quality-control purposes.

E.3 Determination of the regression line

The equation of the regression line is given in Equation (E.3):

$$y = \alpha + \beta x \quad (\text{E.3})$$

Calculate the values of β and α from Equations (E.4) and (E.5), respectively:

$$\beta = \frac{\sum_{i=1}^n (x_i - \bar{x})(y_i - \bar{y})}{\sum_{i=1}^n (x_i - \bar{x})^2} \quad (\text{E.4})$$

$$\alpha = \bar{y} - \beta \bar{x} \quad (\text{E.5})$$

A plot of the regression line is shown in Figure E.1.

E.4 Determination of a value for wet testing from an obtained value for dry testing

Calculate the residual standard deviation, s , also called the standard error of the estimate, from Equation (E.6):

$$s = \sqrt{\frac{\sum_{i=1}^n (y_i - \alpha - \beta x_i)^2}{(n-2)}} \quad (\text{E.6})$$

Calculate the value for wet testing from Equation (E.7) using the obtained dry value, x_0 :

$$y_0 = (\alpha + \beta x_0) - st_{0,025/n-2} \sqrt{\frac{n+1}{n} + \frac{(x_0 - \bar{x})^2}{\sum_{i=1}^n (x_i - \bar{x})^2}} \quad (\text{E.7})$$

where

x_o is the actual result obtained when dry testing;

y_o is the value calculated from x_o , which is the estimate at the lower 97,5 % confidence level of the value expected from wet testing.

— If $n = 20$, then $t_{0,025/n-2} = 2,101$.

— For $n > 20$, refer to Student's t tables.

For routine quality control testing, individual values of y_o can be calculated each time or, alternatively, a suitable range of values for x_o can be substituted into Equation (E.7) to construct a plot of x_o vs y_o (see Figure E.1) from which future values can be read.

E.5 Determination of the minimum value specified for dry testing, x_{std} , corresponding to the minimum value specified for wet testing in this International Standard, y_{std}

Plot the line for x_o vs y_o by substituting a suitable range of values for x_o into Equation (E.7).

Read the value for x_{std} corresponding to the value for y_{std} from the graph, as shown in Figure E.1.

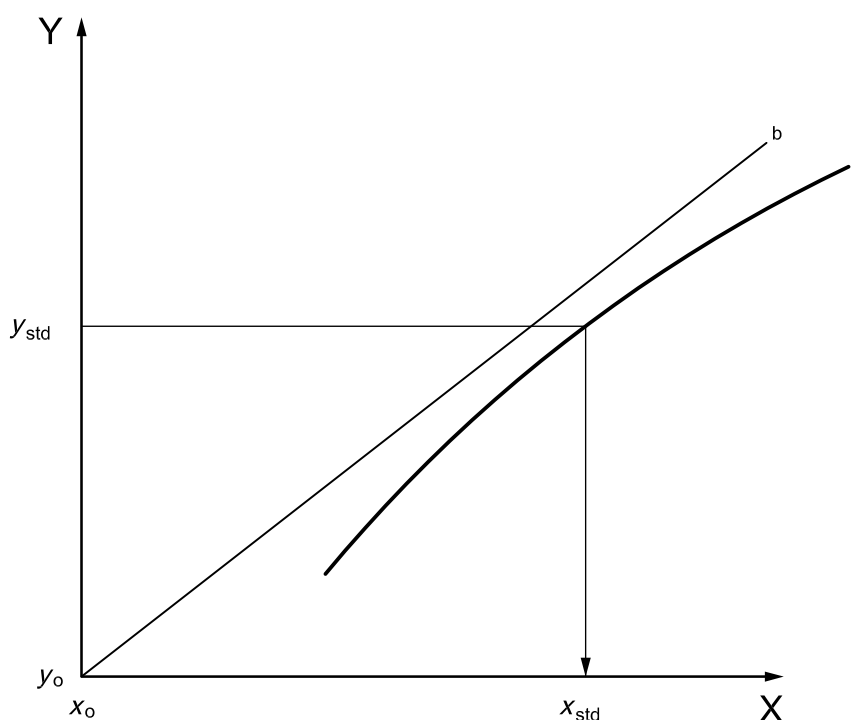

Key

X dry values, x_o

Y wet values, y_o

y_{std} minimum value specified in this International Standard for wet testing

x_{std} minimum value specified for dry testing, calculated from y_{std} at the 97,5 % lower confidence level

a Values from Equation (E.7).

b Regression line.

Figure E.1 — Regression line for wet/dry values with lower confidence level

Annex F (normative)

Test method to determine the apparent density

F.1 General

This annex gives the test method for determination of the apparent density (see 7.3.4) of fibre-cement profiled sheets. This is the average density of the material and its pores.

F.2 Principle

The volume of a saturated specimen is determined by immersion in water. The specimen's oven-dry mass is then measured. The apparent density is determined by calculation from the measured values.

F.3 Apparatus

F.3.1 Oven, ventilated, capable of achieving a temperature of $100\text{ °C} \pm 5\text{ °C}$ with a full load of specimens.

F.3.2 Balance, accurate to within 0,1 % of the specimen mass, equipped to determine both the immersed mass and the non-immersed mass of the specimen.

F.4 Test procedure

Immerse specimen in water for at least 24 h.

Take saturated specimen, remove excess water from surfaces and then determine the volume, V , of the water displaced by the saturated specimen when placed into a water bath. Record this value. Any other method having an equivalent accuracy may be used.

Remove specimen from water bath and place it into a ventilated oven that is maintained at a temperature of $100\text{ °C} \pm 5\text{ °C}$ until the specimen has reached constant mass, determined as a difference between successive weighings of less than 0,1 % in any 24 h period. Record this value as m .

F.5 Calculation of apparent density

The apparent density, ρ , expressed in grams per cubic centimetre, is given by Equation (F.1):

$$\rho = \frac{m}{V} \quad (\text{F.1})$$

where

m is the mass, expressed in grams, of the test piece after drying;

V is the volume of the specimen, in cubic centimetres.

F.6 Test report

The test report shall contain the following information:

- a reference to this International Standard;
- all details necessary for complete identification of the batch of profiled sheets from which sample sheets were taken;
- dimensions of the test specimen;
- test equipment details;
- test temperature and condition of the test pieces;
- measured displacement and mass of the specimen;
- calculated value of the apparent density;
- date of testing.

Annex G (normative)

Test method to determine the water permeability of a sheet

G.1 General

This annex gives details of the test procedure (see 7.3.5) and apparatus required to determine that fibre-cement profiled sheets comply with the water-permeability requirements of this International Standard.

G.2 Principle

A specified depth of water is applied to the upper face of a horizontally positioned specimen for a prescribed period of time. Visual examination of the test specimen determines compliance with the requirements of this International Standard.

G.3 Apparatus

G.3.1 Frame, constructed as shown in Figure G.1.

The width of the frame depends on the profile of the sheets and shall be, wherever possible, greater than 0,5 m. The length of the frame shall be between 0,5 m and 1,0 m.

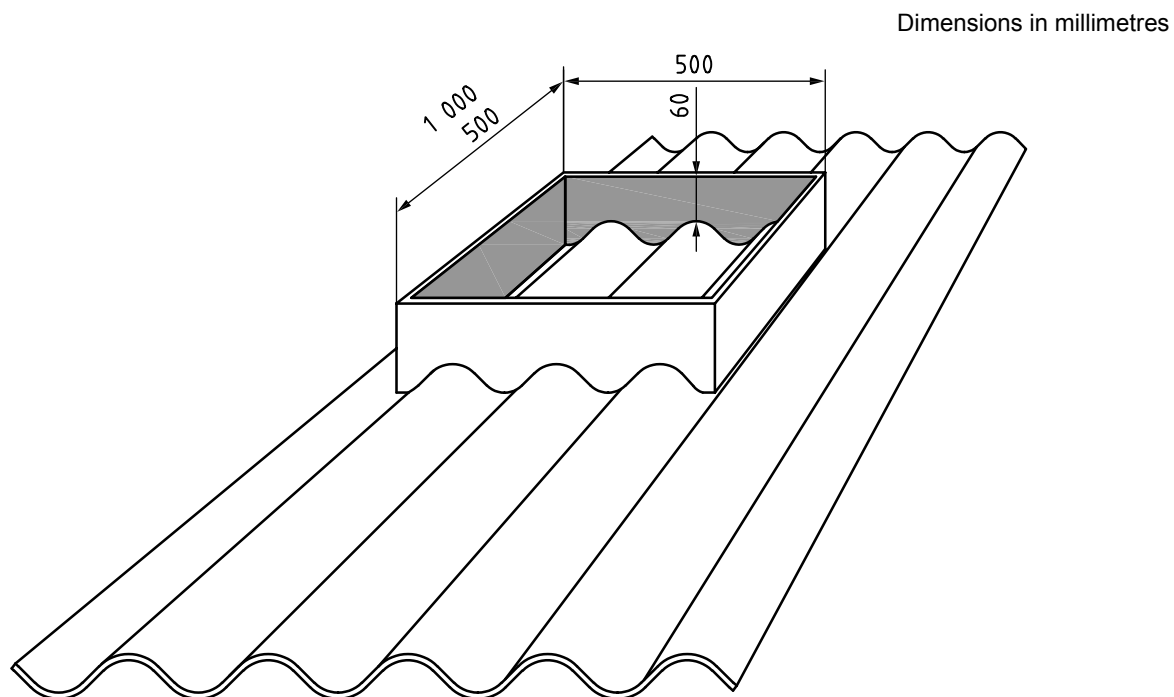

Figure G.1 — Arrangement for the water permeability test

G.4 Procedure

Seal the frame on the upper face of the specimen. Place the specimen horizontally, in normal laboratory conditions and above the ground, e.g. on supports, in such a way as to allow visual inspection of the under face without moving the specimen.

Fill the frame with water until the level is approximately 20 mm above the top of corrugations and maintain the level constant during the test.

After 24 h, examine the under face for the presence of water drops. Report the visual condition of the specimen.

Compare the result with the specification given in 5.4.4.

G.5 Test report

The test report shall contain the following information:

- a reference to this International Standard;
- all details necessary for complete identification of the batch of profiled sheets from which sample sheets were taken;
- dimensions of the test specimen;
- test equipment details;
- test temperature and condition of the test pieces;
- visual condition of the test specimens at the conclusion of the test;
- date of testing.

Annex H (normative)

Test method to determine the freeze-thaw performance of sheets and fittings

H.1 General

This annex gives the details of the apparatus and testing procedure required to evaluate the freeze-thaw performance of fibre-cement profiled sheets and fittings.

H.2 Principle

A lot of specimens is saturated by immersion in water and subjected to a number of cycles comprised of a period of freezing in cooled air followed by a period of thawing in water. A comparison is made between the bending moment of the specimen exposed to freeze-thaw test cycling and the bending moment of an unexposed reference specimen from the same sample for all the samples in the lot.

H.3 Apparatus

H.3.1 Freeze-thaw test apparatus, consisting of the following items:

- freezing unit with forced-air circulation and air temperature control, capable of reaching the temperature specified in H.4.1 within 1 h to 2 h with a full load of specimens;
- water bath, filled with water saturated with soluble salts derived from fibre-cement products, at a temperature of $20\text{ °C} \pm 4\text{ °C}$;
- test equipment for determination of bending moment; see Annex D.

H.4 Freeze-thaw performance of sheets

H.4.1 Procedure

Divide the specimens at random into two lots of 10.

Submit the first lot of 10 specimens to the bending moment test (see Annex D), including the conditioning procedure for type testing; see Table 7. Record the results.

At the same time, immerse the second lot of specimens in water at ambient temperature ($> 5\text{ °C}$) for 48 h.

After this period of saturation, submit this second lot of specimens to 100 freeze-thaw cycles consisting of the following phases.

- Cool (freeze) in air to a temperature of $-20\text{ °C} \pm 4\text{ °C}$ in not less than 1 h and not more than 2 h; keep the specimens at this temperature for a further 1 h.
- Heat (thaw) in water to reach a temperature of $20\text{ °C} \pm 4\text{ °C}$ within 1 h to 2 h maximum and hold at this temperature for a further 1 h.

Each freeze-thaw cycle shall take between 4 h and 6 h, but an interval of 72 h maximum may be taken between cycles, during which the specimens shall be stored in water at $20\text{ °C} \pm 4\text{ °C}$.

After completion of the required number of cycles, condition the immersed specimens in accordance with the conditioning procedure for type testing, as given in Table 7, and carry out the bending moment test; see Annex D. Record the results.

NOTE 1 The temperature specified above refers to the freezing cavity.

NOTE 2 During both the freezing and thawing cycles, it is necessary to position the specimens to enable free circulation of the conducting medium (air in the freezer or water in the bath) around them.

H.4.2 Calculation of results

For each of the two lots, calculate the mean bending moment and the standard deviation at the value obtained.

Let \bar{X}_1 and s_1 be the mean and the standard deviation of the results obtained on the first lot, and \bar{X}_2 and s_2 be the mean and the standard deviation of the results obtained on the second lot tested after freeze-thaw cycles.

The lower estimation, L_2 , of the mean bending moment after the freeze-thaw cycles (second lot) at the 95 % confidence level is calculated as given in Equation (H.1) and the upper estimation, L_1 , of the mean bending moment at the 95 % confidence level of the reference (first) lot is calculated according to Equation (H.2):

$$L_2 = \bar{X}_2 - (0,58 \times s_2) \quad (\text{H.1})$$

$$L_1 = \bar{X}_1 + (0,58 \times s_1) \quad (\text{H.2})$$

where the coefficient of 0,58 is related to a sampling size of 10 specimens, in accordance with ISO 2602:1980, Table 1, for the unilateral level of confidence at 95 %.

Calculate the ratio, R_L , as given in Equation (H.3):

$$R_L = \frac{L_2}{L_1} \quad (\text{H.3})$$

Assess the ratio against the specification of 5.4.5.1.

H.5 Freeze-thaw performance of fittings — Procedure

Submit the five specimens to saturation by immersing them in a water bath filled with water at ambient temperature ($> 5\text{ °C}$) for 48 h.

After this period of saturation, subject the specimens to 100 freeze-thaw cycles as described in H.4.1.

After completion of the required number of cycles, inspect the specimens visually for compliance with the specification given in 5.4.5.2

H.6 Test report

The test report shall contain the following information:

- a reference to this International Standard;
- all details necessary for complete identification of the batch of profiled sheets from which sample sheets were taken;
- dimensions of the test specimen;
- test equipment details;
- test temperature and condition of the test pieces;
- bending moments of exposed and unexposed sheet specimens and the visual condition of the test specimens at conclusion of the test;
- calculated results;
- date of testing.

Annex I (normative)

Test method to determine the heat-rain performance of sheets

I.1 General

This annex gives the details of the apparatus and testing procedure required to evaluate the heat-rain performance of fibre-cement profiled sheets.

I.2 Principle

Sample sheets are fixed to a framing system in such a way as to simulate a typical roof installation system. The test assembly is subjected to a number of test cycles comprised of water spraying and radiant heating. A visual assessment of the sheet performance is made.

I.3 Apparatus

I.3.1 Heat-rain test apparatus, consisting of the following:

- suitable construction with an inclined frame to which the sheets shall be fixed;

Spacing of framing members and type of material used shall be specified by the manufacturer. The inclination of the frame shall be $35^\circ \pm 10^\circ$. The dimensions of the frame are such as to allow at least one sheet of minimum length of 1,2 m and of full width to be tested when installed with appropriate overlapping strips at four edges.

- water-spray system, which provides a complete wetting of the upper face of the sheets, at a water flow rate of approximately 2,5 l/m²·min, and with the water at ambient temperature (> 5 °C);
- device capable of heating and uniformly maintaining the surface of the specimens within the following specified temperature requirements:
 - 1) The heating device shall be controlled via a black-body sensor positioned at the central area of the test rig where the maximum temperature is expected. It should provide an approximately uniform power output during the heating period.

NOTE For this test, an aluminum plate 1 mm thick painted with mat black paint is used as a black-body. The measurement device is a thermocouple or a similar device fixed on the surface of the aluminum plate.
 - 2) The temperature at the sensor location shall be maintained at $70\text{ °C} \pm 5\text{ °C}$ and this temperature shall be reached within 15 min of the commencement of heating.
 - 3) The difference between the black-body temperature in the centre of the rig and the edges of the rig shall not exceed 15 °C.
- control system capable of providing cycles in accordance with Table I.1.

I.4 Test procedure

I.4.1 After conditioning the specimens, install them on the frame in accordance with national standards or codes or, in their absence, the manufacturer's recommendations with respect to fixing and overlapping. Lay each sheet with overlaps at the four edges. At the perimeter of the frame, overlaps can be provided by strips of sheets.

I.4.2 Subject the upper face of the assembled specimens to the water spray and heating cycle given in Table I.1.

Table I.1 — Heat-rain cycle

Cycle	Duration
Water spray (2,5 l/m ² ·min)	2 h 50 min ± 5 min
Pause	5 min to 10 min
Radiant heat (70 °C ± 5 °C)	2 h 50 min ± 5 min
Pause	5 min to 10 min
Total cycle	5 h 55 min ± 15 min

I.4.3 Repeat to reach the prescribed number of 50 cycles (refer 5.4.6).

I.4.4 After completion of the required number of cycles without interruption, inspect the sheets for cracking (longitudinal, transverse and at the fixing points), delamination and other visible defects. Verify compliance with the specification given in 5.4.6.

I.5 Test report

The test report shall contain the following information:

- a reference to this International Standard;
- all details necessary for complete identification of the batch of profiled sheets from which sample sheets were taken;
- dimensions of the test specimen;
- test equipment details;
- test temperature and condition of the test pieces;
- visual condition of the test specimens at the conclusion of the test;
- date of testing.

Annex J (normative)

Test method to determine the warm water performance of long and short sheets

J.1 General

This annex gives the details of the apparatus and testing procedure required to evaluate the warm water performance of long and short fibre-cement profiled sheets.

J.2 Principle

A lot of specimens is subjected to a period of immersion in warm water. A comparison is made between the breaking load (long sheets) or the bending moment (short sheets) of the warm-water-immersed specimen to the breaking load (long sheets) or the bending moment (short sheets) of the lot of un-immersed reference specimens for the same sample, for each sample in the lot.

J.3 Apparatus

J.3.1 Water bath, capable of being controlled to $60\text{ °C} \pm 3\text{ °C}$.

The water in the water bath should be saturated with soluble salts derived from pieces of fibre-cement sheets. The pieces of product used shall be broken down to a small size and be of sufficient quantity to ensure saturation is complete.

J.3.2 Test equipment, for determination of breaking load or bending moment; see Annexes C and D.

J.4 Procedure

Divide the specimens at random into two lots of 10.

Submit the first lot of 10 specimens to the breaking load test for the long sheets (taking for w the average of the two measurements of the specimen width) or to the bending moment test for the short sheets, including the conditioning procedure for type testing (see Table 7).

At the same time, immerse the second lot of 10 specimens in the water bath at a temperature of $60\text{ °C} \pm 3\text{ °C}$ for a period of $56\text{ d} \pm 2\text{ d}$.

After completion of the required number of days in warm water, condition the immersed specimens according to the conditioning procedure for type testing as given in Table 7. Examine the specimens with the naked eye in order to detect any cracks or obvious defects such as can affect their performance in use, and record any observations. Carry out the breaking load test for long sheets (taking for w the average of the two measurements of the specimen width) or the bending moment test for short sheets.

J.5 Calculation of results

For each of the two lots, calculate the mean breaking load or bending moment and the standard deviation of the values obtained.

Let \bar{X}_1 and s_1 be the mean and the standard deviation of the results obtained on the first lot, and \bar{X}_2 and s_2 be the mean and the standard deviation of the results obtained on the second lot tested after the period of immersion in warm water.

The lower estimation, L_2 , of the mean breaking load or bending moment after immersion in warm water (second lot) at the 95 % confidence level is calculated as given in Equation (J.1) and the upper estimation, L_1 , of the mean breaking load or bending moment at the 95 % confidence level of the reference (first) lot is calculated according to Equation (J.2):

$$L_2 = \bar{X}_2 - (0,58 \times s_2) \quad (\text{J.1})$$

$$L_1 = \bar{X}_1 + (0,58 \times s_1) \quad (\text{J.2})$$

where the coefficient of 0,58 is related to a sampling size of 10 specimens, as defined in ISO 2602:1980, Table 1, for the unilateral level of confidence at 95 %.

Calculate the ratio, R_L , as given in Equation (J.3):

$$R_L = \frac{L_2}{L_1} \quad (\text{J.3})$$

Assess the ratio against the specification of 5.4.7.

J.6 Test report

The test report shall contain the following information:

- a reference to this International Standard;
- all details necessary for complete identification of the batch of profiled sheets from which sample sheets were taken;
- dimensions of the test specimen;
- test equipment details;
- test temperature and condition of the test pieces;
- breaking loads or bending moments of exposed and unexposed sheet specimens and the visual condition of the test specimens at conclusion of the test;
- calculated results;
- date of testing.

Annex K (normative)

Test method to determine the soak-dry performance of long and short sheets

K.1 General

This annex gives the details of the apparatus and testing procedure required to evaluate the soak-dry performance of long and short fibre-cement profiled sheets.

K.2 Principle

A lot of specimens is subjected to a number of test cycles comprising a period of immersion in water and drying in an oven. A comparison is made between the breaking load (long sheets) or the bending moment (short sheets) of the specimen exposed to soak-dry test cycling and the breaking load (long sheets) or the bending moment (short sheets) of the unexposed reference specimen from the same sample for each sample in the lot.

K.3 Apparatus

K.3.1 Oven, ventilated, capable of maintaining a temperature of $60\text{ °C} \pm 3\text{ °C}$ and a relative humidity less than or equal to 20 % with a full load of specimens.

K.3.2 Bath, filled with water at ambient temperature ($> 5\text{ °C}$).

The water in the water bath should be saturated with soluble salts derived from fibre-cement sheets.

K.3.3 Test equipment, for determination of breaking load or bending moment; see Annexes C and D.

K.4 Procedure

Divide the specimens at random into two lots of 10.

Submit the first lot of 10 specimens to the breaking load test for the long sheets (taking for w the average of two measurements of the width of the specimen) or to the bending moment test for the short sheets, including the conditioning procedure for type testing; see Table 7.

At the same time, submit the second lot of 10 specimens to 50 soak-dry cycles as follows:

- immersion in water at ambient temperature ($> 5\text{ °C}$) for 18 h;
- drying in a ventilated oven at $60\text{ °C} \pm 3\text{ °C}$ and a relative humidity of less than 20 % for 6 h. The 20 % humidity shall be achieved for at least 3 h prior to the end of the drying period.

If necessary, an interval of up to 72 h is allowed between cycles. During this interval, store specimens in the immersed condition.

After completion of the required number of cycles, condition the immersed specimens according to the conditioning procedure for type testing in accordance with Table 7, and carry out the breaking load test for

long sheets (taking for w the average of two measurements of the width of the specimen) or the bending moment test for short sheets.

K.5 Calculation of results

For each of the two lots, calculate the mean breaking load or bending moment and the standard deviation of the values obtained.

Let \bar{X}_1 and s_1 be the mean and the standard deviation of the results obtained on the first lot, and \bar{X}_2 and s_2 be the mean and the standard deviation of the results obtained on the second lot tested after the soak-dry cycles.

The lower estimation, L_2 , of the mean breaking load or bending moment after immersion in warm water (second lot) at the 95 % confidence level is calculated as given in Equation (K.1) and the upper estimation, L_1 , of the mean breaking load or bending moment at the 95 % confidence level of the reference (first) lot is calculated according to Equation (K.2):

$$L_2 = \bar{X}_2 - (0,58 \times s_2) \tag{K.1}$$

$$L_1 = \bar{X}_1 + (0,58 \times s_1) \tag{K.2}$$

where the coefficient of 0,58 is related to a sampling size of 10 specimens, as defined in ISO 2602:1980, Table 1, for the unilateral level of confidence at 95 %.

Calculate the ratio, R_L , as given in Equation (K.3):

$$R_L = \frac{L_2}{L_1} \tag{K.3}$$

Assess the ratio against the specification of 5.4.8.

K.6 Test report

The test report shall contain the following information:

- a reference to this International Standard;
- all details necessary for complete identification of the batch of profiled sheets from which sample sheets were taken;
- dimensions of the test specimen;
- test equipment details;
- test temperature and condition of the test pieces;
- breaking loads or bending moments of exposed and unexposed sheet specimens;
- calculated results;
- date of testing.

Bibliography

- [1] EN 494, *Fibre-cement profiled sheets and fittings — Product specification and test methods*
- [2] ISO 9001, *Quality management systems — Requirements*

ICS 91.100.40

Price based on 53 pages