Tool holders with cylindrical shank —
Part 7:
Type F with taper seat

Porte-outil à queue cylindrique —

Partie 7: Porte-outil de type F pour outils à queue conique



COPYRIGHT PROTECTED DOCUMENT

© ISO 2016, Published in Switzerland

All rights reserved. Unless otherwise specified, no part of this publication may be reproduced or utilized otherwise in any form or by any means, electronic or mechanical, including photocopying, or posting on the internet or an intranet, without prior written permission. Permission can be requested from either ISO at the address below or ISO's member body in the country of the requester.

ISO copyright office
Ch. de Blandonnet 8 • CP 401
CH-1214 Vernier, Geneva, Switzerland
Tel. +41 22 749 01 11
Fax +41 22 749 09 47
copyright@iso.org
www.iso.org

Contents

	Page
Foreword	iv
1 Scope	1
2 Normative references	1
3 Dimensions	1
4 Designation	3
5 Technical delivery conditions	3
Annex A (informative) Relationship between designations in this part of ISO 10889 and ISO 13399	4
Bibliography	5

Foreword

ISO (the International Organization for Standardization) is a worldwide federation of national standards bodies (ISO member bodies). The work of preparing International Standards is normally carried out through ISO technical committees. Each member body interested in a subject for which a technical committee has been established has the right to be represented on that committee. International organizations, governmental and non-governmental, in liaison with ISO, also take part in the work. ISO collaborates closely with the International Electrotechnical Commission (IEC) on all matters of electrotechnical standardization.

The procedures used to develop this document and those intended for its further maintenance are described in the ISO/IEC Directives, Part 1. In particular the different approval criteria needed for the different types of ISO documents should be noted. This document was drafted in accordance with the editorial rules of the ISO/IEC Directives, Part 2 (see www.iso.org/directives).

Attention is drawn to the possibility that some of the elements of this document may be the subject of patent rights. ISO shall not be held responsible for identifying any or all such patent rights. Details of any patent rights identified during the development of the document will be in the Introduction and/or on the ISO list of patent declarations received (see www.iso.org/patents).

Any trade name used in this document is information given for the convenience of users and does not constitute an endorsement.

For an explanation on the meaning of ISO specific terms and expressions related to conformity assessment, as well as information about ISO's adherence to the WTO principles in the Technical Barriers to Trade (TBT) see the following URL: [Foreword - Supplementary information](#)

The committee responsible for this document is ISO/TC 29, *Small tools*, Subcommittee SC 2, *Holding tools, adaptive items and interfaces*.

This third edition cancels and replaces the second edition (ISO 10889-7:2004), of which it constitutes a minor revision, notably with the addition of [Annex A](#), which gives the relationship between the designations of this part of ISO 10889 and the ISO 13399 series.

ISO 10889 consists of the following parts, under the general title *Tool holders with cylindrical shank*:

- *Part 1: Cylindrical shank, location bore — Technical delivery conditions*
- *Part 2: Type A, shanks for tool holders of special designs*
- *Part 3: Type B with rectangular radial seat*
- *Part 4: Type C with rectangular axial seat*
- *Part 5: Type D with more than one rectangular seat*
- *Part 6: Type E with cylindrical seat*
- *Part 7: Type F with taper seat*
- *Part 8: Type Z, accessories*

Tool holders with cylindrical shank —

Part 7: Type F with taper seat

1 Scope

This part of ISO 10889 specifies dimensions, designations, and complementary technical delivery conditions for tool holders with taper seat of type F and with a cylindrical shank mounting system in accordance with ISO 10889-1.

ISO 10889 is applicable to tool holders with cylindrical shank for machine tools with non-rotating tools, preferably for turning machines.

For non-standardized tool holders with taper seat such as the tool holders shown in [Figure 1](#), it is advisable to apply the corresponding specifications of this part of ISO 10889.

2 Normative references

The following documents, in whole or in part, are normatively referenced in this document and are indispensable for its application. For dated references, only the edition cited applies. For undated references, the latest edition of the referenced document (including any amendments) applies.

ISO 296, *Machine tools — Self-holding tapers for tool shanks*

ISO 2768-1, *General tolerances — Part 1: Tolerances for linear and angular dimensions without individual tolerance indications*

ISO 2768-2, *General tolerances — Part 2: Geometrical tolerances for features without individual tolerance indications*

ISO 10889-1, *Tool holders with cylindrical shank — Part 1: Cylindrical shank, location bore — Technical delivery conditions*

3 Dimensions

All dimensions and tolerances are given in millimetres. Tolerancing is done according to ISO 8015. Tolerances not specified shall be of tolerance class “m” in accordance with ISO 2768-1 and of class “H” in accordance with ISO 2768-2.

Unspecified details shall be chosen appropriately.

The dimensions of tool holders type F shall be in accordance with the dimensions shown in [Figure 1](#) and given in [Table 1](#).

The relationship between the symbols of this part of ISO 10889 and the symbols according to ISO 13399 is given in [Annex A](#).

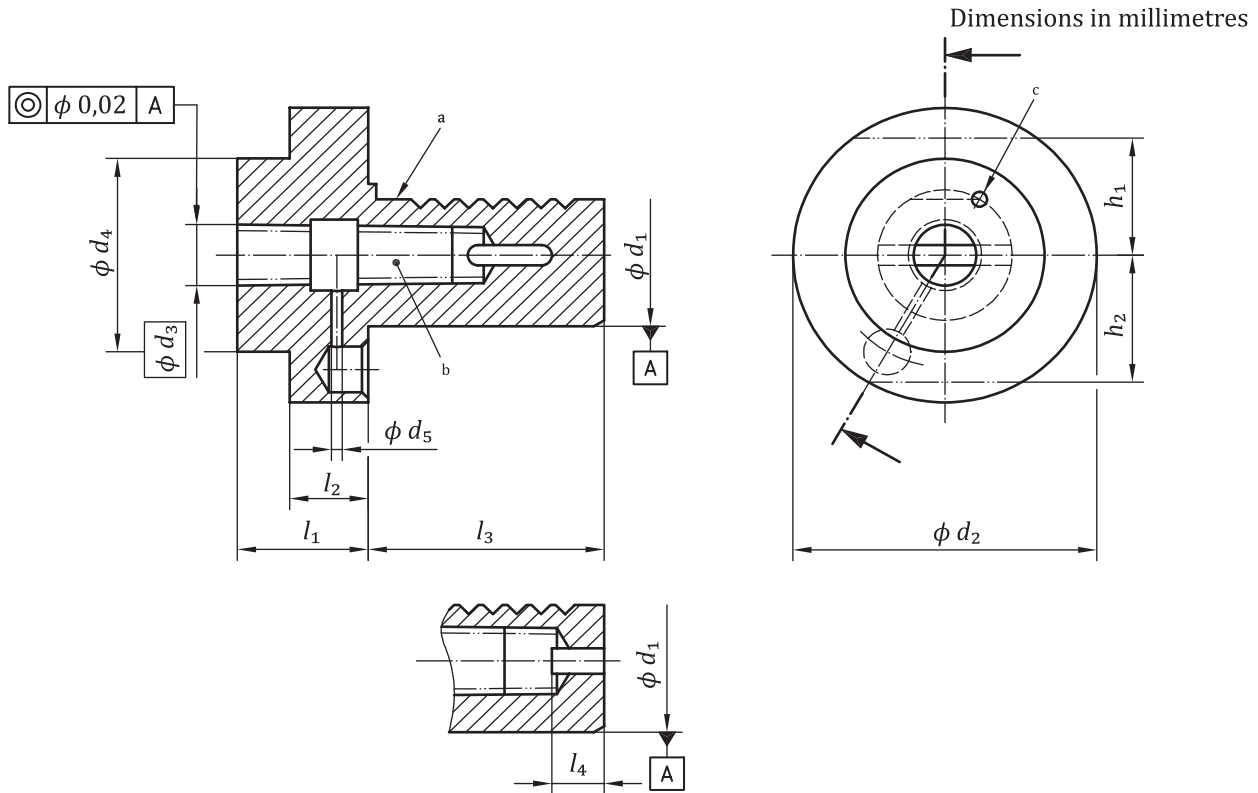

Key

- a Cylindrical shank in accordance with ISO 10889-1.
- b Internal Morse taper, type BIK in accordance with ISO 296.
- c External coolant supply (closable).

Figure 1 — Taper seat type F tool holder for taper shanks with flat tang

Table 1 — Type F tool holder dimensions

Dimensions in millimetres

d_1	Internal Morse taper, type BIK No.	d_2	d_3	d_4	d_5	h_1	h_2	l_1	l_2	l_3	l_4
20	1	50	12,065	—	—	—	23	23	—	40	7 ^a
25	1	58	12,065	—	—	25	25	23	—	48	—
	2		17,780	—	5			27	—		—
30	1	68	12,065	—	—	28	30	27	—	55	—
	2		17,780	—	5			—	—		14 ^a
40	2	83	17,780	55	5	32,5	—	36	22	63	—
	3		23,825	58	6			80			14 ^a
	4		31,267	68	7			—			—
50	2	98	17,780	55	5	35	—	36	30	78	—
	3		23,825	58	6			80			—
	4		31,267	68	7			—			18 ^a

^a These sizes have a recess for taper shanks with flat tang up to the end face of the cylindrical shank. The design of slot is at the discretion of the manufacturer.

Table 1 (continued)

d_1	Internal Morse taper, type BIK No.	d_2	d_3	d_4	d_5	h_1	h_2	l_1	l_2	l_3	l_4
60	3	123	23,825	58	6	42,5	—	36	30	94	—
	4		31,267	68	7			50			—
	5		44,399	98	7			63			32 ^a
80	4	158	31,267	68	7	55	—	50	40	104	—
	5		44,399	98							—

^a These sizes have a recess for taper shanks with flat tang up to the end face of the cylindrical shank. The design of slot is at the discretion of the manufacturer.

4 Designation

A type F tool holder with Morse taper seat in accordance with this part of ISO 10889 shall be designated by the following:

- “tool holder”;
- reference to this part of ISO 10889, i.e. ISO 10889-7;
- type (F);
- nominal diameter, d_1 , in millimetres;
- internal taper type;
- if applicable, hardened contact surface (H).

EXAMPLE 1 A type F tool holder with a Morse taper seat, a nominal diameter, $d_1 = 40$ mm, and an internal taper, type BIK 3, is designated as follows:

Tool holder ISO 10889-7 - F - 40 - MT-BIK 3

EXAMPLE 2 A type F tool holder with a Morse taper seat and nominal diameter, $d_1 = 40$ mm, an internal taper, type BIK 3, and hardened contact surface is designated as follows:

Tool holder ISO 10889-7 - F - 40 - MT-BIK 3 H

5 Technical delivery conditions

As a complement to the requirements of ISO 10889-1, the following requirements also apply.

The taper socket shall be hardened with a surface hardness of (56^{+4}_0) HRC and a depth of hardening of at least 0,5 mm.

The taper angle tolerance class of taper socket shall be AT5 in accordance with ISO 296.

Tool holders can also be supplied with hardened contact surface.

Annex A (informative)

Relationship between designations in this part of ISO 10889 and ISO 13399

For the relationship between the symbols of this part of ISO 10889 and the symbols according to ISO 13399, see [Table A.1](#).

Table A.1 — Relationship between symbols in this part of ISO 10889 and ISO 13399

Symbol in this part of ISO 10889	Reference in this part of ISO 10889	Property name in ISO 13399 series	Symbol in ISO 13399 series	Reference in ISO 13399 series BSU code
d_1	Figure 1	connection diameter machine side	DCONMS	71EBDBF5060E6
d_2	Figure 1	flange diameter	DF	71EC61D8A1771
d_3	Figure 1	functional diameter	DFC	7272379AD9C85
d_4	Figure 1	body diameter	DB	71ED6A9AF7D1D
d_5	Figure 1	—	—	—
l_1	Figure 1	protruding length	LPR	71DCD394BB20E
l_2	Figure 1	flange thickness	FLGT	71EEF53809764
l_3	Figure 1	shank length	LS	71CF298870946
l_4	Figure 1	—	—	—
h_1	Figure 1	—	OAH ^a – RADH	—
h_2	Figure 1	radial height	RADH	726E3E86B5284

^a OAH is the “overall height” (code BSU 71D078EB73E87).

Bibliography

- [1] ISO 8015, *Geometrical product specifications (GPS) — Fundamentals — Concepts, principles and rules*
- [2] ISO 13399 (all parts), *Cutting tool data representation and exchange*

