

---

---

**Tool holders with cylindrical shank —**  
**Part 6:**  
**Type E with cylindrical seat**

*Porte-outil à queue cylindrique —*

*Partie 6: Porte-outil de type E pour outils à queue cylindrique*



**COPYRIGHT PROTECTED DOCUMENT**

© ISO 2016, Published in Switzerland

All rights reserved. Unless otherwise specified, no part of this publication may be reproduced or utilized otherwise in any form or by any means, electronic or mechanical, including photocopying, or posting on the internet or an intranet, without prior written permission. Permission can be requested from either ISO at the address below or ISO's member body in the country of the requester.

ISO copyright office  
Ch. de Blandonnet 8 • CP 401  
CH-1214 Vernier, Geneva, Switzerland  
Tel. +41 22 749 01 11  
Fax +41 22 749 09 47  
copyright@iso.org  
www.iso.org

# Contents

	Page
<b>Foreword</b> .....	<b>iv</b>
<b>1 Scope</b> .....	<b>1</b>
<b>2 Normative references</b> .....	<b>1</b>
<b>3 Dimensions</b> .....	<b>1</b>
3.1 General .....	1
3.2 Tool holder of type E1 .....	1
3.3 Tool holder of type E2 .....	3
3.4 Tool holder of type E3 .....	5
3.5 Tool holder of type E4 .....	6
<b>4 Designation</b> .....	<b>7</b>
<b>5 Technical delivery conditions</b> .....	<b>8</b>
5.1 General .....	8
5.2 Design .....	8
5.3 Scope of delivery .....	8
<b>Annex A (informative) Relationship between designations in this part of ISO 10889 and ISO 13399</b> .....	<b>9</b>
<b>Bibliography</b> .....	<b>10</b>

## Foreword

ISO (the International Organization for Standardization) is a worldwide federation of national standards bodies (ISO member bodies). The work of preparing International Standards is normally carried out through ISO technical committees. Each member body interested in a subject for which a technical committee has been established has the right to be represented on that committee. International organizations, governmental and non-governmental, in liaison with ISO, also take part in the work. ISO collaborates closely with the International Electrotechnical Commission (IEC) on all matters of electrotechnical standardization.

The procedures used to develop this document and those intended for its further maintenance are described in the ISO/IEC Directives, Part 1. In particular the different approval criteria needed for the different types of ISO documents should be noted. This document was drafted in accordance with the editorial rules of the ISO/IEC Directives, Part 2 (see [www.iso.org/directives](http://www.iso.org/directives)).

Attention is drawn to the possibility that some of the elements of this document may be the subject of patent rights. ISO shall not be held responsible for identifying any or all such patent rights. Details of any patent rights identified during the development of the document will be in the Introduction and/or on the ISO list of patent declarations received (see [www.iso.org/patents](http://www.iso.org/patents)).

Any trade name used in this document is information given for the convenience of users and does not constitute an endorsement.

For an explanation on the meaning of ISO specific terms and expressions related to conformity assessment, as well as information about ISO's adherence to the WTO principles in the Technical Barriers to Trade (TBT) see the following URL: [Foreword - Supplementary information](#)

The committee responsible for this document is ISO/TC 29, *Small tools*, Subcommittee SC 2, *Holding tools, adaptive items and interfaces*.

This third edition cancels and replaces the second edition (ISO 10889-6:2004), of which it constitutes a minor revision, notably with the addition of [Annex A](#), which gives the relationship between the designations of this part of ISO 10889 and the ISO 13399 series.

ISO 10889 consists of the following parts, under the general title *Tool holders with cylindrical shank*:

- *Part 1: Cylindrical shank, location bore — Technical delivery conditions*
- *Part 2: Type A, shanks for tool holders of special designs*
- *Part 3: Type B with rectangular radial seat*
- *Part 4: Type C with rectangular axial seat*
- *Part 5: Type D with more than one rectangular seat*
- *Part 6: Type E with cylindrical seat*
- *Part 7: Type F with taper seat*
- *Part 8: Type Z, accessories*

# Tool holders with cylindrical shank —

## Part 6: Type E with cylindrical seat

### 1 Scope

This part of ISO 10889 specifies dimensions, designations, and complementary technical delivery conditions for tool holders with cylindrical seat of types E1 to E4 with a mounting system cylindrical shank in accordance with ISO 10889-1.

ISO 10889 is applicable to tool holders with cylindrical shank for machine tools with non-rotating tools, preferably for turning machines.

For non-standardized tool holders, such as tool holders with a cylindrical seat as shown in [Figures 1 to 4](#), it is advisable to apply the corresponding specifications of this part of ISO 10889.

### 2 Normative references

The following documents, in whole or in part, are normatively referenced in this document and are indispensable for its application. For dated references, only the edition cited applies. For undated references, the latest edition of the referenced document (including any amendments) applies.

ISO 2768-1, *General tolerances — Part 1: Tolerances for linear and angular dimensions without individual tolerance indications*

ISO 2768-2, *General tolerances — Part 2: Geometrical tolerances for features without individual tolerance indications*

ISO 10889-1, *Tool holders with cylindrical shank — Part 1: Cylindrical shank, location bore — Technical delivery conditions*

ISO 10897, *Collets for tool holders with taper ratio 1:10 — Collets, holders, nuts*

ISO 15488, *Collets with 8 degree setting angle for tool shanks — Collets, nuts and fitting dimensions*

### 3 Dimensions

#### 3.1 General

All dimensions and tolerances are given in millimetres. Tolerancing is done according to ISO 8015. Tolerances not specified shall be of tolerance class “m” in accordance with ISO 2768-1 and of class “H” in accordance with ISO 2768-2.

Unspecified details shall be chosen appropriately.

The relationship between the symbols of this part of ISO 10889 and the symbols according to ISO 13399 is given in [Annex A](#).

#### 3.2 Tool holder of type E1

The dimensions of tool holders type E1 shall be in accordance with the dimensions shown in [Figure 1](#) and given in [Table 1](#).

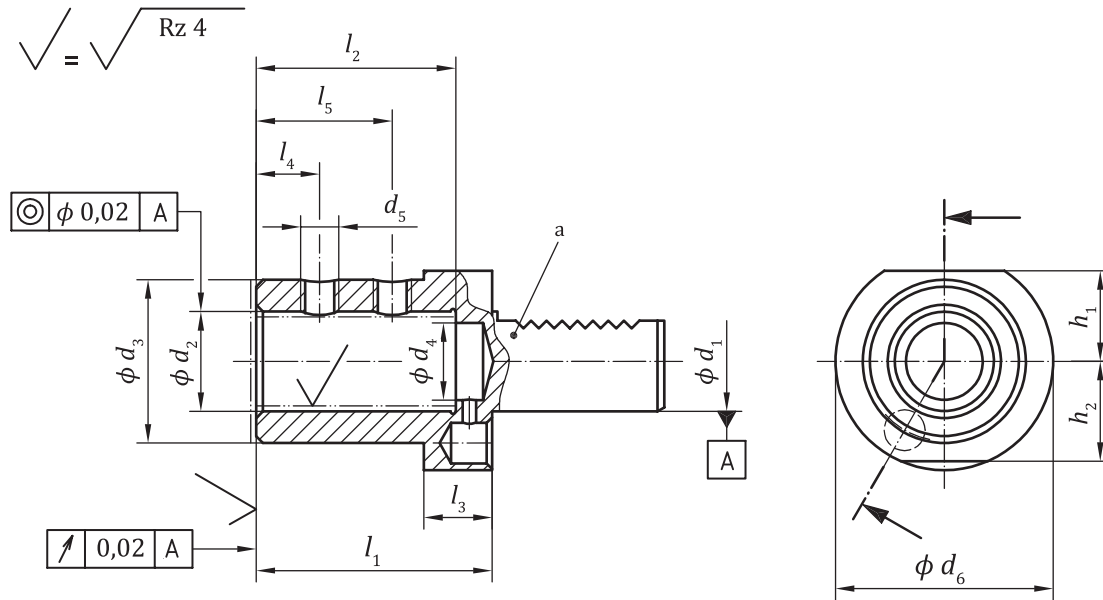

**Key**

a Cylindrical shank in accordance with ISO 10889-1.

NOTE Surface roughness is given in micrometres.

**Figure 1 — Type E1 tool holder for drilling tools with internal coolant supply**

**Table 1 — Type E1 tool holder dimensions**

Dimensions in millimetres

$d_1$	$d_2$ H6	$d_3$	$d_4^a$	$d_5$	$d_6$	$h_1$	$h_2$	$l_1$ 0 -0,2	$l_2$	$l_3$	$l_4$	$l_5$
20	20	40	12	M10 × 1	50	—	23	67	54	18	15	35
	25	45	17	M12 × 1				71	59		17	40
25	20	40	12	M10 × 1	58	25	25	67	54	18	15	35
	25	45	17	M12 × 1				71	59		17	40
30	20	40	12	M10 × 1	68	28	30	67	54	22	15	35
	25	45	17	M12 × 1				71	59		17	40
	32	52	24					75	63		17	44
40	20	40	12	M10 × 1	83	32,5	—	67	54	22	15	35
	25	45	17	M12 × 1				75	59		17	40
	32	52	24					75	63		17	44
	40	65	32	M16 × 1				90	73		22	50
50	20	40	12	M10 × 1	98	35	—	67	54	30	15	35
	25	45	17	M12 × 1				80	59		17	40
	32	52	24					80	63		17	44
	40	65	32	M16 × 1				90	73		22	50
	50	75	42					100	83		24	60

<sup>a</sup>  $d_4$  shall be pilot-drilled for manufacturing reasons.



**Table 2 — Type E2 tool holder dimensions**

Dimensions in millimetres

$d_1$	$d_2$ H7	$d_6$	$d_7$ min.	$d_8$	$d_9^a$	$h_1$	$h_2$	$l_3$	$l_6$	$l_7$
16	6	40	6,7	32	M6	18	18	13	44	34
	8									
	10									
	12			40	M8					
	16									
20	8	50	9	40	M6	—	23	18	50	41
	10									
	12									
	16			50	M8				60	51
	20									
	25									
25	8	58	10,5	40	M6	25	25	18	50	41
	10									
	12									
	16			58	M8				60	51
	20									
	25									
30	8	68	16,5	55	M6	28	30	22	60	51
	10									
	12									
	16									
	20			58	M8				75	61
	25									
	32									
40	12	83	20,5	55	M8	32,5	—	22	75	61
	16									
	20									
	25			83	M10				90	76
	32									
	40									
50	16	98	25,5	68	M10	35	—	30	90	76
	20									
	25									
	32			98	M12				100	86
	40									
	50									

<sup>a</sup> For  $d_1 = 20$  mm: at least two fastening threads; other sizes at least three fastening threads.



Table 2 (continued)

$d_1$	$d_2$ H7	$d_6$	$d_7$ min.	$d_8$	$d_9^a$	$h_1$	$h_2$	$l_3$	$l_6$	$l_7$	
60	16	123	40,5	68	M10	42,5	—	30	90	76	
	20				M12						
	25										
	32										
	40			98	100						86
	50										
80	20	158	40,5	68	M12	55	—	30	100	86	
	25										
	32										
	40			98							
	50										

<sup>a</sup> For  $d_1 = 20$  mm: at least two fastening threads; other sizes at least three fastening threads.

### 3.4 Tool holder of type E3

The dimensions of tool holders type E3 shall be in accordance with the dimensions shown in [Figure 3](#) and given in [Table 3](#).

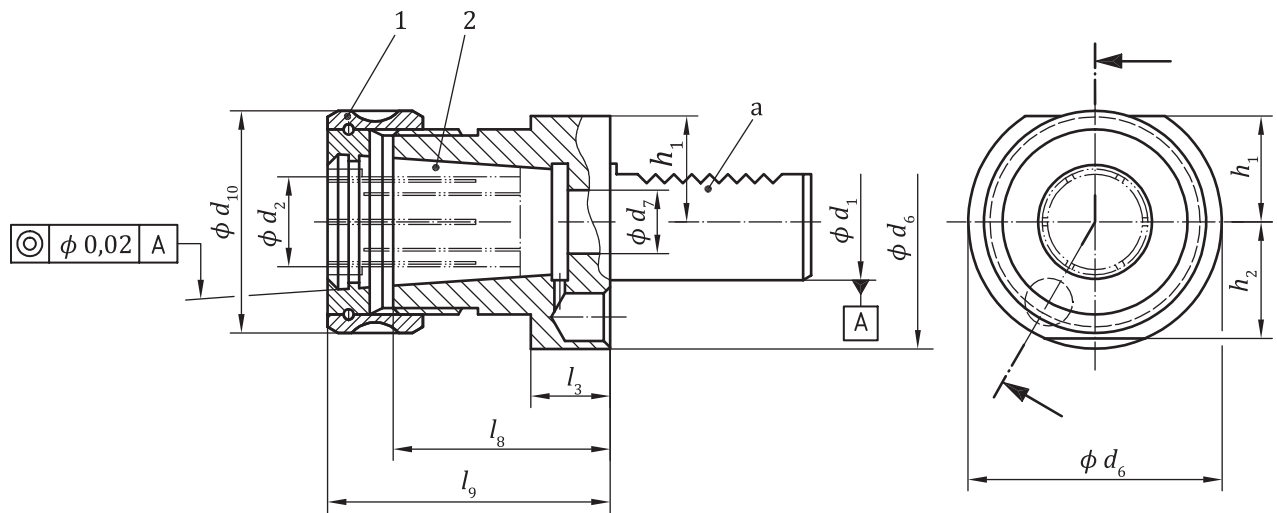

**Key**

- 1 nut, form D, in accordance with ISO 10897
- 2 collet, form C, in accordance with ISO 10897
- a Cylindrical shank in accordance with ISO 10889-1.

Figure 3 — Type E3 tool holder with cylindrical seat by collet in accordance with ISO 10897

**Table 3 — Type E3 tool holder dimensions**

Dimensions in millimetres

$d_1$	Nominal size for collet and nut	$d_2$		$d_6$	$d_7$ min.	$d_{10}$ max.	$h_1$	$h_2$	$l_3$	$l_8$	$l_9$ max.
		Form A	Form B								
16	12	1 to 12	—	40	6,7	35	18	18	13	36	45,5
20	16	2 to 16	5 to 16	50	9	43	—	23	18	42	57
	20	2 to 20	6 to 20			50				46	62
25	16	2 to 16	5 to 16	58	10,5	43	25	25	18	42	57
	20	2 to 20	6 to 20			50				46	62
30	16	2 to 16	5 to 16	68	16,5	43	28	30	22	42	57
	25	2 to 25	6 to 25			60				59	75
40	25	2 to 25	6 to 25	83	20,5	60	32,5	—	22	59	75
	32	4 to 32	10 to 32			72				73	90
50	25	2 to 25	6 to 25	98	25,5	60	35	—	30	59	75
	32	4 to 32	10 to 32			72				73	90
60	25	2 to 25	6 to 25	123	40,5	60	42,5	—	30	59	75
	32	4 to 32	10 to 32			72				73	90
	40	6 to 29,5	30 to 40			85				82	100
80	40	6 to 29,5	30 to 40	158	40,5	85	55	—	40	82	100

**3.5 Tool holder of type E4**

The dimensions of tool holders type E4 shall be in accordance with the dimensions shown in [Figure 4](#) and given in [Table 4](#).

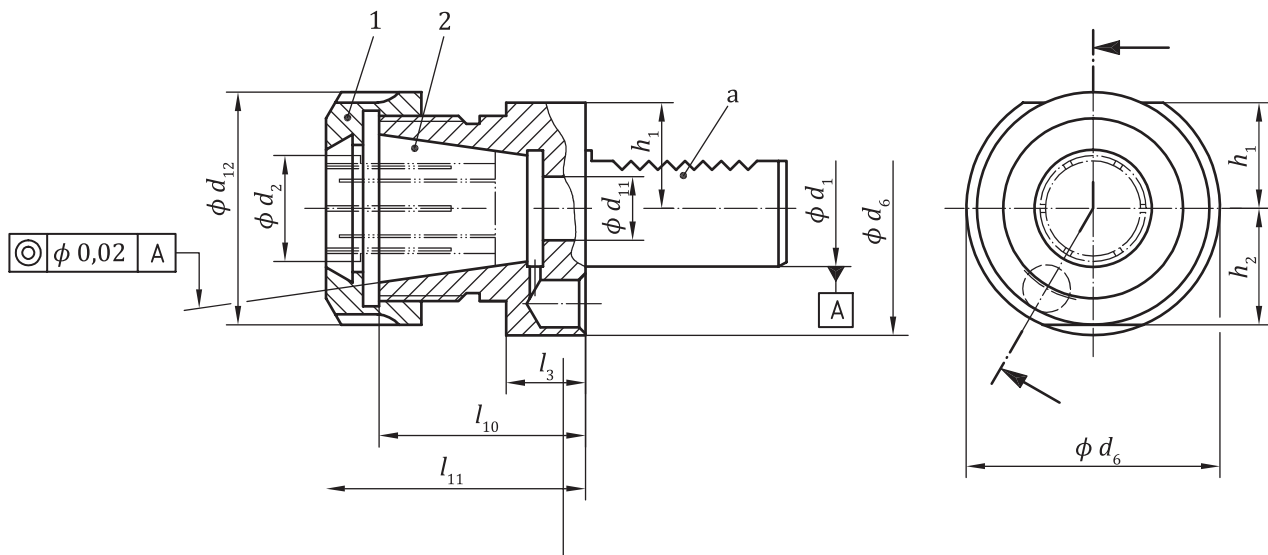

**Key**

- 1 nut, form D, in accordance with ISO 15488
- 2 collet, form C, in accordance with ISO 15488
- a Cylindrical shank in accordance with ISO 10889-1.

**Figure 4 — Type E4 tool holder with cylindrical seat by collet in accordance with ISO 15488**

Table 4 — Type E4 tool holder dimensions

Dimensions in millimetres

$d_1$	Nominal size for collet and nut	$d_2$ Clamping range of collet in accordance with ISO 15488		$d_6$	$d_{11}$ min.	$d_{12}$ max.	$h_1$	$h_2$	$l_3$	$l_{10}$	$l_{11}$ max.
		Form A	Form B								
16	20	1 to 13	1 to 13	40	6,7	35	18	18	13	32,5	44
20	25	1 to 16	2 to 16	50	9	42	—	23	18	38	50
	32	2 to 20	3 to 20			50				49,5	62
25	25	1 to 16	2 to 16	58	10,5	42	25	25	18	45	57
	32	2 to 20	3 to 20			50				49,5	62
30	25	1 to 16	2 to 16	68	16,5	42	28	30	22	45	57
	40	3 to 26	4 to 26			63				56	70
40	32	2 to 20	3 to 20	83	20,5	50	32,5	—	22	49,5	62
	40	3 to 26	4 to 26			63				61	75
50	40	3 to 26	4 to 26	98	25,5	63	35	—	30	61	75
60	40	3 to 26	4 to 26	123	28,5	63	42,5	—	30	61	75
80	40	3 to 26	4 to 26	158	28,5	63	55	—	40	61	75

#### 4 Designation

A type E tool holder with cylindrical seat in accordance with this part of ISO 10889 shall be designated by the following:

- “tool holder”;
- a reference to this part of ISO 10889, i.e. ISO 10889-6;
- type (E1, E2, E3, or E4)
- nominal diameter,  $d_1$ , in millimetres;
- seat diameter,  $d_2$ , in millimetres, or nominal size of the holder, in millimetres;
- if applicable, adjustable stop and hardened contact surface (A for adjustable stop, H for hardened contact surface).

EXAMPLE 1 A tool holder with cylindrical seat of type E1 with a nominal diameter  $d_1 = 40$  mm and a seat diameter  $d_2 = 25$  mm is designated as follows:

**Tool holder ISO 10889-6 - E1 × 25**

EXAMPLE 2 A tool holder with cylindrical seat of type E2 with a nominal diameter  $d_1 = 40$  mm and a seat diameter  $d_2 = 25$  mm is designated as follows:

**Tool holder ISO 10889-6 - E2 × 25**

EXAMPLE 3 A tool holder of type E2 with a nominal diameter  $d_1 = 40$  mm, a seat diameter  $d_2 = 25$  mm, with adjustable stop and hardened contact surface is designated as follows:

**Tool holder ISO 10889-6 - E2 × 25 A - H**

EXAMPLE 4 A tool holder with cylindrical seat of type E3 with a nominal diameter  $d_1 = 40$  mm and a seat diameter  $d_2 = 25$  mm is designated as follows:

**Tool holder ISO 10889-6 - E3 × 25**

## ISO 10889-6:2016(E)

EXAMPLE 5 A tool holder with cylindrical seat of type E4 with a nominal diameter  $d_1 = 40$  mm and a seat diameter  $d_2 = 32$  mm is designated as follows:

**Tool holder ISO 10889-6 - E4 × 32**

### 5 Technical delivery conditions

#### 5.1 General

As a complement to the requirements of ISO 10889-1, those given in [5.2](#) and [5.3](#) also apply.

#### 5.2 Design

For types E1 to E4 tool holders with internal coolant supply, the design is at the discretion of the manufacturer.

For type E2 tool holders with additional external coolant supply, the design is at the discretion of the manufacturer.

In the case of adjustable stops, the end face of the cylindrical shank shall be sealed to withstand a working pressure of 1 MPa (10 bar). The method of sealing is at the discretion of the manufacturer.

For type E1 tool holders, the surface of location and end face shall be hardened. The surface hardness shall be  $\left(56^{+4}_0\right)$ , the depth of hardening shall be at least 0,5 mm.

NOTE 1 bar = 0,1 MPa =  $10^5$  Pa; 1 MPa = 1 N/mm<sup>2</sup>

For types E3 and E4 tool holders, the taper surface of the mounting of the collet shall be hardened. The surface hardness shall be  $\left(56^{+4}_0\right)$  HRC, the depth of hardening shall be at least 0,5 mm.

Tool holders of types E2, E3, and E4 may be supplied with adjustable stops for pre-adjustment of the tools. The design of stop is at the discretion of the manufacturer.

#### 5.3 Scope of delivery

For types E1 and E2 tool holders, set screws for the clamping of the tools shall be supplied.

For type E3 tool holders, a nut in accordance with ISO 10897 shall be supplied.

For type E4 tool holders, a nut in accordance with ISO 15488 shall be supplied.

Collets are not included in the scope of delivery of tool holders.

## Annex A (informative)

### Relationship between designations in this part of ISO 10889 and ISO 13399

For the relationship between the symbols of this part of ISO 10889 and symbols according to ISO 13399 (all parts), see [Table A.1](#).

**Table A.1 — Relationship between symbols in this part of ISO 10889 and ISO 13399**

Symbol in this part of ISO 10889	Reference in this part of ISO 10889	Property name in ISO 13399	Symbol in ISO 13399	Reference in ISO 13399 (BSU code)
$d_1$	<a href="#">Figures 1 to 4</a>	connection diameter machine side	DCONMS	71EBDBF5060E6
$d_2$	<a href="#">Figures 1 to 4</a>	connection diameter workpiece side	DCONWS	7272379A5F325
$d_3$	<a href="#">Figures 1 and 3</a>	body diameter	BD	71ED6A9AF7D1D
$d_4$	<a href="#">Figure 1</a>	—	—	—
$d_5$	<a href="#">Figure 1</a>	—	—	—
$d_6$	<a href="#">Figures 1 to 4</a>	flange diameter	DF	71EC61D8A1771
$d_7$	<a href="#">Figures 2 and 3</a>	—	—	—
$d_8$	<a href="#">Figure 2</a>	body diameter	BD	71ED6A9AF7D1D
$d_9$	<a href="#">Figure 2</a>	—	—	—
$d_{10}$	<a href="#">Figure 3</a>	diameter lock nut	DLN	726E3E94711D9
$d_{11}$	<a href="#">Figure 4</a>	—	—	—
$d_{12}$	<a href="#">Figure 4</a>	—	—	—
$l_1$	<a href="#">Figure 1</a>	protruding length tool assembly length	LPR LTA	71DCD394BB20E 728B074A39EBC
$l_2$	<a href="#">Figure 1</a>	—	—	—
$l_3$	<a href="#">Figures 1 to 4</a>	flange thickness	FLGT	71EEF53809764
$l_4$	<a href="#">Figure 1</a>	—	—	—
$l_5$	<a href="#">Figure 1</a>	—	—	—
$l_6$	<a href="#">Figure 2</a>	protruding length tool assembly length	LPR LTA	71DCD394BB20E 728B074A39EBC
$l_7$	<a href="#">Figure 2</a>	—	—	—
$l_8$	<a href="#">Figure 3</a>	functional length	LF	71DCD39338974
$l_9$	<a href="#">Figure 3</a>	protruding length	LPR	71DCD394BB20E
$l_{10}$	<a href="#">Figure 4</a>	functional length tool assembly length	LF LTA	71DCD39338974 728B074A39EBC
$l_{11}$	<a href="#">Figure 4</a>	protruding length	LPR	71DCD394BB20E
$h_1$	<a href="#">Figures 1 to 4</a>	—	OAH <sup>a</sup> - RADH	—
$h_2$	<a href="#">Figures 1 to 4</a>	radial height	RADH	726E3E86B5284

<sup>a</sup> OAH is the "overall height" (code BSU 71D078EB73E87).

## Bibliography

- [1] ISO 8015, *Geometrical product specifications (GPS) — Fundamentals — Concepts, principles and rules*
- [2] ISO 13399 (all parts), *Cutting tool data representation and exchange*



