**Tool holders with cylindrical shank —
Part 3:
Type B with rectangular radial seat**

Porte-outil à queue cylindrique —

Partie 3: Porte-outil radial de type B



COPYRIGHT PROTECTED DOCUMENT

© ISO 2016, Published in Switzerland

All rights reserved. Unless otherwise specified, no part of this publication may be reproduced or utilized otherwise in any form or by any means, electronic or mechanical, including photocopying, or posting on the internet or an intranet, without prior written permission. Permission can be requested from either ISO at the address below or ISO's member body in the country of the requester.

ISO copyright office
Ch. de Blandonnet 8 • CP 401
CH-1214 Vernier, Geneva, Switzerland
Tel. +41 22 749 01 11
Fax +41 22 749 09 47
copyright@iso.org
www.iso.org

Contents

	Page
Foreword	iv
1 Scope	1
2 Normative references	1
3 Dimensions	1
4 Geometrical tolerances	8
5 Designation	8
6 Technical delivery conditions	9
6.1 General	9
6.2 Design	9
6.3 Scope of delivery	9
Annex A (informative) Relationship between designations in this part of ISO 10889 and ISO 13399	10
Bibliography	11

Foreword

ISO (the International Organization for Standardization) is a worldwide federation of national standards bodies (ISO member bodies). The work of preparing International Standards is normally carried out through ISO technical committees. Each member body interested in a subject for which a technical committee has been established has the right to be represented on that committee. International organizations, governmental and non-governmental, in liaison with ISO, also take part in the work. ISO collaborates closely with the International Electrotechnical Commission (IEC) on all matters of electrotechnical standardization.

The procedures used to develop this document and those intended for its further maintenance are described in the ISO/IEC Directives, Part 1. In particular the different approval criteria needed for the different types of ISO documents should be noted. This document was drafted in accordance with the editorial rules of the ISO/IEC Directives, Part 2 (see www.iso.org/directives).

Attention is drawn to the possibility that some of the elements of this document may be the subject of patent rights. ISO shall not be held responsible for identifying any or all such patent rights. Details of any patent rights identified during the development of the document will be in the Introduction and/or on the ISO list of patent declarations received (see www.iso.org/patents).

Any trade name used in this document is information given for the convenience of users and does not constitute an endorsement.

For an explanation on the meaning of ISO specific terms and expressions related to conformity assessment, as well as information about ISO's adherence to the WTO principles in the Technical Barriers to Trade (TBT) see the following URL: [Foreword - Supplementary information](#)

The committee responsible for this document is ISO/TC 29, *Small tools*, Subcommittee SC 2, *Holding tools, adaptive items and interfaces*.

This third edition cancels and replaces the second edition (ISO 10889-3:2004), of which it constitutes a minor revision, notably with the addition of [Annex A](#), which gives the relationship between the designations of this part of ISO 10889 and the ISO 13399 series.

ISO 10889 consists of the following parts, under the general title *Tool holders with cylindrical shank*:

- *Part 1: Cylindrical shank, location bore — Technical delivery conditions*
- *Part 2: Type A, shanks for tool holders of special designs*
- *Part 3: Type B with rectangular radial seat*
- *Part 4: Type C with rectangular axial seat*
- *Part 5: Type D with more than one rectangular seat*
- *Part 6: Type E with cylindrical seat*
- *Part 7: Type F with taper seat*
- *Part 8: Type Z, accessories*

Tool holders with cylindrical shank —

Part 3:

Type B with rectangular radial seat

1 Scope

This part of ISO 10889 specifies dimensions, designations, and complementary technical delivery conditions for tool holders with a rectangular radial seat of types B1 to B8 with cylindrical shank in accordance with ISO 10889-1.

ISO 10889 is applicable to tool holders with cylindrical shank for machine tools with non-rotating tools, preferably for turning machines.

For non-standardized tool holders with a rectangular radial seat such as the tool holders shown in the figures, it is advisable to apply the corresponding specifications of this part of ISO 10889.

2 Normative references

The following documents, in whole or in part, are normatively referenced in this document and are indispensable for its application. For dated references, only the edition cited applies. For undated references, the latest edition of the referenced document (including any amendments) applies.

ISO 2768-1, *General tolerances — Part 1: Tolerances for linear and angular dimensions without individual tolerance indications*

ISO 2768-2, *General tolerances — Part 2: Geometrical tolerances for features without individual tolerance indications*

ISO 10889-1, *Tool holders with cylindrical shank — Part 1: Cylindrical shank, location bore — Technical delivery conditions*

3 Dimensions

All dimensions and tolerances are given in millimetres. Tolerancing is done according to ISO 8015. Tolerances not specified shall be of tolerance class “m” in accordance with ISO 2768-1 and of class “H” in accordance with ISO 2768-2.

Unspecified details shall be chosen appropriately.

The dimensions of tool holders type B shall be in accordance with the dimensions shown in [Figures 1 to 8](#) and given in [Table 1](#).

The relationship between the symbols of this part of ISO 10889 and the symbols according to ISO 13399 is given in [Annex A](#).

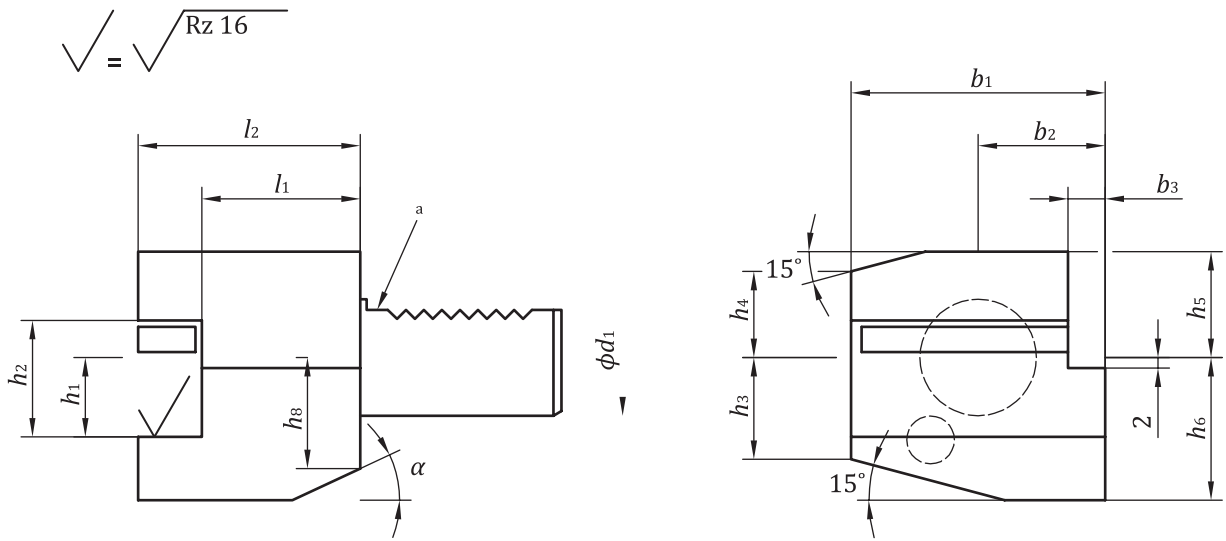

Key

a Cylindrical shank in accordance with ISO 10889-1.

NOTE Surface roughness is given in micrometres.

Figure 1 — Type B1 tool holder, right-hand, short

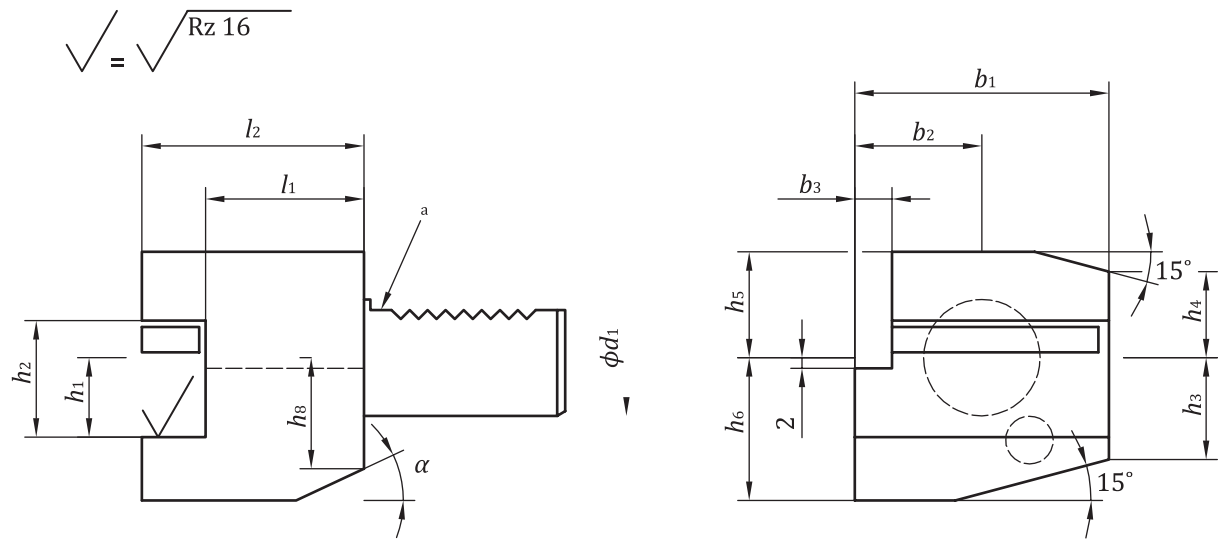

Key

a Cylindrical shank in accordance with ISO 10889-1.

NOTE Surface roughness is given in micrometres.

Figure 2 — Type B2 tool holder, left-hand, short

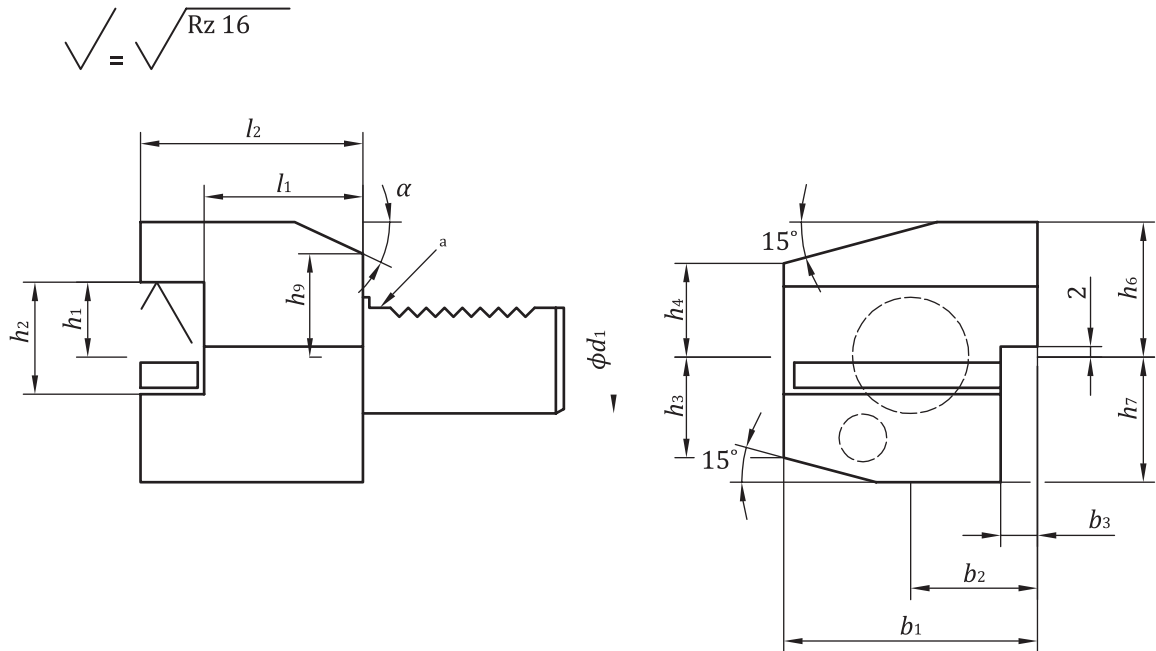

Key

a Cylindrical shank in accordance with ISO 10889-1.

NOTE Surface roughness is given in micrometres.

Figure 3 — Type B3 tool holder, overhead, right-hand, short

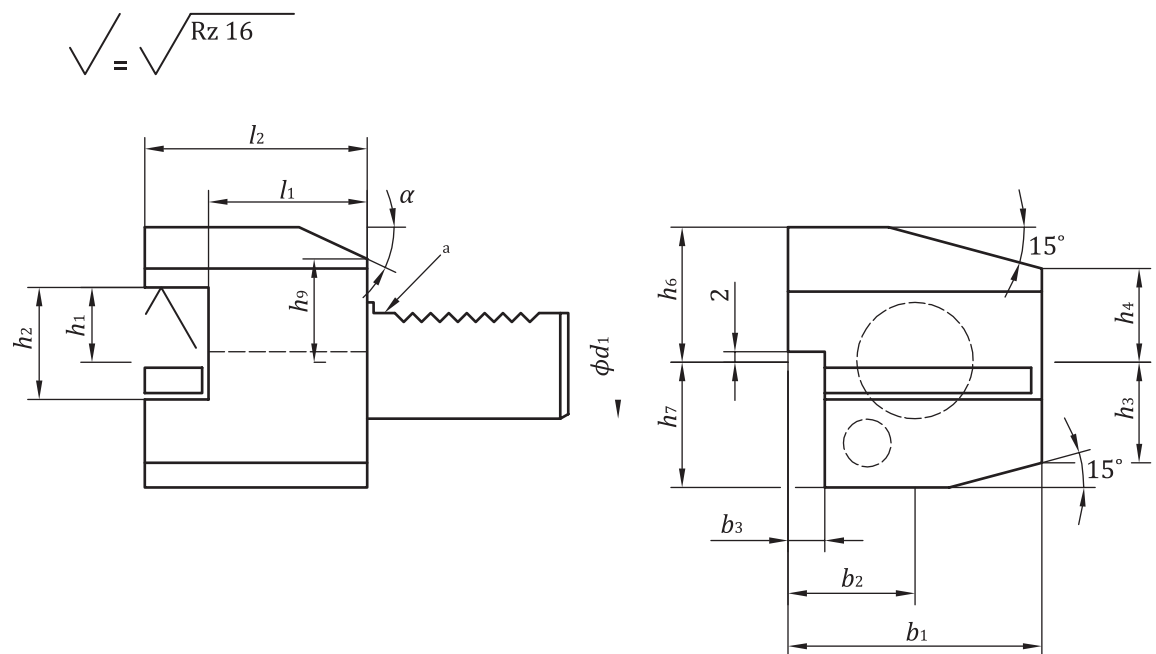

Key

a Cylindrical shank in accordance with ISO 10889-1.

NOTE Surface roughness is given in micrometres.

Figure 4 — Type B4 tool holder, overhead, left-hand, short

$$\sqrt{\quad} = \sqrt{Rz\ 16}$$

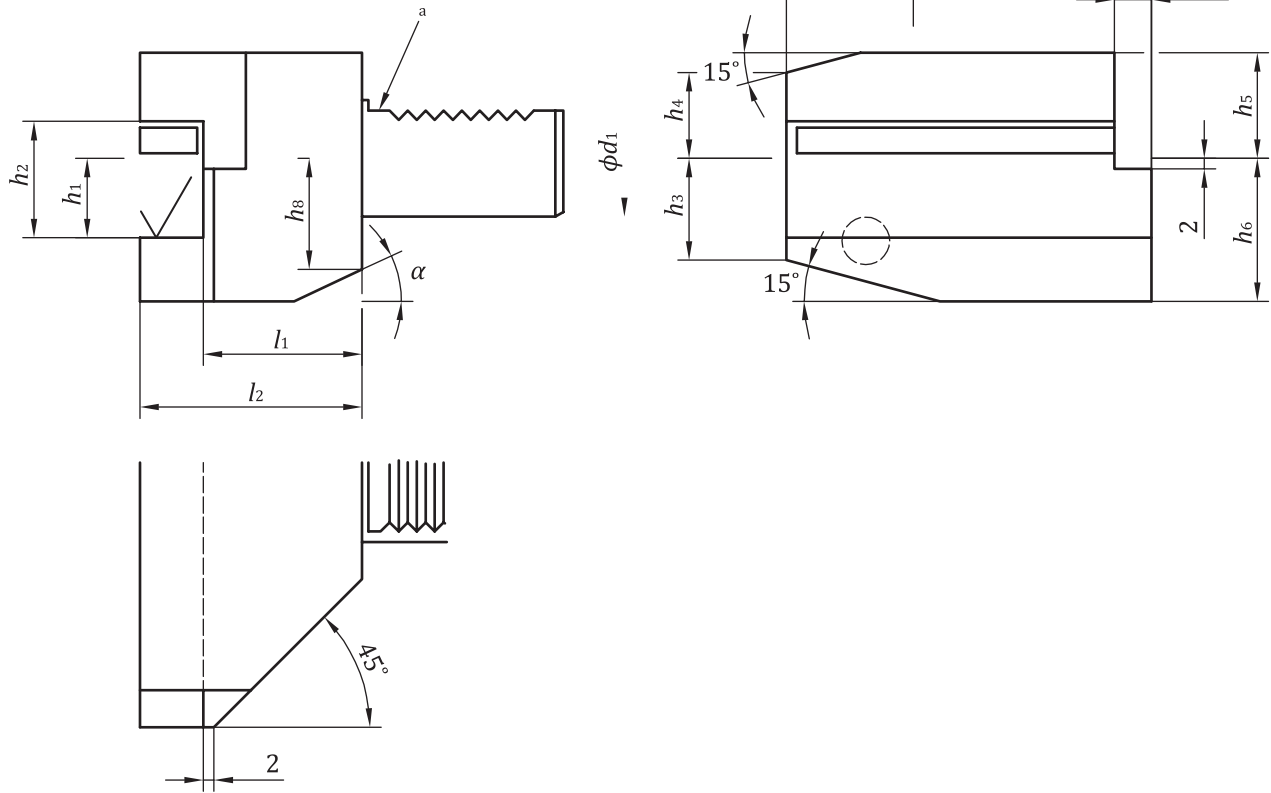

Key

a Cylindrical shank in accordance with ISO 10889-1.

NOTE Surface roughness is given in micrometres.

Figure 5 — Type B5 tool holder, right-hand, long

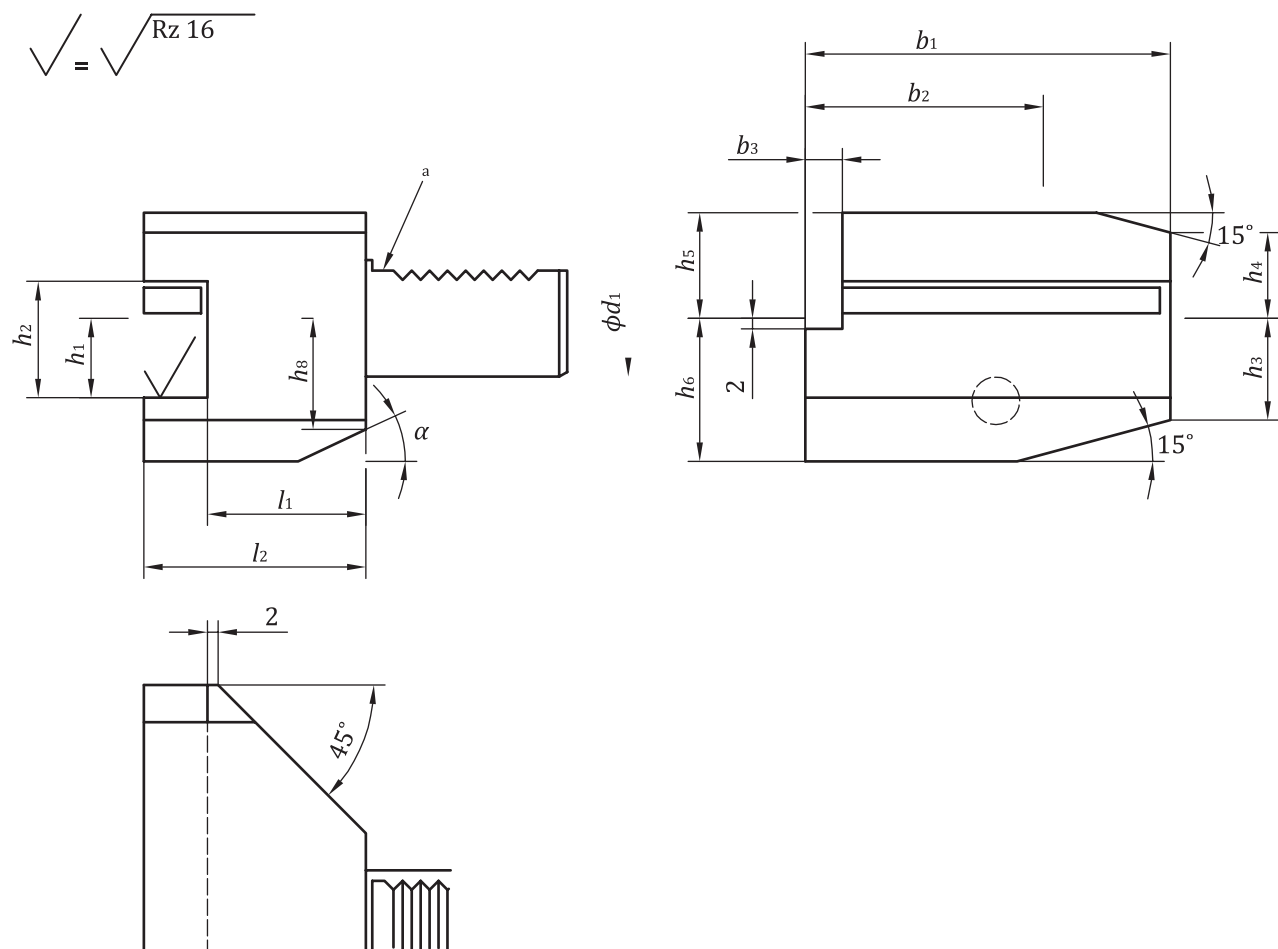

Key

a Cylindrical shank in accordance with ISO 10889-1.

NOTE Surface roughness is given in micrometres.

Figure 6 — Type B6 tool holder, left-hand, long

$$\sqrt{\quad} = \sqrt{Rz\ 16}$$

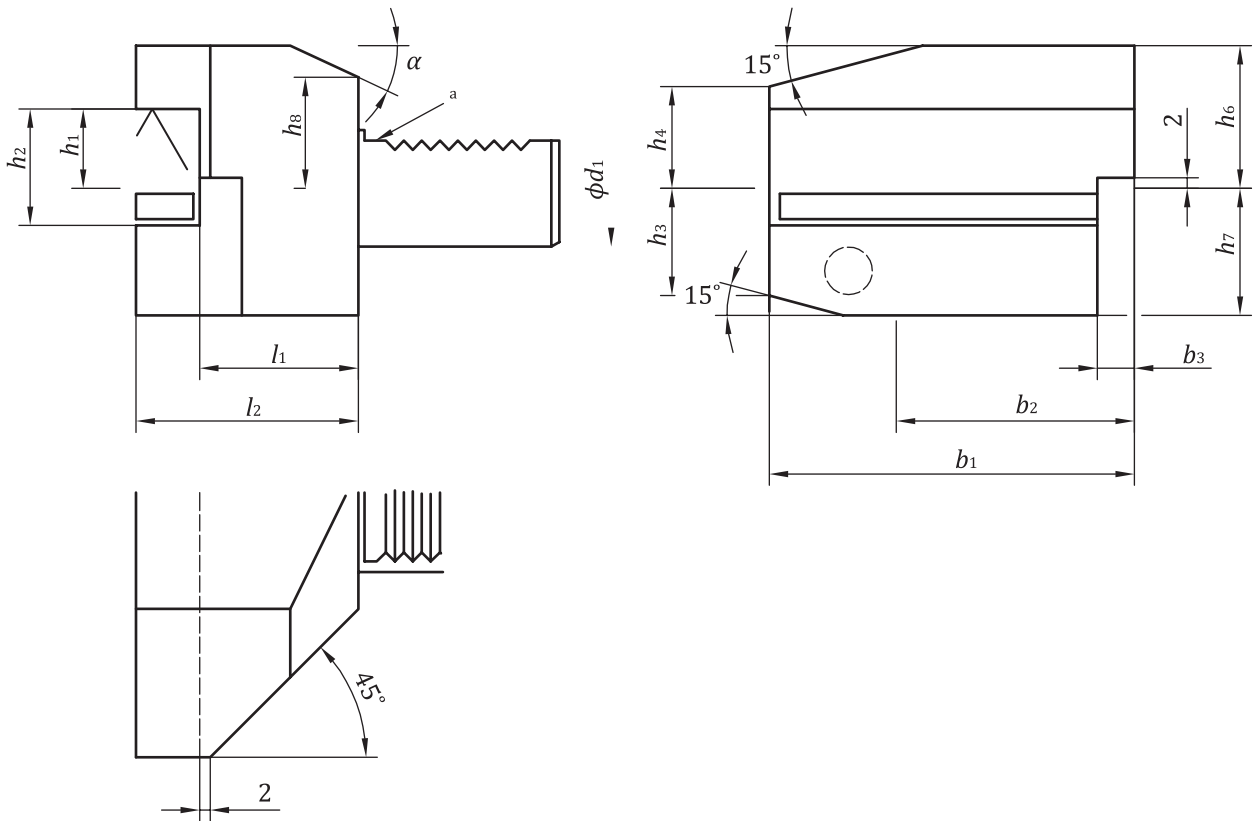

Key

a Cylindrical shank in accordance with ISO 10889-1.

NOTE Surface roughness is given in micrometres.

Figure 7 — Type B7 tool holder, overhead, right-hand, long

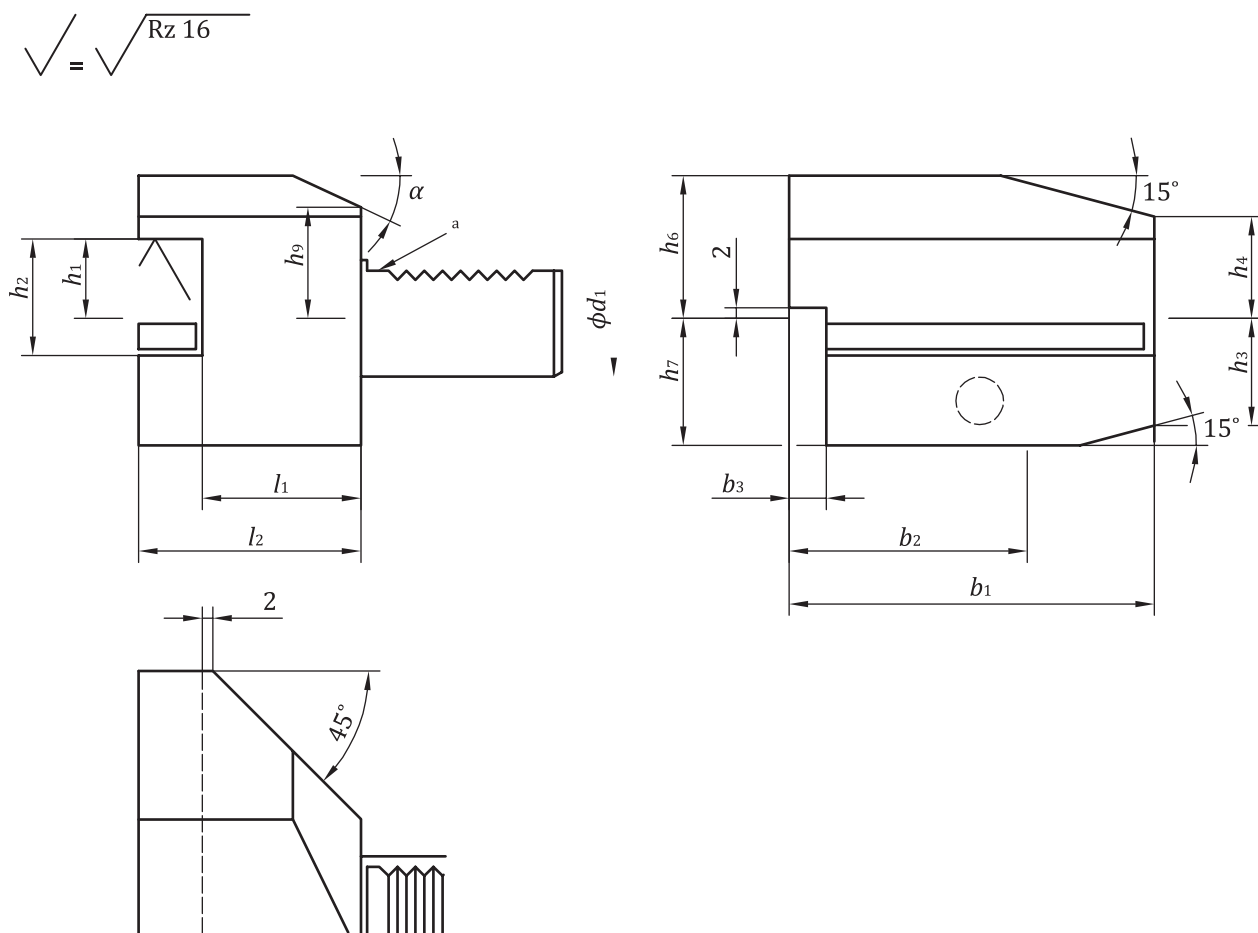

Key

a Cylindrical shank in accordance with ISO 10889-1.

NOTE Surface roughness is given in micrometres.

Figure 8 — Type B8 tool holder, overhead, left-hand, long

Table 1 — Type B tool holder dimensions

Dimensions in millimetres

d_1	b_1 Type B		b_2 Type B		b_3	h_1 0 -0,1	h_2 max.	h_3	h_4	h_5	h_6	h_7	h_8	h_9	l_1 +0,5 0	l_2	α
	1 to 4	5 to 8	1 to 4	5 to 8													
16	42	58	23	39	5	12	17	15	15	20	22	20	19	19	13 23	24 34	30°
20	55	75	30	50	7	16	22	19	19	25	30	25	23	23	16 26	30 40	30°
25	55	75	30	50	7	16	22	22,5	22,5	25	30	25	25	25	16 26	30 40	30°
30	70	100	35	65	10	20	29	26	22	28	38	35	30	28	22 42	40 60	25°
40	85	118	42,5	75,5	12,5	25	34	35	30	32,5	48	42,5	—	—	22	44	—
50	100	130	50	80	16	32	41	42	35	35	60	50	—	—	30	55	—
60	125	145	62,5	82,5	16	32	41	46	42,5	42,5	62,5	62,5	—	—	30	60	—
80	160	190	80	110	20	40	53	60	55	55	80	80	—	—	40	75	—

4 Geometrical tolerances

The geometrical tolerances shall be as defined in [Figure 9](#).

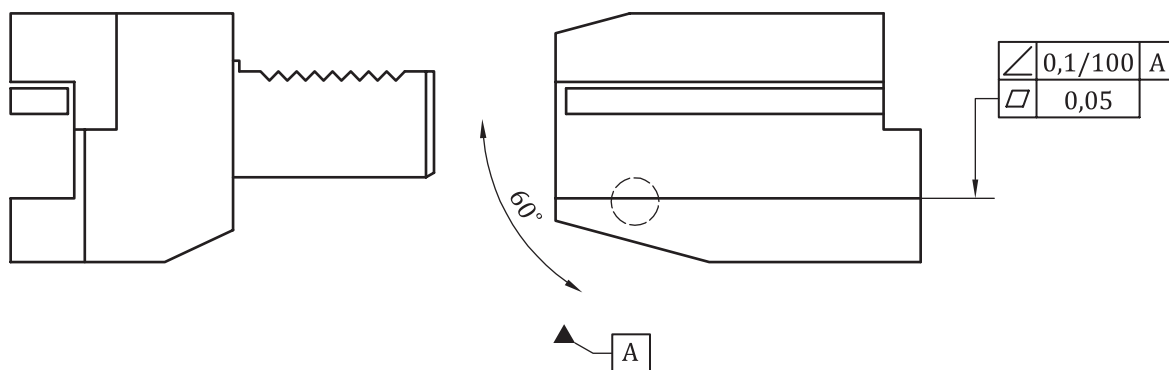

Figure 9 — Geometrical tolerances

5 Designation

A type B tool holder with rectangular radial seat in accordance with this part of ISO 10889 shall be designated by the following:

- “Tool holder”;
- reference to this part of ISO 10889, i.e. ISO 10889-3;
- type (B1, B2, B3, B4, B5, B6, B7, or B8);
- nominal diameter, d_1 , in millimetres;
- nominal height, h_1 , in millimetres;

f) head length, l_2 , in millimetres.

EXAMPLE A tool holder with rectangular radial seat of type B1 with a nominal diameter $d_1 = 60$ mm, a nominal height $h_1 = 32$ mm, and a head length $l_2 = 60$ mm is designated as follows:

Tool holder ISO 10889-3 - B1 - 60 × 32 × 60

6 Technical delivery conditions

6.1 General

As a complement to the requirements of ISO 10889-1, those given in 6.2 and 6.3 shall also apply.

6.2 Design

Tool holders with rectangular radial seat are equipped with a coolant outlet with adjustable direction. The design is at the discretion of the manufacturer, e.g. ball-type nozzle.

The tools shall be adjustable in the tool holder at right angles to the rectangular seat. The design is at the discretion of the manufacturer.

It shall be possible to reduce the dimension h_1 specified in Table 1 to the next smallest standardized dimension h_1 as given in Table 2. The design is at the discretion of the manufacturer.

Table 2 — Smaller standardized dimension h_1

Dimensions in millimetres

d_1	16	20	25	30	40	50	60	80
h_1	10	12	12	16	20	25	25	32

Tool holders may also be supplied with a hardened contact surface. Then it shall be mentioned in the designation (H for hardened contact surface).

EXAMPLE A tool holder with rectangular radial seat of type B1 with a nominal diameter $d_1 = 40$ mm, a nominal height $h_1 = 20$ mm, and a head length $l_2 = 44$ mm with hardened contact surface is designated as follows:

Tool holder ISO 10889-3 - B1 - 40 × 20 × 44 H

6.3 Scope of delivery

The scope of delivery of tool holders includes clamping elements for the clamping of the tools. The design of the clamping elements is at the discretion of the manufacturer.

Annex A (informative)

Relationship between designations in this part of ISO 10889 and ISO 13399

For the relationship between the symbols of this part of ISO 10889 and symbols according to ISO 13399, see [Table A.1](#).

Table A.1 — Relationship between symbols in this part of ISO 10889 and ISO 13399

Symbol in this part of ISO 10889	Reference in this part of ISO 10889	Property name in ISO 13399	Symbol in ISO 13399	Reference in ISO 13399 (BSU code)
d_1	Figures 1 to 8	connection diameter machine side	DCONMS	71EBDBF5060E6
b_1	Figures 1 to 8	overall width	OAW	71CF299257986
b_2	Figures 1 to 8	radial width	RADW	726E3E8DA5589
b_3	Figures 1 to 8	Radial offset width	RADWOF	726E3E8E0AE97
l_1	Figures 1 to 8	functional length	LF	71DCD39338974
l_2	Figures 1 to 8	protruding length	LPR	71DCD394BB20E
h_1	Figures 1 to 8	functional height	HF	71CF29994E737
h_2	Figures 1 to 8	—	—	—
h_3	Figures 1 to 8	radial height chamfer distance lower	RHCDL	726E3E8F925AC
h_4	Figures 1 to 8	radial height chamfer distance upper	RHCDU	726E3E9005480
h_5	Figures 1 to 8	—	OAH ^a – RADH	—
h_6	Figures 1 to 8	radial height	RADH	726E3E86B5284
h_7	Figures 1 to 8	—	OAH ^a –RADH	—
h_8	Figures 1 to 8	—	—	—
h_9	Figures 1 to 8	—	—	—
2	Figures 1 to 8	Radial offset height	RADHOF	726E3E8AF37E4
15°	Figures 1 to 8	radial height chamfer angle lower	RHCAL	726E3E8E6CEE3
15°	Figures 1 to 8	radial height chamfer angle upper	RHCAU	726E3E8F2AE05

^a OAH is the “overall height” (code BSU 71D078EB73E87).

Bibliography

- [1] ISO 8015, *Geometrical product specifications (GPS) — Fundamentals — Concepts, principles and rules*
- [2] ISO 13399 (all parts), *Cutting tool data representation and exchange*

