**Water quality — Guidelines for the
selection of sampling methods and
devices for benthic macroinvertebrates
in fresh waters**

*Qualité de l'eau — Lignes directrices pour la sélection des méthodes
et des dispositifs d'échantillonnage des macro-invertébrés benthiques
dans les eaux douces*





COPYRIGHT PROTECTED DOCUMENT

© ISO 2012

All rights reserved. Unless otherwise specified, no part of this publication may be reproduced or utilized in any form or by any means, electronic or mechanical, including photocopying and microfilm, without permission in writing from either ISO at the address below or ISO's member body in the country of the requester.

ISO copyright office
Case postale 56 • CH-1211 Geneva 20
Tel. + 41 22 749 01 11
Fax + 41 22 749 09 47
E-mail copyright@iso.org
Web www.iso.org

Published in Switzerland

Contents

Page

Foreword	iv
Introduction	v
1 Scope	1
2 Terms and definitions	1
3 Principle	2
3.1 General	2
3.2 Objectives	2
3.3 Sampling programmes	3
3.4 Device and method selection	3
4 Benthic macroinvertebrates sampling methods and devices	3
4.1 General	3
4.2 Handnet	3
4.3 Surber sampler	7
4.4 Box sampler	9
4.5 Cylinder sampler	11
4.6 Naturalist's dredge	12
4.7 Ekman-Birge grab	14
4.8 Ponar grab	15
4.9 Van Veen grab	16
4.10 Polyp grab (orange peel grab)	18
4.11 Air-lift sampler	19
4.12 Core and tube samplers	22
4.13 Colonization samplers	23
Bibliography	26

Foreword

ISO (the International Organization for Standardization) is a worldwide federation of national standards bodies (ISO member bodies). The work of preparing International Standards is normally carried out through ISO technical committees. Each member body interested in a subject for which a technical committee has been established has the right to be represented on that committee. International organizations, governmental and non-governmental, in liaison with ISO, also take part in the work. ISO collaborates closely with the International Electrotechnical Commission (IEC) on all matters of electrotechnical standardization.

International Standards are drafted in accordance with the rules given in the ISO/IEC Directives, Part 2.

The main task of technical committees is to prepare International Standards. Draft International Standards adopted by the technical committees are circulated to the member bodies for voting. Publication as an International Standard requires approval by at least 75 % of the member bodies casting a vote.

Attention is drawn to the possibility that some of the elements of this document may be the subject of patent rights. ISO shall not be held responsible for identifying any or all such patent rights.

ISO 10870 was prepared by Technical Committee ISO/TC 147, *Water quality*, Subcommittee SC 5, *Biological methods*.

This first edition of ISO 10870 cancels and replaces ISO 7828:1985, ISO 8265:1988, and ISO 9391:1993, which have been technically revised.

Introduction

Macroinvertebrates are an important component of fresh-water ecosystems and are the most widely used biological group to monitor aquatic ecological status (Reference [6]). A wide range of sampling and survey methodologies has been developed for a variety of specific applications as well as ecological assessment including: conservation status, biodiversity assessment, pollution control, and habitat enhancement (Reference [7]).

This International Standard gives guidelines on the selection, design, operation, and performance characteristics of sampling devices for the evaluation of benthic macroinvertebrate taxonomic composition, abundance, and diversity in fresh waters, which can all be components of the applications given in the first paragraph.

© ISO 2012

Water quality — Guidelines for the selection of sampling methods and devices for benthic macroinvertebrates in fresh waters

WARNING — Working in or around water is inherently dangerous. This International Standard does not purport to address the safety problems associated with its use. It is the responsibility of the user to establish appropriate health and safety practices and to ensure compliance with any national regulatory conditions.

1 Scope

This International Standard specifies criteria for the selection of sampling methods and devices (operation and performance characteristics) used to evaluate benthic macroinvertebrate populations in fresh waters (rivers, canals, lakes, and reservoirs). The methods and devices considered in this International Standard are suitable for sampling all major components of the benthic assemblage. They are not suitable for sampling meiofauna.

2 Terms and definitions

For the purpose of this document, the following terms and definitions apply.

2.1

abundance

total number of individuals in a taxon, per sampling unit or estimated per unit area

2.2

benthic

dwelling at the bottom of an aquatic environment

2.3

canal

artificial watercourse constructed, usually, to join rivers, lakes or seas, and often of a size suitable for navigation

[SOURCE: ISO 6107-2:2006,^[2] 15]

2.4

deep water

water from 1 m below the water surface to the limiting depth for efficient sampling

2.5

diversity

species richness of a community and the distribution of individuals across those species

2.6

habitat

area of the environment in which a particular organism or population lives, including its characteristic assemblages of plants and animals

2.7

lake

inland body of water of considerable area

[SOURCE: ISO 6107-2:2006,^[2] 57]

2.8

macroinvertebrate

invertebrate that is easily visible without magnification (>0,5 mm)

2.9

meio-fauna

small benthic invertebrates that pass unharmed through a 0,5 mm mesh

2.10

qualitative observation

observation that does not involve measurement or numbers

2.11

quantitative observation

observation that involves measurement or numbers

2.12

reservoir

construction, partially or wholly man-made, for storage and/or regulation and control of water

[SOURCE: ISO 6107-2:2006,^[2] 107]

2.13

river

natural body of water flowing continuously or intermittently along a well-defined course into an ocean, sea, lake, inland depression, marsh or other watercourse

[SOURCE: ISO 6107-2:2006,^[2] 109]

2.14

semi-quantitative observation

observation on a sample where the relative abundance of taxa can be estimated, but not numerically related to a specific area or volume of habitat

2.15

species/taxa composition

species/taxa list from the sampled habitat which can include the relative dominance (number of benthic macroinvertebrates of a species/taxon divided by the total number of benthic macroinvertebrates of all species/taxa, expressed as a percentage)

3 Principle

3.1 General

In order to evaluate benthic macroinvertebrate population parameters such as taxonomic composition, abundance, and diversity in fresh waters, appropriate sampling devices are required. The choice of the appropriate sampling device depends on the objective of the study itself as well as on the water type and the benthic macroinvertebrate population being studied (Reference [6]).

Sampling methods are described in this International Standard to cover the broad variety of fresh waters and the diversity of macroinvertebrate taxa and these habitats. The performance characteristics of the devices should be taken into account in order to achieve the best evaluation in the context of the objectives of the survey.

3.2 Objectives

The methods given in this International Standard are suitable for a wide variety of objectives. These objectives include: assessment of ecological status, detection of change in surveillance, operational and investigational monitoring programmes, diagnosis of environmental stress, and the assessment of both acute and chronic stressors (pollution control). The methods are also suitable for conservation and biodiversity assessments with measurement of both community parameters and appraisal of rare species status. Many of the methods are used both routinely and in research studies (References [6][11]–[14]). Guidance on the analysis of results from benthic macroinvertebrate surveys is given in ISO 8689-1^[3] and ISO 8689-2.^[4]

3.3 Sampling programmes

The design of a sampling programme depends on the aims of the survey and the required power of discrimination of the data. The programme should be developed with regard to the local topographical and hydrological conditions in the survey area, information on local environmental stressors, and knowledge from previous surveys (if any). The number of sampling stations, their positions, season or seasons of sampling, and the numbers of replicate samples to be taken at each station should be established prior to the initiation of the survey, or through a pilot survey (Reference [6]). The design of the programme determines the options for data treatment and statistical analyses that can be performed; therefore, prior consideration should be accorded to the reporting requirements. Quality assurance of sampling and analysis should also be considered at this stage. Further general guidance on survey design is given in ISO 5667-1.^[1]

During the design of the sampling programme, consideration should be given to the possibility of transferring diseases (e.g. crayfish plague) and the dispersal of non-native invasive species. Appropriate precautionary measures should be included in the operation of any of the devices to prevent such transfers.

3.4 Device and method selection

The methods and devices given in this International Standard have been chosen to achieve a good evaluation for the broad variety of inland waters and the diversity of macroinvertebrate taxa. The methods and devices are suitable for routine monitoring and for some research purposes. Methods and devices suitable only for research purposes have been excluded. Detailed guidance on the design of sampling equipment, the mode of operation and the scope of characteristics can be found in Clause 4. Three main selection criteria have been evaluated in recommending suitable methods/devices for sampling different habitats. The three criteria are:

- suitability for operation in flowing or standing fresh waters;
- suitability for operation in shallow or deep fresh waters;
- the ability to provide results that are qualitative, quantitative or semi-quantitative.

Table 1 indicates which devices are appropriate for each habitat and in which section each device can be found.

4 Benthic macroinvertebrates sampling methods and devices

4.1 General

Benthic macroinvertebrates may be caught by active sampling or passive sampling (colonization samplers). For all sampling methods, seasonal aspects of macroinvertebrate life cycles should be considered and taken into account. The efficiency of active and passive sampling may also vary depending on the time (day/night) of use; therefore the details of these aspects of use should be recorded. For those sampling devices that use nets, it is important to consider mesh size in relation to the objectives of the survey. General comments about mesh sizes applicable to all devices using nets are given in Table 2. The performance characteristics of each sampling device can be found at the end of each section.

4.2 Handnet

4.2.1 General

No sampling technique is appropriate to all types of water and it is necessary to specify a number of sampling procedures to meet different requirements. Sampling effort should be appropriate to the objectives of the study and consideration of the physical characteristics of the site, and hence be based on suitable distance, area or time (Reference [15]).

Sampling during and immediately after spates should be avoided (unless investigating the impacts of floods). Samples collected at these times are not comparable with samples collected during periods of normal flow and it is possible that they do not reflect the underlying environmental quality of the site accurately.

Table 1 — Selection of devices for specific environments

Equipment	Clause	Water				Sample type		
		Still	Flowing	Deep	Shallow	Qualitative	Semi-quantitative	Quantitative
Handnet	4.2	✓	✓	✓ ^a	✓	✓	✓	—
Surber	4.3	—	✓	—	✓	✓	✓	✓
Box	4.4	—	✓	—	✓	✓	✓	✓
Cylinder	4.5	—	✓	—	✓	✓	✓	✓
Naturalist's dredge	4.6	✓	✓	✓	—	✓	✓	—
Eckman–Birge	4.7	✓	✓	✓	✓	✓	✓	✓
Ponar grab	4.8	✓	✓	✓	—	✓	✓	✓
Van Veen grab	4.9	✓	✓	✓	—	✓	✓	✓
Polyp grab	4.10	✓	✓	✓	—	✓	✓	✓
Air lift sampler	4.11	✓	✓	✓	—	✓	✓	✓
Core and tube samplers	4.12	✓	✓	✓	—	✓	✓	✓
Colonization samplers	4.13	✓	✓	✓	✓	✓	✓	—

✓ ≡ suitable — ≡ not suitable ^a Maximum 4 m.

4.2.2 Frame design

A handnet consists of a handle and a frame, which holds a net in which organisms are collected. The handles are usually made of metal, wood or reinforced plastic and the frames are usually constructed in metal. A rectangular frame (see Figure 1) is preferred so the flat edge can be placed in close contact with the bed during use. The vertical sides permit a larger cross-sectional area of water to enter the net than a triangular shape does.

The handnet frame should be large enough to allow a reasonable sample to be taken, but not so large that the net offers too much resistance to the flow of water, which could make sampling difficult in fast flows. The length of the net can be varied depending on the objective of the study. Suitable rectangular handnets currently in use have evolved in the light of experience and have frame dimensions in the ranges listed in Table 2.

Table 2 — Handnet frame dimensions

Dimension	mm
Width, <i>b</i>	200 to 400
Depth, <i>d</i>	400 to 500
Shoulder, <i>d_s</i>	100 to 200
Height, <i>h</i>	200 to 300

4.2.3 Net design

In choosing an appropriate net, two interrelated factors have to be considered; the dimensions and shape of the net; and the mesh size of the net material. Finer mesh sizes increase the risk of clogging with organisms and debris. This reduces net efficiency as it increases the tendency of water and organisms to flow around the net rather than into it. This effect can be minimized by increasing the depth of the net (see Figure 1, depth *d*), or by frequently emptying it. For guidance, Table 3 gives examples of the most suitable depths of nets as a function of their size of openings. The shape of the net is not particularly important from a sampling point of view but can be determined by practical considerations in manufacture. The net material is normally sewn to strong canvas, which is attached to an inner frame. This material is more resistant to abrasion. Methods of joining the inner and main frames, which facilitate replacement in the field, are clearly advantageous. Net

material may be of a monofilament weave or knitted. However, monofilament is preferred due to its increased strength. Synthetic fibre is preferable since it is stronger and less liable to decompose, but should be selected to ensure sufficient flexibility. The mesh size should be appropriate for the objectives of the study. Increasing the net mesh size decreases estimates of abundance and taxa richness. The maximum recommended mesh opening sizes are given in Table 3.

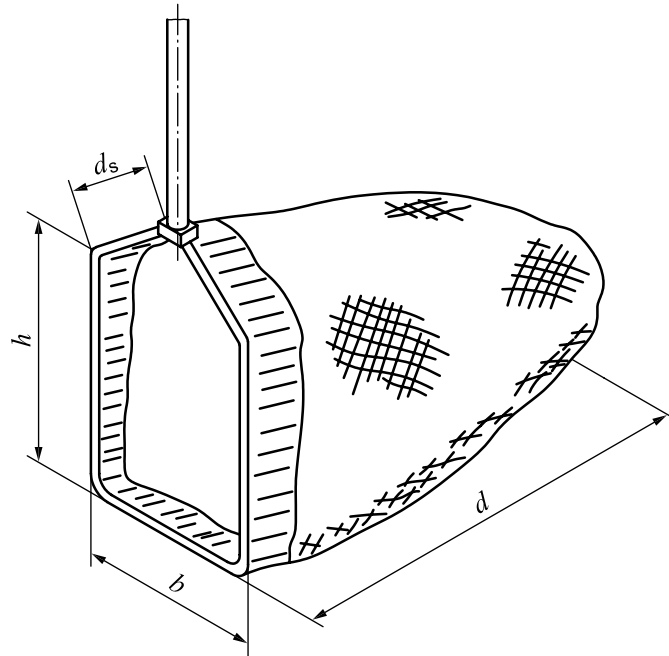

Key

- b width
- d depth
- d_s shoulder
- h height

Figure 1 — A rectangular handnet

4.2.4 Handnet operation

4.2.4.1 General comments

When it is intended to collect as many taxa as possible, take a sample by a combination of the methods. It is customary to explore thoroughly all the types of substratum by this method to assess ecological status, including sweeps through weed patches and between the roots of overhanging trees.

Examine and wash the collecting net before and after samples are taken. Take care to ensure that the net is not damaged or contaminated with animals from previous samples.

4.2.4.2 Kick sampling

The net should be held vertically on the riverbed downstream of the operator's feet with the lower edge held against the substrate. The substratum should be disturbed forcefully with the toe or heel of the boot and the released material should be caught in the net. By working across the river, different habitats can be sampled. This method is somewhat selective, because it is possible that fewer of the attached animals are taken than unattached fauna, therefore some of the stones should be lifted and examined by hand where practical. To allow semi-quantitative results to be calculated, the kick sample needs to be based on an agreed time or an agreed area. Recommended times are between 2 min and 5 min to achieve a reasonable sample for routine ecological status assessment (EN 16150^[5]). EN 16150^[5] gives guidance on replicate sampling with

the handnet. Conservation and biodiversity studies designed to catch maximum numbers of taxa can require longer sampling times.

The removal of the catch can be facilitated by using the flowing water to wash it into a corner of the net and then shaking the net gently while removing it from the water. The net can then be turned inside out to aid the transfer of the sample to a container of water. Animals which cling to the net can be removed by hand and then added to the sample. It is recommended that the net be thoroughly washed between taking samples. Further sample treatment, such as the decanting of surplus water (to minimize predation by carnivores), the reduction of sample bulk by removing sticks, stones, leaves, and other debris as well as the addition of preservatives, depend upon operator preference and the objective of the sampling programme. A sieve, of the same mesh size as the net, can be used to reduce sample bulk.

Table 3 — Recommended handnet mesh sizes and nets depths

Survey objective	Maximum size of mesh opening mm	Recommended minimum depth mm	Comments
General/routine	0,5 to 1,0	400	Danger that small stages of most benthos are not captured
Biological monitoring: data for surveys using biotic scores or indices			
For surveillance with more complete records of taxa present, diversity indices	0,5	450	Danger that early instar stages of many insects are not captured
For special surveys requiring complete taxa lists including rare taxa for conservation evaluation	0,25	550	Ensures capture of first instar stages and very small organisms which may prove of value in water quality determination

4.2.4.3 Sampling in very shallow flowing water by hand

Hold the lower edge of the handnet against the streambed while turning over the stones immediately upstream by hand in the flowing water. Dislodged animals are carried into the net by the current. Examine the stones, remove any attached or clinging species and add them to the sample. Disturb the finer lower deposits to dislodge any further organisms.

4.2.4.4 Sampling in slow-flowing or still waters

In still water, it is possible that the handnet is not the most appropriate method for sampling because of the requirement for flow to sweep the macroinvertebrates into the net. Consideration should be given to the use of other methods and devices (Table 1). Some habitats, such as stony lake shores, can be sampled by the hand-picking method, but this can cause collecting efficiency to be lower. The best procedure is to remove stones carefully and agitate them vigorously in the net, after which any remaining animals can be picked off by hand and added to the sample. When sampling other slow-flowing or still-water habitats, the absence or reduction of water movement necessitates a different procedure from that used in flowing water where the current is used in order to sweep dislodged animals into the net. In still water, it is necessary for the operator to supply the relative motion of the fauna and net. The substratum should be disturbed with the feet and the dislodged fauna caught by repeatedly sweeping the net through the water in the disturbed area.

4.2.4.5 Sampling in deep waters

In deep-flowing and still water, where the substratum consists of mud or silt, the handnet should be drawn or pushed through the surface layer of the substratum, preferably over a predetermined area or distance. The limit of deep-water sampling relates to the length of the handle: 2 m is most often used and 4 m is probably the practical limit.

4.2.4.6 Sampling surface-dwelling macroinvertebrates

The handnet is a very effective way of collecting surface-dwelling macroinvertebrates. In timed samples, part of the time should be used to collect these animals; it is possible that the operator needs actively to seek them out — stands of vegetation, in particular, can require sweeping with the net at the surface of the water. For conservation and biodiversity studies, again active sampling at the surface with the net is required.

4.2.5 Performance characteristics

Performance characteristics for the handnet are given in Table 4.

Table 4 — Performance characteristics for the handnet sampler

Habitat sampled	Comment
Vegetation	Good for sweeping through macrophytes and sampling areas with roots
Shallow water	Excellent
Deep water	Limited to 4 m handle
Soft substrate	Suitable for soft substrates
Hard substrate	Suitable for hard substrates
Collection of surface-dwelling macroinvertebrates	Excellent. This is the only active method suitable for the collection of surface-dwelling macroinvertebrates [e.g. Gerridae (pond skaters)]
Data type	Qualitative/semi-quantitative

4.3 Surber sampler

4.3.1 Frame design

The sampler consists of two frames hinged together, one supporting the net and the other defining the sampling area. The whole sampler weighs about 2 kg, folds flat and is easy to carry. Each frame, and therefore the sampling area, is usually a square of dimension 200 mm × 250 mm or 333 mm × 333 mm (to give a sampling area and a net mouth of approximately 0,05 m² or 0,1 m²). Two braces lock the two frames into the working position at right angles to each other. The two triangular wings of netting or canvas reduce the loss of invertebrates around the sides of the net (see Figure 2).

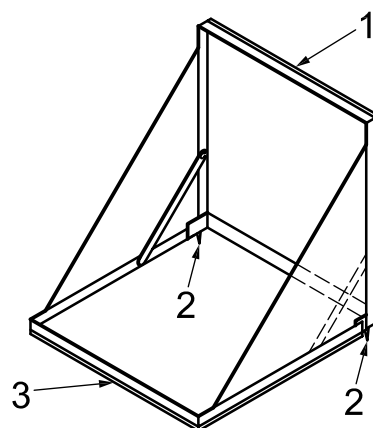

Key

- 1 support for the net
- 2 spike
- 3 polychloroprene skirt

Figure 2 — Schematic diagram for a Surber sampler frame

4.3.2 Net design

The net depth should be in line with the recommendations given in Table 3, with a collar of heavier material (e.g. canvas or sail-cloth) which reinforces a short area around the mouth of the net. This collar increases the durability of the net, and can be extended under the net to protect it from abrasion. Originally, the nets were tapered slightly to a dome-shape at the rear end, but pocket-shaped and cone-shaped nets are now frequently used (see comment on net design in 4.2.3).

4.3.3 Surber sampler operation

After the net has been opened and the side braces secured, the first sampling position should be selected and approached from downstream. The sampler should be lowered into the water with the open end upstream (the net is kept open by the current). The open quadrat frame should be placed firmly on the bed to define the sampling area.¹⁾ The operator should stand behind the sampler with feet astride the collecting net and knees resting on the upper part of the frame to which the net is attached. This position is convenient for the operator and also keeps the lower frame pressed against the substrate.

The substrate within the quadrat should be disturbed carefully by hand. Large stones should be scrubbed clean and discarded. Depending on the substrate, small stones and gravel should be stirred and turned over to a depth of between 50 mm and 100 mm. It is important to ensure that all dislodged materials enter the net.

With a lightweight surber sampler, one hand is usually required to hold the sampler in place.²⁾ It is essential that this sampler be used by two operators in water of high current velocity ($>0,8 \text{ ms}^{-1}$), one to hold the sampler and the other to disturb the substrate.

When no more material can be dislodged within the quadrat, the sampler should be lifted out of the water with the open end of the net facing upstream. The net may be immersed in the water to wash the materials in the net to its apex, but it is essential that the mouth of the net not be resubmerged (to prevent additional animals entering the net). The net should be turned inside out and its contents transferred to a container, such as a tray, bowl or jar, which holds water collected from the water body being sampled. Some operators insert a collecting bottle at the apex of the sampling net. Some preliminary sorting can be performed in the field to remove unwanted debris (e.g. wood fragments and rocks), and to minimize sample mass. This can be further enhanced by using a small net together with a decanting technique (i.e. swirling the contents of the container and pouring into the small net, and repeating this operation until all the organic material together with the invertebrates have been transferred to the small net). The small net should then be everted so that the contents can be transferred to a sample container. The remaining inorganic material should be inspected and any visible organisms transferred to the sample. For quantitative results, the sample should be preserved immediately to avoid underestimation of the numbers.

4.3.4 Performance characteristics

Performance characteristics for the Surber sampler are given in Table 5.

1) Gaps beneath the edge of the quadrat frame can be quickly filled with gravel to prevent the loss of invertebrates under the frame when the substrate within the quadrat is disturbed. Fastening a skirt of foam rubber (polychloroprene) to the lower frame enables a tighter fit between the sampler and the substrate. The frame can be further secured to the substrate by mounting two small spikes in the corner where the frames are connected.

2) A handle for maintaining the frame in place on the substrate can be screwed into a central brass T on the top of the upright frame. The handle can be modified to fit against the chest of the operator, who can thus press the lower quadrat frame against the substrate, a technique that is especially useful at high current velocities. Alternatively, two extensions may be attached to the lower corners of the vertical frame. These can be folded out so that they lie flat on the bed, thereby allowing the operator to maintain the sampler in place with his feet.

Table 5 — Performance characteristics for the Surber sampler

Habitat sampled	Comment
Vegetation	Of limited use in vegetation stands
Shallow water	Performance is dependent on flow — therefore of limited use in slow and still waters
Deep water	Application in deep water is limited due to poor accessibility and limited visibility when the water is turbid
Soft substrate	Suitable for soft substrates
Hard substrate	Suitable for hard substrates — see boulders/bedrock
Boulders/bedrocks	Cannot be used
Collection of surface-dwelling macroinvertebrates	Not suitable for the collection of surface-dwelling organisms
Data type	Qualitative/semi-quantitative/quantitative

4.4 Box sampler

4.4.1 Design

A stronger construction of a Surber sampler is the box sampler which is illustrated in Figure 3. This structure replaces the two frames with a box. The box has an open bottom and top, solid sides, a net on the downstream side, and a screen on the upstream side (to prevent the entry of drift organisms). The use of the box minimizes the loss of invertebrates and also gives the sample additional strength and stability, which can be of particular use when operating in high current velocities.

4.4.2 Operation

The box sampler is operated in a similar way to the Surber sampler (4.3.3). The sampling position should be approached from downstream to avoid undue disturbance of the sampling area. The sampler should be placed on the streambed so that the water inlet screen faces the current. The box should be pushed, where possible, into the substrate to a maximum depth of 70 mm (using an alternating rotary motion). The collecting net should be arranged so that it is fully open and extends downstream of the cylinder. This permits an unimpeded flow of water through the net. The operator should stand immediately downstream of the sampler with feet astride the collecting net, using both feet and legs to maintain the position of the sampler.

The advantage of this sampler is its ability to be used over stands of macrophytes and the fact that it allows the operator to collect the macroinvertebrates associated with the vegetation as well as those in the benthos itself.

It can be deployed in static water if the hands are used to wash organisms into the net.

4.4.3 Performance characteristics

Performance characteristics for the box sampler are given in Table 6.

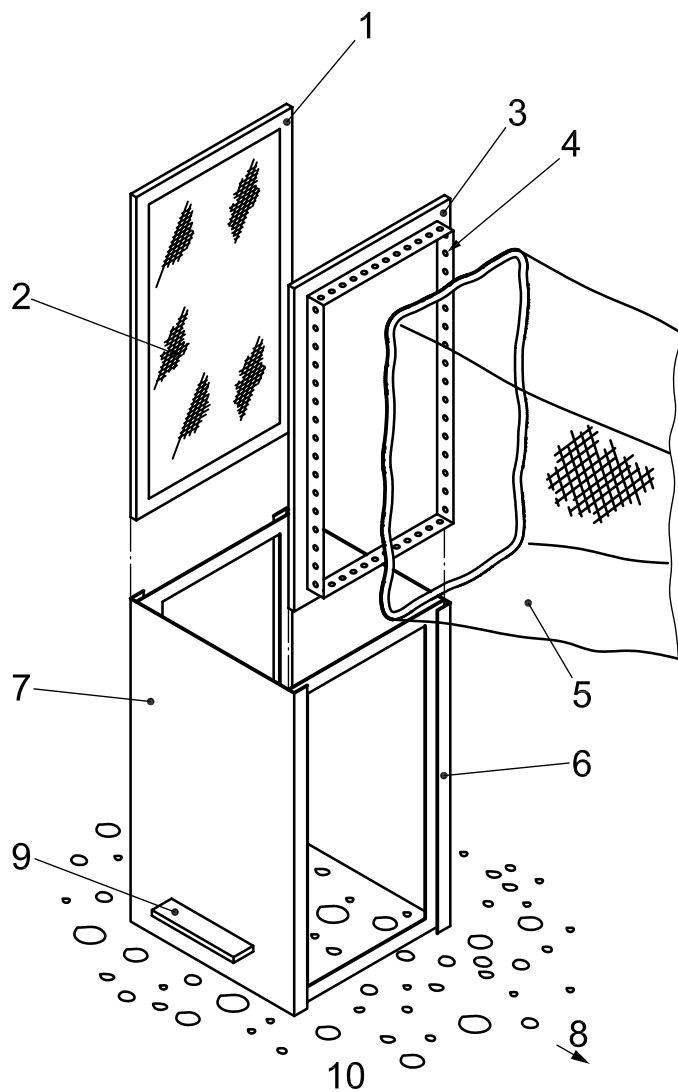

Key

- 1 front-frame galvanized steel
- 2 wire gauze
- 3 rear-frame galvanized steel
- 4 holes for net attachment using thin wire
- 5 net
- 6 main sampler unit
- 7 solid side panel
- 8 flow
- 9 metal flange
- 10 riverbed

Figure 3 — A schematic diagram of a box sampler

Table 6 — Performance characteristics for the box sampler

Habitat sampled	Comment
Vegetation	Designed to be used over vegetation stands, can be used to collect macroinvertebrates associated with macrophyte stands
Shallow water	Capture of organisms is dependent on flow through the sampler — therefore of limited use in slow-flowing and still waters
Deep water	Limited to the height of box
Soft substrate	Suitable for soft substrates
Hard substrate	Suitable for hard substrates — see boulders/bedrock
Boulders/bedrocks	Cannot be used
Collection of surface-dwelling macroinvertebrates	Not suitable for the collection of surface-dwelling taxa
Data type	Qualitative/semi-quantitative/quantitative

4.5 Cylinder sampler

4.5.1 Design

The sampler consists essentially of an open-ended cylinder, constructed of stainless steel, 0,5 mm thick with the lower edge serrated with teeth, each 10 mm deep (Figure 4). A plastic edging strip to protect the operator can cover the upper edge. Pushing the sampler into the substrate is facilitated by handles on the side of the device. To allow water to enter the sampler, an oval aperture should be cut in one side of the cylinder near the lower edge. To reduce the entry of drift organisms, this aperture is fitted with a stainless steel screen of coarse mesh of about 1 mm in diameter. Opposite this opening, a second hole is cut and is fitted with a short exit port to which a detachable collecting net is attached. Selection of the appropriate mesh size depends upon the nature of the investigation; indications of the sizes recommended are given in Table 3. The net should be 500 mm deep and made of nylon with a 50 mm deep canvas collar which holds a draw cord for attachment to the exit port. A shallow flange on the distal edge of the exit port ensures secure attachment. Two sizes of cylinder are generally used, with horizontal cross-sectional areas of 0,05 m² and of 0,1 m². The depth of both cylinders is usually about 450 mm (Figure 4).

In slow-flowing or still waters, a modified simple cylinder without flow-through and collection facilities can be used. Macroinvertebrates released by disturbance of the enclosed area can be collected by a scoop net or a sieve (with appropriate mesh size), or by suction pump.

4.5.2 Cylinder sampler operation

The sampling position should be approached from downstream to avoid undue disturbance of the sampling area. The sampler should be placed on the streambed so that the water inlet screen faces the current. The cylinder should be pushed, where possible, into the substrate to a maximum depth of 70 mm (using an alternating rotary motion). The collecting net should be arranged so that it is fully open and extends downstream of the cylinder. This permits an unimpeded flow of water through the net. The operator should stand immediately downstream of the sampler with feet astride the collecting net, using both feet and legs to maintain the position of the sampler.

Large stones should be examined within the sampler (any attached animals should be dislodged into the water flowing through the cylinder). Stirring the substrate by hand should disturb small stones and fine substrate. The stirring should be repeated to ensure the removal of all organisms. Care is needed in urban areas, where glass debris is often deposited in rivers. In these environments, disturbing the substrate may be safely achieved using a rod or hand rake. After allowing time for the dislodged material to be carried into the collecting net, the net should be removed. In doing so, the sample should be concentrated at the end of the net to facilitate removal. The net should be everted to transfer the catch to a tray for initial inspection and sorting, care being taken to ensure that all the animals in the net are removed (see net cleaning in 4.2.4.2). The sampler can be used in static water if the hands are used to generate enough current to draw organisms into the net. If the depth of water is greater than the sampler, results can only be considered to be semi-quantitative.

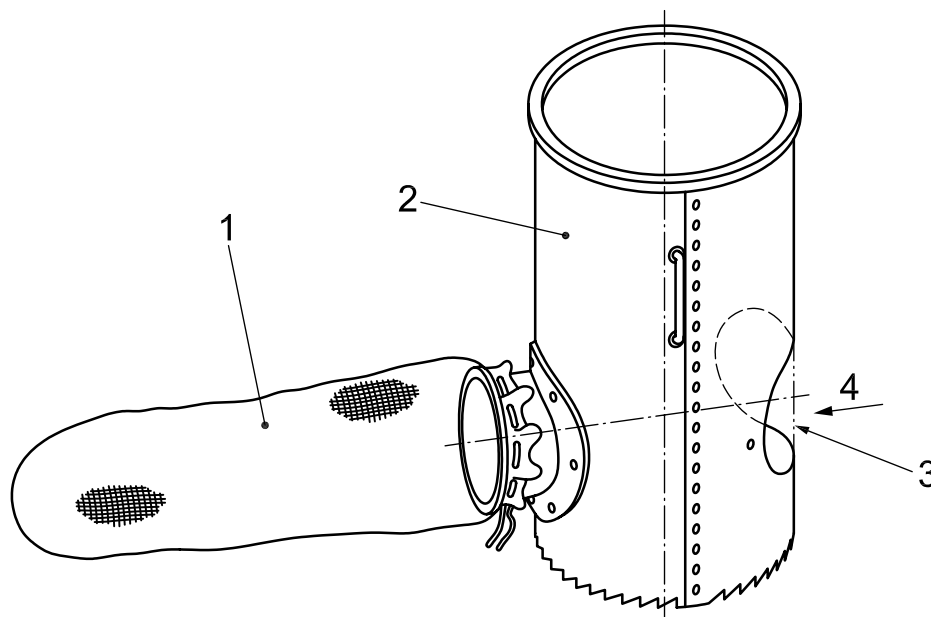

Key

- 1 collecting bag
- 2 metal cylinder
- 3 mesh screen
- 4 flow

Figure 4 — Cylinder sampler

4.5.3 Performance characteristics

Performance characteristics of the cylinder sampler are given in Table 7.

Table 7 — Performance characteristics of the cylinder sampler

Habitat sampled	Comment
Vegetation	Can be used over vegetation stands
Shallow water	Performance is dependent on flow — therefore of limited use in slow and still waters
Deep water	Limited to the height of cylinder
Soft substrate	Suitable for soft substrates
Hard substrate	Suitable for hard substrates — see boulders/bedrock
Boulders/bedrocks	Cannot be used
Collection of surface-dwelling macroinvertebrates	Not suitable for the collection of surface-dwelling taxa
Data type	Qualitative/semi-quantitative/quantitative

4.6 Naturalist's dredge

4.6.1 Design

The naturalist's dredge (Figure 5) has a sturdy rectangular frame (small version typically 46 cm × 19 cm of mass about 9 kg; large version typically 61 cm × 20 cm of mass about 15 kg) supporting a collecting net of about 35 cm in length. The mesh size of the net can be altered to suit the purpose of the study (see Table 3)

(Reference [12]). The catching net can be protected by a robust net having approximately two or three times the length of the mouth of the dredge.

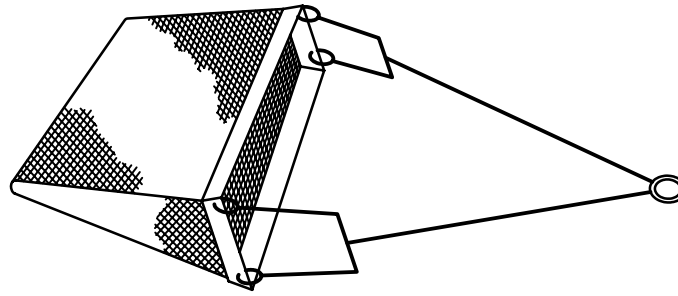

Figure 5 — Naturalist's dredge

4.6.2 Operation

The dredge should preferably be operated from a boat, but it can also be thrown from the bank of a river, canal or lake. When using a boat for dredging, the haul distance should first be determined and then the boat should be securely anchored upstream of the dredge position. The dredge should then be pulled up to the boat. This procedure is easier than towing the dredge directly, because of the resistance of the dredge on the bed of the river. Towing the dredge is not recommended because, when full of stones, the dredge can act as an anchor. The distance of the haul can be standardized by letting out a known length of rope. The haul distance is subject to the nature of the riverbed, e.g. on fine gravel the net can fill after 1 m. In substrates which consist of larger stones over which it tends to bounce, the dredge should be hauled over a distance of more than 5 m before a representative sample is obtained. To prevent the dredge lifting off the riverbed as it is hauled along, the angle of the rope to the riverbed should preferably be maintained below 25°. The sample should be emptied into a large container, taking care to transfer any animals retained in the net to the container. Excess water should then be decanted from the sample before the sample is preserved.

In combination with grab sampling, the dredge is mainly used to qualitatively capture rare, mobile, and fragile species. It can also be used to determine abundance if a device is added to the dredge to record the distance travelled.

4.6.3 Performance characteristics

Performance characteristics of the naturalist's dredge are given in Table 8.

Table 8 — Performance characteristics of the naturalist's dredge

Habitat sampled	Comment
Vegetation	Of limited use in dense vegetation stands
Shallow water	More suitable for deep waters
Deep water	Suitable
Soft substrate	Can be used for soft substrates, but only over short dredge distances to prevent serious clogging of the net
Hard substrate	Good for gravel and stone substrata (particle size >2 mm)
Boulders/bedrocks	Difficult to use on substrates of large stones
Collection of surface-dwelling macroinvertebrates	Not suitable for the collection of surface-dwelling organisms
Data type	Qualitative/semi-quantitative

4.7 Ekman-Birge grab

4.7.1 Grab design

The Ekman–Birge grab is an open-ended box (typically 15 cm × 15 cm × 15 cm, giving a sampling area of 225 cm²) (see Figure 6). It has two spring-loaded jaws that are activated by a manually operated release mechanism. There are two hinged plates at the top of the box, which reduce the shock wave as the sampler approaches the bed of the river (by allowing a free flow of water through the box) and also reduces the loss of material when the sampler is raised. A pole-operated version allows greater control and penetration than one suspended from a rope, but it can only be used in water of depth less than 3 m. The shape of the sample taken is approximately cubic from mud and approximately hemi-cylindrical from gravel.

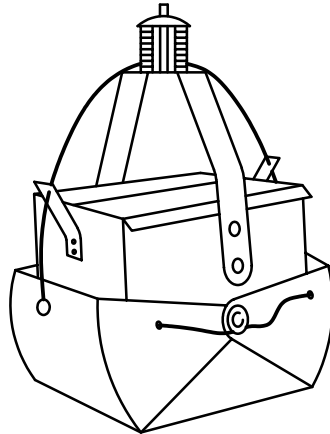

Figure 6 — Ekman–Birge grab

4.7.2 Operation

The pole-operated or rope-operated Ekman–Birge grab is suitable for obtaining qualitative and quantitative samples from mud and fine gravel (Reference [11]). The grab is set by drawing back the jaws and fixing them to the release mechanism. The sampler should then be lowered gently to the riverbed to prevent disturbance of the substrate, after which a pole-operated grab can be pushed firmly into place. To actuate the sampler, the release mechanism is triggered and the jaws close automatically. The sampler should then be immediately retrieved. The penetration depth of the Ekman–Birge grab should not be less than 10 cm. Samples collected with an Ekman–Birge grab shall be treated on board in the same way as samples taken by a Van Veen grab (see 4.9). The same reasons for discarding samples and the same recording protocol as for the Van Veen grab shall be followed.

4.7.3 Performance characteristics

Performance characteristics of the Ekman–Birge grab are given in Table 9.

Table 9 — Performance characteristics of the Ekman–Birge grab

Habitat sampled	Comment
Vegetation	Not suitable for vegetation sampling
Shallow water	Pole-mounted version suitable for shallow waters
Deep water	Rope-mounted version suitable for deep waters
Soft substrate	Suitable for soft substrates
Hard substrate	Suitable for hard substrates of particle size less than 16 mm
Boulders/bedrocks	Not suitable for sampling bedrocks or boulders
Collection of surface-dwelling macroinvertebrates	Not suitable for sampling surface-dwelling taxa
Data type	Qualitative/semi-quantitative/quantitative
Additional comments	A boat and winch are required because of the mass of the equipment. Can also be used from bridges or platforms

4.8 Ponar grab

4.8.1 Design

The weighted Ponar grab (typically of sampling area 560 cm² and mass about 23 kg) has two large jaws that close via a scissor action with a series of levers (see Figure 7). A crossbar holds the arms and jaws apart and is automatically released when the grab settles on the bed of the river or lake. As the grab is raised, the jaws close. The shape of the sample taken is hemi-cylindrical from mud and saucer-shaped from gravel; the sampler is therefore suitable for collecting organisms living on the surface of gravel substratum.

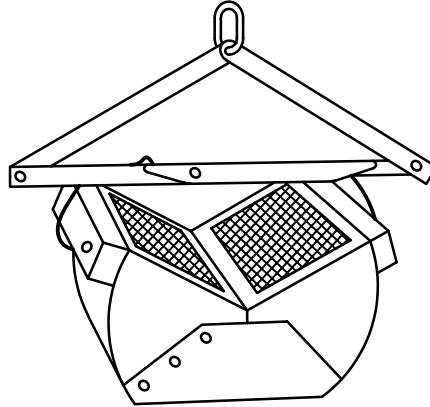

Figure 7 — Ponar grab

4.8.2 Grab operation

The weighted Ponar grab is suitable for qualitative and quantitative sampling on mud and fine gravel with small stones not greater than 16 mm long. The jaws should be opened and kept apart by a crossbar while the grab is suspended from its rope. The grab should then be lowered slowly to the riverbed and the tension released on the rope. This action allows the crossbar to fall and the jaws to close when the grab starts to be hauled up. As the digging action of the grab depends upon its own mass, it is essential that the grab be hauled up slowly using a winch while the jaws are closing. Care should be taken to collect any animals from inside the jaws when the grab is emptied. Samples should be discarded when the jaws are jammed open by stones or twigs, and a further sample should be taken. This sampler is normally used from a boat using a winch because of its mass, especially when it contains a sample.

4.8.3 Performance characteristics

Performance characteristics of the Ponar grab are given in Table 10.

Table 10 — Performance characteristics of the Ponar grab

Habitat type	Comment
Vegetation	Not suitable for vegetation sampling
Shallow water	Not suitable for shallow waters
Deep water	Suitable for deep waters
Soft substrate	Suitable for soft substrates
Hard substrate	Suitable for hard substrates of particle size less than 16 mm
Boulders/bedrocks	Of limited use
Collection of surface-dwelling macroinvertebrates	Not suitable for sampling surface-dwelling taxa
Data type	Qualitative/semi-quantitative/quantitative
Additional comments	A boat and winch are required because of the mass of the equipment. Can also be used from bridges or platforms

4.9 Van Veen grab

4.9.1 Design

The Van Veen grab is a lightweight sampler designed to take large samples in soft bottoms (see Figure 8). Its long lever arms and the sharp cutting edges on the bottom of the scoops, enable it to cut deeply into the softer bottoms. The weighted jaws, chain suspension, and doors and screens allow flow-through during lowering to the bottom and ensure vertical descent where strong underwater currents exist. The choice of the weights to be added to the grab depend on the characteristics of the sediments being sampled. The relatively large surface area and the strong closing mechanism allow the jaws to excavate relatively undisturbed sediments. The door screens have flexible rubber flaps which are lifted during lowering. When the grab settles on the bottom, the flaps fall back and cover the screens completely, preventing any loss of sediment during retrieval.

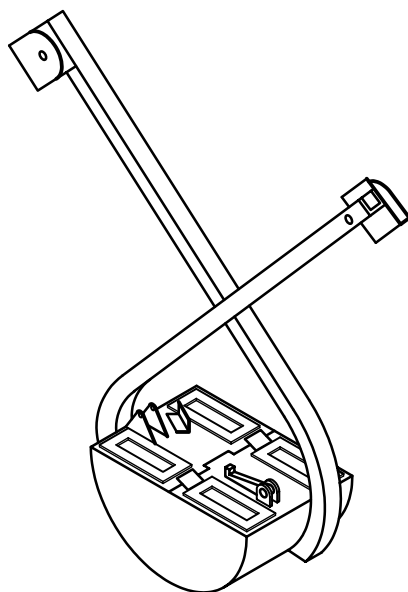

Figure 8 — The Van Veen grab (closed position)

4.9.2 Operation

The Van Veen grab is lowered in the open position and, when it comes to rest on the lake or riverbed, the release of tension on the bridle enables the triggering bar to drop and thus the two jaws can close. As the attached cable slowly becomes taut, the long arms extending from the jaws lift and the jaws dig deeper into the sediment trapping material as they close.

The sample of a Van Veen grab should include the upper sediment layer and at least 5 l of sandy or 10 l of alluvial mud sediments respectively.

Alternatively, the penetration depth can be measured and should be at least 5 cm for sandy sediments and 7 cm for alluvial mud sediments. For alluvial mud, the complete burying of the grabber should be avoided.

The sample shall be immediately checked after being taken on board to decide whether to pass it for further investigation or to discard it. Peculiar different samples compared to parallel samples shall be investigated separately.

Reasons to discard sample are:

- a) the penetrating depth was too low;
- b) the grabber is (almost) empty, and was obviously not completely closed;
- c) the grabber has penetrated the bottom at an angle and not vertically (very variable fill levels);
- d) losses of material during sieving or transfer of the organisms respectively.

If, at a sampling site, the minimal penetration depth was not achieved after five attempts, take the samples of the attempts with the highest penetration. Record the circumstances and reasons in the test report.

Fix the complete Van Veen grab sample after sieving. The complete sample is the remaining material after

- 1) complete sieving of the whole sample;
- 2) decanting of the whole sample (coarse sediments);
- 3) successive sieving of the whole sample over a 5 cm and 1 mm mesh size.

This means that the sample is treated differently according to the character of the sediments, but is not divided.

4.9.3 Performance characteristics

Performance characteristics of the Van Veen grab are given in Table 11.

Table 11 — Performance characteristics of the Van Veen grab

Habitat sampled	Comment
Vegetation	Not suitable
Shallow water	Not suitable for waters of less than 0,5 m
Deep water	Suitable
Soft substrate	Suitable
Hard substrate	Suitable for hard substrates of particle size <16 mm
Boulders/bedrocks	Not suitable
Collection of surface-dwelling macroinvertebrates	Not suitable
Data type	Qualitative/semi-quantitative/quantitative
Additional comments	A boat and winch are required because of the mass of the equipment. Can also be used from bridges or platforms

4.10 Polyp grab (orange peel grab)

4.10.1 General

Biological investigation of larger rivers and streams often encounters considerable practical difficulties. The particle size of the substratum and high flow velocities set limits on the conventional techniques for investigating the benthic zone of these waters (use of bottom grabs, suction samplers, and dredges for biological sampling). Even the possibility of a representative survey executed from the banks is impeded by extensive water level fluctuation. The polyp grab is a proven instrument for sampling macroinvertebrates in large and deep rivers with different substrates (Reference [13]) (see Figure 9).

4.10.2 Design

In most cases, the polyp grab operates with five or more gripper arms (e.g. grab dredger with 1 m³ capacity with 6 t load capacity) and is hydraulically driven. It can be placed into the river by a boom/crane. The polyp grab is well known from industrial applications where it is widely used, e.g. for the handling of scrap, garbage, rubble and waste paper. When using this grab for sampling macroinvertebrates, qualitative, semi-quantitative or quantitative samples can be taken with success from different depths (up to about 6 m) and from different substrate types (silt, sand, gravel, and even large stones and rocks).

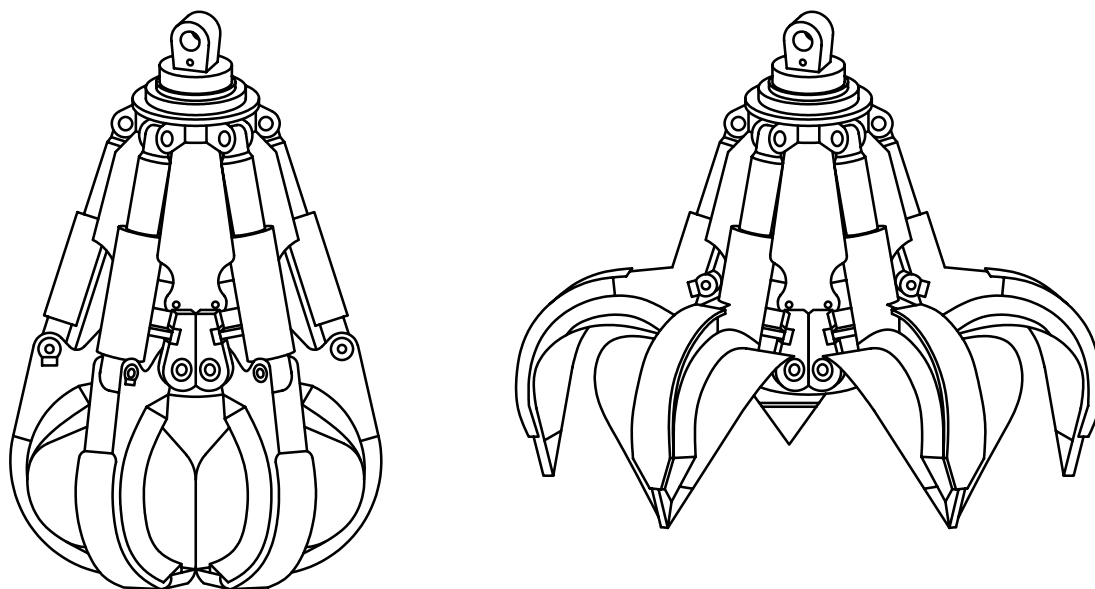

Figure 9 — Polyp grab

4.10.3 Operation

A polyp grab (orange peel grab) operated from a ship is appropriate for collecting macroinvertebrate samples from the sediments of larger rivers. When conducting faunal surveys, the substratum is removed directly from the surface (area about 1,5 m²) by closing the gripper arms and moving the sample on board the ship. The sample can be separated from larger substrates directly on the ship, and further treatment is conducted in the laboratory.

4.10.4 Performance characteristics

Performance characteristics of the Polyp grab are given in Table 12.

Table 12 — Performance characteristics of the polyp grab

Habitat sampled	Comment
Vegetation	Not suitable for vegetation sampling
Shallow water	Not suitable for shallow waters
Deep water	Suitable for deep waters
Soft substrate	Suitable for soft substrates
Hard substrate	Suitable for hard substrates
Boulders/bedrocks	Suitable for large stones/boulders
Collection of surface-dwelling macroinvertebrates	Not suitable for sampling surface-dwelling taxa
Data type	Qualitative/semi-quantitative/quantitative
Additional comments	A large boat is required because of the mass of the equipment

4.11 Air-lift sampler

4.11.1 Design

Air-lift samplers (typically of sampling area approximately 420 cm²) have a sampling pipe or riser of typically 10 cm diameter whose length can be altered by inserting lengths of pipe (References [9][10][19]). Air from compressed-air bottles is fed through hoses to the base of the riser (see Figure 9). An inclined pipe at the top of the riser directs the water and sample into a net while air is vented at its other end. The sampling area is enclosed by an open-ended stainless-steel cylinder which allows continuous replacement of water during pumping. The sampling cylinder and riser can be raised above the base of the outer cylinder in which they are supported, where they can be held by catches that are released by a handle near the top of the sampler. An air-driven vibrator is attached to the cylinder in some designs and air is supplied to the vibrator through pressure hosing. The passage of air through the cylinder helps to dislodge material within the cylinder, increases the uptake of material for a given air flow and can also increase the penetration of the cylinder into the substratum. Exhaust air from the vibrator can be returned to the surface to supplement the supply to the riser. An air-flow gauge is usually inserted in the final section of airline to the riser so that it measures the total flow to the riser. The gauge is essential for making efficient use of air and differing conditions of water depth and type of substratum.

4.11.2 Operation

Air-lift samplers can be used to obtain quantitative samples on substrata ranging from fine gravel to stones up to about 13 cm long, but they are not recommended for use on mud as the sample bag fills too rapidly and is prone to splitting. Although the samplers operate on a substratum that contains very large stones (>13 cm long), they neither lift such stones nor remove the animals firmly attached to them.

The sampler should be lowered to the substratum with the length of the riser adjusted so that its top is no higher than 30 cm above the water level. While it is being lowered, the riser should be held in the raised position by the catches. The cylinder should then be pushed into the riverbed until the stop flange is reached, by pressing down on the top of the sampler and rotating it back and forth by a few centimetres. The catches should then be released, allowing the riser to slide freely, although it does not drop because it is now level with the riverbed. A net should be placed over the outlet of the riser and the air turned on. The duration and amount of air used depends upon the depth of water and the type of substratum. It is essential that the sampler be kept vertical during operation. The sampler digs a vertically sided hole with a saucer-shaped base and only effectively samples animals to a depth of about 10 cm.

If it is impracticable to push the samplers into the substratum from a boat, these can be used quantitatively in the following less effective, but nevertheless adequate, mode, on stones of up to 2 cm long. An extension should be fitted to the lower end of the riser. The sampler should then be lowered to the bottom and the catches released (without pushing the sampler into the riverbed). The net should be positioned and the air turned on as before. The sample area is not restricted to the area of the bottom of the cylinder, since material is drawn in from outside the cylinder as the cylinder vibrates into the substrate. The sample profile will be conical. Note that the sampler becomes less efficient as the particle size of the substrate increases.

4.11.3 Performance characteristics

Performance characteristics of the air-lift sampler are given in Table 13.

Table 13 — Performance characteristics of the air-lift sampler

Habitat sampled	Comment
Vegetation	Not suitable for sampling vegetation
Shallow water	Of limited use in shallow waters as the rising air does not provide enough lift
Deep water	Suitable for deep waters
Soft substrate	Can be used on fine substrates
Hard substrate	Not suitable for hard substrates
Boulders/bedrocks	Can be used but not quantitatively
Collection of surface-dwelling macroinvertebrates	Not suitable for the collection of surface-dwelling taxa
Data type	Qualitative/semi-quantitative/quantitative

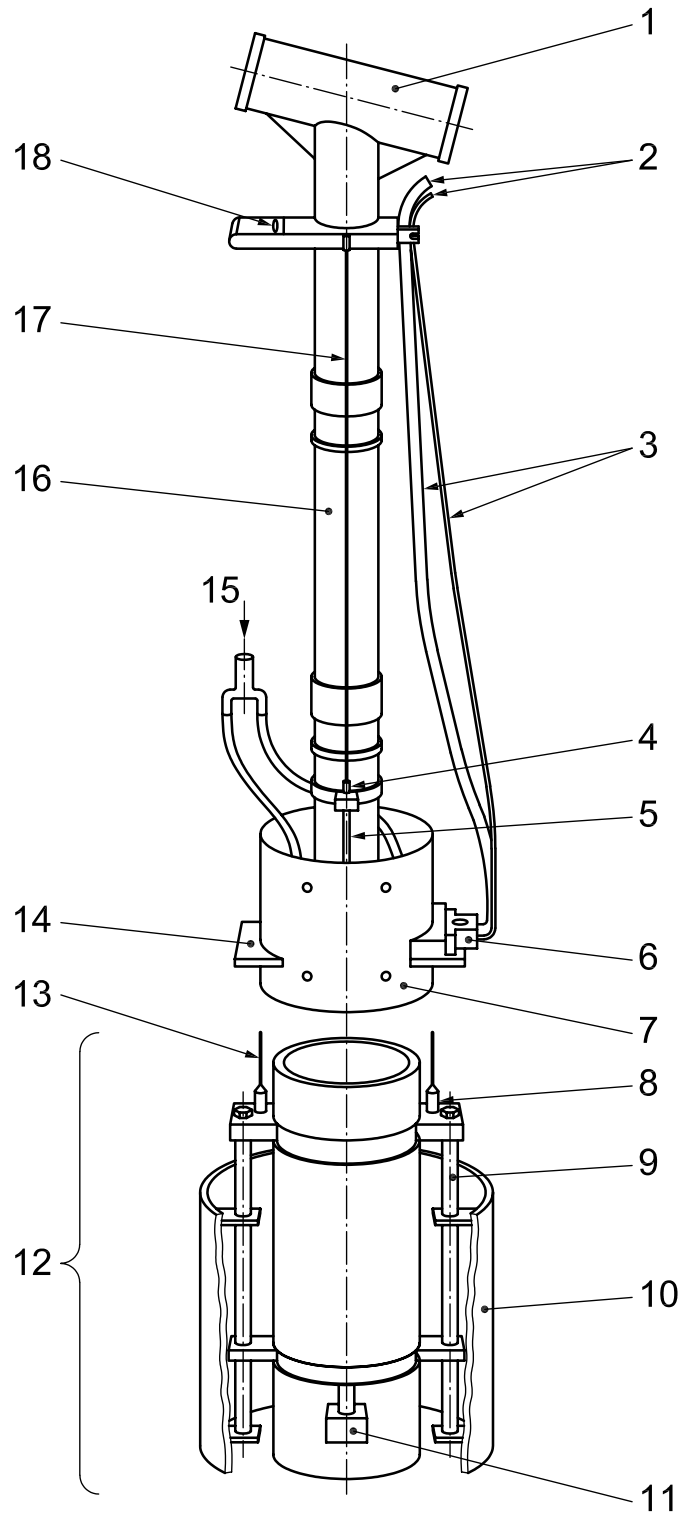

Key

- | | | | | | |
|---|----------------|----|---------------------|----|--|
| 1 | discharge pipe | 7 | collecting cylinder | 13 | steel cable |
| 2 | air | 8 | catches | 14 | block to prevent excessive penetration |
| 3 | air hose | 9 | slide rods | 15 | air supply |
| 4 | catches | 10 | collecting cylinder | 16 | riser |
| 5 | slide rods | 11 | air inlet | 17 | steel cable |
| 6 | vibrator | 12 | cut-away section | 18 | lever |

Figure 10 — Example of an air-lift sampler

4.12 Core and tube samplers

4.12.1 Core and tube sampler design

There are many designs of core and tube samplers (References [6][16]–[18]), which have an open-ended cylinder with a manual or automatic closer system (an example of one type is shown in Figure 11). The cylinder having a sharp lower end can also be removable or fixed. Different sizes of cylinder have been used; usually the diameter of the cylinder is between 80 mm and 140 mm and their height between 400 mm and 500 mm. The maximum mass (empty) of the sampler is approximately 10 kg. The sampling area is dependent on the size of the cylinder (50 cm to 154 cm²). If the sediment is very soft, it is possible to restrict its penetration with extra structures. These may also help to keep the sampler in the upright position when lowered. The size of the core and tube samplers depends mainly on the character of the sediments and the prevailing species to be sampled.

4.12.2 Core and tube sampler operation

The core or tube sampler can be used to obtain quantitative samples in soft substrates. The cylinder should penetrate at least 10 cm deep and the material should stay in it. The sampler can be used from a boat or on the top of ice in winter or from bridges or platforms. The sampler is set by fixing the release mechanism to the open position, whereupon it is lowered gently to the bottom. Water flows freely through the cylinder when lowered. When the sampler penetrates to the sediment, the closing system is either triggered automatically or the release mechanism is triggered manually to close the tube. The sampler is raised evenly and upright. When the sampler is out of water, a container should be placed under it to contain possible leakage. The upper level of the sample/material should be under 5 cm from the upper end of the sampler. The sampler is emptied through a sieve into a bowl or sample container. The depth of penetration of the sample should be recorded.

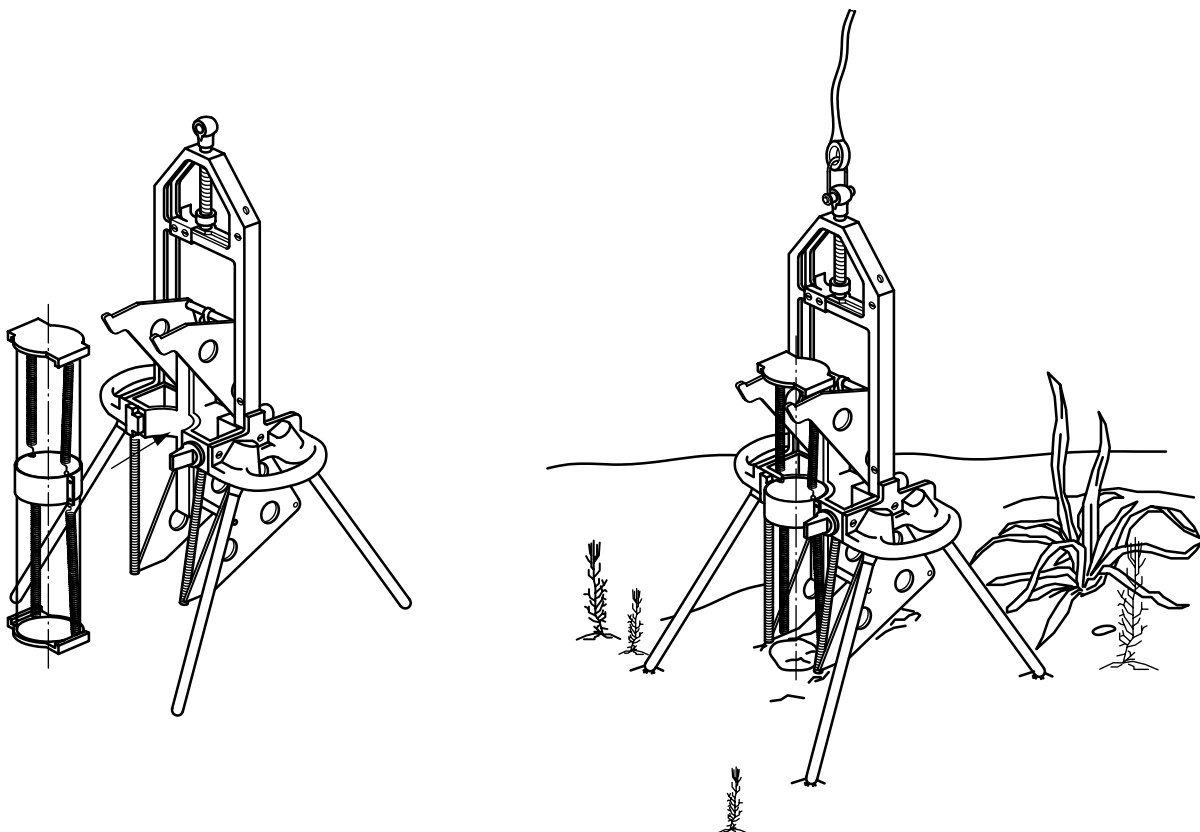

**Figure 11 — The Jenkin surface-mud sampler(Reference [18])
reproduced with the permission of the Freshwater Biological Association UK**

4.12.3 Performance characteristics

Performance characteristics of core and tube samplers are given in Table 14.

Table 14 — Performance characteristics of core and tube samplers

Habitat sampled	Comment
Vegetation	Not suitable
Shallow water	Suitable for shallow waters
Deep water	Suitable for deep waters
Soft substrate	Suitable
Hard substrate	Limited by the diameter of the tube
Boulders/bedrocks	Not suitable
Collection of surface-dwelling macroinvertebrates	Not suitable for the collection of surface-dwelling taxa
Data type	Qualitative/semi-quantitative/quantitative
Additional comments	Results are not acceptable if the sampler is leaking from the bottom or penetrates the sediment too deeply so that the material comes out of the upper end of the sampler

4.13 Colonization samplers

4.13.1 General

The colonization sampler is a passive sampling device (see Figure 12 for an example). It consists of a substrate which is left in the water for a specified time before it is removed and macroinvertebrates that have colonized it are removed. There are many different types of colonization sampler; the following have been used for routine ecological status assessment and pollution control purposes (Reference [6]).

4.13.2 Colonization bag

Each bag consists of approximately 40 pieces of a biological filter medium as used in sewage treatment, such as slag, placed inside a coarse mesh polyamide bag. Although the size and type of slag varies on a regional basis, including the surface area to volume ratio, it is recommended that slag of a nominal size of 40 mm × 5 mm be used, to reduce the overall mass of the sampler and prevent complete submersion and fouling in a mud substratum.

4.13.3 Colonization unit

Each unit consists of about 14 pieces of a plastic biological filter medium assembled in a cylindrical shape (see Figure 12). Inside, two layers of a single central piece surrounded by six peripheral ones are joined together. They can be joined using polyamide string or straps. To minimize the loss of animals while retrieving the sampler, the lower quarter, including the base, is covered with a polyamide gauze of 10 meshes per centimetre.

4.13.4 Colonization bag/unit operation

Colonization bags/units are positioned in fresh waters and left for a period of weeks. They can be retained with stones/bricks/stakes. During this time, they are colonized by macroinvertebrates. They are then removed from the river to allow qualitative, quantitative or semi-quantitative assessment of the colonization.

It should be ensured that the colonization sampler is placed in relation to the objectives of the study, for example in the main flow of the river for water quality investigations and not in a backwater or static area, unless the quality of these locations is specifically required. The sampler should be sufficiently covered by water and remote from the bank to minimize any likelihood of vandalism, becoming exposed during drought, or of the river level dropping thus causing fouling with extraneous matter.

When sampling in relatively shallow waters (1 m deep), a standard colonization unit should be pinned onto the bed of the river using a steel rod, with a bung fixed on the rod above the sampler to prevent any upward movement.

In deep waters (greater than 1 m deep) where it is impossible to peg a colonization bag/unit to the riverbed/lake bed, it is essential that the sampler be held against the bed of the river/lake. This is easily achieved by using a

weight, such as house bricks, which are tied to the sampler via a synthetic-fibre cord that is passed vertically through the centre of the sampler. If a synthetic-fibre cord is used, it should be attached securely to the bank, preferably in a concealed position above the high-water mark. In depositing zones, the weight at the base of the samples should penetrate into the surface mud until the colonization sampler rests on the surface substratum. If the penetration of the sampler is too much, a board of marine ply, for example, should be fixed to the base of the sampler before immersion.

To give a good assessment of the water quality, it is recommended that colonization samplers be left in place in the river being sampled for a period of at least four weeks. If such a period of immersion is impracticable, a feasibility study is recommended to determine the optimum colonization time at different sites.

After the period of immersion, the samplers should be removed from the water, care being taken to prevent any loss of organisms. This is facilitated by using a handnet and placing it immediately downstream of the sampler, and by moving the net under the sampler as the sampler is lifted from the bed of the river. In deeper waters, the mesh base of the standard colonization unit prevents any initial loss of organisms when lifting the sampler from the riverbed. In practice, it has been found useful to use a handnet to assist in lifting the sampler from the river. The complete sampler (excluding any weight), together with any animals in the handnet, should be placed in a strong plastics container in a small quantity of water and sealed for transport to the laboratory. If, for any reason, there is a delay in returning to the laboratory, preservation of the sampler and its contents should be carried out.

4.13.5 Performance characteristics

Performance characteristics of colonization samplers are given in Table 15.

Table 15 — Performance characteristics of colonization samplers

Habitat sampled	Comment
Vegetation	Suitable
Shallow water	Suitable
Deep water	Suitable
Soft substrate	Suitable
Hard substrate	Suitable
Boulders/bedrocks	Can be used
Collection of surface-dwelling macroinvertebrates	Not suitable
Data type	Semi-quantitative/qualitative

Dimensions in millimetres

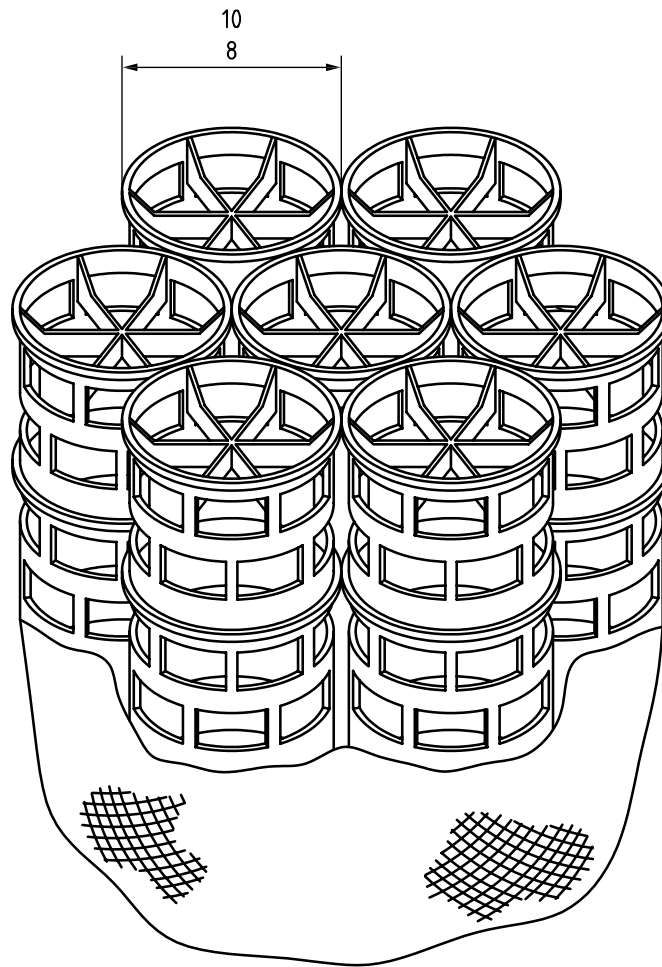

Figure 12 — A colonization unit

Bibliography

- [1] ISO 5667-1, *Water quality — Sampling — Part 1: Guidance on the design of sampling programmes and sampling techniques*
- [2] ISO 6107-2:2006, *Water quality — Vocabulary — Part 2*
- [3] ISO 8689-1, *Water quality — Biological classification of fresh waters — Part 1: Guidance on a procedure for settings boundaries between biological classes using data from surveys of aquatic fauna and flora*
- [4] ISO 8689-2, *Water quality — Biological classification of rivers — Part 2: Guidance on the presentation of biological quality data from surveys of benthic macroinvertebrates*
- [5] EN 16150, *Water quality — Guidance on pro-rata Multi-Habitat sampling of benthic macro-invertebrates from wadeable rivers*
- [6] HELLAWELL, J. *Biological surveillance of rivers*. Water Research Centre, 1978. 344 p.
- [7] KNOBEN, R.A.E., ROOS, C., VAN OIRSCHOT, M.C.M. *Working programme 1994/1995, Vol. 3: Biological assessment methods for watercourses*. Lelystad: RIZA for UN/ECE Task Force on Monitoring and Assessment, 1995. 86 p. Available (viewed 2012-06-26) at: http://www.unece.org/unecedevelco.iway.ch/fileadmin/DAM/env/water/publications/documents/biological_assessment_methods_watercourses.pdf
- [8] BLOMQUIST, S., ABRAHAMSSON, B. An improved Kajak type gravity core sampler for soft bottom sediments. *Schweiz. Z. Hydrol.* 1985, **47**, pp. 81–84
- [9] DRAKE, C.M., ELLIOT, J.M. A comparative study of three air-lift samplers used for sampling benthic macroinvertebrates in rivers. *Freshwater Biol.* 1982, **12**, pp. 511–533
- [10] DRAKE, C.M., ELLIOT, J.M. A new quantitative air-lift sampler for collecting macroinvertebrates on stony bottoms in deep rivers. *Freshwater Biol.* 1983, **13**, pp. 545–559
- [11] ELLIOT, J.M., DRAKE, C.M. A comparative study of seven grabs used for sampling benthic macroinvertebrates in rivers. *Freshwater Biol.* 1981, **11**, pp. 99–120
- [12] ELLIOT, J.M., DRAKE, C.M. A comparative study of four dredges used for sampling benthic macroinvertebrates in rivers. *Freshwater Biol.* 1981, **11**, pp. 245–261
- [13] ELLIOT, J.M., TULLET, P.A. *A bibliography of samplers for benthic macroinvertebrates*. Windermere: Freshwater Biological Association, 1978. 61 p. (Occasional Publication 4.)
- [14] ELLIOT, J.M., TULLET, P.A. *A supplement to a bibliography of samplers for benthic macroinvertebrates*. Windermere: Freshwater Biological Association, 1983. 27 p. (Occasional Publication 10.)
- [15] FURSE, M.T., WRIGHT, J.F., ARMITAGE, P.D., MOSS, D. An appraisal of pond-net samples for biological monitoring of lotic macro-invertebrates. *Water Res.* 1981, **15**, pp. 679–689
- [16] FRITHSEN, J.B., RUDNIC, D.T., ELMGREN, R. A new, flow-through corer for quantitative sampling of surface sediments. *Hydrobiologia* 1983, **99**, pp. 75–79
- [17] HAKALA, I. A new model of the Kajak bottom sampler and other improvements in zoobenthos sampling technique. *Ann. Zool. Fenn.* 1971, **8**, p. 422–426
- [18] OHNSTAD, F.R., JONES, J.G. *The Jenkins surface-mud sampler — User manual*. Windermere: Freshwater Biological Association, 1982. (Occasional Publication 15.)
- [19] PEHOFFER, H. E. A new quantitative air-lift sampler for collecting invertebrates designed for operation in deep, fast-flowing gravel bed rivers. *Arch. Hydrobiol.* 1998 [Suppl 115(2): *Large Rivers* **11**(2)], pp. 213–232

© 2010 International Organization for Standardization

ICS 13.060.70

Price based on 26 pages