

---

---

**Small craft — Quick release system for  
trapeze harness**

*Petits navires — Système de largage rapide pour harnais de trapèze*



Reference number  
ISO 10862:2009(E)

© ISO 2009

**PDF disclaimer**

This PDF file may contain embedded typefaces. In accordance with Adobe's licensing policy, this file may be printed or viewed but shall not be edited unless the typefaces which are embedded are licensed to and installed on the computer performing the editing. In downloading this file, parties accept therein the responsibility of not infringing Adobe's licensing policy. The ISO Central Secretariat accepts no liability in this area.

Adobe is a trademark of Adobe Systems Incorporated.

Details of the software products used to create this PDF file can be found in the General Info relative to the file; the PDF-creation parameters were optimized for printing. Every care has been taken to ensure that the file is suitable for use by ISO member bodies. In the unlikely event that a problem relating to it is found, please inform the Central Secretariat at the address given below.



**COPYRIGHT PROTECTED DOCUMENT**

© ISO 2009

All rights reserved. Unless otherwise specified, no part of this publication may be reproduced or utilized in any form or by any means, electronic or mechanical, including photocopying and microfilm, without permission in writing from either ISO at the address below or ISO's member body in the country of the requester.

ISO copyright office  
Case postale 56 • CH-1211 Geneva 20  
Tel. + 41 22 749 01 11  
Fax + 41 22 749 09 47  
E-mail [copyright@iso.org](mailto:copyright@iso.org)  
Web [www.iso.org](http://www.iso.org)

Published in Switzerland

# Contents

Page

Foreword.....	iv
Introduction .....	v
1 Scope .....	1
2 Normative references .....	1
3 Terms and definitions.....	1
4 Requirements .....	2
4.1 General.....	2
4.2 Identification.....	3
4.3 Inadvertent release or disconnection .....	3
4.4 Overload .....	3
4.5 Dynamic load.....	3
4.6 Operation in-line .....	4
4.7 No-load.....	4
4.8 Operation out of line.....	4
4.9 Re-arming .....	4
4.10 Resistance to debris.....	4
4.11 Resistance to salt water .....	4
4.12 Resistance to corrosion .....	4
5 Test methods.....	4
5.1 General.....	4
5.2 Sampling.....	5
5.3 Overload test .....	5
5.4 Operation in-line tests .....	7
5.5 Re-arming test.....	9
5.6 Operation out-of-line tests .....	9
5.7 Inadvertent release test.....	10
5.8 Debris test .....	11
5.9 Salt water test.....	11
5.10 Corrosion test .....	11
6 Marking .....	11
7 Information supplied by the manufacturer .....	11

## Foreword

ISO (the International Organization for Standardization) is a worldwide federation of national standards bodies (ISO member bodies). The work of preparing International Standards is normally carried out through ISO technical committees. Each member body interested in a subject for which a technical committee has been established has the right to be represented on that committee. International organizations, governmental and non-governmental, in liaison with ISO, also take part in the work. ISO collaborates closely with the International Electrotechnical Commission (IEC) on all matters of electrotechnical standardization.

International Standards are drafted in accordance with the rules given in the ISO/IEC Directives, Part 2.

The main task of technical committees is to prepare International Standards. Draft International Standards adopted by the technical committees are circulated to the member bodies for voting. Publication as an International Standard requires approval by at least 75 % of the member bodies casting a vote.

Attention is drawn to the possibility that some of the elements of this document may be the subject of patent rights. ISO shall not be held responsible for identifying any or all such patent rights.

ISO 10862 was prepared by Technical Committee ISO/TC 188, *Small craft*, in collaboration with Technical Committee CEN/TC 162, *Protective clothing including hand and arm protection and lifejackets*, in accordance with the Agreement on technical cooperation between ISO and CEN (Vienna Agreement).

## Introduction

Many people actively participate in small craft sailing with little evidence of accident, injury or death. Statistically, sailing is one of the safer leisure activities. There are, however, a very few documented accounts of injury and death owing to a participant being entrapped underwater as a result of not being able to detach themselves from the craft and, in some cases, not being able to release themselves from a sailing-craft trapeze.

This International Standard has been developed jointly by recreational-craft user groups and industry in an endeavour to reduce the possibility of entrapment underwater as a result of the inability of the user to release from a sailing-craft trapeze.

The scope of this International Standard is intentionally restricted and only covers the functioning of the safety release device of small sailing-craft trapeze systems. When developing this International Standard, ISO/TC 188/WG 14 emphasized that the safety of a craft and her entire management is the sole responsibility of the person in charge, who will also ensure that the craft and crew are adequate to face the conditions that might arise in the course of use. The establishment of this International Standard in no way limits or reduces the absolute responsibility of the person in charge and their responsibility for the crew, the craft and the management thereof.

.....

# Small craft — Quick release system for trapeze harness

## 1 Scope

This International Standard specifies requirements and test methods for quick release devices as a component of the small sailing-craft trapeze system worn whilst afloat. The quick release device is intended to quickly release the wearer from entrapment and minimize the risk of drowning in the event of a failure to release from the sailing-craft trapeze system by other means.

The quick release device is intended to be easily accessible and operated in all conditions that might occur whilst in use, including when a craft is capsized or inverted.

## 2 Normative references

The following referenced documents are indispensable for the application of this document. For dated references, only the edition cited applies. For undated references, the latest edition of the referenced document (including any amendments) applies.

ISO 9227, *Corrosion tests in artificial atmospheres — Salt spray tests*

EN 364:1992, *Personal protective equipment against falls from a height — Test methods*

EN 892:2004, *Mountaineering equipment — Dynamic mountaineering ropes — Safety requirements and test methods*

EN 13139:2002, *Aggregates for mortar*

## 3 Terms and definitions

For the purposes of this document, the following terms and definitions apply.

### 3.1

#### **sailing-craft trapeze system**

system of sailing-craft equipment and/or devices attached to a craft and user which can be used to support the main body mass of that user, thereby enabling an increase in the righting moment (through their body mass) on the craft

### 3.2

#### **user's attachment point**

point to which the trapeze system tensile load is applied and which connects and disconnects the user to and from the craft when the system is in normal use

### 3.3

#### **release attachment point**

point to which the trapeze system tensile load is applied and from which the user is released from the craft when the release system is activated

**NOTE** In any particular trapeze system, the release attachment point might be the same as, or may be additional to, the user's attachment point.

**3.4 quick release device**  
mechanism, device, etc. that brings about the intentional immediate release and separation of the release attachment point under critical emergency load conditions

**3.5 user main attachment fitting**  
**user attachment fitting**  
attachment, fitting or device possessing the user main attachment point and which, in normal use, remains with the user after disconnection

**3.6 craft main attachment fitting**  
**craft attachment fitting**  
attachment, fitting or device possessing the craft main attachment point and which, in normal use, remains with the craft after disconnection

**3.7 standard craft main attachment fitting**  
**standard craft attachment fitting**  
ring used as the craft main attachment fitting in cases of non-exclusively-compatible attachment fittings

**3.8 harness**  
textile assembly worn by the user, to which is attached that part of the user main attachment fitting that remains with the user after disconnection

**3.9 manufacturer's specified operational mass range**  
range specified by the manufacturer giving the user's minimum and maximum operational mass (the mass of the user ready to sail, equipped with trapeze harness, footwear, wetsuit, flotation device, etc.)

## 4 Requirements

### 4.1 General

The quick release device design shall have the aim of releasing the user from the craft main attachment fitting within 5 s.

The quick release device shall be simple to use and capable of operation with one gloved hand. Operation of the quick release device shall not present any significant risk to the user.

After all the tests described in Clause 5 have been carried out, the quick release device shall still be capable of correct operation and releasing the user from the main attachment fitting within 5 s.

User and craft main attachment fittings may or may not be exclusively-compatible with each other. Exclusively-compatible main attachment fittings shall only be used together and shall not be used with other designs. Non-exclusively-compatible main attachment fittings are not exclusive to each other, i.e. the user main attachment fitting (hereinafter referred to as "user attachment fitting") may be used with the craft main attachment fitting (hereinafter referred to as "craft attachment fitting") of a common design similar in shape and application to the standard craft attachment fitting (see Figure 1). The manufacturer of equipment fitted with a trapeze system shall provide either user and craft attachment fittings (see 3.5 and 3.6) that are exclusively-compatible or, if only supplying the part that will remain with the craft, shall provide a standard craft attachment fitting (see 3.7).



Dimensions in millimetres

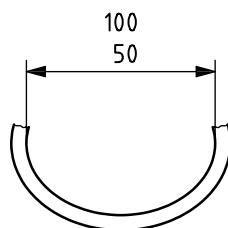

Figure 1 — Dimensions of standard craft attachment fitting

## 4.2 Identification

The quick release device shall be easily identifiable and shall be marked with text and/or a pictogram illustrating method of release, e.g. “Pull” and/or an arrow. The colour shall be in the orange-red colour range as defined in Table 1.

Table 1 — Chromaticity coordinates  $x$  and  $y$  and luminance factor  $\beta$  for orange-red non-fluorescent colours of quick release device

Colour	Chromaticity coordinates		Minimum luminance factor $\beta_{\min}$
	$x$	$y$	
Orange-red	0,610	0,390	0,15
	0,690	0,310	
	0,550	0,275	
	0,485	0,358	

## 4.3 Inadvertent release or disconnection

The quick release device shall be resistant to inadvertent release or disconnection under normal conditions of operation. It shall neither snag on other components of the sailing-craft trapeze system nor inadvertently release during the conduct of tests in accordance with 5.4, 5.6 and 5.7. When tested in accordance with 5.7, the quick release device is failed if it is inadvertently released from the user attachment fitting. If it is possible for the quick release device to partially open but not release and this is observed during the conduct of tests in accordance with 5.4, 5.6 and 5.7, this will also constitute a failure, as release could occur with geometry of different dimensions.

## 4.4 Overload

After testing in accordance with the static load test of 5.3.1 and 5.3.2, the quick release device shall release within 5 s. The quick release device shall neither break nor show signs of deformation that might compromise the correct functioning of the device.

## 4.5 Dynamic load

After testing in accordance with the dynamic load test of 5.3.3 and 5.3.4, the quick release device shall release within 5 s. The quick release device shall neither break nor show signs of deformation that might compromise the correct functioning of the device.

#### 4.6 Operation in-line

With a human test subject suspended in the configuration in accordance with 5.4.1, the quick release device shall release within 5 s when tested in accordance with 5.4.2 and 5.4.3.

#### 4.7 No-load

With a human test subject suspended in the configuration in accordance with 5.4.1 but no load applied, the quick release device shall release within 5 s when tested in accordance with 5.4.4.

#### 4.8 Operation out of line

With load applied to a torso dummy described in 5.6.1, the quick release device shall release within 5 s when tested in accordance with 5.6.2 and 5.6.3.

#### 4.9 Re-arming

After release, it shall be possible for the quick release device to be re-armed within 30 s when tested in accordance with 5.5. This may be achieved by the use of the original or replacement parts. If replacement parts are necessary, then this shall be specified in the information supplied by the manufacturer in accordance with Clause 7.

#### 4.10 Resistance to debris

After the assembled user attachment fitting, quick release device and harness has been subjected to the debris test in accordance with 5.8, it shall be possible to operate the quick release device within 5 s, and the quick release device shall release within 5 s when tested in accordance with 5.4.2.

#### 4.11 Resistance to salt water

After the assembled user attachment fitting, quick release device and harness has been subjected to saltwater in accordance with 5.9, it shall be possible to operate the quick release device within 5 s, and the quick release device shall release within 5 s when tested in accordance with 5.4.2.

#### 4.12 Resistance to corrosion

When assembled user attachment fitting, quick release device and harness has been tested in accordance with 5.10, metal components shall not be significantly affected by corrosion. It shall be possible to operate the quick release device within 5 s, and the quick release device shall release within 5 s when tested in accordance with 5.4.2.

### 5 Test methods

#### 5.1 General

The tests shall be carried out in sequence on each sample. The operation in-line 100° test (5.4.2) shall be repeated on completion of each of the debris (5.8), salt water (5.9) and corrosion (5.10) tests. The test results shall be recorded.

The human subject performance tests shall be witnessed by a test panel composed of a minimum of two experts familiar with testing and with the products specified.

A minimum of two test subjects shall be used for the human performance tests (5.4 and 5.5). One test subject shall have a body mass within  $\begin{matrix} +2 \\ -5 \end{matrix}$  kg of the minimum mass in the manufacturer's specified mass range. One test subject shall have a body mass within  $\begin{matrix} +5 \\ -2 \end{matrix}$  kg of the maximum mass in the manufacturer's specified mass range.

At least one male and one female subject shall be used, of average strength and dexterity and familiarized with the use of the device but shall not be experienced users.

## 5.2 Sampling

All tests shall be conducted on three samples of the quick release device provided by the manufacturer.

## 5.3 Overload test

### 5.3.1 Configuration for static test

The harness, the user attachment fitting and the quick release device shall be assembled according to the information supplied by the manufacturer.

If the user attachment fitting to be tested is of the exclusively-compatible type, the exclusively-compatible craft attachment fitting shall be used for the tests. Otherwise, the standard craft attachment fitting shall be used.

For the static test, a torso dummy conforming to EN 364:1992, 4.2 shall be used. Suspend a dynamic mountaineering rope in accordance with EN 892:2004, 3.2, with a nominal diameter of 11 mm, from a fixed anchorage point (conforming to EN 364:1992, 4.4.1). The height of the test system and torso dummy above the floor shall be such that when the system is released, the dummy falls a minimal distance onto a force-absorbing surface.

### 5.3.2 Static test procedure

Attach the craft attachment fitting to the dynamic mountaineering rope and suspend from the fixed anchorage point.

Fit the harness, quick release device and user attachment fitting on the torso dummy according to the information supplied by the manufacturer and attach to the craft attachment fitting. Apply additional load to the torso dummy such that the total load (dummy mass + additional mass) is twice the maximum mass specified in the manufacturer's specified operational mass range.

After 5 min, undertake a visual inspection to determine whether any breakage or deformation has occurred that might compromise the correct functioning of the quick release device.

### 5.3.3 Configuration for dynamic test

The user attachment fitting and quick release device shall be assembled according to the information supplied by the manufacturer.

If the user attachment fitting to be used in the test is of the exclusively-compatible type, the exclusively-compatible craft attachment fitting shall be used for the tests. Otherwise, the standard craft attachment fitting shall be used.

The test apparatus for the dynamic test shall conform to EN 364:1992, 4.2 (torso dummy), 4.4 (structure) and 4.6 (test facility release device), configured in a manner similar to Figure 2. Dynamic mountaineering rope in accordance with EN 892:2004, 3.2, shall be used to suspend the torso dummy from the fixed anchorage point. The test facility quick release device shall be suspended from a second anchorage point in accordance with Figure 2 at a maximum distance of 300 mm from the test apparatus anchorage point.

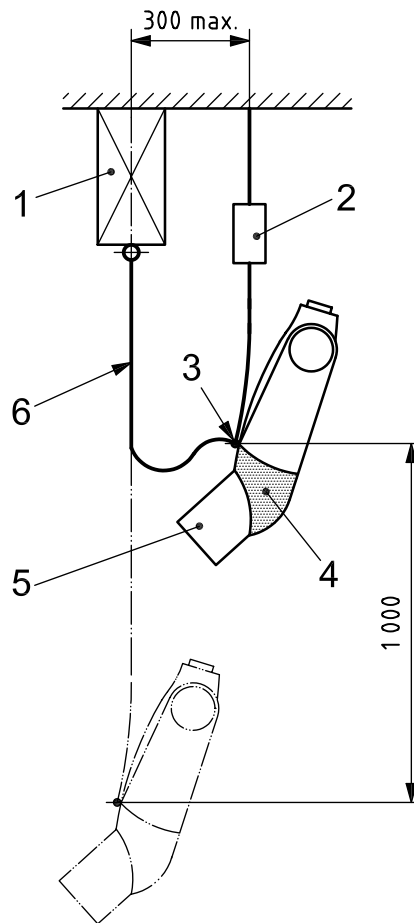

**Key**

- 1 test apparatus
- 2 test facility release device
- 3 attachment point
- 4 trapeze harness
- 5 torso dummy
- 6 dynamic mountaineering rope

**Figure 2 — Configuration of the dynamic test**

**5.3.4 Dynamic test procedure**

Attach the craft attachment fitting to the dynamic mountaineering rope and suspend from the fixed anchorage point.

Fit the harness, quick release device and user attachment fitting, in accordance with the information supplied by the manufacturer, on the torso dummy and attach to the craft attachment fitting. The lowest point of the system under test and the torso dummy, when suspended from this anchorage point, shall be at a height of  $(200 \pm 50)$  mm above the floor, over a force-absorbing surface.

The torso dummy [with a mass of  $(100 \pm 1)$  kg] shall then be raised 500 mm by the craft attachment fitting, and this attachment fitting shall be secured to a test facility release device. Operate the test facility release device so as to drop the torso dummy and harness system incorporating the quick release device under test.

Record whether any breakage or deformation has occurred that might compromise the correct functioning of the quick release device. If still intact, attempt to activate the quick release device.

## 5.4 Operation in-line tests

### 5.4.1 Test configuration

The operation in-line tests shall be conducted in the configuration corresponding to the situations in which the elements of the trapeze system, the user attachment fitting, quick release device, craft attachment fitting and harness will be used.

The user attachment fitting, quick release device and harness, if integral with the user attachment fitting and/or quick release device, shall be assembled according to the information supplied by the manufacturer. If the harness is not an integral part of the user attachment fitting and/or quick release device, a test harness recommended by the manufacturer shall be used.

If the user attachment fitting to be tested is of the exclusively-compatible type, the exclusively-compatible attachment fittings shall be used in the tests. Otherwise, the standard craft attachment fitting shall be used.

Dynamic mountaineering rope in accordance with EN 892:2004, 3.2, shall be provided for this test. Suspend the craft attachment fitting from the mountaineering rope in the position given in Figure 3.

Dimensions in millimetres

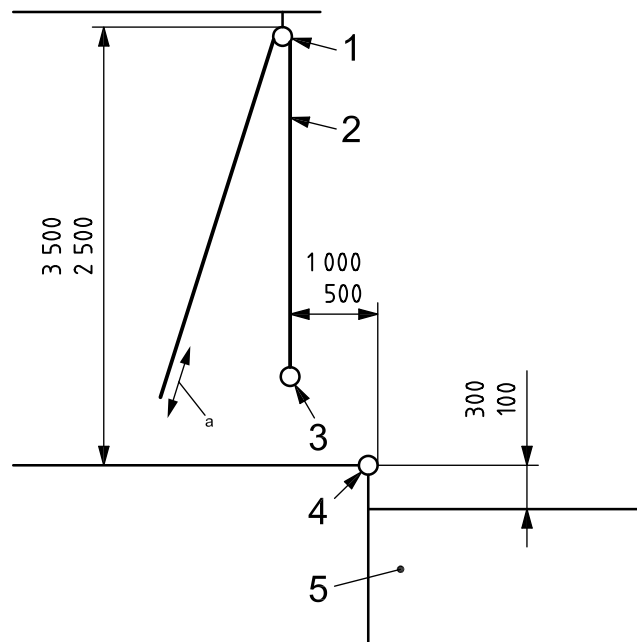

#### Key

- 1 fixed pulley
- 2 mountaineering rope
- 3 craft attachment fitting
- 4 foot support
- 5 water of suitable depth or other soft landing

a Vertical adjustment.

**Figure 3 — Test configuration for operation in-line tests**

### 5.4.2 Operation in-line 100° test procedure

Fit the harness on the test subject and assemble the user attachment fitting and quick release device to be tested. Ensure that the harness is tight to the user's torso. Additionally, dress the test subject in full-finger neoprene gloves of 2 mm thickness, full blackout blindfold and face protection from moving parts.

Apply additional mass to the harness so that the total mass, including the mass of the test subject and harness itself, is at least equal to the maximum mass specified in the manufacturer's specified operational mass range.

Suspend the assembled user attachment fitting, quick release device, harness and test subject from the craft attachment fitting so that the main and release attachment points connect. The test subject's feet shall be in contact with the foot support, with their body straight and suspended over the water.

The test subject shall be in line with and facing the suspension cord.

The angle between the upper part of the test subject's body and the suspension cord shall be 100° (see Figure 4). The test subject's hands shall be placed on top of their head.

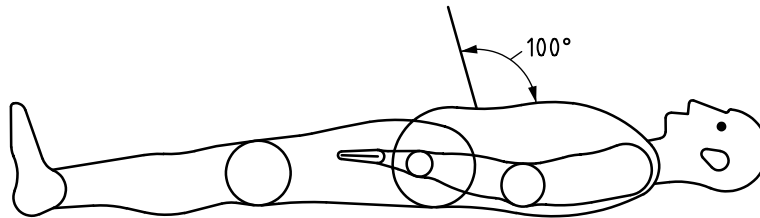

Figure 4 — Operation in-line 100° test

The test panel shall visually check that:

- the quick release device is easily accessible;
- the operations are compatible with upper limb mobility;
- the device does not present risks of accidental release;
- the operation of the device is not otherwise compromised;
- the device does not present any harm to the user.

At an unprompted or unanticipated sound signal, the test user shall attempt to activate the quick release device using each hand in turn.

### 5.4.3 Operation in-line 45° test procedure

Repeat the test according to 5.4.2, but the angle between the upper part of the test subject's body and the suspension cord shall be 45° (see Figure 5).

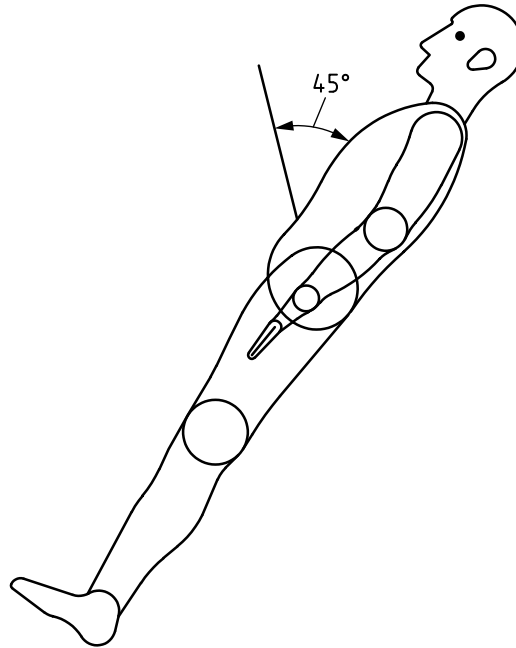

Figure 5 — Operation in-line 45° test

#### 5.4.4 No-load test

Repeat the test according to 5.4.2 with the test subject standing below the suspension cord pulley with no tension applied to the device.

#### 5.5 Re-arming test

Immediately after the no-load test according to 5.4.4, without removing the harness, the user shall re-assemble the quick release device with the original or replacement parts within 30 s.

#### 5.6 Operation out-of-line tests

##### 5.6.1 Test configuration

This test shall be conducted using a torso dummy with a mass of  $(100 \pm 1)$  kg in accordance with EN 364:1992, 4.2. The operation out-of-line tests shall be conducted in the configuration corresponding to the situations in which the elements of the trapeze system, the user attachment fitting, quick release device, craft attachment fitting and harness will be used.

The user attachment fitting, quick release device and harness, if integral with the user attachment fitting and/or quick release device, shall be assembled according to the information supplied by the manufacturer. If the harness is not an integral part of the user attachment fitting and/or quick release device, a test harness recommended by the manufacturer shall be used.

If the user attachment fitting to be used in the test is of the exclusively-compatible type, the exclusively-compatible attachment fittings shall be used. Otherwise, the standard craft attachment fitting shall be used.

Fit the harness, the assembled user attachment fitting and quick release device to be tested onto the torso dummy. The member of the test panel tasked with operating the quick release device (the operator) shall don full-finger neoprene gloves of 2 mm thickness and face protection from moving parts.

Lay the torso dummy at the edge of a flat surface with sufficient distance above the floor to suspend a load as illustrated in Figure 6. Additional fixings may be used to retain the torso dummy in position during the test provided that they do not impinge upon the quick release device. The load shall be suspended from a dynamic mountaineering rope in accordance with EN 892:2004, 3.2.

### 5.6.2 Operation out-of-line to the right test procedure

Attach the craft attachment fitting to the quick release device, user attachment fitting and harness in accordance with 5.6.1. Suspend a dynamic mountaineering rope from the craft attachment fitting to the right of the torso dummy (see Figure 6). Add mass to the lower end of the dynamic mountaineering rope progressively until this reaches 50 % of the maximum mass specified in the manufacturer's specified operational mass range.

The test panel shall visually check that:

- the release device is easily accessible;
- the operations are compatible with upper limb mobility;
- the device does not present any harm to the user.

At a time indicated by a member of the test panel, the operator shall attempt to activate the quick release device.

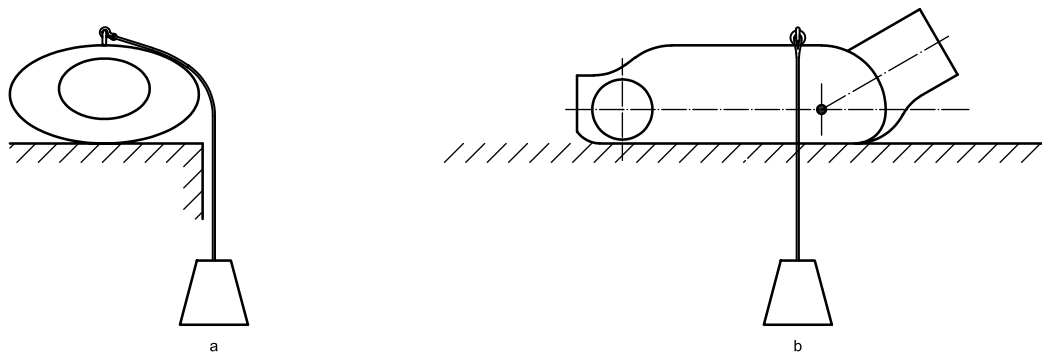

- a View from head.
- b View from side.

Figure 6 — Operation out-of-line to the right test

### 5.6.3 Operation out-of-line to the left test procedure

Repeat the test according to 5.6.2 but with the mountaineering rope and mass suspended to the left of the torso dummy.

## 5.7 Inadvertent release test

Attach the craft attachment fitting to the user attachment fitting, quick release device and harness. Move the craft attachment fitting by hand as far as possible in all directions without releasing the user attachment fitting from the craft attachment fitting. Detach the user attachment fitting from the craft attachment fitting. Re-attach and repeat this procedure 5 times. Assess the tendency of the quick release to accidentally release from the user attachment fitting throughout the test. Assess any snagging of the quick release device on other components of the trapeze system.



## 5.8 Debris test

Bury the assembled user attachment fitting, quick release device and harness to a depth of between 50 mm and 250 mm and compact, by hand, in a mixture of 50 % saltwater, 25 % fine sand (in accordance with EN 13139:2002) and 25 % mud and silt by volume for between 60 s and 100 s. Remove the complete assembly from the mixture and clean by pouring, under gravity, no more than 0,25 l of fresh water over the quick release device with no abrasion or rubbing. After cleaning, test as specified in 5.4.2.

## 5.9 Salt water test

Immerse the assembled user attachment fitting, quick release device and harness in a bath of saltwater for 10 days. Remove the complete assembly and after cleaning, i.e. pouring, under gravity, of no more than 0,25 l of fresh water over the quick release device with no abrasion or rubbing, test as specified in 5.4.2.

## 5.10 Corrosion test

Expose the assembled user attachment fitting, quick release device and harness to the salt spray test in accordance with ISO 9227 for a period of 96 h. Remove the complete assembly without any cleaning and leave the complete assembled trapeze system in a moist environment, untouched, for not less than 90 days. After cleaning, i.e. pouring, under gravity, of no more than 0,25 l of fresh water over the quick release device with no abrasion or rubbing, test as specified in 5.4.2.

## 6 Marking

The quick release device and/or harness, if sold with the quick release device, shall be both permanently and legibly marked with the following, which shall be given, as a minimum, in the official language of the country of destination.

- a) Identification of the manufacturer — at least the name of the manufacturer or representative and their mailing address.
- b) The manufacturer's serial number or batch number and quarter (or month) and year of manufacture. Months are to be given as Arabic numerals (1-12) and quarters as Roman numerals (I – IV);
- c) The number of this International Standard, i.e. ISO 10862.
- d) The manufacturer's specified operational mass range.
- e) Text and/or a pictogram illustrating method of release, e.g. "pull" and/or an arrow.
- f) In the case of attachment fittings of an exclusively-compatible type, an indication that they should only be used in conjunction with named compatible craft attachment fittings.

Where the product is too small to allow all of the marking to be affixed, at least items c), d) and e) above and the manufacturer's name or symbol shall be provided and the relevant information given on the packaging and in the information supplied by the manufacturer (see Clause 7).

## 7 Information supplied by the manufacturer

The quick release device and/or harness, if sold with the quick release device, shall be supplied with an explanatory leaflet or manual, written, as a minimum, in the official language(s) of the country of destination, containing at least the following items and including:

- a) items given in Clause 6, a) to f);
- b) the recommendation that the user should try out the quick release device to ascertain its performance before use;

- c) full instructions for the quick release device assembly and installation procedure, sufficiently detailed and precise to avoid errors in assembly and installation;
- d) full donning instructions and instructions for use;
- e) definition of the difference between exclusively-compatible attachment fittings and non-exclusively-compatible attachment fittings, specifying which is applicable;
- f) compatibility of the quick release device with other items such as the trapeze harness and clothing;
- g) any limitations of use;
- h) statement whether replacement parts are necessary, giving details of such where appropriate;
- i) statement of maintenance and materials replacement periods of the quick release device under normal conditions of use and maintenance;
- j) storage, cleaning, maintenance and servicing procedures as applicable;
- k) detailed and precise re-arming and servicing instructions. These procedures shall not allow “reasonably foreseeable” errors that could compromise function in accordance with this International Standard.

© ISO 2009 – All rights reserved



---

---

**ICS 47.080**

Price based on 12 pages