**Industrial sewing machines — Safety
requirements for sewing machines, units
and systems**

*Machines à coudre industrielles — Exigences de sécurité pour
machines à coudre, unités et systèmes de couture*



Reference number
ISO 10821:2005(E)

© ISO 2005

PDF disclaimer

This PDF file may contain embedded typefaces. In accordance with Adobe's licensing policy, this file may be printed or viewed but shall not be edited unless the typefaces which are embedded are licensed to and installed on the computer performing the editing. In downloading this file, parties accept therein the responsibility of not infringing Adobe's licensing policy. The ISO Central Secretariat accepts no liability in this area.

Adobe is a trademark of Adobe Systems Incorporated.

Details of the software products used to create this PDF file can be found in the General Info relative to the file; the PDF-creation parameters were optimized for printing. Every care has been taken to ensure that the file is suitable for use by ISO member bodies. In the unlikely event that a problem relating to it is found, please inform the Central Secretariat at the address given below.

© ISO 2005

All rights reserved. Unless otherwise specified, no part of this publication may be reproduced or utilized in any form or by any means, electronic or mechanical, including photocopying and microfilm, without permission in writing from either ISO at the address below or ISO's member body in the country of the requester.

ISO copyright office
Case postale 56 • CH-1211 Geneva 20
Tel. + 41 22 749 01 11
Fax + 41 22 749 09 47
E-mail copyright@iso.org
Web www.iso.org

Published in Switzerland

Contents

Page

Foreword.....	v
Introduction	vi
1 Scope	1
2 Normative references	1
3 Terms and definitions	3
4 Significant hazards	5
4.1 General.....	5
4.2 Mechanics.....	5
4.3 Electricity/Control.....	6
4.4 Thermal hazards	6
4.5 Noise	6
4.6 Radiation.....	6
4.7 Ergonomics	7
4.8 Special hazards.....	7
4.9 Danger zones	8
5 Safety measures and requirements	15
5.1 General principles.....	15
5.2 Requirements for all types of industrial sewing machines	15
5.2.1 Mechanical equipment	15
5.2.2 Electrical equipment/control/control gear	18
5.2.3 Thermal requirements	20
5.2.4 Noise	20
5.2.5 Radiation.....	21
5.2.6 Ergonomics	22
5.3 Specific requirements for particular types of industrial sewing machines.....	22
5.3.1 Button, buttonhole and programmable pattern sewing machines, bartacking machines.....	22
5.3.2 Quilting machines.....	23
5.3.3 Bag closing sewing machines in the packaging industry.....	23
5.3.4 Embroidery machines	23
5.3.5 Glove sewing machines	24
5.3.6 Sewing machines for shoe repair	24
5.3.7 Blindstitch sewing machines	24
5.3.8 Linking machines.....	24
6 Verification of safety requirements or measures	24
7 Information on use and maintenance	26
7.1 General.....	26
7.2 Marking	26
7.3 Warning of residual risk	27
7.4 Instructions	27
7.4.1 General information.....	27
7.4.2 Particular information	28
Annex A (normative) Finger deflecting device.....	29
Annex B (normative) Warning of residual risk.....	32
Annex C (normative) Noise test code	35
Annex D (normative) Needle breakage protection shield	50
Annex E (normative) Belt guard at sewing machine drive (motor).....	51

Annex F (informative) Safe fastening of belt pulley at drive shaft of clutch or positioning drives	53
Annex G (informative) Safe mounting of adaptable positioner/synchronizer at sewing machine shaft	60
Annex H (informative) Safe mounting of sewing machine drives	61
Annex I (informative) Noise declaration examples.....	66
Annex J (informative) Examples of noise reduction measures at the design stage	69
Annex K (normative) Written warning — Languages	70
Annex L (informative) Ergonomic principles	74
Bibliography	75

Foreword

ISO (the International Organization for Standardization) is a worldwide federation of national standards bodies (ISO member bodies). The work of preparing International Standards is normally carried out through ISO technical committees. Each member body interested in a subject for which a technical committee has been established has the right to be represented on that committee. International organizations, governmental and non-governmental, in liaison with ISO, also take part in the work. ISO collaborates closely with the International Electrotechnical Commission (IEC) on all matters of electrotechnical standardization.

International Standards are drafted in accordance with the rules given in the ISO/IEC Directives, Part 2.

The main task of technical committees is to prepare International Standards. Draft International Standards adopted by the technical committees are circulated to the member bodies for voting. Publication as an International Standard requires approval by at least 75 % of the member bodies casting a vote.

Attention is drawn to the possibility that some of the elements of this document may be the subject of patent rights. ISO shall not be held responsible for identifying any or all such patent rights.

ISO 10821 was prepared by Technical Committee ISO/TC 148, *Sewing machines*.

Introduction

This International Standard is intended to provide manufacturers, users and official bodies with safety requirements which, in view of the state of the art, are to be met for industrial sewing machines, units and systems.

For machinery and hazards not within the scope of this International Standard, see ISO 12100-1 and ISO 12100-2.

The concept of this International Standard is to deal first in general and then in detail with significant hazards (see Clause 4), as well as safety requirements (see Clause 5); it starts with those requirements applicable to all types of industrial sewing machines in order to arrive at specific requirements for particular types of machines.

A peculiarity of industrial sewing machines is that sewing units and systems are frequently built up by the user from components emanating from various manufacturers. Furthermore, in the course of their period of use, units and systems may be adapted by the user for different tasks (owing to, for example, frequent changes in fashion) by means of the interchange of components or the addition of supplementary equipment. Such measures can also serve the purpose of increasing the degree of automation. As a result, the user who assembles several components into a new sewing unit or system is in the position of a manufacturer and thus, like the manufacturer, is responsible for assuring that any hazards inherent in the operation of the new combination are eliminated, and that it conforms to this International Standard and any other relevant standard or regulation.

Industrial sewing machines — Safety requirements for sewing machines, units and systems

1 Scope

This International Standard identifies hazards and specifies safety requirements applicable to sewing machines, sewing units and sewing systems designed for professional (industrial, commercial or laboratory) use in industries including the clothing and footwear, leather goods, shirts and blousery, hosiery and knitwear, lingerie, glove, upholstery and packaging industries, and in shoe repair.

The information on use and maintenance of such machines in other industries could give rise to hazards not considered in this International Standard.

The requirements of this International Standard are applicable to machinery installed in dry and well-kept, clean locations and processing dry sewing material. Where the sewing machines, sewing units or sewing systems are used in other than dry and well-kept, clean locations, more stringent measures could be necessary: for example, the higher degree of protection provided by enclosures (IP code — see IEC 60529)^[5].

The purpose of this International Standard is to assist the manufacturer to design machinery such that the risks arising from its defined, intended use and maintenance are reduced or eliminated. The significant hazards and hazardous situations are given together with a reference to the corresponding safety requirement or measure in 4.2 to 4.8. Significant hazards are those identified and estimated as requiring action to reduce the risk they pose.

This International Standard is not applicable to stepping frame sewing machines, shoe bottom stitching machines, large shuttle embroidery machines in accordance with ISO 11111 ^[1], integrated sewing systems within in the scope of ISO 11161 ^[2] or household sewing machines in accordance with IEC 60335-2-28 ^[4].

NOTE If household sewing machines are used for professional purposes, it could be necessary to take measures in accordance with this International Standard (e.g. the use of a finger deflecting device).

2 Normative references

The following referenced documents are indispensable for the application of this document. For dated references, only the edition cited applies. For undated references, the latest edition of the referenced document (including any amendments) applies.

ISO 286 (all parts), *ISO system of limits and fits*

ISO 639 (all parts), *Codes for the representation of names of languages*

ISO 2768 (all parts), *General tolerances*

ISO 3740:2000, *Acoustics — Determination of sound power levels of noise sources — Guidelines for the use of basic standards*

ISO 3741:1999, *Acoustics — Determination of sound power levels of noise sources using sound pressure — Precision methods for reverberation rooms*

ISO 10821:2005(E)

ISO 3743-1:1994, *Acoustics — Determination of sound power levels of noise sources — Engineering methods for small, movable sources in reverberant fields — Part 1: Comparison method for hard-walled test rooms*

ISO 3744:1994, *Acoustics — Determination of sound power levels of noise sources using sound pressure — Engineering method in an essentially free field over a reflecting plane*

ISO 3745:2003, *Acoustics — Determination of sound power levels of noise sources using sound pressure — Precision methods for anechoic and semi-anechoic rooms*

ISO 3746:1985, *Acoustics — Determination of sound power levels of noise sources using sound pressure — Survey method using an enveloping measurement surface over a reflecting plane*

ISO 3747:2000, *Acoustics — Determination of sound power levels of noise sources using sound pressure — Comparison method in situ*

ISO 3864-2:2004, *Graphical symbols — Safety colours and safety signs — Part 2: Design principles for product safety labels*

ISO 4183:1995, *Belt drives — Classical and narrow V-belts — Grooved pulleys (system based on datum width)*

ISO 4871:1996, *Acoustics — Declaration and verification of noise emission values of machinery and equipment*

ISO 4915:1991, *Textiles — Stitch types — Classification and terminology*

ISO 4916:1991, *Textiles — Seam types — Classification and terminology*

ISO 7574 (all parts), *Acoustics — Statistical methods for determining and verifying stated noise emission values of machinery and equipment*

ISO 8239:1987, *Sewing machine needles — Fitting dimensions — Tolerances and combinations*

ISO/CIE 8995:2002, *Lighting of indoor work systems*

ISO 9614-1:1993, *Acoustics — Determination of sound power levels of noise sources using sound intensity — Part 1: Measurement at discrete points*

ISO 9614-2:1996, *Acoustics — Determination of sound power levels of noise sources using sound intensity — Part 2: Measurement by scanning*

ISO 11200:1995, *Acoustics — Noise emitted by machinery and equipment — Guidelines for the use of basic standards for the determination of emission sound pressure levels at a work station and at other specified positions*

ISO 11201:1995, *Acoustics — Noise emitted by machinery and equipment — Measurement of emission sound pressure levels at a work station and at other specified positions — Engineering method in an essentially free field over a reflecting plane*

ISO 11202:1995, *Acoustics — Noise emitted by machinery and equipment — Measurement of emission sound pressure levels at a work station and at other specified positions — Survey method in situ*

ISO 11203:1995, *Acoustics — Noise emitted by machinery and equipment — Determination of emission sound pressure levels at a work station and at other specified positions from the sound power level*

ISO 11204:1995, *Acoustics — Noise emitted by machinery and equipment — Measurement of emission sound pressure levels at a work station and at other specified positions — Method requiring environmental corrections*

ISO/TR 11688-1:1995, *Acoustics — Recommended practice for the design of low-noise machinery and equipment — Part 1: Planning*

ISO 12100-1:2003, *Safety of machinery — Basic concepts, general principles for design — Part 1: Basic terminology, methodology*

ISO 12100-2:2003, *Safety of machinery — Basic concepts, general principles for design — Part 2: Technical principles*

ISO 13849-1:1999, *Safety of machinery — Safety-related parts of control systems — Part 1: General principles for design*

ISO 13852:1996, *Safety of machinery — Safety distances to prevent danger zones being reached by the upper limbs*

ISO 13853:1998, *Safety of machinery — Safety distances to prevent danger zones being reached by the lower limbs*

ISO 13854:1996, *Safety of machinery — Minimum gaps to avoid crushing of parts of the human body*

IEC 60204-1, *Safety of machinery — Electrical equipment of machines — Part 1: General requirements*

IEC 60204-31:2001, *Safety of machinery — Electrical equipment of machines — Part 31: Particular safety and EMC requirements for sewing machines, units and systems*

IEC 60745-1:2003, *Hand-held motor-operated electric tools — Safety — Part 1: General requirements*

IEC 60825-1:2005, *Safety of laser products — Part 1: Equipment classification, requirements and user's guide*

EN 563, *Safety of machinery — Temperatures of touchable surfaces — Ergonomics data to establish temperature limit values for hot surfaces*

3 Terms and definitions

For the purposes of this document, the terms and definitions given in ISO 4915, ISO 4916, ISO 11204, ISO 12100-1 and ISO/IEC Guide 51, and the following apply.

3.1

industrial sewing machine

sewing machine specifically designed for industrial purposes

3.2

sewing machine

machine designed to produce one or more stitches with one or more sewing threads; in producing a seam the machine can perform one or more sewing functions

NOTE 1 See ISO 4915 and ISO 4916 for stitches and seams, respectively.

NOTE 2 Previously, the term “sewing machine head” was used instead of “sewing machine”.

3.3

sewing machine stand

item on which a sewing machine is arranged to enable optimum operation

EXAMPLE Sewing machine stand designed as a table.

3.4

sewing machine drive

equipment that drives a sewing machine, speed-controlled by electrical or mechanical means, or both, either with or without a positioning device and control of machine functions

EXAMPLE Electric motor.

**3.5
sewing unit**

equipment consisting of at least a sewing machine, sewing machine stand and sewing machine drive

NOTE One or more devices incorporated in, or attached to, the sewing machine, sewing unit or both (e.g. for sewing, cutting, feeding the sewing material) are, in addition to the sewing machine itself, controlled either by the operator or automatically.

**3.6
sewing system**

equipment consisting of at least two sewing units or parts of sewing units, functionally interlinked

**3.7
quilting machine**

specialty constructed sewing unit or sewing system designed for use in the upholstery industry

EXAMPLES Tape edge machine, multi-needle sewing machine, long-arm quilting machine, tacking machine.

**3.8
sewing tool exchange and adjustment**

threading a needle, looper, spreader, or changing a presser foot, bobbin, needle plate, sewing machine needle, or action such as cleaning

**3.9
multihead embroidery machine**

sewing system that allows two or more embroidery heads to be modularly linked together

**3.10
sewing area**

effective range around sewing machine needle between needle plate and the upper turning point of the needle movement

**3.11
finger deflecting device**

means of preventing access of fingers into the danger zone of the sewing area

**3.12
cutter system**

devices for cutting sewing threads, tape or sewing material

**3.13
auxiliary equipment**

additional device that assists in handling procedures

4 Significant hazards

4.1 General

This clause contains all the significant hazards, hazardous situations and events, as far as they are dealt with in this International Standard, identified by risk assessment as significant for this type of machine and which require action to eliminate or reduce the risk. Before using this International Standard it is important to carry out a risk assessment of the machine to check that its hazards are those identified in this clause.

Danger zone or hazardous situation	Type of hazard	Corresponding reference (see Clauses 5 and 7)
4.2 Mechanics		
4.2.1 Sewing area (Zone I): movements of the		
a) sewing machine needle,	stabbing or puncture	5.2.1.1, Annex A
b) cutter system,	cutting or severing	5.2.1.2, Annexes B and L
c) feeding system,	crushing, shearing, drawing-in or trapping	5.2.1.3
d) shuttle/hook/looper assembly, or	drawing-in or trapping, impact, stabbing or puncture	5.2.1.4, 5.2.2.3, Annexes B and L
e) movement due to sewing tool exchange and adjustment — unintentional operation of the pedal when the machine is not switched “OFF” or during last runnings.	crushing, trapping, shearing, impact	5.2.1.5, Clause 7, Annexes B and L
4.2.2 Sewing machine (Zone II): movement of the		
a) needle bar, or	impact	5.2.1.6
b) thread take-up lever for needle thread, looper thread, etc.	impact	5.2.1.7
4.2.3 Drive (Zone III):		
a) handwheel,	drawing-in or trapping	5.2.1.8
b) pulley/belt drive at sewing machine,	drawing-in or trapping, severing	5.2.1.9, Annexes E and F
c) pulley/belt drive at sewing machine drive (motor).	drawing-in or trapping, severing	5.2.1.10, Annex E, F and H
4.2.4 Tilting area: falling down/out of the uptilted machine by gravity.	crushing, shearing	5.2.1.11, Clause 7
4.2.5 Auxiliary equipment: for example, additional feeding, folding, transfer, separating, stacking system at automated sewing systems.	crushing, shearing, entanglement, drawing-in or trapping, impact	5.2.1.12

Danger zone or hazardous situation	Type of hazard	Corresponding reference (see Clauses 5 and 7)
<p>4.3 Electricity/Control</p> <p>4.3.1 Electrical contact (direct or indirect), caused by</p> <p>a) component failure, b) insulation failure, or c) incorrect design, installation or component specification of the electrical equipment.</p> <p>4.3.2 Functional disorders:</p> <p>a) failure of control system (e.g. malfunction of safety devices, unexpected start), b) irregularity of energy supply (e.g. loss, recurrence, fluctuation).</p> <p>4.3.3 Electrostatic phenomena</p> <p>4.3.4 External influences (e.g. EMC)</p>	<p>electric shock or burns electric shock or burns burns</p> <p>all possible hazards generated by unexpected dangerous movements</p> <p>sudden fright caused by electrostatic discharge</p> <p>unexpected dangerous movement</p>	<p>5.2.2.1</p> <p>5.2.2.1, 5.2.2.2, 5.2.2.4 to 5.2.2.13, Annex G</p> <p>5.2.2.14</p> <p>5.2.2.15</p>
<p>4.4 Thermal hazards</p> <p>Accidental contact with hot surfaces:</p> <p>a) sewing lamp head (needle light); b) drives (e.g. motors); c) machine surface.</p>	<p>burns</p>	<p>5.2.3</p>
<p>4.5 Noise</p> <p>Drive or transmission.</p>	<p>temporary or permanent loss of hearing; other physiological disorders (e.g. loss of balance, loss of awareness); interference with oral message and other acoustical signals</p>	<p>5.2.4, 7.4.1 i), Annexes C, I and J</p>
<p>4.6 Radiation</p> <p>Eye contact with laser marker.</p>	<p>temporary or general loss of eyesight</p>	<p>5.2.5, Clause 7</p>

Danger zone or hazardous situation	Type of hazard	Corresponding reference (see Clauses 5 and 7)
<p>4.7 Ergonomics</p> <p>This covers</p> <p>a) unhealthy posture (e.g. chair, height of chair and sewing table),</p> <p>b) inadequacy with human hand, arm or foot, leg anatomy (e.g. arm position while sewing, knee actuator for presser foot lifting),</p> <p>c) inadequate local lighting (e.g. bad visibility in sewing area), and</p> <p>d) unhealthy exposure to the jet of air from pneumatic equipment or cooling air from a motor</p>	<p>risk of occupational disease, accelerated fatigue, posture diseases</p> <p>accelerated fatigue</p> <p>eye strain</p> <p>cold, muscle strain</p>	<p>5.2.6, Annex L</p> <p>5.2.6.3</p>
<p>4.8 Special hazards</p> <p>4.8.1 Button sewing machine, buttonhole sewing machine, bartacking machine, programmable pattern sewing machine:</p> <p>— ejection of parts (e.g. splinted or broken sewing machine needle)</p> <p>4.8.2 Quilting machine</p> <p>4.8.3 Bag closing sewing machine</p> <p>4.8.4 Embroidery machine</p> <p>4.8.5 Glove sewing machine</p> <p>4.8.6 Sewing machine for shoe repair</p> <p>4.8.7 Blind stitch sewing machine</p> <p>4.8.8 Linking machines</p>	<p>facial injuries (especially eyes), caused by stabbing or puncture</p> <p>drawing-in</p> <p>drawing-in</p> <p>drawing-in</p> <p>stabbing or puncture</p> <p>stabbing or puncture</p> <p>stabbing or puncture</p> <p>stabbing or puncture</p>	<p>5.3.1, Annex D</p> <p>5.3.2</p> <p>5.3.3</p> <p>5.3.4</p> <p>5.3.5</p> <p>5.3.6</p> <p>5.3.7</p> <p>5.3.8</p>

4.9 Danger zones

Figures 1 to 7 show different types of industrial sewing machines, indicating the danger zones and some details of construction. These figures are shown for information only.

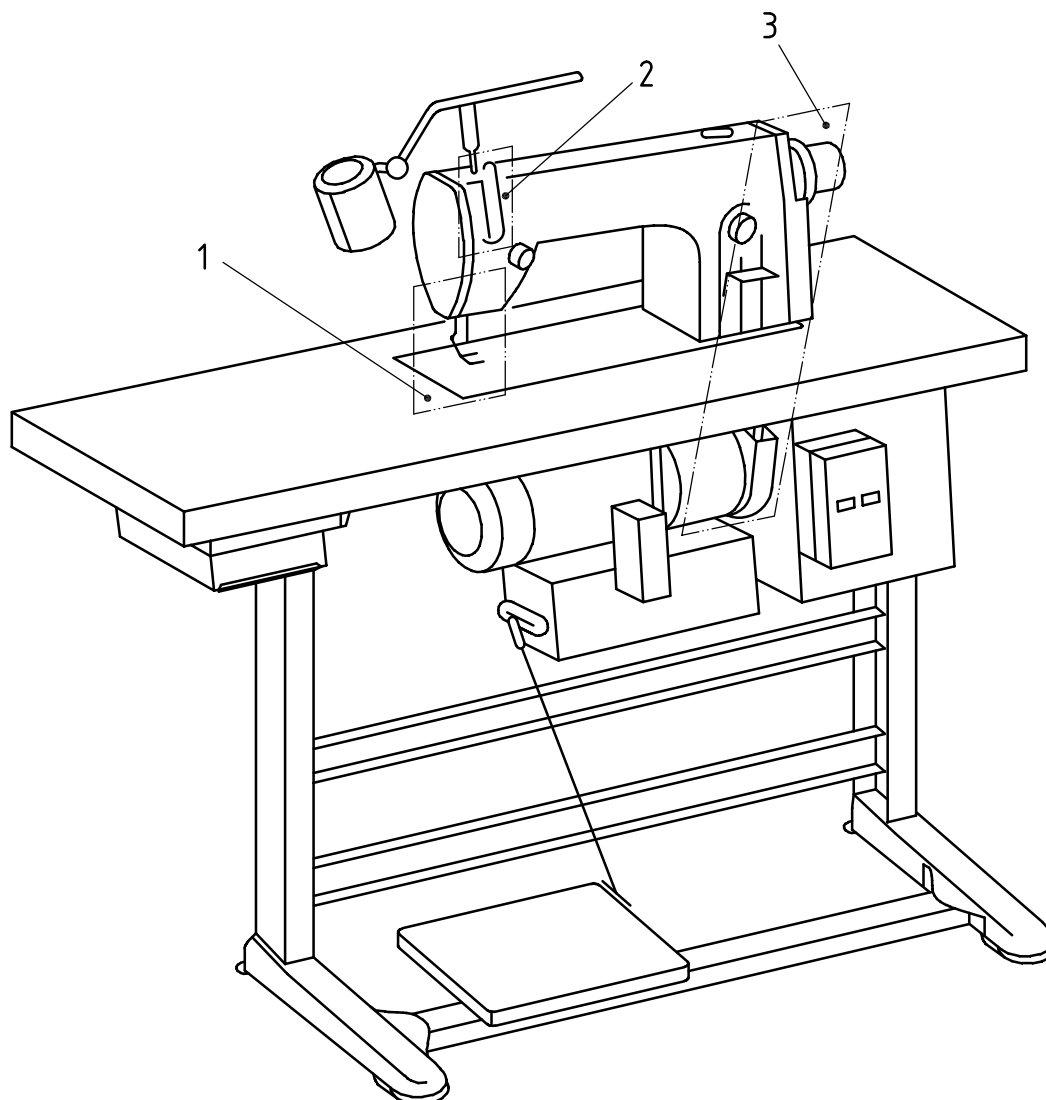

Key

- 1 zone I
- 2 zone II
- 3 zone III

Figure 1 — Danger zones — Mechanics (see 4.2)

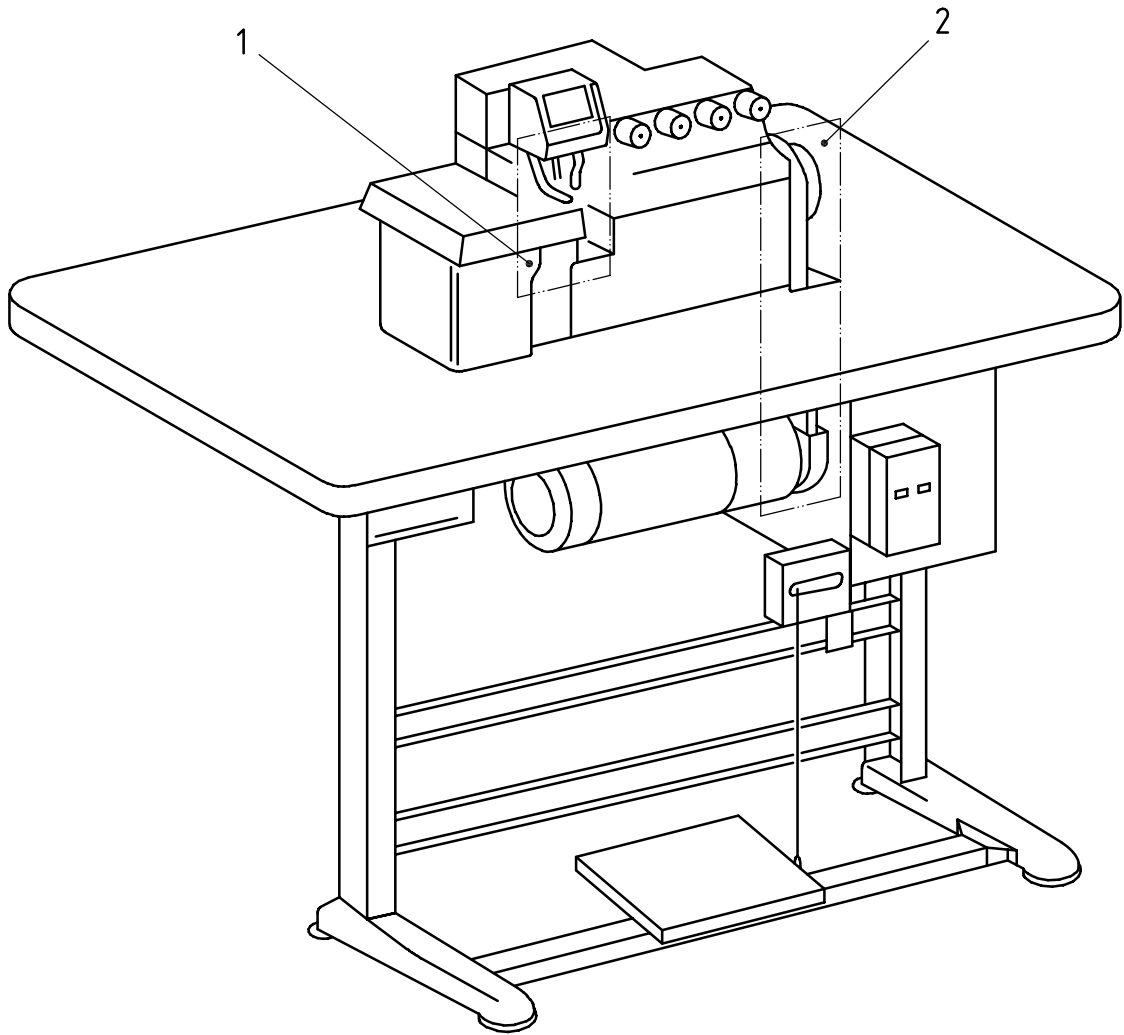

Key

- 1 zone I
- 2 zone III

Figure 2 — Danger zones — Mechanics (see 4.2)

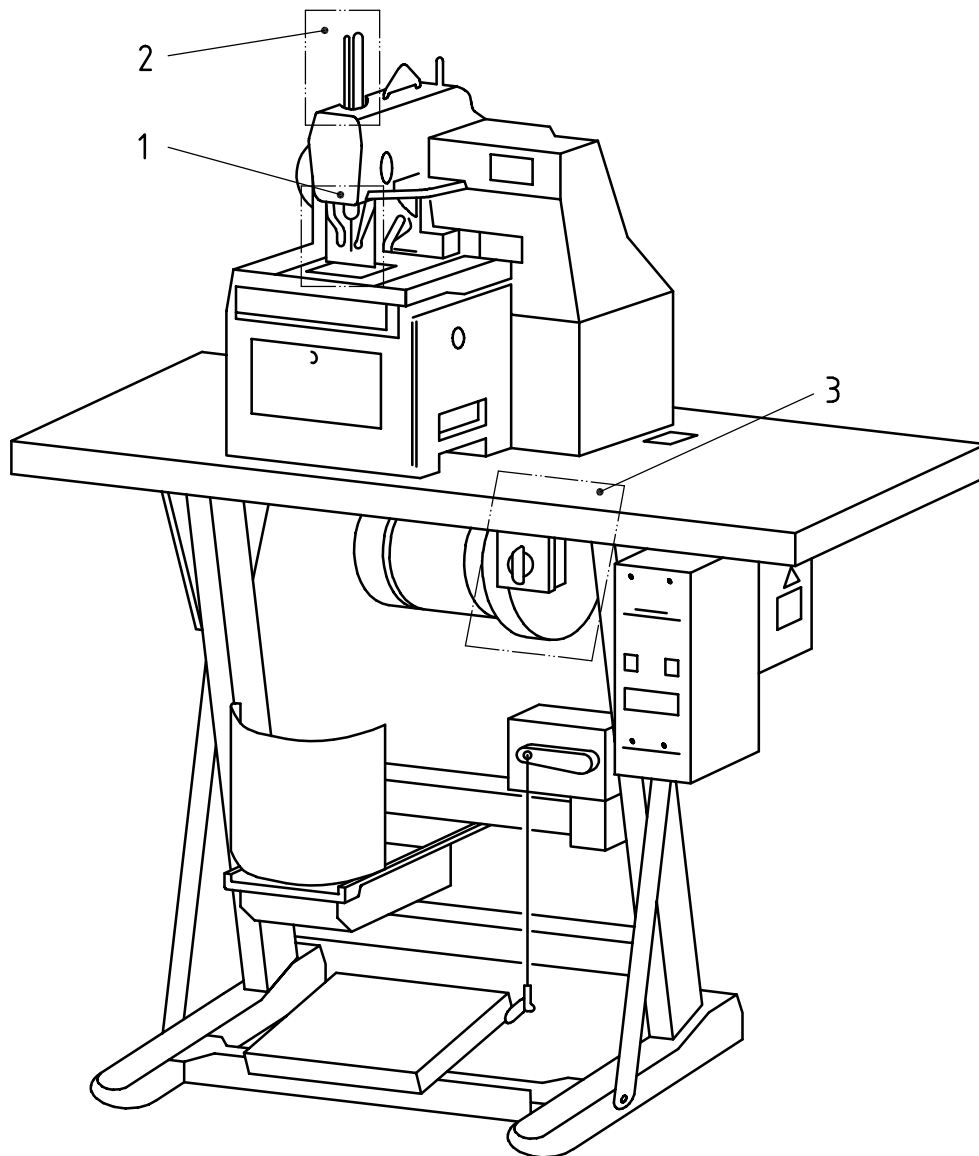

Key

- 1 zone I
- 2 zone II
- 3 zone III

Figure 3 — Danger zones — Mechanics (see 4.2)

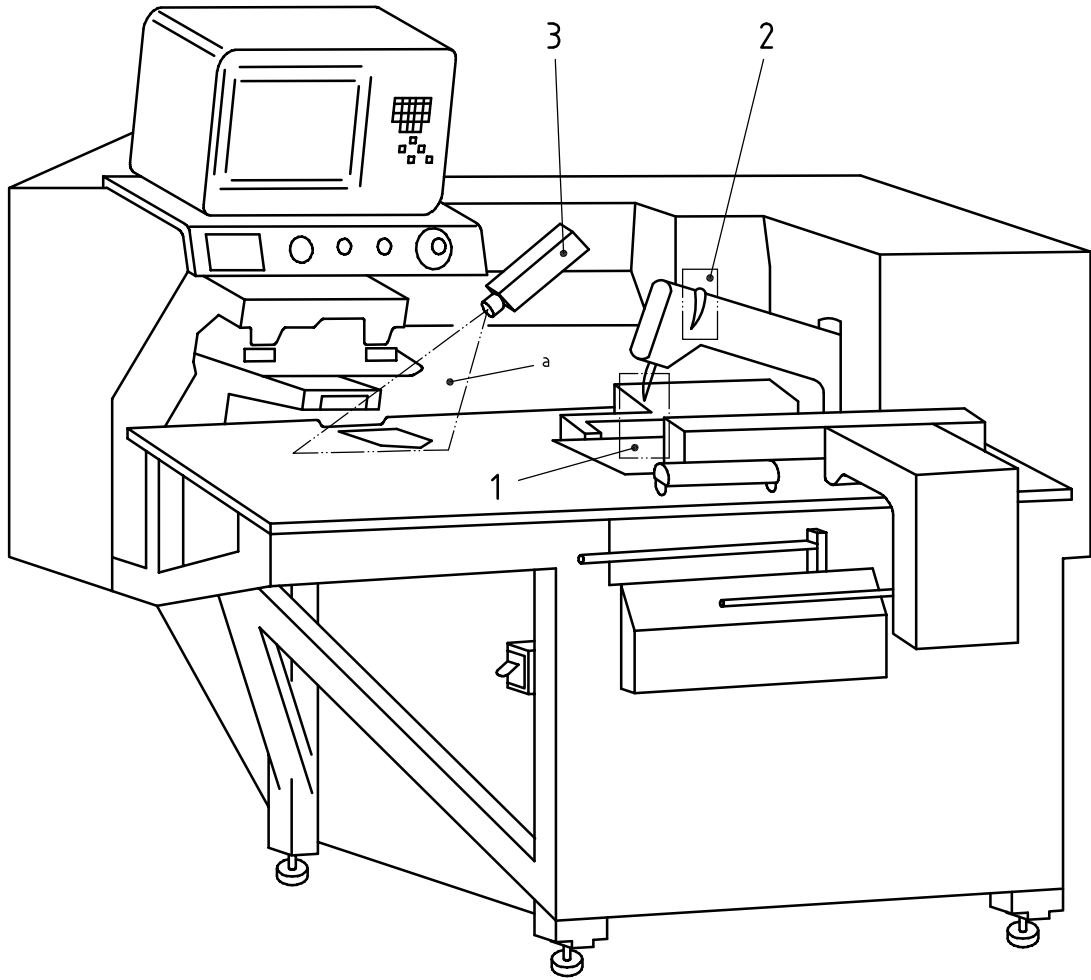

Key

- 1 zone I
- 2 zone II
- 3 laser ^a
- ^a See 4.6.

Figure 4 — Danger zones — Mechanics and radiation (see 4.2 and 4.6)

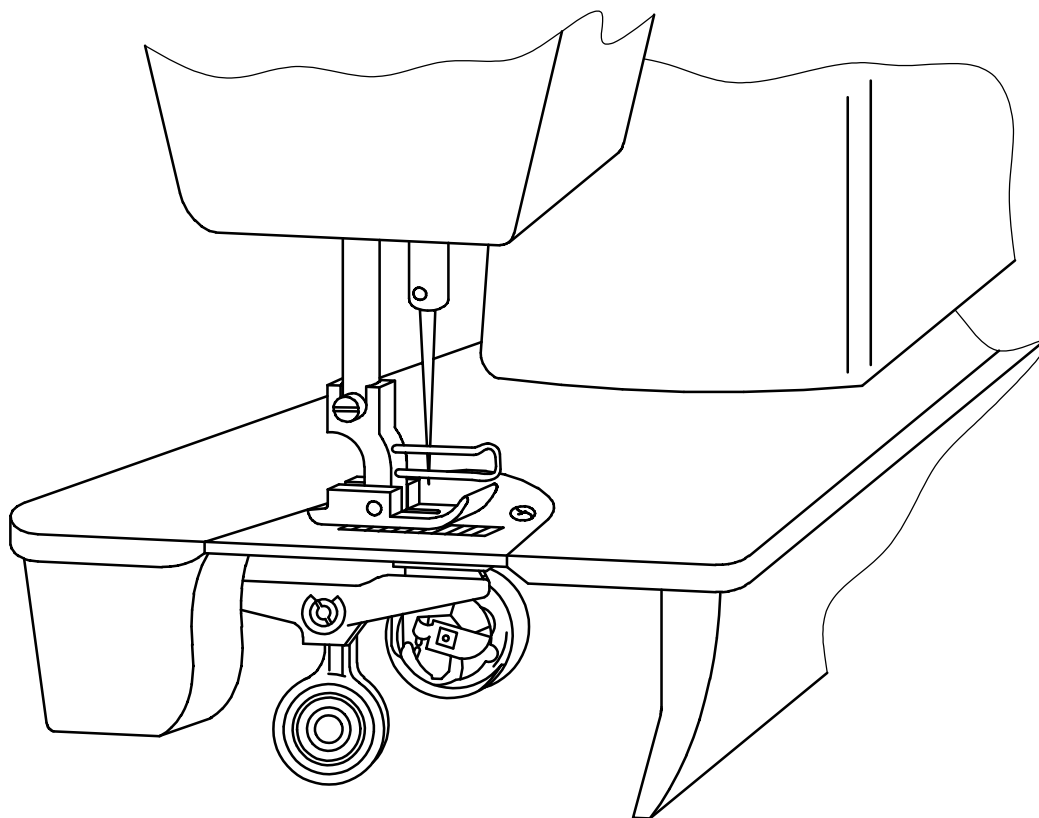

Figure 5 — Danger zones — Zone I (see 4.2.1): hook with horizontal axis

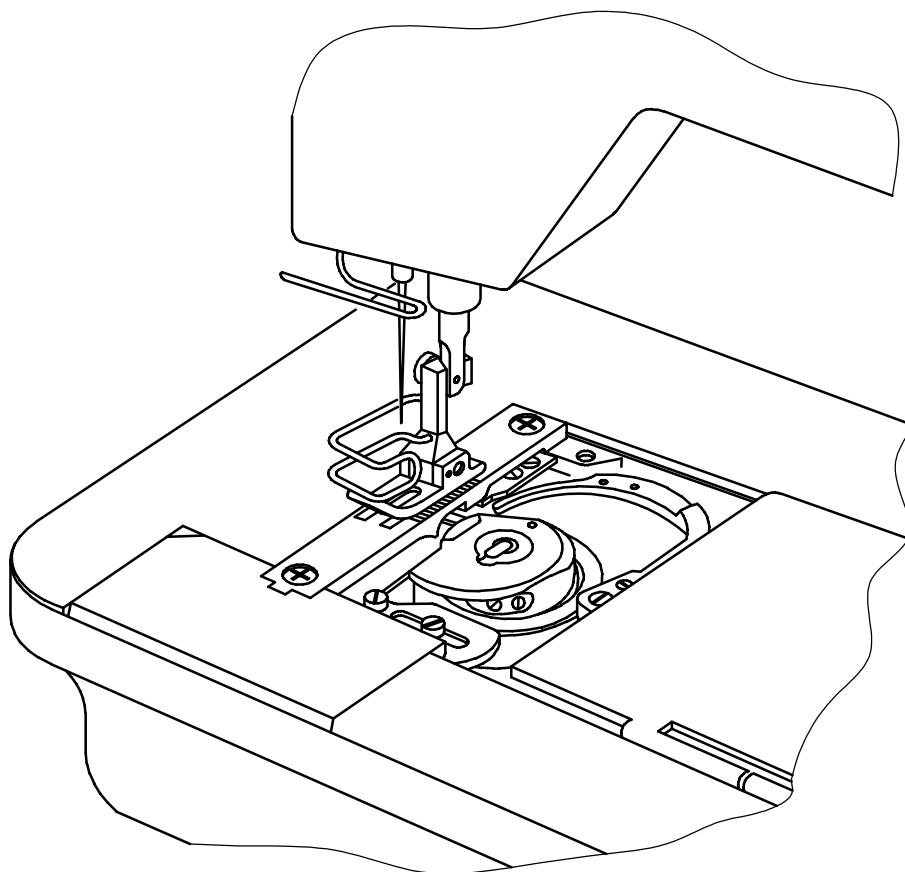
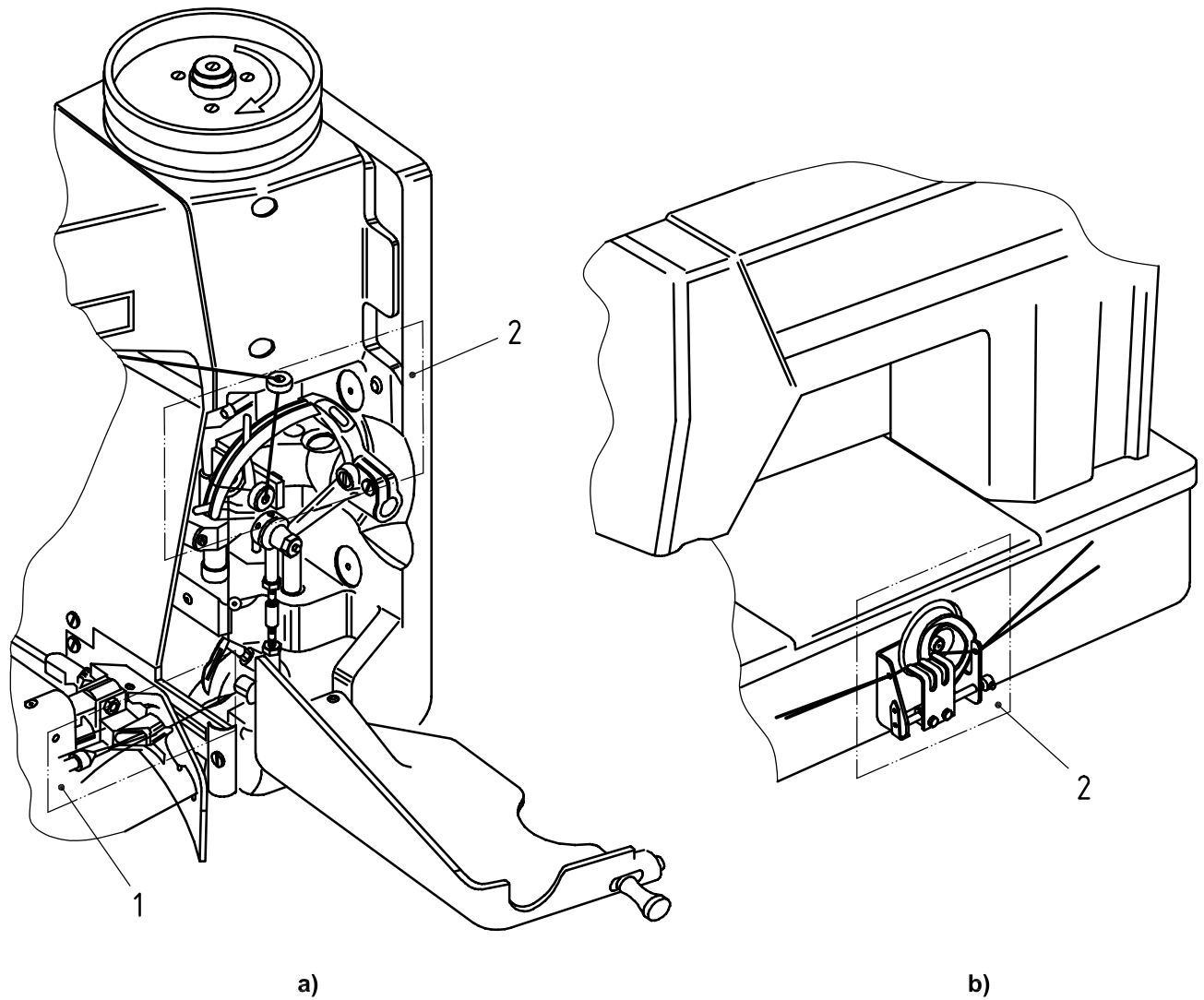

Figure 6 — Danger zones — Zone I (see 4.2.1): hook with vertical axis



Key

- 1 zone I
- 2 zone II

Figure 7 — Danger zones — Zone I (see 4.2.1): looper; Zone II (see 4.2.2): thread take-up

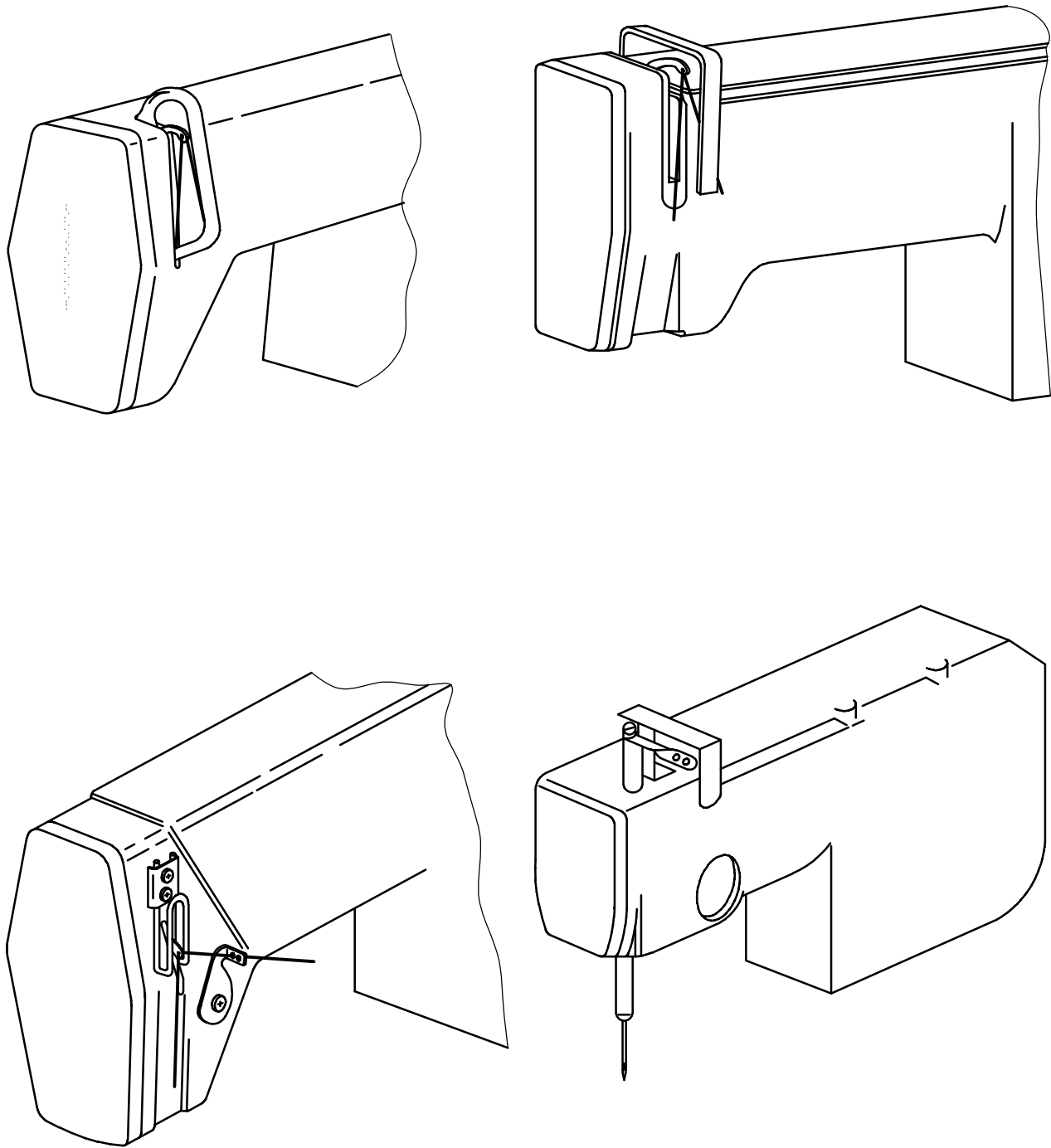

Figure 8 — Danger zones — Zone II (see 4.2.2): thread take-up

5 Safety measures and requirements

5.1 General principles

5.1.1 Sewing machines, units and systems shall comply with the safety requirements and/or protective measures of this clause (and of Clause 7). In addition, they shall be designed according to the principles of ISO 12100 for hazards relevant but not significant, which are not dealt with by this document (e.g. sharp edges).

5.1.2 Gaps between moving surfaces shall not exceed 8 mm where there exists a risk of trapping, severing, crushing or shearing. One possible solution for ensuring the safety of the machines is the provision of safety distances that prevent danger zones from being reached which are in accordance with ISO 13852, ISO 13853 and ISO 13854.

5.1.3 Safeguarding techniques are not required if the maximum force of a moving part is limited to 50 N and the contact pressure to 50 N/cm².

5.2 Requirements for all types of industrial sewing machines

5.2.1 Mechanical equipment

5.2.1.1 Sewing machine needle

Unless otherwise required for particular machine types in other clauses of this document, hazards caused by needle movement shall be eliminated by means of a safeguard device. This requirement is considered to have been met when a finger-deflecting device is used, or when the position of the needle in relation to other devices mounted on the sewing machine (roller foot, spreader, looper, needle cooling tube, feed-in devices, angular tape guide, binder etc.) prevents access of fingers to the sewing machine needle (see Annex A).

Needle breakage protection is only required for specific machines as specified in 5.3.1.

5.2.1.2 Cutter system

The cutter systems such as sewing thread, tape or sewing material cutting device should be designed so that the opening width of the cutter is limited to less than 8 mm. When, due to the sewing operation (e.g. sewing of quilted material), the opening width exceeds 8 mm, this shall be indicated in the instructions (see Clause 7), and, in addition, Form A of the warning sign in accordance with Figure B.1 or ISO 3864:1984, Figure B.3.1, shall be affixed in or near the danger zone. This applies, for example, to lining stitch-in machines in the shoe industry, to sewing units for thick material in the upholstery industry and to bag closing sewing machines in the packaging industry (see 5.3.3), and to other cases where the specific sewing operation does not allow the use of a protective device.

5.2.1.3 Feeding area

The instructions (see Clause 7) shall contain information on the correct use of hazardous feeding elements which cannot be safeguarded completely.

NOTE Feeding elements such as a feed dog, feeding chain, presser foot, roller foot and puller feed generally involve low risk.

5.2.1.4 Shuttle/hook/looper assembly

Hazards caused by movements of stitch forming and thread guiding means shall be eliminated by guards such as casings or covers as far as the sewing process allows (see examples in Figures 7 and 8). The casings/covers need not be interlocked with the sewing machine drive and at the same time will be able to be opened without any tools (see also 5.2.2.3).

To prevent injury during threading, changing bobbins or needles, cleaning, etc., Form B or C of the warning sign according to Annex B (see Clauses B.3 and B.4), shall be affixed in or near the danger zone.

5.2.1.5 Sewing tool exchange and adjustment

To enable safe threading, changing of bobbin, looper or needle, cleaning, etc., a main switch in accordance with IEC 60204-31:2001, 5.3, shall be installed.

Warning sign, Form B or C (see Clause B.3 or B.4), shall be affixed according to Annex B.

5.2.1.6 Top of needle bar

The operator shall be protected against impact by the top of the needle bar. Guards such as a bow or stake are suitable (see examples in Figure 8).

5.2.1.7 Thread take-up lever for needle thread, looper thread, etc.

A guard against an impact hazard, such as a cover, bow or stake, shall be provided (see examples in Figure 8). Movable guards need not be interlocked with the sewing machine drive and will be able to be opened without tools (see also 5.2.2.3).

This requirement does not apply to machines with slow operating speeds (< 500 stitches per minute, e.g. shoe-repairing machines).

5.2.1.8 Handwheel

Any accessible area on rotating handwheels not fully covered while sewing shall be smooth and shall not have spokes, hazardous openings exceeding 8 mm, protrusions or webs.

The main direction of rotation shall be clearly and visibly marked on the sewing machine (e.g. within the hand wheel area, see Figure 9).

5.2.1.9 Pulley/belt drive at sewing machine

If the power transmission from motor to handwheel is obtained by an externally running belt, the belt intake point shall be guarded to avoid injury to the operator's fingers [see Figure 9 and Figure E.1a)].

If the distance between the belt and the border of the table top opening exceeds 8 mm, a belt guard shall be provided to reduce the distance to 8 mm or less (see Figure 9 as an example of complete guarding).

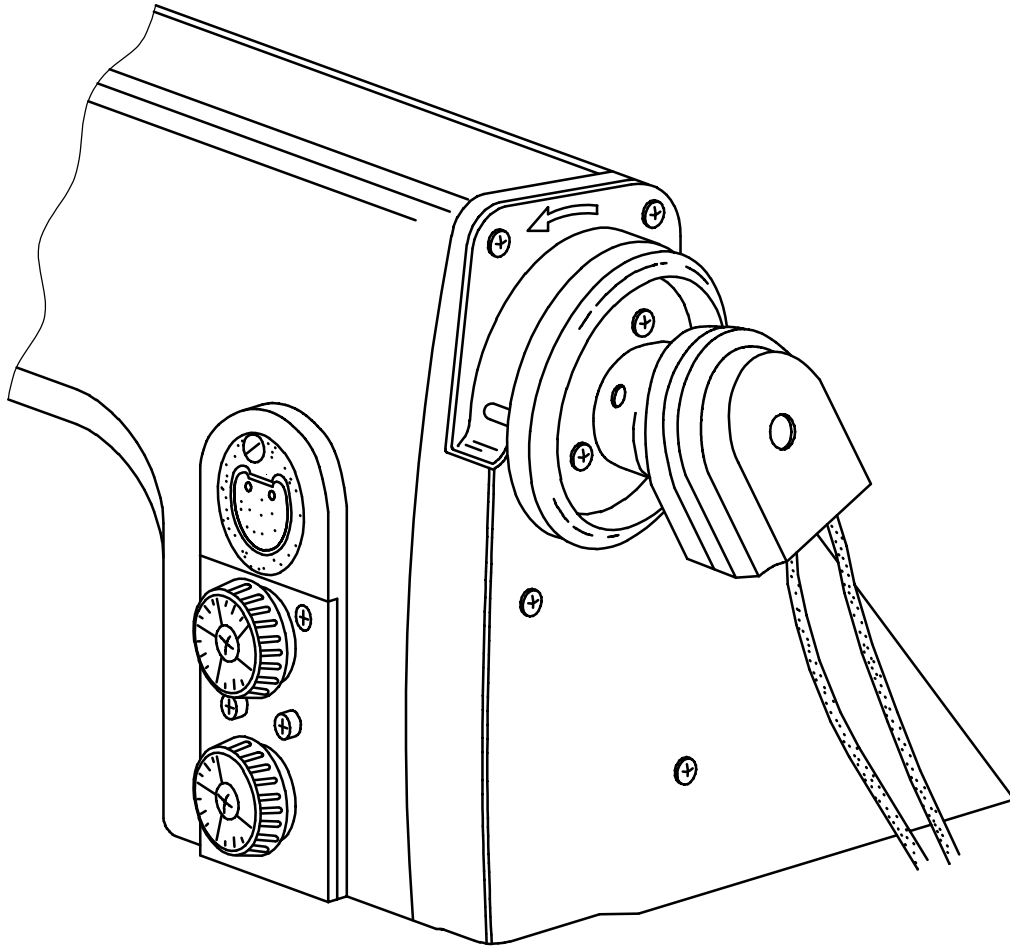

Figure 9 — Example of belt guard

5.2.1.10 Pulley/belt drive at sewing machine drive (motor)

The belt intake point at the pulley of the sewing machine drive shall be guarded so that fingers cannot reach the danger area. This requirement is met when the guard satisfies the requirements of Annex E.

In order to prevent the belts falling off the belt pulley when the sewing machine is being tilted or lowered, a device according to Annex E shall be provided.

NOTE 1 Due to the frequent motor actuation required and, consequently, the high load of the belt pulleys, belt pulleys and drive shafts with taper fit should be used (see Annex F).

NOTE 2 For safe mounting of sewing machine drives, the requirements of Annex H should be followed.

5.2.1.11 Tiltable sewing machines

The sewing machine shall be secured in the frame or table so that, when tilted, it cannot fall out or accidentally drop back.

This requirement is considered to have been met if, for example, the tilted position of the sewing machine is stable or if a locking device is available.

Further information shall be given in the instructions (see Clause 7).

5.2.1.12 Auxiliary equipment

Considering the diversity of possible auxiliary equipment, the manufacturer shall carry out a risk assessment for defining the required safety measures, taking account of the following.

On auxiliary equipment such as additional feeding, folding, binding, transfer, separating and stacking systems, access to crushing and shearing points shall be prevented by guards, e.g. fencing, covers.

Swivel, flip-over and roll type stackers used on sewing units or sewing systems shall be secured by deterring or impeding devices such as bows or stakes.

5.2.1.13 Stability of the sewing unit

The sewing unit shall be stable in a tilting range of 15° based on a horizontal floor.

5.2.2 Electrical equipment/control/control gear

5.2.2.1 General

Electrical systems and equipment for industrial sewing machines shall be in accordance with IEC 60204-31.

All operator-related controls requiring adjustment for changing the working process shall be located outside the electric cabinet.

Machines with several operating modes shall be equipped with a mode-selection device that indicates the mode (e.g. automatic operation, hand-controlled operation, adjustment).

NOTE In general, for sewing machines the different operating modes do not present different safety levels.

In general, on sewing units and systems on which the hazardous movement of parts is limited to parts of the sewing machine itself (e.g. stitch forming elements, feed) protective interlocking is not required.

5.2.2.2 Redundancy/diversity

On sewing units and systems on which the hazardous movement of parts is limited to parts of the sewing machine itself (e.g. stitch-forming elements, feed), provision of redundancy or use of diversity is not required (see 5.2.2.13).

5.2.2.3 Movable protection device

Movable protection devices (e.g. needle plate, bed slide, cover for stitch forming and thread-guiding elements) need not be linked to any safety control system (see 5.2.1.4).

5.2.2.4 Starting conditions for automatic start-up by closing a movable or sensitive protection device

The automatic start-up of automatically or semi-automatically operated sewing units or systems shall be achieved by one of the following:

- for machines requiring an intervention within the danger zones during each sewing cycle, by closing of the protective guard or clearing the danger zone at the least;
- for machines requiring occasional intervention into danger zones, by the additional actuation of a push button.

5.2.2.5 Starting conditions for sewing units

For sewing units having no hazardous movements other than those of the stitch-forming elements, the sewing operation may be initiated by a sensor system (light barrier, air flow barrier, feeler, etc.) actuated by the sewing material. If a unit has different starting modes, where starting is by a sensor system, a visual indication such as a lamp shall be provided.

5.2.2.6 Means for actuating a sewing unit

Manual controls that create hazardous movement shall be protected against unintended actuation, e.g. push buttons with safety collars. This does not apply to the sewing machine treadles, which are firmly connected to the machine, as the sewing process consists of a series of start/stop actions during which the sewing material is guided manually while the sewing machine treadles are actuated by foot.

5.2.2.7 Positioner/synchronizer

Safe fastening of an adaptable positioner or synchronizer is required in order to avoid malfunctions of control. An example of safe mounting is given in Annex G.

5.2.2.8 Supply of electric power

The requirements of IEC 60204-31 are applicable.

5.2.2.9 Unintentional restart

Sewing units and systems shall have a device for avoiding an unintentional restart after a supply interruption or voltage reduction and subsequent restoration. A starting control device with automatic resetting (e.g. pedal) and which is stopped by its release is considered to be an acceptable solution.

5.2.2.10 Devices for prevention of accidental operation

Operating elements of pedal switches which could actuate hazardous movements and which are not firmly connected with the machine, as well as pedal switches on stand-up workstations, shall be safeguarded against accidental operation.

This requirement is considered to have been met by, for example, provision of a tunnel-like shroud around the pedal switch.

5.2.2.11 Loss of memory

On industrial sewing machines that are unable to be switched off owing to, for example, loss of memory, other measures such as threading stop or maintenance stop shall be taken to make the machine secure during access into danger zones (during threading, changing needles, etc.).

5.2.2.12 Stop

“Stop” functions shall be in accordance with IEC 60204-31:2001, 9.2.5.3. Emergency stop devices shall be provided according to the requirements of IEC 60204-31:2001, 10.7.5.

5.2.2.13 Safety-related parts of control systems

Where the significant hazards originate mainly from stitch-forming elements, Category B of ISO 13849-1:1999 is applicable for industrial sewing machines.

Other types of industrial sewing machines shall be in accordance with Category 1 of ISO 13849-1:1999.

5.2.2.14 Electrostatic phenomena

The detailed requirements given in IEC 60204-31:2001, 8 and 15.2.4 are applicable.

5.2.2.15 Electromagnetic compatibility (EMC)

The detailed requirements given in IEC 60204-31 are applicable.

5.2.3 Thermal requirements

Hot surfaces located within the working area and not directly required for the working process shall be safeguarded against accidental contact.

This requirement is considered to have been met when, for example, the hot contact surfaces are protected by means of insulation materials or additional covers so that the maximum surface temperature does not exceed the values specified in EN 563, which include

- 65 °C on uncoated metal surfaces,
- 85 °C on plastic surfaces, and
- 110 °C on wooden surfaces.

Materials containing asbestos shall not be used for the purpose of insulation.

If none of these requirements are able to be met, a warning sign shall be affixed indicating hot machine parts in or near the danger zone. Further information shall be given in the instructions (see Clause 7).

5.2.4 Noise

5.2.4.1 Noise reduction at the design stage

Industrial sewing units or systems shall be designed, constructed and installed so that risks resulting from the emission of airborne noise are reduced to the lowest level, taking account of technical progress and the availability of means of reducing noise, in particular at its source.

A non-exhaustive list of technical measures for reducing noise at source is given in Annex J.

When designing the machine, the general rules for the design of low-noise machines given in ISO/TR 11688-1 shall be taken into account.

NOTE ISO/TR 11688-2 gives useful information on noise generation mechanisms in machines.

5.2.4.2 Measurement and declaration of noise emission

Noise emission of the sewing units and systems covered by this International Standard shall be indicated in the instructions (see Clause 7) by the declared noise emission levels expressed in decibels.

Testing shall be conducted to quantify the industrial sewing machine's airborne noise emissions, either with the actual value of an individual machine or a value established on the basis of measurements made on identical machines.

a) For machines with a defined workstation, measure and declare the following:

- the equivalent continuous A-weighted emission sound pressure level, L_{pA} , at workstations, (corrected e.g. in accordance with ISO 11204 using background noise correction K_{1A} and environmental correction K_{3A} , both expressed in A-weighted decibels), measured at the workstation where this

exceeds an A-weighted value of 70 dB (it shall be indicated if the level does not exceed this value), and in addition, if relevant,

- the impulsive noise, ΔL_1 (see ISO 11204), and, in addition, if necessary,
 - the sound power level, L_{WA} , in decibels, of the machine where L_{pA} exceeds an A-weighted value of 85 dB, or
 - in the case of a very large machine (size of measurement surface $> 50 \text{ m}^2$ [$> 17 \text{ dB}$]), the A-weighted emission sound pressure level, L_{pA} , averaged over a measurement path at 1 m from the surface of the machine and 1,6 m from the floor, instead of L_{WA} .
- b) For machines where the workstation is undefined or cannot be defined, measure and declare the following:
- the maximum emission sound pressure level, $L_{pA, \text{max}}$, (corrected e.g. in accordance with ISO 11204 by background noise correction K_{1A} and environmental correction K_{3A} , both expressed in A-weighted decibels), measured along a path at a distance of 1 m from the surface of the machine and a height of 1,6 m from the floor, where this exceeds an A-weighted value of 70 dB (it shall be indicated if the level does not exceed this value), and, in addition, if available,
 - the impulsive noise, ΔL_1 (see e.g. ISO 11204), and, in addition, if necessary,
 - L_{WA} , in decibels, where L_{pA} exceeds an A-weighted value of 85 dB, or
 - in the case of a very large machine (size of measurement surface $> 50 \text{ m}^2$ $> 17 \text{ dB}$), the A-weighted emission sound pressure level, L_{pA} , averaged over a measurement path at 1 m from the surface of the machine and 1,6 m from the floor, instead of L_{WA} .

The manufacturer shall indicate the operating conditions of the machine during measurement as well as the method or methods used for the measurement.

Examples of noise declarations are given in Annex I.

The measurement and declaration of noise emission values shall be made according to Annex C.

5.2.5 Radiation

5.2.5.1 For light-marking purposes, only laser products of Class 1, 2 or 3A, according to IEC 60825-1:2005, shall be used. The operator shall not view directly with optical appliances any energized fibre end or connector end at a location with a hazard level of 3A. Reflecting surfaces should be avoided within the laser light area.

5.2.5.2 Laser products shall be marked and all relevant information for the user given according to Clauses 5 and 6, respectively, of IEC 60825-1:2005.

5.2.5.3 Written warnings as well as the relevant warning label shall be indicated in the instructions (see Clause 7 of this International Standard).

5.2.6 Ergonomics

5.2.6.1 Under the intended conditions of use, the discomfort, fatigue and psychic stress faced by the operator shall be reduced to a minimum, based on ergonomic principles (see Annex L).

In particular, the design shall take into account and consider

- operating height,
- operator's posture and movement,
- local lighting of the working area, which shall be adequate and required if the general lighting (see 5.2.6.7) is insufficient,
- ease of reach of controls, which shall be appropriate to the machine operation and able to be operated without the need for strength, and
- design and arrangement of displays and signals, which shall be designed, selected and arranged in a manner compatible with the characteristics of human perception.

NOTE See Annex L for further information.

5.2.6.2 Storage devices on working equipment are to be constructed such that the stored objects can neither fall down nor protrude into the operating area, nor otherwise present any danger.

5.2.6.3 The jet of air from pneumatic equipment (e.g. exhaust air jet, directional air current for advancing the fabric) shall be directed or diverted so that neither the operator nor persons at adjacent workplaces are inconvenienced.

The cooling air from a motor shall not be directed onto the operator or persons at adjacent workplaces.

5.2.6.4 The treadle of the pedal shall be non-slip. The operating surface of a knee actuator shall be slideable and even. On seated work stations, the knee actuator shall be adjustable for the operator. These requirements do not apply to knee actuators seldom operated or operated only in the case of disturbance.

5.2.6.5 For seated work stations, the actuating means of the ON/OFF switch shall be mounted between 0,5 m and 1,5 m above the servicing level.

5.2.6.6 For seated work stations, the knee-operated lever (e.g. for lifting the presser foot) shall have an upholstered surface in the operating area.

5.2.6.7 The general lighting (e.g. lighting of indoor work systems) shall meet the requirements of ISO 8995:1989, B.3. If this requirement cannot be met or if special operating conditions are required, local lighting of the sewing area may be necessary. The sewing lamp, if required, shall be operated independently of the position of the device for switching "ON" and "OFF" the sewing unit or sewing system. For the installation of a sewing lamp, the corresponding requirements of IEC 60204-31 shall be met.

Parts that could dazzle the operator by reflecting light should be provided with a matt surface.

5.3 Specific requirements for particular types of industrial sewing machines

5.3.1 Button, buttonhole and programmable pattern sewing machines, bartacking machines

Needle breakage protection shields shall be used on industrial sewing machines where during sewing a needle breakage can occur due to the specific kind of material sewn (e.g. the sewing of additional pieces such as buttons, buckles, hooks, rings and other metallic or plastic pieces onto the fabric) and where needle breakage may result in injuries. These machines are usually mechanical, cam-controlled machines such as

button sewing machines, buttonhole sewing machines, programmable pattern sewing machines using clamping systems and bartacking machines.

This requirement is considered to have been met when needle breakage protection shields as specified in Annex D are used.

5.3.2 Quilting machines

5.3.2.1 General

The electrical equipment for quilting machines (sewing units and systems) shall be in accordance with IEC 60204-1.

5.3.2.2 Multi-needle machines (several needle bars)

Multi-needle machines shall be provided with a threading stop or maintenance stop that allows the machine to be switched off in case of needle or thread breakage or when adjustments are required.

Any unintended start shall be prevented. This requirement is considered to have been met when, for example, the multi-needle machine, after each standstill, can be restarted only by actuating the control device.

Thread cones shall be arranged on the thread stand in such a way as to allow easy access and exchange of the cones. This requirement is considered to have been met when, for example, the thread stand can be reached from the operator's area, or safe steps are provided at the machine.

5.3.3 Bag closing sewing machines in the packaging industry

5.3.3.1 These sewing machines are normally mounted vertically, with the handwheel on top in order to close a bag [see Figure 7 a)], and not horizontally as shown in Figure 1. On bag-closing sewing machines, the area for feeding in the bags or sacks, except for the active operation area, shall be covered by guards.

5.3.3.2 Bag-closing units and systems shall be in accordance with IEC 60204-31. The stop and, respectively, the emergency stop, shall each function as a Category 0 stop according to IEC 60204-1.

5.3.3.3 The electrical equipment for handheld portable machines up to a weight of 10 kg shall be in accordance with IEC 60745-1.

5.3.3.4 See 5.2.1.2 for the corresponding requirements for cutter systems.

5.3.4 Embroidery machines

5.3.4.1 Owing to the nature of the sewing process, a needle breakage protection shield (as defined in Annex D), a protective device for needle thread take-up lever or a finger deflecting device (as defined in Annex A) is not required for embroidery machines.

5.3.4.2 One-head embroidery machines are sewing units and shall conform with the safety requirements for industrial sewing machines according to this International Standard and IEC 60204-31.

5.3.4.3 Multihead embroidery machines are sewing systems and shall conform with the safety requirements for industrial sewing machines according to this International Standard, and to IEC 60204-31 with the following modified requirements.

- a) Multihead embroidery machines shall be able to be switched on and off at a main operation panel.
- b) Irrespective of the main operation panel, it is acceptable that a multihead embroidery machine be also capable of being stopped by a separate switching device of Category 2 according to IEC 60204-1.

- c) Multihead embroidery machines shall have an emergency stop according to IEC 60204-1. The emergency stop shall function as a Category 0 or Category 1 stop.

5.3.5 Glove sewing machines

Owing to the nature of the sewing process, a finger deflecting device as specified in Annex A is not required for glove sewing machines.

5.3.6 Sewing machines for shoe repair

Owing to the nature of the sewing process, a finger deflecting device as specified in Annex A is not required for sewing machines for shoe repair. The requirements for the thread take-up lever are given in 5.2.1.7.

5.3.7 Blindstitch sewing machines

Owing to the nature of the sewing process, a finger deflecting device as specified in Annex A is not required for blindstitch sewing machines.

5.3.8 Linking machines

Owing to the nature of the sewing process, a finger deflecting device as specified in Annex A is not required for linking machines.

6 Verification of safety requirements or measures

Verification shall be carried out by the manufacturer. The manufacturer may subcontract this verification to a third party, but the manufacturer shall remain the responsible party.

The verification of the safety requirements according to Clauses 5.2 and 5.3 shall be made in accordance with Table 1.

Table 1 — Verification methods

Safety requirements according to this International Standard (subclause)	Verification methods			Other International Standards for reference
	Visual inspection	Functional testing	Measurement	
5.2.1.1	X	X	X	
5.2.1.2	X		X	
5.2.1.3	X			
5.2.1.4	X			
5.2.1.5	X			
5.2.1.6	X			
5.2.1.7	X			
5.2.1.8	X	X		
5.2.1.9	X		X	
5.2.1.10	X	X	X	
5.2.1.11	X	X		
5.2.1.12	X			
5.2.1.13		X	X	
5.2.2.1	X	X	X	IEC 60204-31
5.2.2.4		X		
5.2.2.5	X	X		
5.2.2.6		X		
5.2.2.7	X	X		
5.2.2.8	X		X	IEC 60204-31
5.2.2.9		X		
5.2.2.10	X	X		
5.2.2.11		X		
5.2.2.12		X		IEC 60204-31
5.2.2.13	X			ISO 13849-1
5.2.2.14		X	X	IEC 60204-31
5.2.2.15		X	X	IEC 60204-31
5.2.3	X	X	X	
5.2.4	X	X	X	
5.2.5	X	X	X	IEC 60825-1
5.2.6	X	X		
5.3.1	X	X		
5.3.2.1		X	X	IEC 60204-1

Table 1 (continued)

Safety requirements according to this International Standard (subclause)	Verification methods			Other International Standards for reference
	Visual inspection	Functional testing	Measurement	
5.3.2.2	X			
5.3.3.1	X			
5.3.3.2		X		IEC 60204-31
5.3.3.3		X		IEC 60745-1
5.3.3.4	X		X	
5.3.4.2	X	X		IEC 60204-31
5.3.4.3	X	X		IEC 60204-1
5.3.6	X			

7 Information on use and maintenance

7.1 General

This may be text, signs, signals, symbols or diagrams, used separately or in combination to convey information to the user of the machine.

Information on use of the machine is an integral part of the supply of the machine and shall comply with of ISO 12100-2:2003, Clause 6.

7.2 Marking

Sewing units and systems shall be marked legibly and indelibly with the following minimum information:

- name and address of the manufacturer;
- mandatory marking¹⁾;
- designation of series or type;
- serial number, if any;
- year of construction;

For the marking of the electrical equipment, these shall be in accordance with IEC 60204-31.

Further markings should be in accordance, as far as possible, with the appropriate International Standards, i.e. ISO 7000, ISO 2972 and IEC 60417.

Furthermore, if the manufacturer constructs a machine intended for use in a potentially explosive atmosphere, this shall be marked on the machine.

1) For sewing units and systems intended to be put on the market in the EEA, CE marking as defined in the European applicable directives, e.g. machinery, low voltage, EMC.

7.3 Warning of residual risk

Where risks remain despite all measures adopted, and where potential risks are not evident (e.g. electrical enclosures, bleeding of a pneumatic circuit, hazard in an unseen area), the manufacturer shall provide warnings.

Such warnings should include the use of readily understandable pictograms.

Warnings on the electrical equipment shall be in accordance with IEC 60204-31.

For further information on warnings of residual risks, see International Standards such as ISO 3864 and ISO/IEC Guide 51.

7.4 Instructions

7.4.1 General information

The purpose for which the machine is intended shall be clearly defined in the instructions, which shall contain all directions required to ensure its safe and correct use.

- a) It shall be stated in the instructions that the machine has been designed for
 - foreseeable use,
 - use by trained operators or supervisors, and
 - maintenance.
- b) The instructions shall not compensate for design deficiencies and shall include any drawings and diagrams relevant to safety.
- c) The instructions shall be provided with the machine as an integral part of the supply.
- d) The instructions shall be in accordance, in form and content, with ISO 12100-2:2003, 6.5, except for 6.5.2 b).
- e) The requirements on technical documentation for the electrical equipment in IEC 60204-31 shall be taken into consideration when preparing the instructions.
- f) The instructions shall repeat and explain all the information with which the machine is marked (see 7.2. and 7.3).
- g) Management and operators shall ensure that guards are in place and work properly.
- h) Instructions concerning the periodic maintenance or test of the machine related to safety shall be provided if necessary.
- i) Noise declaration as specified in C.9 shall be included in the instructions and in the technical documentation describing the machine (see Annex I):
 - the noise declaration shall give the information obtained when using the noise test code according to Annex C (see C.9).

7.4.2 Particular information

In addition to the requirements of 7.4.1, the instructions shall, whenever possible and appropriate,

- a) give an indication if none of the requirements on cutter systems will be met, and of the use of a warning label,
- b) give an indication if none of the requirements on the shuttle/hook/looper assembly will be met, and of the use of a warning label,
- c) instruct the operator in how to thread the machine,
- d) give handling instructions for avoiding the overturning or falling back (tilting) of the machine,
- e) give an indication of the need to always switch off an industrial sewing machine (e.g. by actuating the ON/OFF switch or by disconnecting the plug from the supply) when
 - a sewing tool exchange and adjustment occurs,
 - the workplace is left unattended, or
 - maintenance work has to be performed, and

in the case of mechanically-actuated clutch motors, give an indication of the need to wait for standstill of the motor,

- f) provide advice that the sieve of the air cooling supply at the sewing machine drive is to be cleaned periodically (to be fixed), and that the industrial sewing unit or system may never be operated with any cooling openings blocked,
- g) provide a warning that an industrial sewing unit or sewing system must always be unplugged from the local lighting of the sewing area before relamping; the marking of maximum rated input of a lamp shall be easily discernible while the lamp is being replaced, indicated on or near the lamp socket by

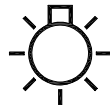

Lamp max ... W,

or

maximum ... W,

- h) give an indication if none of the requirements for hot surfaces will be met, and of the use of a warning label, and
- i) give an indication if machines are equipped with laser products (see 5.2.5), and of the use of a warning label,
- j) give an indication of the fact if the cutter opening width exceeds 8 mm (see 5.2.1.2),
- k) give information on the correct use of hazardous feeding elements (see 5.2.1.3).

Annex A (normative)

Finger deflecting device

A.1 General construction principles

A.1.1 The sewing thread shall be able to be threaded into the eye of the needle without difficulty.

A.1.2 The device shall be constructed so that free sight to the point of stitching is possible and no parts dazzle the operator by reflecting light.

A.1.3 The finger deflecting device shall be an integral part of the sewing tool (e.g. presser foot, collar, clamp). If the finger deflecting device is detachable, then the disassembling shall only be possible using tools.

A.2 Presser foot for lock stitch sewing machines

Construction of a finger deflecting device for the presser foot of a lock stitch machine as shown in Figure A.1 shall be in accordance with the following requirements.

- a) The minimum height shall be 10 mm, measured from the bottom side of the presser foot.
- b) Openings inside the device shall have a diameter not exceeding 9 mm. Slitted openings of any length shall not be wider than 7 mm.
- c) The vertical distance between the needle point at the needle in the threading or stopping position and the effective upper edge of the device while the presser foot is resting on the sewing plane (e.g. needle plate) shall not exceed 4 mm.
- d) The device shall be constructed and fastened so that it can remain active while being acted upon by a force of 20 N.

Dimensions in millimetres

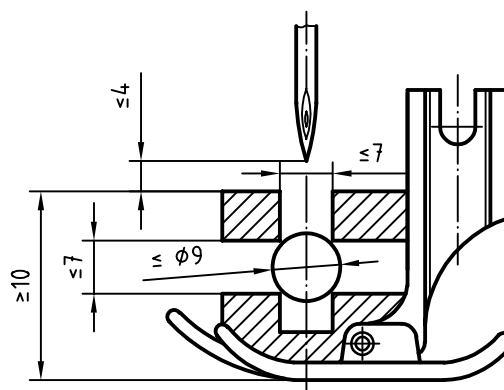

Figure A.1 — Finger deflecting device for lock stitch presser foot

A.3 Construction principle of other presser feet

The construction shall meet the requirements of Clause A.2 in an appropriate manner.

A.4 Examples

Examples of various finger deflecting devices (see A.1, A.2 and A.3) are shown in Figure A.2.

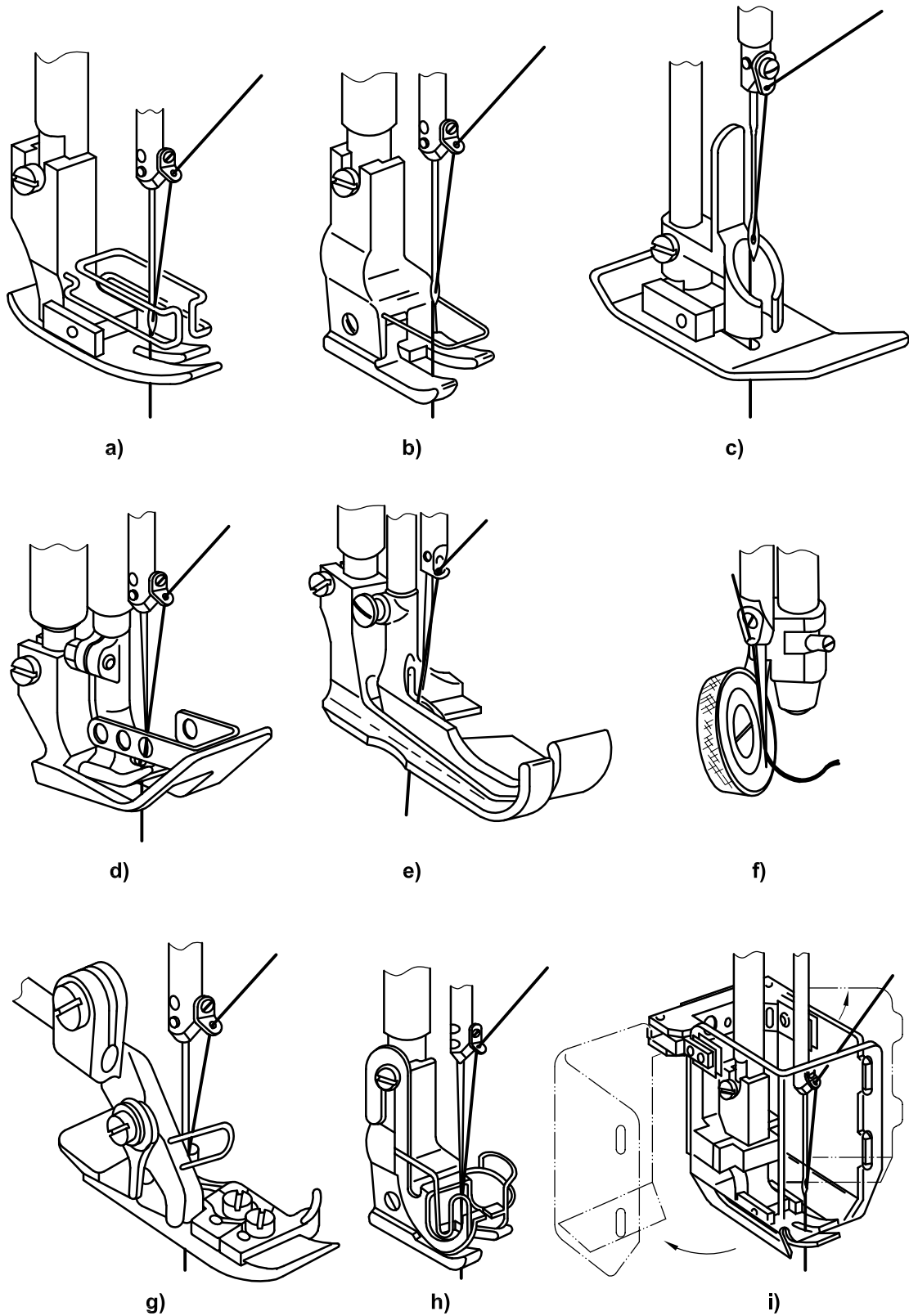

Figure A.2 — Examples of finger deflecting devices

Annex B (normative)

Warning of residual risk

B.1 Warning sign — Form A

This warning sign (see Figure B.1) shall be durably affixed and shall not fade. Shape, configuration and colouring shall be in accordance with ISO 3864. The required dimensions of the warning sign are: $l_1 = 16$ mm, 20 mm, 25 mm, 31,5 mm or 50 mm.

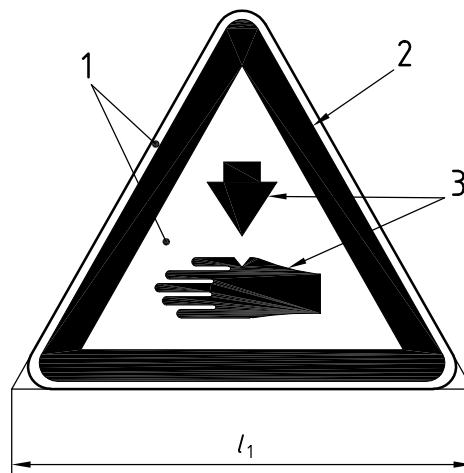

Key

- 1 background colour: yellow
- 2 triangular band: black
- 3 graphic symbol: black
- l_1 see B.1

Figure B.1 — Caution: risk of hand injury

B.2 Written warning

The written warning shall be as follows.

CAUTION — Do not operate without finger guard and safety devices. Before threading, changing bobbin and needle, cleaning, etc., switch off main switch.

The text shall be of a size of no less than 2 mm for capital, and 1,4 mm for lower-case, letters.

For the translation of this written warning into a number of other languages, see Annex K.

B.3 Warning sign, Form B

The text of this warning shall be as shown in Figure B.2, configured with the other elements as shown in Figure B.3.

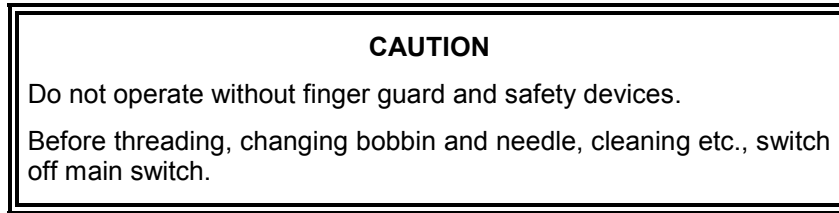
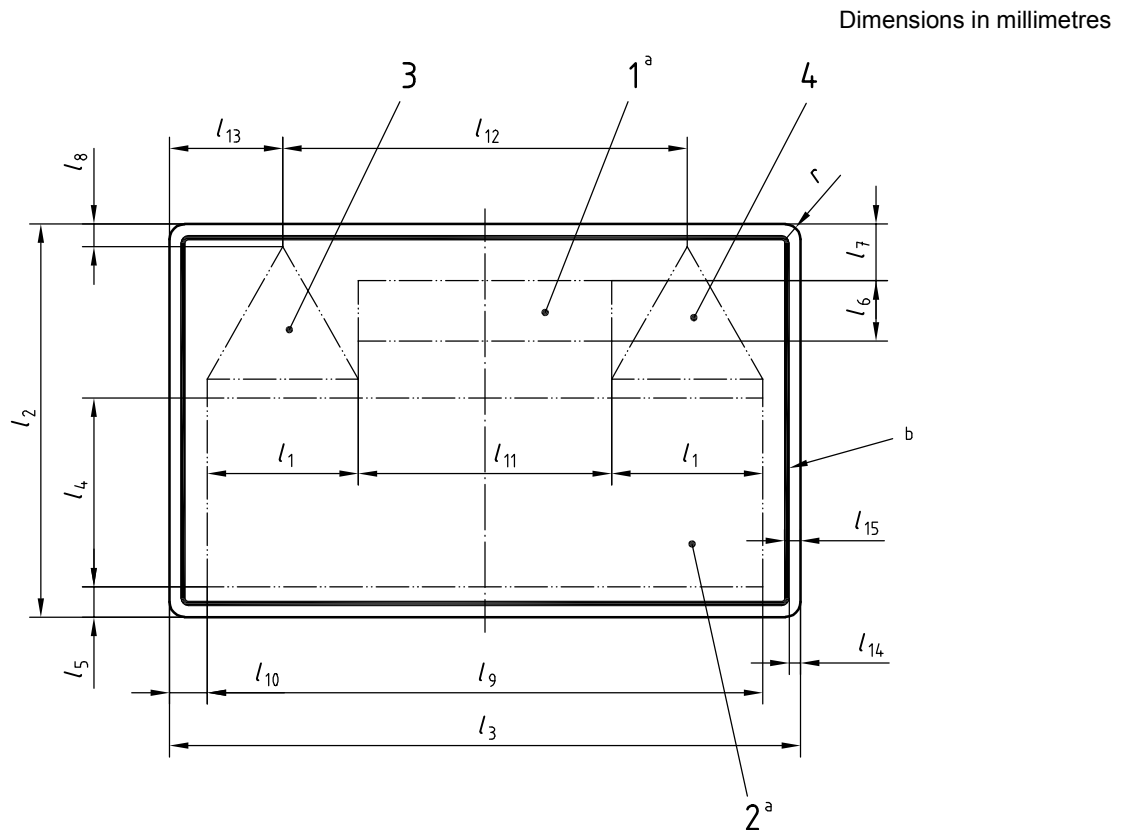

Figure B.2 — Caution: residual risk



The lettering size selected should make full use of areas 1 and 2. Warning sign, Form B, shall have the dimensions given in the following table:

$l_2 \times l_3$	l_4	l_5	l_6	l_7	l_8	l_9	l_{10}	l_{11}	l_{12}	l_{13}	l_{14}	l_{15}	l_1	r
40 × 64	17	4	5	8	3	54	5	22	38	13	0,9	1,6	16	1,6
52 × 84	25	4	8	8	3	74	5	34	54	15	0,9	1,6	20	1,6

Key

- 1 area 1
- 2 area 2
- 3 warning sign (see Figure B.1)
- 4 warning sign (see ISO 3864-2:2004, Figure A.5)
- a Text according to Clause B.2, in black, or same text in another language (see Annex K).
- b Border, black.

Figure B.3 — Configuration of warning sign — Form B

B.4 Warning sign — Form C

A warning sign independent of any text may be considered for the machine (see Figure B.4). Nevertheless, the written warning according to Figure B.2 shall always be incorporated in the instructions (see Clause 7).

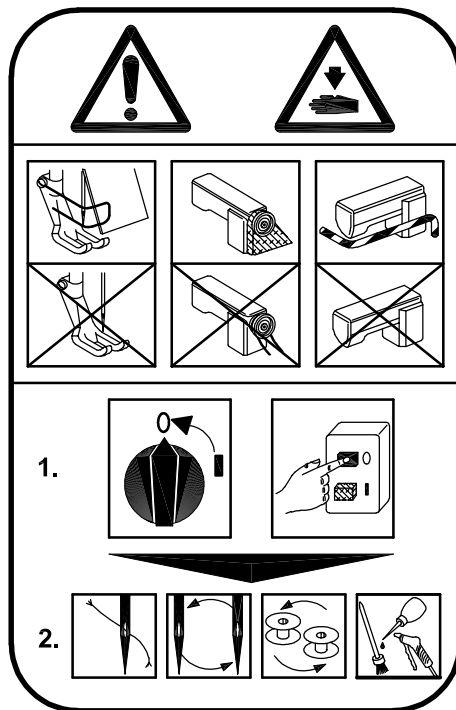

Figure B.4 — Example of warning sign — Form C

Annex C (normative)

Noise test code

C.1 Scope

This noise test code specifies all the information necessary for carrying out efficiently and under standardized conditions the determination, reporting, declaration and verification of the noise emission characteristics of sewing machines, units and systems.

Noise emission characteristics include emission sound pressure levels at workstations and the sound power level. The determination of these quantities is necessary for:

- manufacturers for declaring the noise emitted,
- comparing the noise emitted by machines in the family concerned,
- purposes of noise control at the source at the design stage,
- users, as a tool for planning building acoustics and organizational measures, and for evaluating the noise exposure of operators in workshops where such machines are used.

The use of this noise test code ensures reproducibility of the determination of the noise emission characteristics within specified limits determined by the Grade of accuracy of the basic noise measurement method used. Noise measurement methods allowed by this International Standard are Grade 2 (engineering) and Grade 3 (survey) methods.

For the majority of the sewing units and systems covered by this International Standard (machines covered by C.6.2), a simple and practical standard operating condition is defined to measure noise emission. For units and systems for which no standard operating condition can be defined (machines covered by C.6.3), practice-oriented and reproducible operating conditions for noise measurement are left to the choice of the user.

In addition, operating parameters and other key factors which, according to experience, have an effect on noise emission are listed as examples without, however, having claim to completeness.

C.2 General

C.2.1 Object to be measured

The object to be measured is the sewing unit or system with all functionally arranged components required for the application and function of the machine, including additional devices and safety devices as stated by the manufacturer in the instructions.

C.2.2 Methods for determining emission sound pressure levels

Methods for the determination of emission sound pressure levels at work stations and other specified positions are given in the following International Standards.

- ISO 11200 gives guidelines for the use of basic standards for the determination of emission sound pressure levels at the machinery work station.

ISO 10821:2005(E)

- ISO 11201 gives an engineering method for measuring emission sound pressure levels at the machinery work station.
- ISO 11202 gives a survey method for measuring emission sound pressure levels at the machinery work station.
- ISO 11203 gives an alternative method for determining the emission sound pressure levels at the machinery work station from the sound power level.
- ISO 11204 gives a method for measuring emission sound pressure levels at the machinery work station by using environmental corrections.

C.2.3 Methods for determining sound power levels

Methods for the determination of sound power levels are given in the following International Standards.

- ISO 3740 gives guidance for the choice of the method to be used for determining the sound power levels of machinery.
- ISO 3741 to ISO 3747 gives methods for determining machinery sound power levels from sound pressure measurements.
- ISO 9614-1 and ISO 9614-2 give methods for determining the sound power levels of machinery from sound intensity measurements.

Statistical methods for determining and verifying stated noise emission values are given in the following International Standards.

- ISO 7574-1 to ISO 7574-4 and ISO 4871.

NOTE Essential common terms for the application of the basic procedures are defined in the above mentioned International Standards (see Clause 3). Terms related to sound intensity methods according to ISO 9614-1 and ISO 9614-2 include accuracy Grade, sound pressure level, sound power level, sound intensity level, noise spectrum and measurement surface. Other essential terms for the application of the International Standards on acoustics ISO 11200 to ISO 11204 are A-weighted equivalent continuous sound pressure level, background noise correction K_{1A} , environmental indicator K_{2A} , local environmental correction K_{3A} , microphone position, impulsive noise and emission sound pressure level at the work station. Essential terms for the application of the engineering or survey methods according to ISO 3744 and ISO 3746 are: free field conditions over a reflecting plane, reference box, measurement distance, test surface area level, environmental correction, surface sound pressure level. Essential terms for the application of the reverberation method according to ISO 3741, ISO 3743 and ISO 3747 are: reverberation field, reverberation time, direct method and comparison method. Essential terms for the application of the sound intensity method according to ISO 9614-1 and ISO 9614-2 are: discrete points, intensity probe and scanning method.

C.2.4 Measuring method and equipment

For noise measurements according to this International Standard, the user has the possibility of applying the basic method that comes closest to the prevalent environmental conditions, choosing among the methods specified in ISO 11201 to ISO 11204, ISO 3741 to ISO 3747, ISO 9614-1 or ISO 9614-2.

Requirements for measuring equipment, data on the accuracy of the method and the uncertainty of the measurement results are to be found in ISO 3740 to ISO 3747, ISO 11200 to ISO 11204, ISO 9614-1 or ISO 9614-2.

C.3 Determination of A-weighted emission sound pressure level at operator position

C.3.1 Basic standards

The determination of the A-weighted emission sound pressure level at the operator position shall be carried out using one of the following basic standards:

- ISO 11201 (Grade 2),
- ISO 11202 (Grade 3), or
- ISO 11204 (Grade 2 or Grade 3).

Whenever practical, a method with Grade 2 of accuracy shall be used. Reasons for choosing a Grade 3 method shall be recorded and reported. Whenever the sound power level is available, ISO 11204 is the preferred method.

NOTE ISO 11200 describes the basic standards and gives guidance to the choice of the one best suited to the practical situation encountered.

C.3.2 Measurement position

The measurement position is the position of the operator's ear. It is defined as follows.

The microphone shall be located at a point defined in a machine-related X, Y, Z co-ordinates system.

The origin of the co-ordinates system lies in the sewing plane at the needle penetrating point and, on two and multiple needle machines, in the centre. On machines with a movable needle bar guiding frame, the mean position of the frame shall be chosen. On blindstitch machines, the centre between the penetrating and leaving points of the needle shall be chosen.

The Z-axis is perpendicular to the sewing plane, pointing towards the area from which the penetration of the needle occurs. See Figures C.1 and C.2.

The X- and Y-axes are in the sewing plane with the X-axis pointing against the feeding direction. See Figures C.1 and C.2.

The microphone shall be positioned at this measurement point and directed towards the origin of the co-ordinates.

If the measurement point actually chosen differs from the basic measurement point defined above, the microphone position used and the reasons for this deviation shall be recorded and reported.

Measurements shall be carried out with the operator present. The microphone shall be head-mounted. Specifications given in the basic standard used regarding the position of a seated operator and the mounting of the microphone shall be followed. The precise position of the operator with respect to the machine and the microphone arrangement shall be recorded and reported.

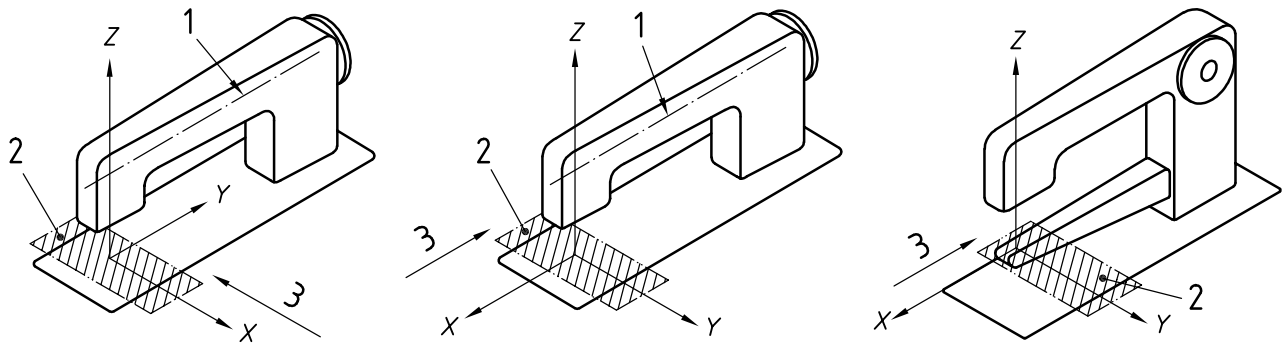

a) Flatbed sewing machine (feeding direction perpendicular to sewing machine axis) b) Flatbed sewing machine (feeding direction parallel to sewing machine axis) c) Feed-on-the-arm sewing machine

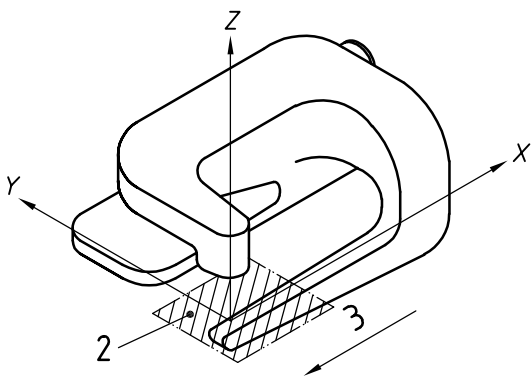

d) Feed-of-the-arm sewing machine

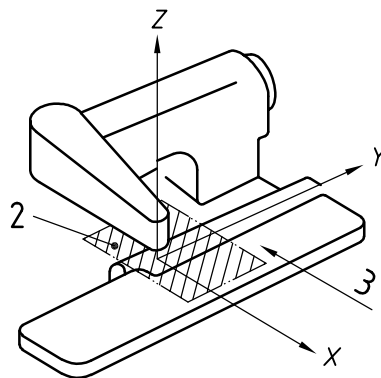

e) Blindstitch sewing machine

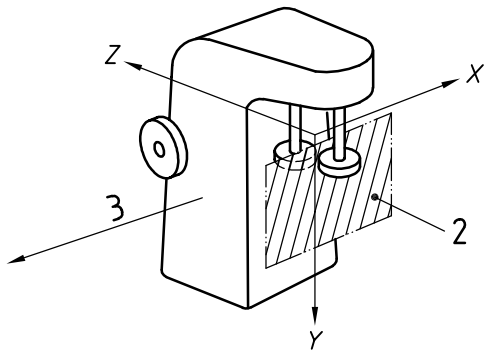

f) Cup feed sewing machine

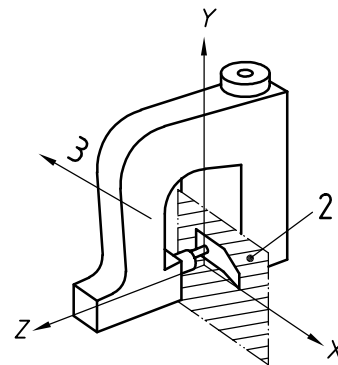

g) Bag-closing sewing machine

Key

- 1 sewing machine axis
- 2 sewing plane
- 3 feeding direction

Figure C.1 — Arrangement of co-ordinates system for different types of machines

The workstation is defined as the point with the following co-ordinates:

$X = 400 \text{ mm}$, $Y = 0 \text{ mm}$, $Z = 300 \text{ mm}$ (see Figure C.2).

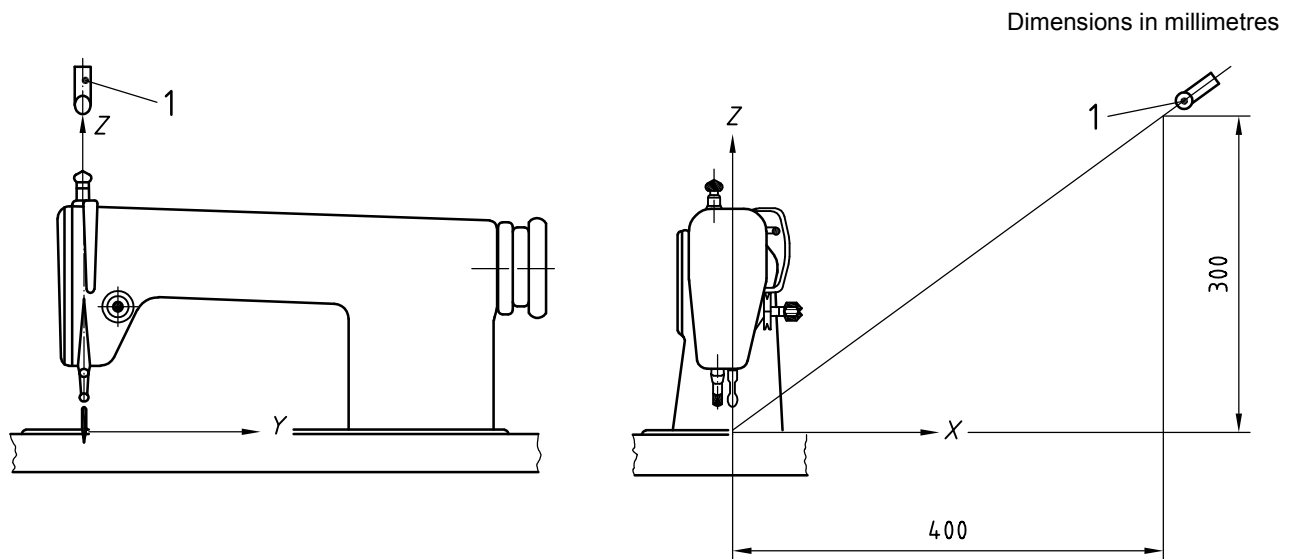

Key

1 microphone (Mp)

Figure C.2 — Measurement point (Mp)

C.4 Determination of A-weighted sound power level

C.4.1 Basic standards

The determination of the A-weighted sound power level shall be carried out using one of the following basic standards:

- ISO 3741 (Grade 1),
- ISO 3743-1 (Grade 2),
- ISO 3744 (Grade 2),
- ISO 3745 (Grade 1),
- ISO 3746 (Grade 3),
- ISO 3747 (Grade 2 or Grade 3),
- ISO 9614-1 (Grade 1, 2 or 3),
- ISO 9614-2 (Grade 2 or 3).

The preferred method is ISO 3744.

Whenever practical, a method of Grade 2 of accuracy shall be used. The reasons for choosing a Grade 3 method shall be recorded and reported.

C.4.2 Specific requirements when using ISO 3744, ISO 3746 or ISO 9614

When ISO 3744, ISO 3746 or ISO 9614 is used, the measurement surface shall be a parallelepiped. The measurement distance shall be more than 0,5 m. The preferred measurement distance is 1 m.

The reference box is shown in Figure C.3. In the horizontal plane, the reference box is formed by the greatest length and width L_1 and L_2 of the machine (sewing unit or system without stand or table top). The reference box height L_3 is defined by the machine height. For height-adjustable machines, L_3 shall be that corresponding to the majority of applications; the value chosen for the test shall be recorded and reported. The dimensions of the reference box are independent of the dimensions of the table top.

C.4.3 Setting up the machine

The reference plane for setting up the sewing unit and system with its stand is the measuring lab floor.

The machine shall be set up such that it is "structure-borne noise isolated".

C.4.4 Reference box, measurement surface, distance and points

C.4.4.1 Instructions when measuring sound power

When applying ISO 3744 or ISO 3746 (sound power using sound pressure method), or ISO 9614-1 or ISO 9614-2 (sound power using intensity method) the reference box, the shape of the measurement surface, the measurement distance between this surface and the reference box, and the measurement points on the measurement surface are all defined.

C.4.4.2 Instructions for the use of the reverberation method

When using the reverberation method, the arrangement of the microphones shall be defined according to ISO 3741, ISO 3743-1 or ISO 3747. The machinery to be investigated shall be set up in the test lab so that the main shafts are positioned eccentrically, and not parallel to the axes of the test lab.

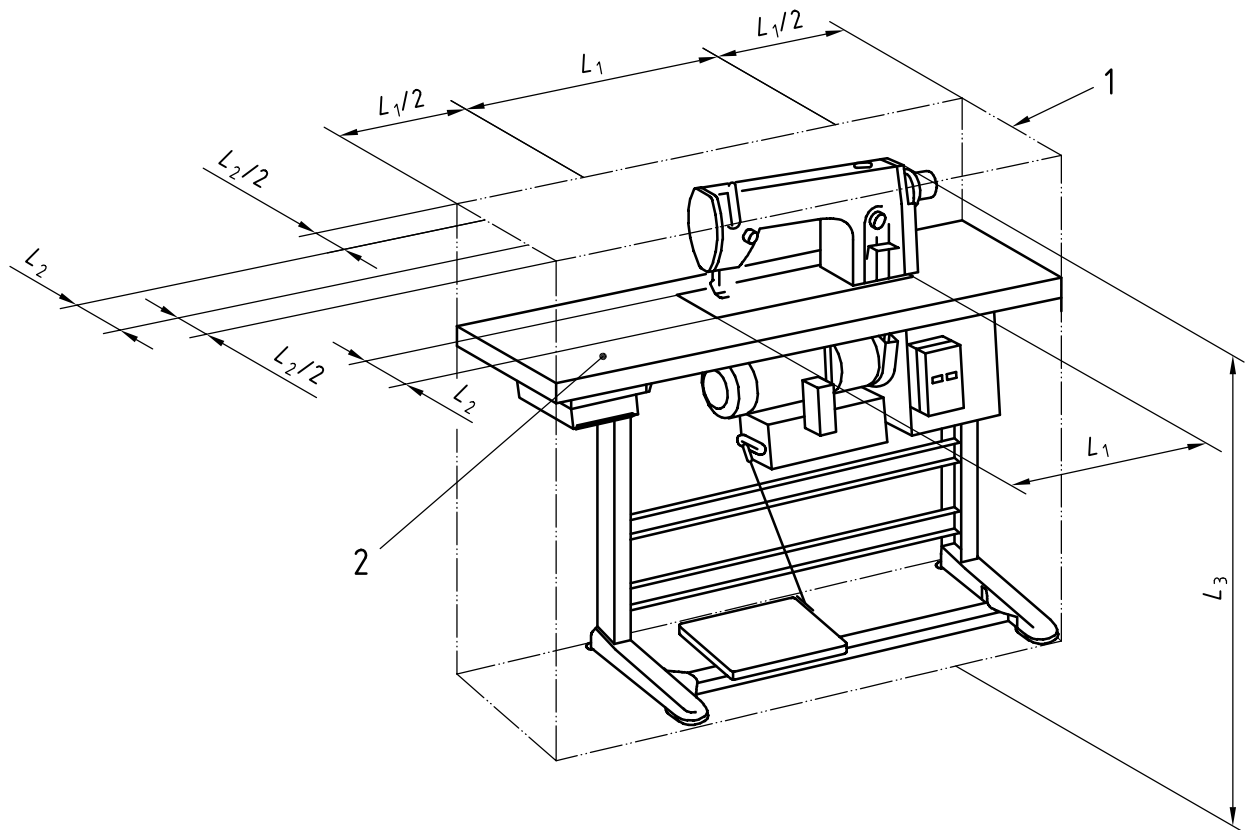
**Key**

- L_1 dimension of sewing head
- L_2 dimension of sewing head
- L_3 height of sewing unit
- 1 reference box
- 2 table top

Figure C.3 — Reference box**C.5 Mounting conditions**

The machine shall be mounted as indicated by the manufacturer in the instructions manual. In particular, if elastic mounts are recommended by the manufacturer, these shall be implemented. The technical and dimensional characteristics of these mounts shall be recorded.

C.6 Operating conditions**C.6.1 Common requirements**

Since the noise emission of machines depends considerably on the current operating condition and since various operating parameters can be set within a wide range, it is important that the operating conditions during noise measurement be defined in a practice-oriented but precise way.

Sewing machine needles and sewing threads are not part of the object to be measured, particularly, because — as shown by experience — these elements have no noticeable influence on the noise emission of machines with needles up to approximately 1,8 mm needle shank diameter. However, sewing material shall be used.

After warming up the sewing machine, measurements shall be taken at an operating temperature as constant as possible.

If a work cycle is specified in the instructions of the manufacturer, it shall be followed.

NOTE The main factors influencing the noise emission of sewing machines are stitch number, stitch length, sewing material, presser foot pressure, bottom and top feed stroke, knife stroke on trimming devices, gear drives, timing belt and V-belt drives, non-uniform transmission drives (such as cam gear drive and linkages), mechanical positioning devices, pneumatic adjusting devices and the mounting of the synchronizer.

C.6.2 Standard operating condition (CA machines)

C.6.2.1 General

Noise emission from sewing units or systems shall be measured in a fixed operating condition, i.e. at a constant speed. With the sewing unit or system in this condition, a stationary sound pressure level can be assumed. The measuring period consequently starts after reaching the constant condition and ends prior to leaving the constant condition.

Stationary sound radiation is achieved after a relatively short transient time. The time after which the noise emission becomes stationary can easily be determined by noise level measurements.

During noise measurement, all drives and devices shall be in operation as necessary for the application and function of the sewing unit or system according to the operating instructions of the manufacturer. The operation parameters to be set, including the sewing material to be used, are specified below.

If the various drives or devices exclude themselves from being set into operation simultaneously even though essential with regard to noise emission, it is necessary to take separate noise measurements for the various operating conditions that basically differ one from the other.

When the measurement results for operating conditions that exclude themselves one from the other are different, noise emission values and the pertinent data on the operating conditions may be determined, recorded and reported for all operating conditions. However, the operating condition yielding the highest noise emission and the corresponding noise emission values shall at least be reported.

When the operating conditions have been clearly defined to correspond to the standard operating condition according to this International Standard, reference to ISO 10821 is sufficient.

On machines with manual guiding of the sewing material, the standard operating condition includes the requirements of C.6.2.2. For machines where the sewing material is not guided manually or for which the standard operating condition is not applicable, the specifications of C.6.3 relating to non-standard operating conditions shall be followed.

C.6.2.2 Additional requirements for machines where the sewing material is guided manually

C.6.2.2.1 General

Manual guiding of the sewing material includes direct and indirect guiding.

NOTE To guide the sewing material means to determine the direction of the sewing material feed.

In general, the standard operating condition applies to machines covered by ISO 7115. For automated units and sewing units, the non-standard operating condition of C.6.3 applies.

For the standard operating condition and according to experience, noise emission comes close to that during actual sewing, without exceeding it.

In practice, the sewing process on machines with manually guided sewing material consists of short sewing cycles and interim breaks in which the operator repositions the sewing material, grasps again for further

guiding, and reaches for, or stacks workpieces. During sewing, the operator shall control the speed according to his/her individual method.

In general, the sewing process is performed inconstantly and depends on the actual sewing operation. Thus, the mode of machine operation varies, with short but different sewing and break intervals. Even though only for short periods, the machine will run up to the maximum possible speed for the given application.

Measurement of noise emission requires a constant operating condition (standard operating condition) which is independent of the actual sewing operation and of the individual operating mode. The standard operating condition shall be that which comes closest to the actual operating condition.

C.6.2.2.2 Machine settings

In order that the standard operating condition conform to the preceding requirement, the following machine settings shall be used.

- a) Setting of the operating speed (stitches per minute) which is specified by the manufacturer for all of the possible operating parameters (i.e. stitch length, stitch bight, presser foot pressure, upper feed stroke, etc.) for the majority of the applications;
- b) Setting of 80 ± 5 % of the maximum admissible settings as specified by the manufacturer:
 - setting of stitch length and all adjustable feed mechanisms;
 - setting of strokes at all adjustable feed mechanisms and additional devices (cutting devices), and on alternating upper feed mechanisms, equal stroke settings for both presser feet, provided these are adjustable in relation to one another;
 - relative motion between feed elements at differential feed mechanisms provided they are adjustable in relation to each other;
 - stitch bights and total stitch bights, provided they are adjustable in relation to each other.
- c) Setting of the presser foot force that is optimum for the function of the machine (this calls for setting the minimum presser foot force that allows constant feed of the sewing material).
- d) Setting of the feeding direction that is mostly required by the application.

C.6.2.2.3 Sewing material

The sewing material to be used shall be a woven fabric with a density of 250 g/m^2 , with the material width of a maximum of 100 mm, formed as an endless tape.

Depending on the maximum admissible needle shank diameter the number of sewing material plies shall be as follows:

- a) two plies at a needle shank diameter up to and including 0,9 mm (metric size designation Nm 90, according to ISO 8239);
- b) three plies at a needle shank diameter above 0,9 mm up to and including 1,3 mm (above Nm 90 to Nm 130, according to ISO 8239);
- c) four plies at a needle shank diameter above 1,3 mm up to and including 1,8 mm (above Nm 130 to Nm 180, according to ISO 8239);
- d) if the needle shank diameter exceeds 1,8 mm of kind of sewing material and the number of plies shall be determined, recorded and reported with an indication of the density of the sewing material. This shall also be done if, due to the application or agreement, another sewing material is used.

C.6.2.2.4 Additional devices

Additional devices operating synchronously to the speed during sewing shall be in operating mode.

In addition, continuously operating cutting devices separately driven during sewing shall be in operating mode.

C.6.2.2.5 Measurement duration

The duration of each measurement at a microphone position shall be in accordance with the basic standards used.

If several measurements are required, for example, repetition of measurement or when the sound pressure level has to be determined successively at various measurement points or if measurements have to be made successively at various narrow-band sources, a standstill time shall follow each measurement action. The minimum standstill time shall be 5 s.

C.6.3 Non-standard operating condition (CB machines)

C.6.3.1 General

If it is not possible or impractical to define a standard operating condition in accordance with C.6.2, then the operating conditions under which the measurements are taken may be chosen by the user to fulfil the following requirements. The conditions retained shall be recorded and reported in detail.

In general, CB machines with automatic workpiece guiding, including machines that automatically perform a sewing program, stitch pattern or sequence of stitches (including additional functions required by the application), prior or subsequent to, or during, the actual sewing, according to a controlled machine cycle.

In most cases, these machines include devices for controlling the workpiece feed according to the amount and direction, or needle movement, or both. In particular, they are sewing units and systems such as short seamers, bar tackers, buttonhole sewers and button sewers. Also included are embroidery machines, provided they are comparable in function with the other machines just mentioned.

In contrast to the machines according to C.6.2, most of these machines operate such that during the sewing process the workpiece is moved or guided during standstill without manual help. The feeding movement of the workpiece (relative movement between workpiece and sewing needle) is performed either by a control device belonging to the machine or by an external device (e.g. robots or similar handling devices) which, however, are synchronized with the controlled machine cycle. On such machines, the loading and unloading of workpieces and other parts, the positioning of workpieces (e.g. in positioning devices) and the starting of the sewing process, either manually or by handling devices that belong to the machine or are external, is automatically performed.

When describing such a non-standard operating condition, it is useful to refer to this International Standard and, in addition, to state the divergent or supplementary operating conditions. In other cases, the operating conditions shall be recorded and reported in detail.

C.6.3.2 Operating conditions

C.6.3.2.1 General

For machines with an automatic workpiece guiding mostly operated in cycles, no standard operating condition can normally be defined, because of the following:

- a) speeds that vary during the sewing process and which are normally determined by the controlled machine cycle (e.g. reduced speeds at the start and at the end of the sewing operation for latch tacking the thread chain, for trimming the upper and lower threads, for cutting the buttonhole during buttonhole sewing);

- b) Additional devices which, for example, are in use only prior or subsequent to the actual sewing (e.g. as separators, stackers or feed-in devices for parts to be attached), or which, in the case of overlapping operations, are only part time in parallel to the sewing operation (e.g. folding devices on pocket setters).

Therefore, operating conditions have to be chosen which correspond to both the actual conditions and the majority of the applications. In the case of sewing systems, this covers all necessary application-related machines, auxiliary devices and, if appropriate, handling devices. If the machines are not operated in cycles or if the sewing cycle (running time and break time) includes varying break durations, a characteristic sewing process can be defined as the operating condition for the noise measurement, to be repeated, if necessary, according to the required measurement duration.

C.6.3.2.2 Machine settings

For the non-standard operating conditions, the following settings shall be made at the machine or machines.

Provided operating parameters can be adjusted and reasonably chosen, the setting conditions according to C.6.2 are applicable. If additional settings or those deviating from C.6.2 are required, such settings should be chosen in relation to the majority of the applications. If for these applications, the setting conditions are clearly defined in the manufacturer's instructions (operator's manual), recording and making reference to that document is sufficient; otherwise the operating conditions shall be described in detail.

For sewing units and systems, the number of possible settings can, of course, be very high. To restrict the extent of documentation in these cases, it is sufficient to record and report the description of the actual application by indicating the settings in place of describing the operation conditions.

If seam patterns (e.g. bar pattern, embroidery pattern with number of stitches, stitch length) are freely programmable, or stored in exchangeable CD ROMs, or freely selected, the production of the sewing pattern during noise measurement should include all possible feeding directions, stitch length and a number of stitches sufficient for the duration of measurement according to practice. The permissible sewing area should allow sewing to be carried out, at least in the most important areas (corners, centre), at an identical speed.

The sewing program used for the measurements shall be recorded and reported.

C.6.3.2.3 Sewing material

If possible, the sewing material shall be used in accordance with C.6.2; if not, the material sewn in the majority of the applications shall be used.

For sewing units and systems that normally require pre-cut pieces during sewing, any material present may be used for the operation during measurement.

If sewing material different from that according to C.6.2 is used, this shall be recorded and reported by indicating the density in grams per square metre.

C.6.3.2.4 Auxiliary devices

Auxiliary devices directly or indirectly operated on, or by, the machine shall be in operation during the measurement.

If basically different operating conditions are possible (see also C.6.2) because of the use of different auxiliary devices, depending on the application, such operating conditions shall be measured separately and, at least the highest noise emission values shall be recorded and reported.

This applies in particular to sewing systems, but the same procedure also applies to individual machines within a sewing system with respect to operation and standstill.

C.6.3.2.5 Measurement procedure

In general, machines with non-constant operation also generate non-constant sound pressure levels; special attention shall be paid to the impulsive noise (follow the basic standards used).

Since with the non-constant operation of a machine, the sound pressure level considerably varies not only within one sewing cycle (running time and break time), but also from cycle to cycle, the noise measurement should be taken over several cycles. At short cycles (< 1 min) at least three cycles shall be measured; at long cycles one cycle is sufficient. The ratio between running time and break time shall be considered. If the relation is > 9, the standstill portion can be neglected.

C.7 Information to be recorded

The information to be recorded is that required by the basic standard or standards used and by this annex.

C.8 Information to be reported

The information to be reported is that required by the basic standard or standards used and by this annex.

The test report shall contain precise data on the construction of the object measured. Indicating the machine type stated by the manufacturer is sufficient, provided the full description of the object measured is given.

When reporting, the identification of the noise measurements shall be done using the following code:

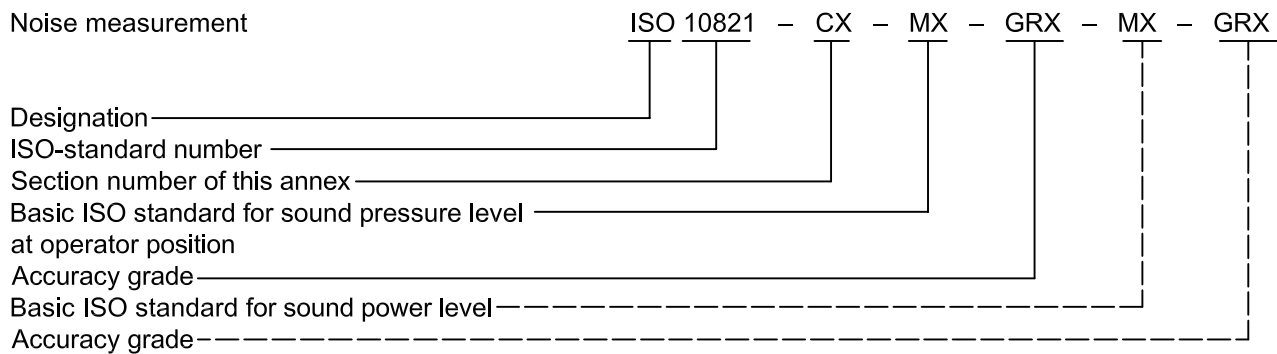

where

CX is either CA (see C.6.2) or CB (see C.6.3);

MX is the reference number of the basic standard used and GRX the corresponding grade of accuracy.

EXAMPLE "ISO 10821 – C.6.2 – ISO 11204 – GR 2 – ISO 9614-2 – GR 2" means that noise emission determination has been carried out according to this standard, with the standard operating condition specified in C.6.2, using ISO 11204 (which provided Grade 2 data) for determining the emission sound pressure level at the operator position and ISO 9614-2 (which provided Grade 2 data) for the determination of the sound power level.

C.9 Noise declaration

The noise emission value given shall be either the dual number declaration (the measured value and the associated uncertainty) or the single number declaration (the sum of the measured value and the associated uncertainty). It is recommended that the dual number declaration be chosen.

EXAMPLE $L_{pA} = 79,5 \text{ dB}; K_{pA} = 2,5 \text{ dB (uncertainty)}$ or $L_{pA} = 82 \text{ dB (includes uncertainty of } K_{pA} = 2,5 \text{ dB)}$.

The noise declaration shall give

- the A-weighted emission sound pressure level at the operator position where this exceeds 70 dB, or, where this level does not exceed 70 dB, this fact shall be indicated, and
- the A-weighted sound power level where the measured value of the A-weighted emission sound pressure level at the operator position exceeds 85 dB.

The designation code according to C.8 shall be used.

The noise declaration shall give details of the operating conditions used during noise emission measurement.

The noise declaration shall be made in such a manner that, in case of verification, declared values can be verified according to ISO 4871. In case of verification:

- mounting and operating conditions to be used shall be the same as those used for the initial determination of the declared values;
- a measurement method with the same grade of accuracy as that used for the initial determination of the declared values, shall be used.

NOTE 1 When a unit declaration is made by the manufacturer (i.e. declared values have been obtained on the particular machine for which the declaration is made), the uncertainty is that of the measurement method used. A maximal value of this uncertainty is indicated in the basic standard or standards used. A recommended value for the uncertainty K , for both the A-weighted emission sound pressure level at work station and the A-weighted sound power level, is 2,5 dB. A manufacturer can use a lower value of this uncertainty if he has technical evidence that such a lower value is correct.

NOTE 2 When the declaration is made by a manufacturer for a batch of machines, the total uncertainty of the determination is the combination of the uncertainty of the measurement method used (see NOTE 1) and of the production uncertainty (i.e. variation of noise emission from one machine to another in the same production). ISO 4871 gives a method for determining the production uncertainty and indicates how to combine the two components of the uncertainty in order to obtain the total uncertainty. It also suggests values of the total uncertainty that can be used by a manufacturer who lacks experience with noise emission determination and available noise emission data.

Additional noise emission quantities such as sound power levels in octave bands and impulsiveness may also be given in the noise declaration, provided the basic standard(s) used allow(s) such quantities to be determined. In this case, care shall be taken to avoid confusion between these additional noise emission data and the declared noise emission values.

C.9.1 General verification requirements

Verification of the noise data for sewing units or systems in this International Standard is based on the statistical procedures according to ISO 7574-2 for single machines and ISO 7574-4 for batches of machines.

For batches of machines, the verification shall comply with the random test measure and the following requirements:

- noise measurements according to this International Standard and the declaration by the manufacturer (see Annex I);
- a sample size of $n = 3$;
- a reference standard deviation, σ_M , according to ISO 7574-2 and ISO 7574-4, and the manufacturer's declaration for the specified machine batch.

For single machines, verification shall be made according to this International Standard and the manufacturer's declaration (see Annex I).

C.9.2 Declared value for noise emission for batches of machines

The method of determining the declared value, L_C , for noise emission for batches of machines for a specific acceptance probability selected by the manufacturer, and depending on the reference standard deviation as well as the actual total standard deviation, shall be in accordance with ISO 7574-4.

If the manufacturer accepts a risk of rejection of 5 % (i.e. with the desire for a probability of acceptance, P , of 95 %), the resulting equation is

$$L_C = \mu + 1,5\sigma_M, \sigma_M = \sigma_t, \mu = \frac{1}{N} \sum_{i=1}^N L_i$$

where

- L_C is the declared value for noise emission;
- μ is the mean value of the batch;
- σ_M is the specified reference standard deviation;
- σ_t is the actual total standard deviation;
- L_i is the measured values in the batch;
- N is the size of the batch.

If σ_t is unknown, σ_M can be estimated to 2,5 dB for a Grade 2 measurement method.

A verification is considered to have been successful if the declared value for noise emission L_C meets the following condition:

$$L_C \geq L + 0,564\sigma_M, \bar{L} = \frac{1}{n} \sum_{j=1}^n L_j$$

where

- σ_M is the specified reference standard deviation;
- \bar{L} is the arithmetic mean of the values in the sample;
- L_j are the values of the sample measured when verifying;
- n is the fixed sample size ($n = 3$).

C.9.3 Declared value for noise emission for single machines

The method of determining the declared noise emission value L_C for a single machine for a specific acceptance probability selected by the manufacturer, and depending on the reference standard deviation as well as the actual total standard deviation, shall be in accordance with ISO 7574-2.

If the probability of acceptance is 95 %, L_C shall be defined as follows:

$$L_c \geq L^* + K$$

where

L^* is the measured value for the individual machine (the level obtained by the manufacturer when using this Annex);

K is the value chosen to account for the random measurement errors occurring under reproducibility conditions (an appropriate value may be estimated to 2,5 dB for a Grade 2 measurement method).

A verification is considered to have been successful if L_c is not below the value obtained in the verification.

.....

Annex D (normative)

Needle breakage protection shield

The needle breakage protection shield shall be designed and fitted such as to prevent injuries, especially eye injuries, caused by the ejection of parts, e.g. splintered or broken sewing machine needles.

This requirement may be met by a sufficiently large, robust transparent shield in front of the needle and in view of the operator, which shall not hinder threading, changing needles and handling of workpieces.

Suitable constructions are the

- fixed needle breakage protection shield, of which an example is shown in Figure D.1, and
- movable needle breakage protection shield, which is coupled or interlocked with the sewing process (e.g. sewing machine drive).

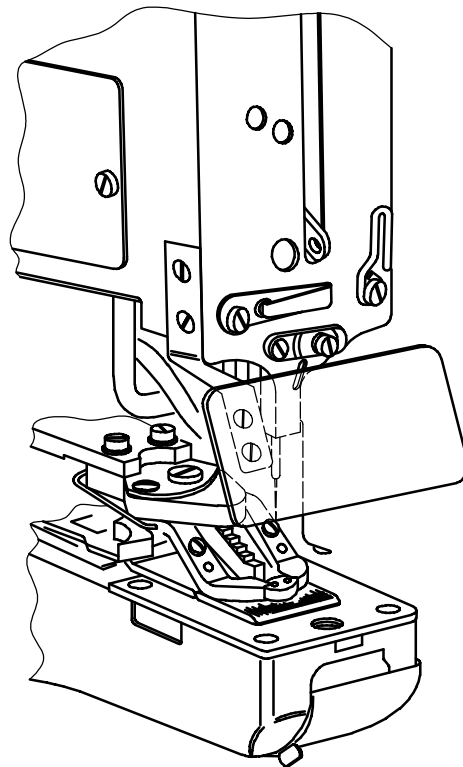

Figure D.1 — Fixed version — Example

Annex E (normative)

Belt guard at sewing machine drive (motor)

The following requirements are applicable to the belt guard at the sewing machine drive, which is normally mounted below the sewing machine table.

- The belt guard, Version A or B, shall be part of the sewing machine drive (with or without position device).
- If the sewing machine drive is fitted in a different manner to the industrial sewing unit, then further safety measures shall be taken into consideration.
- The belt guard shall have a belt dropping prevent device as shown in Figures E.1 and E.2, provided that it is used with tiltable sewing machines.
- The belt guard shall allow the operation of grooved pulleys, as specified in Annex F, in both directions of rotation.
- The belt dropping prevention device shall be efficient at the matching sizes of grooved pulleys according to Tables F.1 and F.2 of Annex F.
- The pulley shall be covered from all sides except for the openings for the running belt.

Dimensions in millimetres

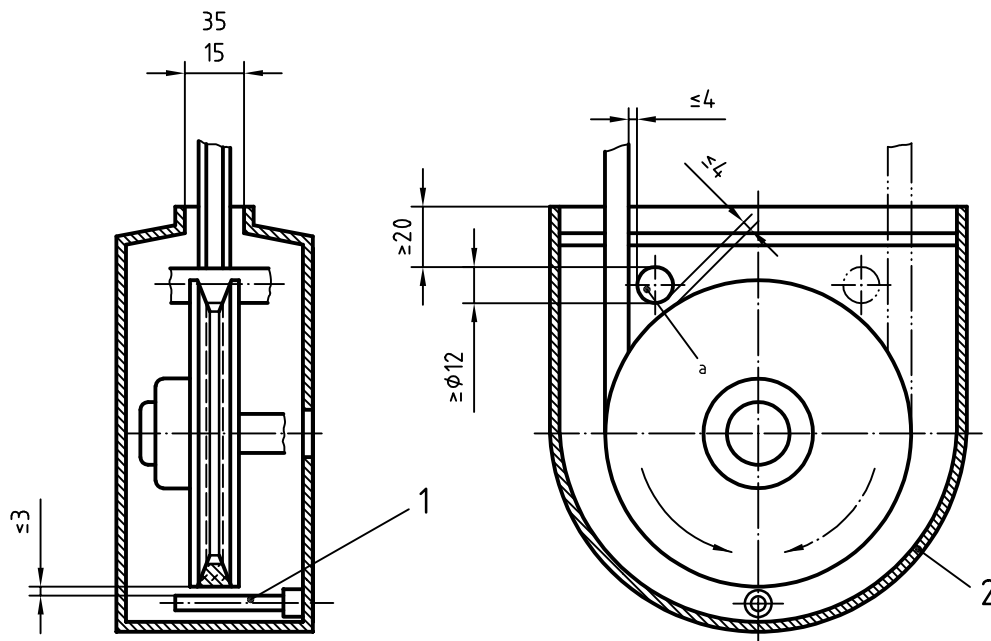

Key

- belt dropping prevent device (see detail, Figure E.2)
 - covering curve of inside of belt guard
- a Within this circle, the belt take-up point at the grooved pulley shall be secured.

Figure E.1 — Example of belt guard (motor)

Dimensions in millimetres

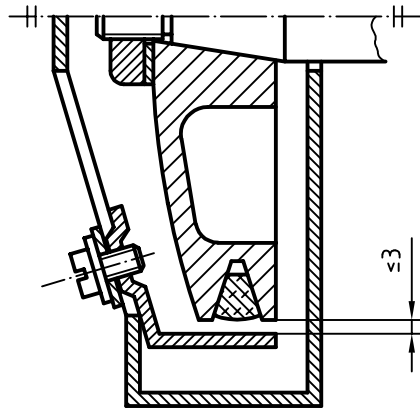

Figure E.2 — Detail showing belt dropping prevent device

Annex F (informative)

Safe fastening of belt pulley at drive shaft of clutch or positioning drives

F.1 General

F.1.1 Because of frequent motor actuation, a taper fit is recommended for safe fastening of the belt pulley at the drive shaft.

F.1.2 For construction of the conical shaft end with external metric ISO thread for fastening and pulling-off equipment (see F.1.3):

- the fit of Form A, B and C grooved pulleys according to Clause F.2. should be possible;
- the conical shaft end should have an external metric ISO thread for fastening and pulling-off equipments, Form B, grooved pulleys (see Figure F.4).

Dimensions in millimetres

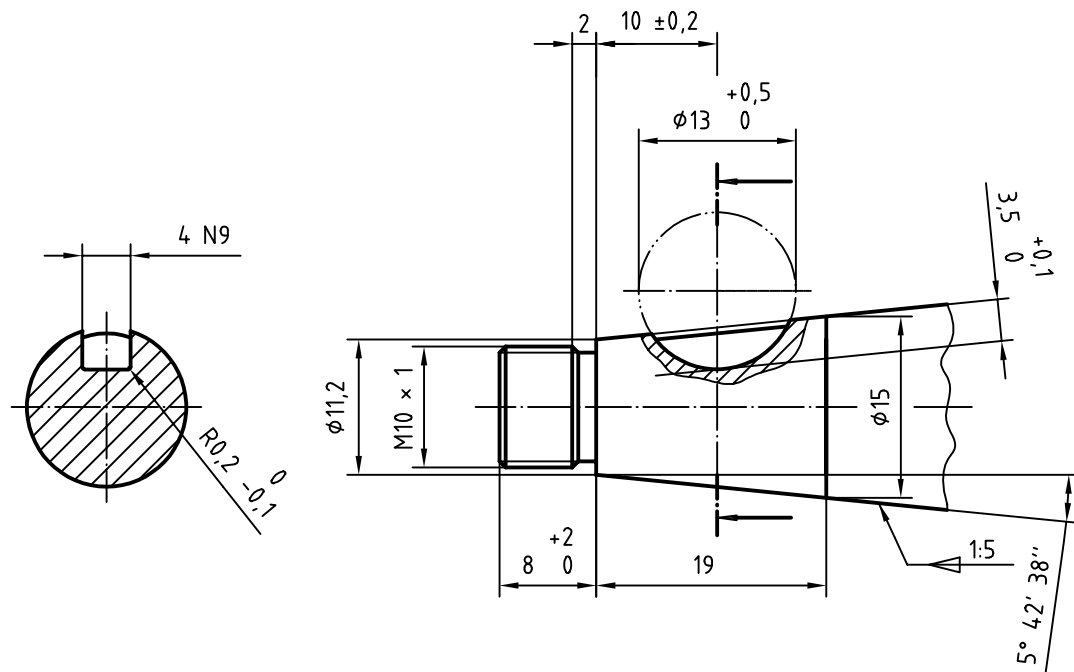
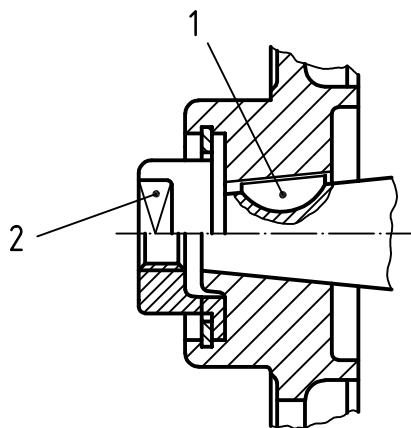

Figure F.1 — Taper fit

F.1.3 In respect of the construction of fastening and pulling-off equipment:

- Figure F.2 refers to grooved pulley Form B;
- a nut with a metric ISO thread M10 × 1 should be used (securing of the nut, as well as the rest of the Form and design of the pulling-off equipment, is at the option of the manufacturer).



Key

- 1 slice, 4 × 5
- 2 nut, M10 × 1

Figure F.2 — Pulling-off equipment

F.2 Grooved pulleys

F.2.1 Dimensions

Recommended grooved pulley dimensions are shown in Figures F.3, F.4 and F.5 for Forms A, B and C, respectively, while sizes are given in Table F.1 for Forms A and B, and Table F.2 for Form C.

Dimensions in millimetres,
surface roughness values in micrometres

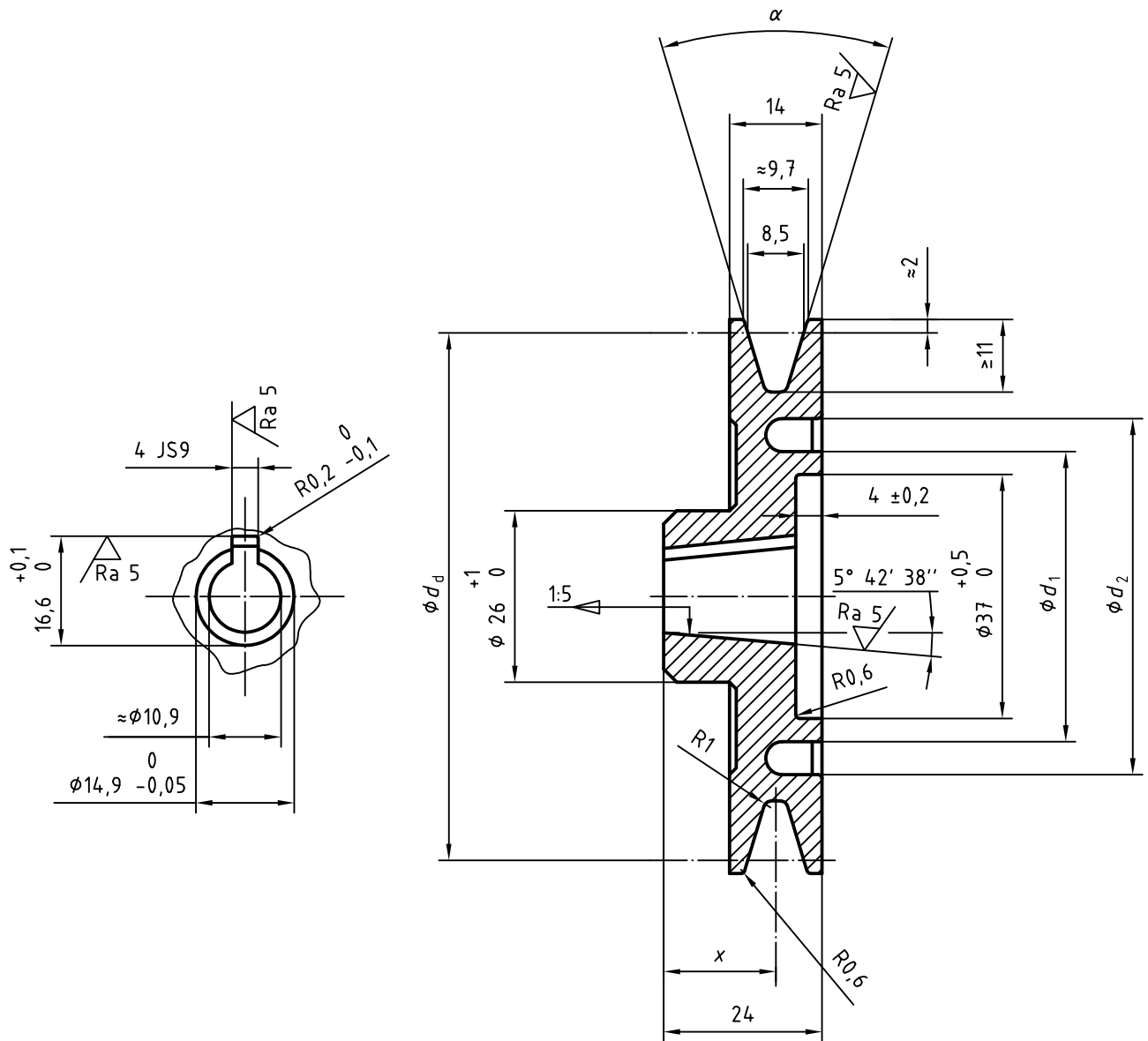

Figure F.3 — Form A grooved pulley

Dimensions in millimetres,
surface roughness values in micrometres

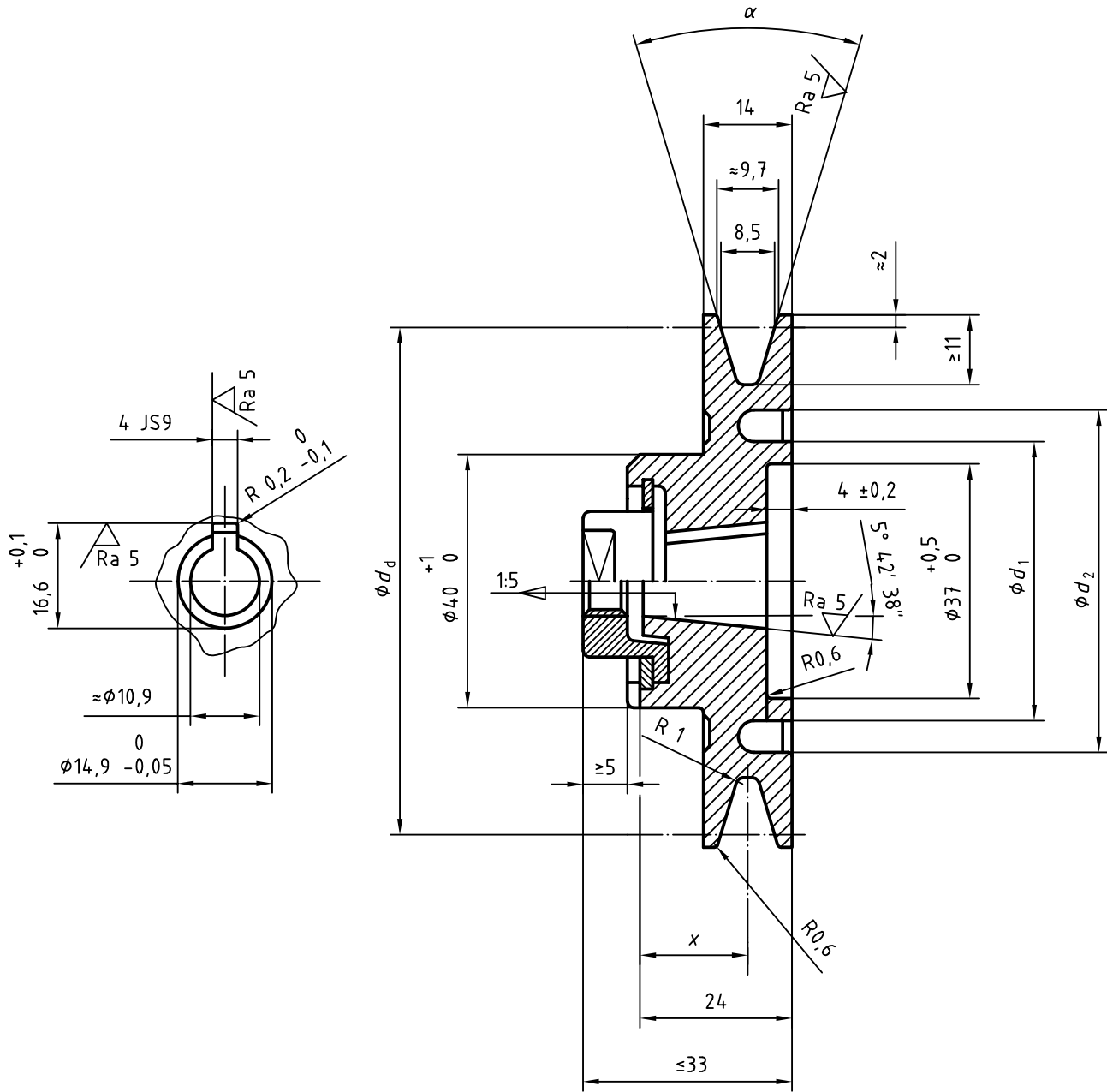

Figure F.4 — Form B grooved pulley

Dimensions in millimetres,
surface roughness values in micrometres

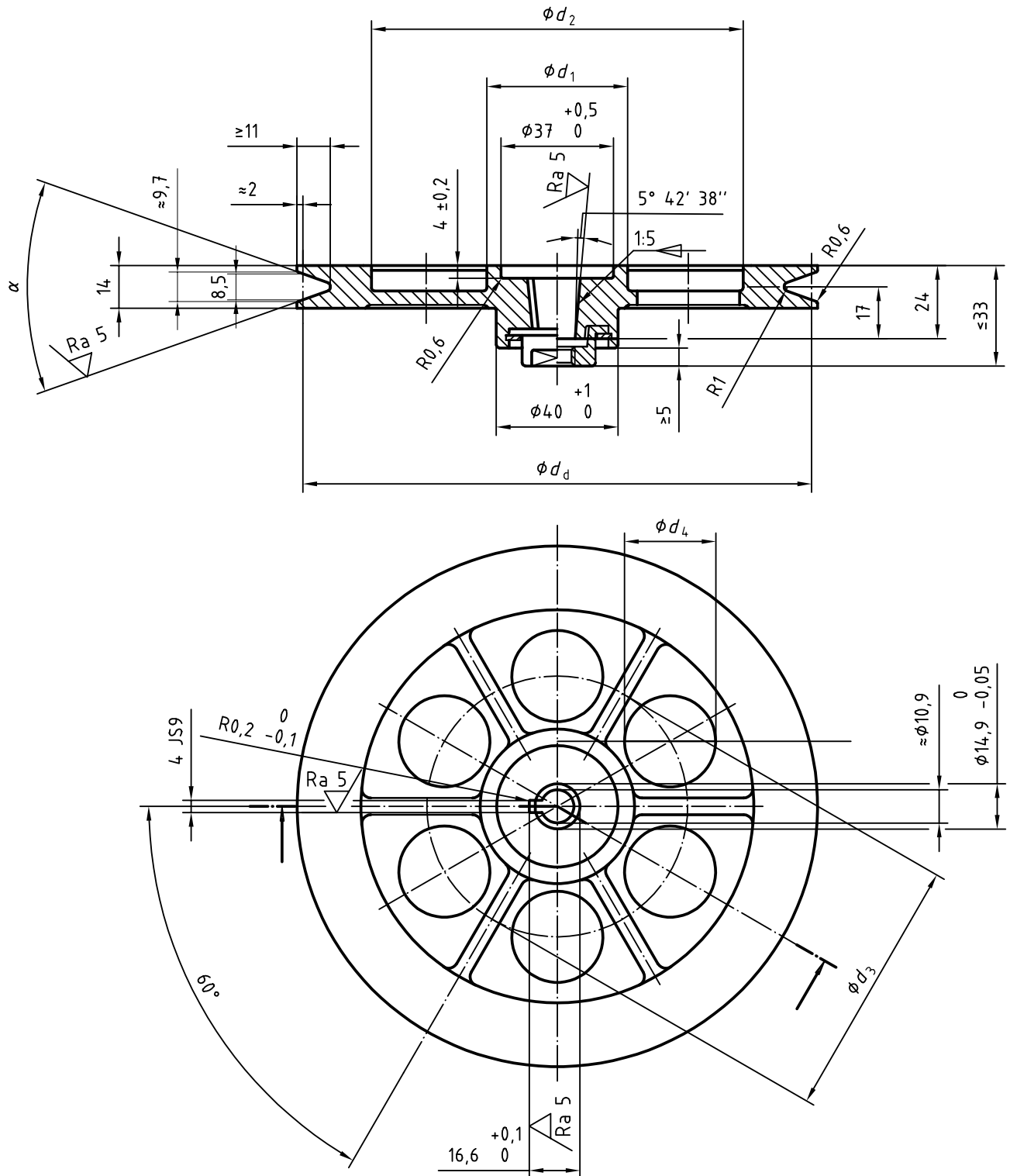

Figure F.5 — Form C grooved pulley

Table F.1 — Forms A and B grooved pulley sizes

Dimensions in millimetres

$d_{d\text{ nom}}$	d_d		α $\pm 0,5^\circ$	d_1	d_2	x
	min.	max.				
50	50,0	50,8	34°	—	—	16
58	58,0	58,9				
63	63,0	64				
67	67,0	68,1				
71	71,0	72,2				
75	75,0	76,2				
80	80,0	81,3				
85	85,0	86,4	38°	45	58	17
90	90,0	91,4			63	
95	95,0	96,5			68	
100	100,0	101,6			73	
106	106,0	107,7			79	
112	112,0	113,8			85	
118	118,0	119,9			91	
125	125,0	127			98	
132	132,0	134			105	
140	140,0	142,2			113	

Table F.2 — Form C grooved pulley sizes

Dimensions in millimetres

$d_{d\text{ nom}}$	d_d		α $\pm 0,5^\circ$	d_1	d_2	d_3	d_4
	min.	max.					
150	150,0	152,3	38°	45	118	82	30
160	160,0	162,5			128	87	34
170	170,0	172,6			138	92	38
180	180,0	182,7			148	100	42

F.2.2 Recommendations

General tolerances should be according to ISO 2768-m.

The nominal values of datum diameter d_d and the groove angle α should be in accordance with ISO 4183.

The grooved pulleys should be used with classical, as well as narrow V-belts, according to ISO 4183:1995, Table 3.

Grooved pulleys should have equipment for fastening and pulling off according to Figure F.2.

F.2.3 Designation

EXAMPLE 1 Designation of a belt guard version A with a maximum d_d equal to 180 mm:

Belt guard ISO 10821-A180

EXAMPLE 2 Designation of Form A grooved pulley, with a nominal diameter, d_d , of 80 mm and made of aluminium:

Pulley ISO 10821-A080-AL

Annex G (informative)

Safe mounting of adaptable positioner/synchronizer at sewing machine shaft

G.1 Recommendations

If a sewing machine table is part of the sewing unit or system, there should be an opening for the cable of the electrical supply of the positioner/synchronizer of at least 21 mm diameter.

The positioner/synchronizer is connected to the sewing machine shaft. The shafts should have the following limits and fits for the connection:

- on slow-running industrial sewing machines, a shaft diameter of 22,2 mm and a tolerance Class k8 in accordance with in ISO 286;
- on fast-running industrial sewing machines, a shaft diameter of 22,2 mm and a tolerance Class p6 in accordance with in ISO 286.

G.2 Details of construction

See Figure G.1.

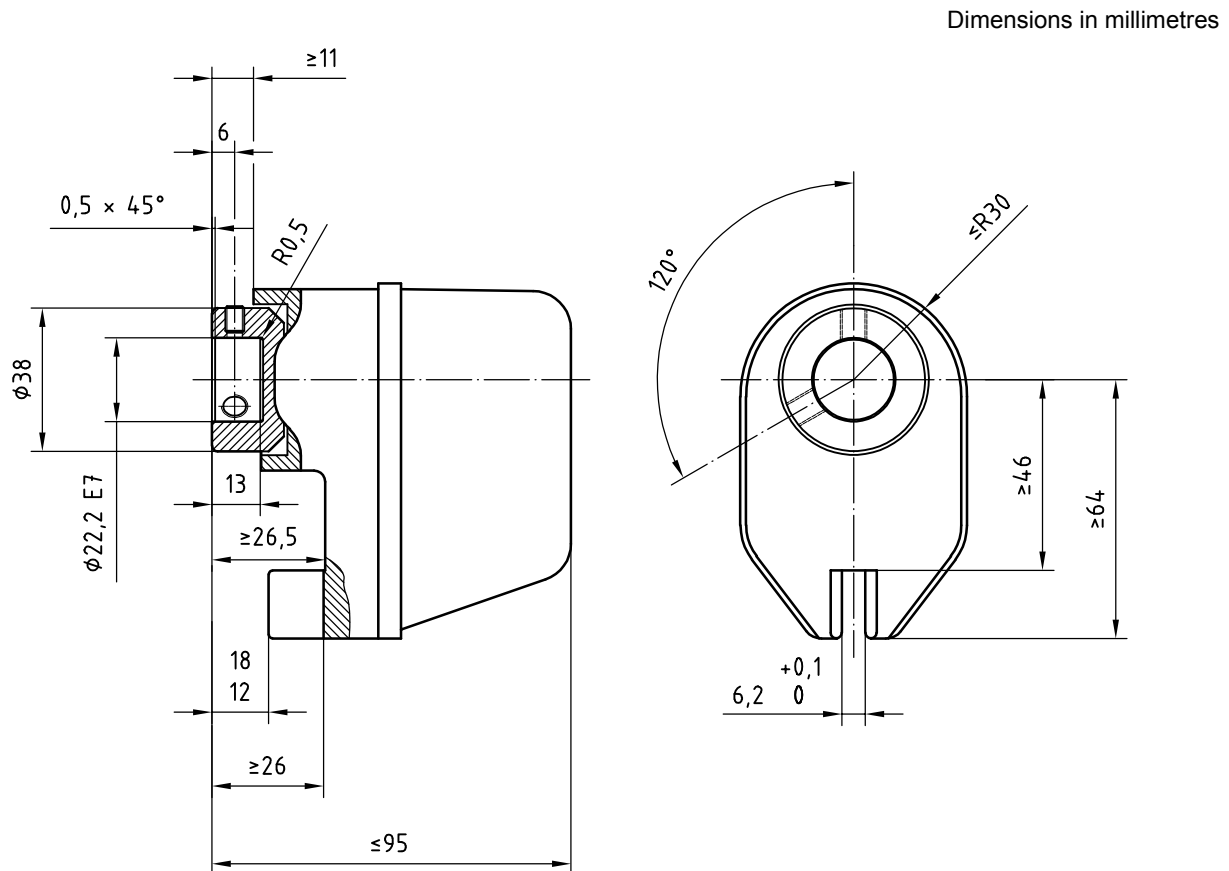

Figure G.1 — Adaptable positioner/synchronizer

Annex H (informative)

Safe mounting of sewing machine drives

H.1 Mounting of sewing machine drive

The motor base provided by the sewing machine drive manufacturer is used to mount the sewing machine motor. Examples are shown in Figure H.1. This base should be secured over three points. The size of the base is as shown in Figures H.2 and H.3. However, bases combining the borings of the base according to Figure H.2 and H.3 can also be used. Slots instead of holes can be made to ensure the alignment of the pulleys with either of the bases shown in Figures H.2 and H.3.

A strong, sturdy table or mounting board should be used to mount the sewing machine drives. This board can be made out of wood, which should be of a minimal thickness of 35 mm, or can be of metallic construction. Screwed inserts for the bases should be anchored into the table or mounting board if the strength and thickness of either is sufficient to ensure that the bolts hold fast [see Figure H.1 a)]. Otherwise, holes that totally penetrate the thickness should be provided for the mounting screws [see Figure H.1 b)].

Screws with a diameter of 8 mm should be used to secure the drive. The fastening should be performed such that no sharp edges protrude which might injure the operator. In the event of the screw heads protruding over the top edge of the table, rounded screw heads according to ISO 8678 are to be used. The examples a) and b) in Figure H.1 show the possibility of either fastening where the mounting board has a greater strength and thickness or where the board has a reduced strength.

Different ways of mounting the sewing machine drive should be agreed with the sewing machine drive manufacturer.

Dimensions in millimetres

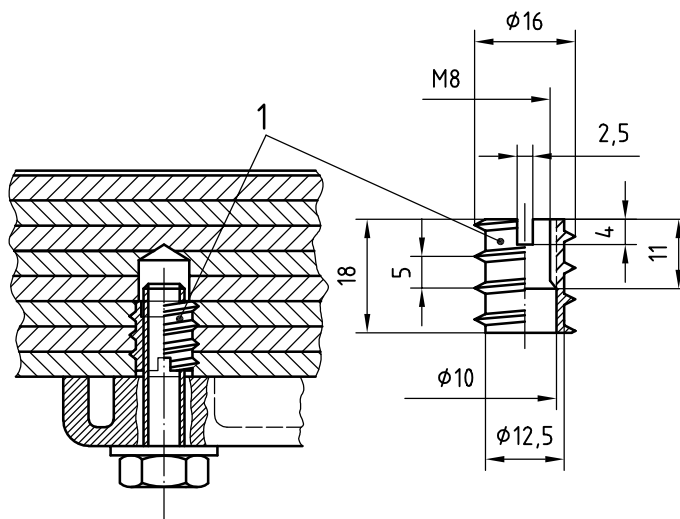

a) Mounting in multi-ply bonded table-top (plywood)

Figure H.1 — Examples for mounting

Dimensions in millimetres

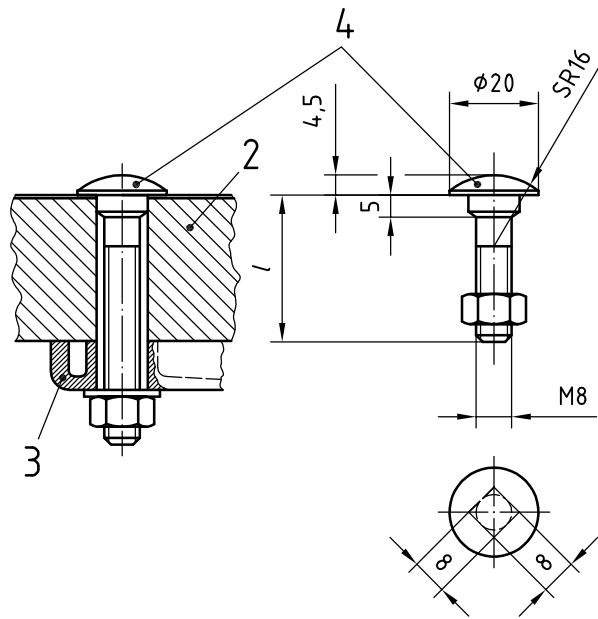

b) Mounting in table top with reduced level of resistance (particle board)

Key

- 1 screwed inserts
- 2 table
- 3 motor base
- 4 rounded screw heads according to ISO 8678

Figure H.1 — (continued)

Figures H.2, H.3 and H.4 show the envelopes in which the sewing machine drive should be mounted. This is to ensure that the function or mounting of other appropriate equipment (e.g. pneumatic equipment) is not hindered. The envelope encloses the motor together with its control box, belt guard and screws fastening the motor base to the table. Plugs and leads should not protrude more than 30 mm outside this envelope.

The motor should be capable of being swivelled along vertical axes at Point A (see Figure H.4) within the area of the envelope.

Dimensions in millimetres

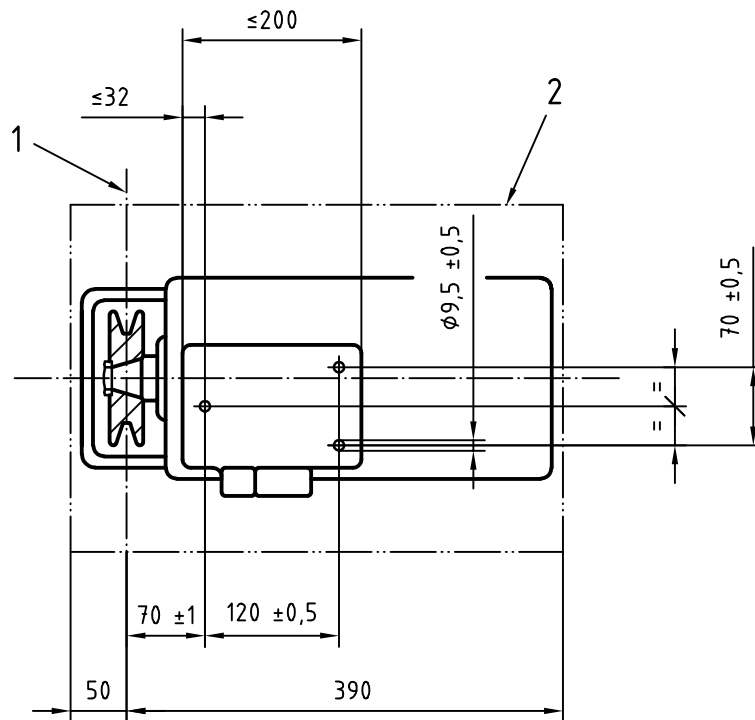

Key

- 1 centre of pulley
- 2 envelope

Figure H.2 — Base Form A and envelope

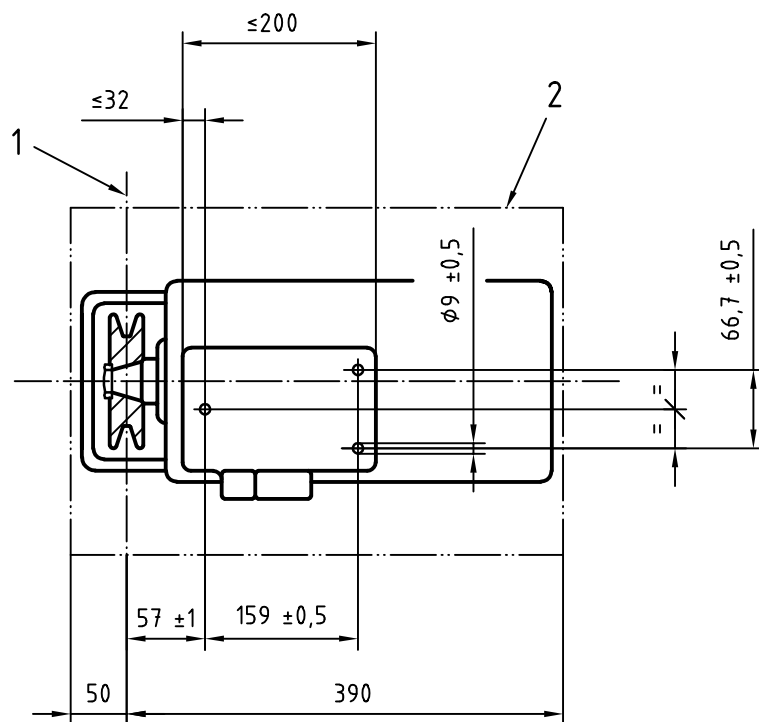

Key

- 1 centre of pulley
- 2 envelope

Figure H.3 — Base Form B and envelope

Dimensions in millimetres

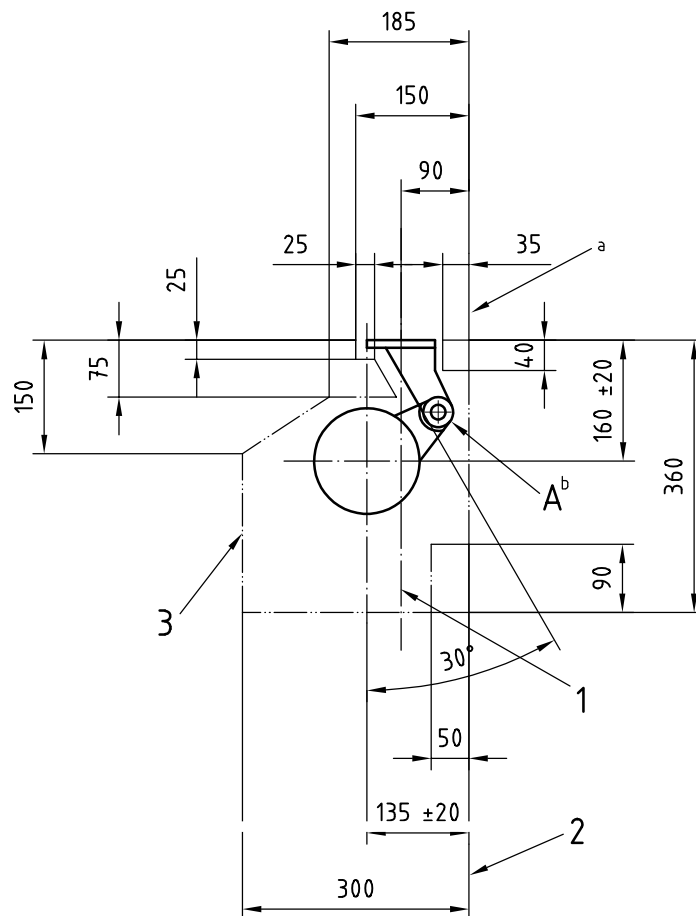

Figure H.4 — Envelope/side view — Forms A and B

H.2 Requirements for belt drive installation

The pulleys on the sewing machine drive and on the sewing machine shall be in exact alignment.

The belt tension shall be in accordance with the instructions laid down by the sewing machine drive manufacturer.

The pulley shall be secured by a belt guard in accordance with Annex E.

The attachment of the belt guard and the adjustment of the belt dropping prevent device should be carried out according to the sewing machine drive manufacturer's instructions.

Annex I (informative)

Noise declaration examples

Data on noise emission of sewing machines and units obtained using the measurement method according to Annex C are necessary to enable manufacturers to prepare the noise declaration given in the manufacturer's instructions. They may also be included in other technical documents describing the machine, such as specification sheets, offers and brochures, made available to potential buyers.

This International Standard covers the declaration and verification of noise emission values of machinery and equipment for single machines and batches of machines. It is left to the discretion of the manufacturer as to whether the declared noise level of sewing units and systems is based on the noise emission of batches of machines, or a single or individual machine.

Examples of the recommended dual number declaration of noise emission values in declarations of noise emission conforming to this standard and using the designation code given of C.8 are given hereafter.

EXAMPLE 1 Machines according to C.6.2 (CA)

- Equivalent continuous emission sound pressure level (L_{pA}) at the workstation:
A-weighted value of 82 dB; $K_{pA} = 2,5$ dB; according to ISO 10821-C.6.2- ISO 11204 GR2 at 3 500 stitches/min.

EXAMPLE 2 Machines according to C.6.2 (CA)

- Equivalent continuous emission sound pressure level (L_{pA}) at the workstation:
A-weighted value of 86 dB; $K_{pA} = 2,5$ dB; according to ISO 10821-C.6.2- ISO 11204 GR2 at 5 000 stitches/min;
- Sound power level (L_{WA}):
A-weighted value 91 dB; $K_{WA} = 2,5$ dB; according to ISO 10821-C.6.2- ISO 9614-1 GR2 at 5 000 stitches/min.

EXAMPLE 3 Machines according to C.6.3 (CB)

- Equivalent continuous emission sound pressure level (L_{pA}) at the workstation:
A-weighted value of 78 dB; $K_{pA} = 2,5$ dB; according to ISO 10821-C.6.3- ISO 11204 GR2, at sewing cycle:
15 s ON and 10 s OFF.

EXAMPLE 4 Machines according to C.6.3 (CB)

- Equivalent continuous emission sound pressure level (L_{pA}) at the workstation:
A-weighted value of 78 dB; $K_{pA} = 2,5$ dB; according to ISO 10821-C.6.3-ISO 11204 GR2, at 3 500 stitches/min for the sewing cycle:
12 s ON and 19 s OFF.

EXAMPLE 5 Machines according to C.6.3 (CB)

- Equivalent continuous emission sound pressure level (L_{pA}) at the workstation:
A-weighted value of 86 dB; $K_{pA} = 2,5$ dB; according to ISO 10821-C.6.3- ISO 11204 GR3 at 4 000 stitches/min;
- Sound power level (L_{WA}):
A-weighted value of 91 dB; $K_{WA} = 2,5$ dB; according to ISO 10821-C.6.3-ISO 9614-1 GR3 at 4 000 stitches/min for the sewing cycle:
18 s ON and 3 s OFF.

EXAMPLE 6 Machines according to C.6.3 (CB)

- Maximum emission sound pressure level ($L_{pA,max}$) for an undefined workstation:
A-weighted value of 82 dB; $K_{pA} = 2,5$ dB; according to ISO 10821-C.6.3-ISO 11204 GR2 at 5 000 stitches/min for the sewing cycle:
8 s ON and 2 s OFF.

EXAMPLE 7 Machines of large size according to C.6.3 (CB)

- Equivalent continuous emission sound pressure level (L_{pA}):
A-weighted value of 86 dB; $K_{pA} = 2,5$ dB; according to ISO 10821-C.6.3-ISO 11204 GR2, at 6 500 stitches/min for the sewing cycle:
- 1 m distance average emission sound pressure level ($L_{pA, 1 m}$):
A-weighted value of 84 dB; $K_{pA} = 2,5$ dB; according to ISO 10821-C.6.3-ISO 11204 GR2, at 6 500 stitches/min for the sewing cycle:
50 s ON and 10 s OFF.

EXAMPLE 8 Machines of large size according to C.6.3 (CB) without defined workstation

- Maximum emission sound pressure level ($L_{pA,max}$):
A-weighted value of 87 dB; $K_{pA} = 2,5$ dB; according to ISO 10821-C.6.3-ISO 11204 GR2, at 900 stitches/min for the sewing cycle:
- 1 m distance emission sound pressure level ($L_{pA, 1 m}$):
A-weighted value of 84 dB; $K_{pA} = 2,5$ dB; according to ISO 10821-C.6.3-ISO 11204 GR2, at 900 stitches/min for the sewing cycle:
50 s ON and 10 s OFF.

EXAMPLE 9 Machines having a sewing cycle with a rate > 9:1 (running time to stopping time) according to C.6.3 (CB)

- Equivalent continuous emission sound pressure level (L_{pA}):
A-weighted value of 79 dB; $K_{pA} = 2,5$ dB; according to ISO 10821-C.6.3-ISO 11204 at 2 000 stitches/min.

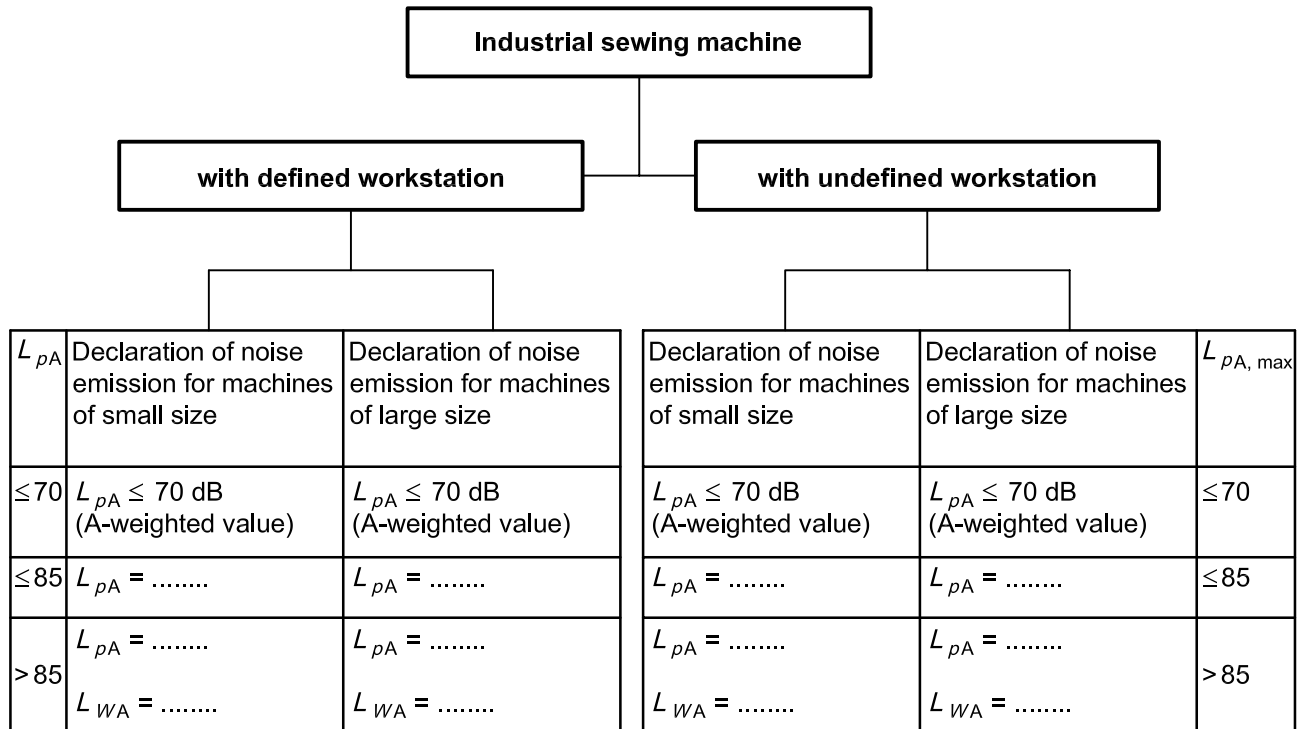

Values (see 5.2.4.2)

L_{pA} equivalent continuous A-weighted emission sound pressure level at workstations.

$L_{pA, 1 m}$ 1 m measurement surface sound pressure level.

L_{WA} A-weighted sound power level.

$L_{pA, max}$ maximum A-weighted emission sound pressure level at a distance of 1 m and 1,6 m above the floor.

Figure I.1 — Declaration of values depending on workstation, size of machine and magnitude of noise emission

Annex J (informative)

Examples of noise reduction measures at the design stage

Noise reduction measures include the following:

- selecting power sources and transmissions which allow quiet speed regulation;
- keeping the speed as low as possible;
- isolating vibration sources within the sewing unit or system;
- ensuring that cover panels and inspection hatches on machines are stiff and well damped;
- vibration-isolating machines with stiff and independent frames, placing the machine on a stable foundation with an elastic separating layer such as rubber blocks or steel springs;
- vibration-isolating panels, wherever possible, in order to minimize radiation of structure borne noise, with panels elastically mounted on the machine frame, thus reducing the vibration level transmitted to them, or, alternatively, panels coated with a special damping material;
- avoidance of air flow over cavities;
- mounting noise attenuators (e.g. mufflers) on any air exhaust openings;
- adding masses to relevant points;
- reducing masses at moving parts;
- optimizing balance of gears;
- sound insulation (airborne sound) — when a sound meets a wall or partition, only a small fraction of the sound energy passes through, while most of the energy is reflected, a wall with 10 dB insulation allowing 10 % of the energy to pass through (e.g. covers, housings);
- sound damping — structure-borne sound is absorbed when propagating through damping materials such as visco-elastic materials, grey cast iron, wood;
- active cancellation of repetitive machinery noise.

This list of examples of measures for reducing noise at the source serves only as a guide and is not exhaustive.

Annex K (normative)

Written warning — Languages

As part of the configuration of the Form B warning sign specified in B.3, the text in the appropriate language in accordance with Table K.1 shall be used for the written warning of residual risk specified in B.2 and for the warning sign according to Figure B.2, and in Areas 1 and 2 of the sign shown in Figure B.4.

For identification purposes, the language symbols shall always be used in accordance with ISO 639 for each translation.

Table K.1 — Written residual risk warning in a variety of languages

Language	Field	Text
German (de)	1	ACHTUNG
	2	Nicht ohne Fingerabweiser und Schutzeinrichtungen arbeiten. Vor Einfädeln, Spulenwechsel, Nadelwechsel, Reinigen usw. Hauptschalter ausschalten. de
English (en)	1	CAUTION
	2	Do not operate without finger guard and safety devices. Before threading, changing bobbin and needle, cleaning etc. switch off main switch. en
French (fr)	1	ATTENTION
	2	Ne pas travailler sans garde-doigts et dispositifs de protection. Mettre la machine hors circuit avant de l'enfiler, de changer l'aiguille, la canette, de la nettoyer, etc. fr
Spanish (es)	1	ATENCIÓN
	2	No trabaje sin salvaderos ni sin los dispositivos e protección. Antes del enhebrado, cambio de la canilla, cambio de la aguja y de la limpieza etc., desconectar el interruptor general. es

Table K.1 (Continued)

Language	Field	Text
Dutch (nl)	1	ATTENTIE
	2	Niet zonder vingerafwijzer en veiligheidsinrichtingen werken. Voor het inrijgen, spoelenwisselen, naaldwisselen, schoonmaken, enz. de hoofdschakelaar uitschakelen. nl
Italian (it)	1	ATTENZIONE
	2	E'obbligatorio l'uso del mezzi di protezione antinfortunistica in dotazione alla macchina. Prima di effettuare l'infilatura o regolazioni sulla macchina, spegnere sempre l'interruttore principale. it
Danish (da)	1	ADVARSEL
	2	Benyt ikke maskinen uden fingerbeskytter og beskyttelsesanordning. Før trådning, spole- og nåleskift, rengøring m. m. skal maskinen slukkes på hovedafbryderen. da
Finnish (fi)	1	VAROITUS
	2	Älä käytä konetta ilman sormisuojausta ja muita turvalaitteita. Katkaise virta pääkatkaisimesta ennen langanpujotusta, puolan- ja neulanvaihtoa koneen puhdistusta jne. fi
Swedish (sv)	1	OBSERVERA
	2	Maskinen får inte användas utan fingerskydd och andra nödvändiga skydd. Koppla bort strömmen från maskinens huvudavbrytare före trådning, spuloch nålbyte, rengöring osv. sv
Polish (pl)	1	UWAGA
	2	Zabrania się pracy bez ochroniacza palców i wskazanych środków ochrony pracy. Przed założeniem nitki, wymiana szpuli i igły, czy też czyszczeniem maszyny itd. wyłączyć maszynę.

Table K.1 (continued)

Language	Field	Text
Czech (cs)	1	POZOR
	2	Nepracujte bez chrániče prstů a ostatních ochranných zařízení. Před navlékáním, výměnou civky nebo jehly, čišťením atd. vypněte hlavní vypínač. cs
Russian (ru)	1	ВНИМАНИЕ
	2	Запрещается работать без предохранителя иглы и защитных устройств. Перед заправкой нити; заменой иглы или шпуль, чисткой машины и т.д. выключить автомат. ru
Hungarian (hu)	1	FIGYELEM
	2	Ne dolgozzon ujjvédő és védőberendezések nélkül. Befűzés, orsó és tűcsere, valamint tisztítás, stb. előtt a főkapcsolót kapcsolja ki. hu
Japanese (ja)	1	注意
	2	指ガードや安全上の保護装置なしではミシンの操作をしないで下さい。 糸通し、ボビンや針の交換、掃除を行なう時は電源スイッチをかならず切ってください。 ja
Turkish (tr)	1	DIKKAT
	2	Parmak koruyucusu ve güvenlik tertibatı olmadan çalışmayın. İğneye iplik geçirmeden, bobin ve iğne değiştirmeden, temizlik yapmadan vs. evvel ana şalteri kapatın. tr
Portuguese (pt)	1	ATENÇÃO
	2	Não trabalhar sem guarda-dedo e dispositivos protectores. Antes do enfiar, da mudança de bobina, mudança de agulha, da limpeza, etc., desligar Interruptor Principal. pt

Table K.1 (continued)

Language	Field	Text
Arabic (ar)	1	انتبه
	2	لا تعمل بدون واقعي الاصابع وتجهيزه الامان. اهلق المفتاح الرئيسي قبل وضع الخيط بالابرة، وقبل تبديل المكوك والابرة وقبل التنظيف وغير ذلك. ar
Greek (el)	1	ΠΡΟΣΟΧΗ
	2	Μην εργάζεσθε χωρίς αποκρουστήρα δακ- τύλων και προστατευτικές εγκαταστάσεις. Πριν το πέραςμα κλωστής, την αλλαγή καρουλιού, βελόνας, το καθάρισμα κλπ, σβήσατε τον κυρίως διακόπτη. el

Annex L (informative)

Ergonomic principles

The application of ergonomic principles to work systems is specified in ISO 6385. The work system is derived from a concept that combines operators, work equipment (including machinery), work space, work process, work task, management and organization, and the interactions between them.

To be able to achieve an efficient, healthy and safe interaction with work equipment, ergonomic principles as well as technical safety requirements should be taken into account during the design process.

The observance of ergonomic principles applies not only to the use of work equipment, but also to its installation, adjustment, maintenance, cleaning, repair and transport. Design details influence one another, so any interaction between them should be considered during the design process. For this reason, design focuses essentially on the interaction between the operator and the work equipment: hence the division of functions and labour between operator and work equipment. The objective is to design a work system that is consistent with human capabilities. This requires a task analysis in the design process.

Work equipment should be designed taking particular account of the bodily dimensions of the expected user population of operators. The following anthropometric principles and data should be observed:

- bodily dimensions (both static and dynamic) of adults;
- ranges of body dimensions and joint movements;
- anthropometric templates, models and computer-aided models;
- safety distances;
- dimensions for access (for use, repair and maintenance).

In the design of work equipment the following principles should be observed.

- a) The operating height or other functional dimensions of equipment should fit the operator and the type of work being performed, for example, by being adjustable.
- b) The type, location and adjustability of any seating provided should be appropriate to the dimensions of the operator, and to the functions the operator performs.
- c) Sufficient space should be provided for all body parts, to allow for the movements necessary to perform the task, and to allow for access and changes in posture.
- d) The handles and pedals of equipment should suit the functional anatomy of the hand or foot, and the dimensions of the operator population. For hand-held equipment, handles should be designed to ensure the operator grips the equipment correctly.
- e) Frequently used control actuators, grips and pedals should be placed within easy reach of the hands, feet or both when the operator is in a normal operating position. Other important control actuators (e.g. emergency stops) should be within easy reach of the operator, whereas less frequently used controls should be merely within reach, unless the task requires otherwise.
- f) There should be sufficient space between the back of one work table and the front of the next work table to allow the operator to carry out the necessary functions of the job without risk of injury to other employees. A minimum space of 750 mm is recommended.
- g) The use of an adjustable sewing machine stand and chair is recommended, so that the sewing unit may be adapted to each operator and thus avoid injury to the whole body caused by incorrect sitting posture.

Bibliography

- [1] ISO 11111, *Safety requirements for textile machinery*
- [2] ISO 11161, *Industrial automation systems — Safety of integrated manufacturing systems — Basic requirements*
- [3] ISO/TR 11688-1, *Acoustics — Recommended practice for the design of low-noise machinery and equipment — Part 1: Planning*
- [4] IEC 60335-2-28, *Household and similar electrical appliances — Safety — Part 2-28: Particular requirements for sewing machines*
- [5] IEC 60529, *Degrees of protection provided by enclosures (IP Code)*
- [6] ISO 2972:1979, *Numerical control of machines — Symbols*
- [7] ISO 4814, *Household sewing machines — Determination of stability of needle thread tension*
- [8] ISO 4815, *Household sewing machines — Determination of sewing capacity*
- [9] ISO 4817, *Household sewing machines — Determination of directional stability (drift)*
- [10] ISO 4818, *Household sewing machines — Determination of creep of one ply of material over another*
- [11] ISO 4819, *Household sewing machines — Determination of reproducibility of stitch length setting*
- [12] ISO 5232, *Graphical symbols for textile machinery*
- [13] ISO 6385, *Ergonomic principles in the design of work systems*
- [14] ISO 7000, *Graphical symbols for use on equipment — Index and synopsis*
- [15] ISO 7114, *Household sewing machines — Numerical classification*
- [16] ISO 7115, *Sewing machines — Vocabulary, classification and technical characteristics*
- [17] ISO 8678, *Cup head square neck bolts with small head and short neck — Product grade B*
- [18] ISO 9902, *Textile machinery acoustics — Determination of sound pressure levels and sound power levels emitted by textile machines — Engineering and survey methods*
- [19] ISO 10218, *Manipulating industrial robots — Safety*
- [20] ISO/TR 10488, *Graphical symbols incorporating arrows — Synopsis*
- [21] ISO/TR 11065, *Industrial automation glossary*
- [22] ISO/TR 11688-2, *Acoustics — Recommended practice for the design of low-noise machinery and equipment — Part 2: Introduction to the physics of low-noise design*
- [23] ISO 13850, *Safety of machinery — Emergency stop — Principles for design*
- [24] ISO 13855, *Safety of machinery — Positioning of protective equipment with respect to the approach speeds of parts of the human body*

- [25] ISO 14118, *Safety of machinery — Prevention of unexpected start-up*
- [26] ISO 14119, *Safety of machinery — Interlocking devices associated with guards — Principles for design and selection*
- [27] ISO 14120, *Safety of machinery — Guards — General requirements for the design and construction of fixed and movable guards*
- [28] ISO/IEC Guide 51, *Safety aspects — Guidelines for their inclusion in standards*
- [29] IEC 60417 (all parts), *Graphical symbols for use on equipment*
- [30] IEC 61672 (all parts), *Electroacoustics — Sound level meters*
- [31] IEC 60804, *Integrating-averaging sound level meters*
- [32] EN 614-1, *Safety of machinery — Ergonomic design principles — Part 1: Terminology and general principles*
- [33] EN 982, *Safety of machinery — Safety requirements for fluid power systems and their components — Hydraulics*
- [34] EN 983, *Safety of machinery — Safety requirements for fluid power systems and their components — Pneumatics*

1

ICS 61.080

Price based on 76 pages