**Mechanical vibration — Evaluation of
machine vibration by measurements on
non-rotating parts —**

Part 3:

**Industrial machines with nominal power
above 15 kW and nominal speeds
between 120 r/min and 15 000 r/min when
measured *in situ***

*Vibrations mécaniques — Évaluation des vibrations des machines par
mesurages sur les parties non tournantes —*

*Partie 3: Machines industrielles de puissance nominale supérieure à
15 kW et de vitesse nominale de fonctionnement entre 120 r/min et
15 000 r/min, lorsqu'elles sont mesurées in situ*



PDF disclaimer

This PDF file may contain embedded typefaces. In accordance with Adobe's licensing policy, this file may be printed or viewed but shall not be edited unless the typefaces which are embedded are licensed to and installed on the computer performing the editing. In downloading this file, parties accept therein the responsibility of not infringing Adobe's licensing policy. The ISO Central Secretariat accepts no liability in this area.

Adobe is a trademark of Adobe Systems Incorporated.

Details of the software products used to create this PDF file can be found in the General Info relative to the file; the PDF-creation parameters were optimized for printing. Every care has been taken to ensure that the file is suitable for use by ISO member bodies. In the unlikely event that a problem relating to it is found, please inform the Central Secretariat at the address given below.



COPYRIGHT PROTECTED DOCUMENT

© ISO 2009

All rights reserved. Unless otherwise specified, no part of this publication may be reproduced or utilized in any form or by any means, electronic or mechanical, including photocopying and microfilm, without permission in writing from either ISO at the address below or ISO's member body in the country of the requester.

ISO copyright office
Case postale 56 • CH-1211 Geneva 20
Tel. + 41 22 749 01 11
Fax + 41 22 749 09 47
E-mail copyright@iso.org
Web www.iso.org

Published in Switzerland

Contents

Page

Foreword	iv
Introduction.....	v
1 Scope	1
2 Normative references	2
3 Measurement procedures and operational conditions	2
4 Machine classification	5
5 Evaluation	6
Annex A (normative) Evaluation zone boundaries	10
Bibliography	12

Foreword

ISO (the International Organization for Standardization) is a worldwide federation of national standards bodies (ISO member bodies). The work of preparing International Standards is normally carried out through ISO technical committees. Each member body interested in a subject for which a technical committee has been established has the right to be represented on that committee. International organizations, governmental and non-governmental, in liaison with ISO, also take part in the work. ISO collaborates closely with the International Electrotechnical Commission (IEC) on all matters of electrotechnical standardization.

International Standards are drafted in accordance with the rules given in the ISO/IEC Directives, Part 2.

The main task of technical committees is to prepare International Standards. Draft International Standards adopted by the technical committees are circulated to the member bodies for voting. Publication as an International Standard requires approval by at least 75 % of the member bodies casting a vote.

Attention is drawn to the possibility that some of the elements of this document may be the subject of patent rights. ISO shall not be held responsible for identifying any or all such patent rights.

ISO 10816-3 was prepared by Technical Committee ISO/TC 108, *Mechanical vibration, shock and condition monitoring*, Subcommittee SC 2, *Measurement and evaluation of mechanical vibration and shock as applied to machines, vehicles and structures*.

This second edition cancels and replaces the first edition (ISO 10816-3:1998). The main change is the deletion of pumps from the scope, which now are dealt with in ISO 10816-7.

ISO 10816 consists of the following parts, under the general title *Mechanical vibration — Evaluation of machine vibration by measurements on non-rotating parts*:

- *Part 1: General guidelines*
- *Part 2: Land-based steam turbines and generators in excess of 50 MW with normal operating speeds of 1 500 r/min, 1 800 r/min, 3 000 r/min and 3 600 r/min*
- *Part 3: Industrial machines with nominal power above 15 kW and nominal speeds between 120 r/min and 15 000 r/min when measured in situ*
- *Part 4: Gas turbine sets with fluid-film bearings*
- *Part 5: Machine sets in hydraulic power generating and pumping plants*
- *Part 6: Reciprocating machines with power ratings above 100 kW*
- *Part 7: Rotodynamic pumps for industrial applications, including measurements on rotating shafts*

Introduction

ISO 10816-1 is the basic document describing the general requirements for evaluating the vibration of various machine types when the vibration measurements are made on non-rotating parts. This part of ISO 10816 provides specific guidance for assessing the severity of vibration measured on bearings, bearing pedestals, or housings of industrial machines when measurements are made *in situ*.

Two criteria are provided for assessing the machine vibration. One criterion considers the magnitude of the observed vibration; the second considers the changes in the magnitude. It must be recognized, however, that these criteria do not form the only basis for judging the severity of vibration. For some machine types, it is also common to judge the vibration based on measurements taken on the rotating shafts. Shaft vibration measurement requirements and criteria are addressed in separate documents, namely ISO 7919-1^[1] and ISO 7919-3^[2].

Mechanical vibration — Evaluation of machine vibration by measurements on non-rotating parts —

Part 3: Industrial machines with nominal power above 15 kW and nominal speeds between 120 r/min and 15 000 r/min when measured *in situ*

1 Scope

This part of ISO 10816 gives criteria for assessing vibration levels when measurements are made *in situ*. The criteria specified apply to machine sets having a power above 15 kW and operating speeds between 120 r/min and 15 000 r/min.

The machine sets covered by this part of ISO 10816 include:

- steam turbines with power up to 50 MW;
- steam turbine sets with power greater than 50 MW and speeds below 1 500 r/min or above 3 600 r/min (not included in ISO 10816-2);
- rotary compressors;
- industrial gas turbines with power up to 3 MW;
- generators;
- electrical motors of any type;
- blowers or fans.

NOTE However, the vibration criteria presented in this part of ISO 10816 are generally only applicable to fans with power ratings greater than 300 kW or fans which are not flexibly supported. As and when circumstances permit, recommendations for other types of fans, including those with lightweight sheet metal construction, will be prepared. Until such time, classifications can be agreed between the manufacturer and the customer, using results of previous operational experience, see also ISO 14694^[4].

The following are excluded from this part of ISO 10816:

- land-based steam turbine generator sets with power greater than 50 MW and speeds of 1 500 r/min, 1 800 r/min, 3 000 r/min or 3 600 r/min (see ISO 10816-2);
- gas turbine sets with power greater than 3 MW (see ISO 10816-4);
- machine sets in hydraulic power generating and pumping plants (see ISO 10816-5);
- machines coupled to reciprocating machines (see ISO 10816-6);

- rotodynamic pumps including integrated electric motors, i.e. where the impeller is mounted directly on the motor shaft or is rigidly attached to it (see ISO 10816-7);
- rotary positive displacement compressors (e. g. screw compressors);
- reciprocating compressors;
- reciprocating pumps;
- submerged motor-pumps;
- wind turbines.

The criteria of this part of ISO 10816 apply to *in situ* broad-band vibration measurements taken on the bearings, bearing pedestals, or housing of machines under steady-state operating conditions within the nominal operating speed range. They relate to both acceptance testing and operational monitoring. The evaluation criteria of this part of ISO 10816 are designed to apply to both continuous and non-continuous monitoring situations.

This part of ISO 10816 encompasses machines which may have gears or rolling element bearings, but does not address the diagnostic evaluation of the condition of those gears or bearings.

The criteria are applicable only for the vibration produced by the machine set itself and not for vibration which is transmitted to the machine set from external sources.

2 Normative references

The following referenced documents are indispensable for the application of this document. For dated references, only the edition cited applies. For undated references, the latest edition of the referenced document (including any amendments) applies.

ISO 496, *Driving and driven machines — Shaft heights*

ISO 2954, *Mechanical vibration of rotating and reciprocating machinery — Requirements for instruments for measuring vibration severity*

ISO 10816-1, *Mechanical vibration — Evaluation of machine vibration by measurements on non-rotating parts — Part 1: General guidelines*

3 Measurement procedures and operational conditions

3.1 General

The general measurement procedures are in accordance with ISO 10816-1, subject to the recommendations specified below.

3.2 Measurement equipment

The measurement equipment shall be capable of measuring broad-band root-mean-square (r.m.s.) vibration with flat response over a frequency range of at least 10 Hz to 1 000 Hz in accordance with the requirements of ISO 2954. Depending on the vibration criteria, this may require measurements of displacement or velocity or combinations of these (see ISO 10816-1). However, for machines with speeds approaching or below 600 r/min, the lower limit of the flat response frequency range shall not be greater than 2 Hz.

NOTE If the measurement equipment is also to be used for diagnostic purposes, an upper frequency limit higher than 1 000 Hz may be necessary.

Care should be taken to ensure that the measuring system is not influenced by environmental factors such as:

- temperature variations;
- magnetic fields;
- sound fields;
- power source variations;
- transducer cable length;
- transducer orientation.

Particular attention should be given to ensure that the vibration transducers are correctly mounted and that such mountings do not degrade the accuracy of the measurements.

3.3 Measurement locations

Measurements will usually be taken on exposed parts of the machine that are normally accessible. Care shall be taken to ensure that measurements reasonably represent the vibration of the bearing housing and do not include any local resonances or amplification. The locations and directions of vibration measurements shall be such that they provide adequate sensitivity to the machine dynamic forces. Typically, this will require two orthogonal radial measurement locations on each bearing cap or pedestal, as shown in Figure 1 (for horizontally mounted machines) and Figure 2 (for vertically mounted machines).

NOTE Figure 2, which is taken from IEC 60034-14:2003^[5], shows a motor mounted vertically on a solid steel plate or flange (e.g. of a driven machine) with a bore hole in the centre of the shaft extension. The main purpose of this figure is to identify the measuring points for a vertical machine.

The transducers may be placed at any angular position on the bearing housings or pedestals. Vertical and horizontal directions are usually preferred for horizontally mounted machines. For vertical or inclined machines, the location that gives the maximum vibration reading, usually in the direction of the elastic axis, shall be one of those used. In some cases it may be recommended to measure also in the axial direction (see 5.2.4). The specific locations and directions shall be recorded with the measurement.

A single transducer may be used on a bearing cap or pedestal in place of the more typical pair of orthogonal transducers if it is known to provide adequate information on the magnitude of the machine vibration. However, caution should be observed when evaluating vibration from a single transducer at a measurement plane since it may not be oriented to provide a reasonable approximation to the maximum value at that plane.

3.4 Continuous and non-continuous monitoring

It is common practice on large or critical machinery to have installed instrumentation for continuous on-line monitoring of vibration values at key measurement points. For many machines, mainly those of small size or power, continuous monitoring of the vibration parameters is not necessarily carried out. Changes in unbalance, bearing performance, alignment, etc. can be detected with sufficient reliability from periodic measurements with permanently installed or hand-held instruments. The use of computers for trend analysis and warning against malfunctions is also becoming more common.

3.5 Operational conditions

Measurements shall be carried out when the rotor and the main bearings have reached their normal steady-state operating temperatures and with the machine running under specified conditions, for example at rated speed, voltage, flow, pressure and load.

On machines with varying speeds or loads, measurements shall be made at all conditions at which the machine would be expected to operate for prolonged periods. The maximum measured value under these conditions shall be considered representative of vibration severity.

If the measured vibration is greater than the acceptance criteria allowed and excessive background vibration is suspected, measurements should be made with the machine shut down to determine the degree of external influence. If the vibration with the machine stationary exceeds 25 % of the value measured when the machine is running, corrective action may be necessary to reduce the effect of background vibration.

NOTE In some cases the effect of background vibration may be nullified by spectrum analysis or by eliminating the offending external source.

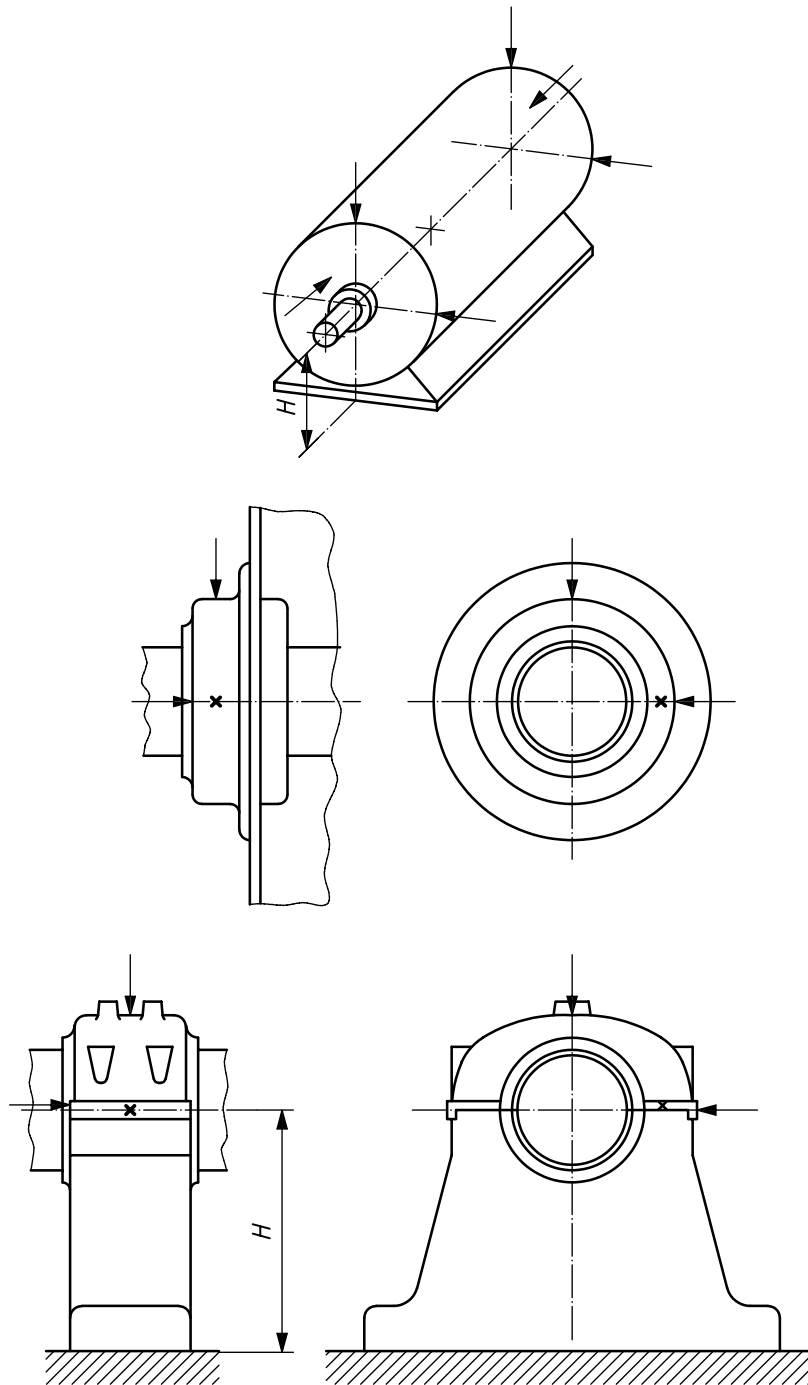

NOTE Measurements to be made at the bearing housing or, if not accessible, then at positions as close as possible to the bearing housings which provide adequate sensitivity to the machine dynamic forces.

Figure 1 — Measuring points for a horizontally mounted machine

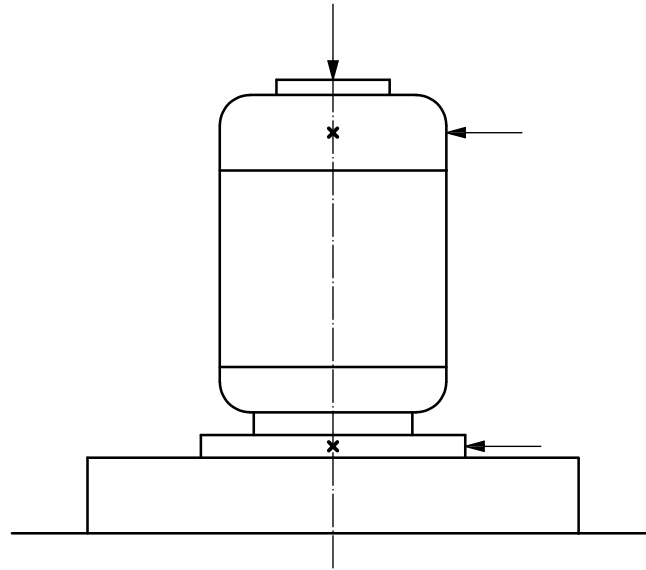

NOTE Measurements to be made at the bearing housing or, if not accessible, then at positions as close as possible to the bearing housings which provide adequate sensitivity to the machine dynamic forces.

Figure 2 — Measuring points for a vertically mounted machine

4 Machine classification

4.1 General

In this part of ISO 10816, the vibration severity is classified according to the following parameters:

- machine type;
- rated power or shaft height;
- support system flexibility.

4.2 Classification according to machine type, rated power or shaft height

Significant differences in design, type or bearings and support structures require a separation into two different machine groups (the shaft height, H , is in accordance with ISO 496). Machines of these two groups may have horizontal, vertical or inclined shafts and can be mounted on rigid or flexible supports.

Group 1: Large machines with rated power above 300 kW; electrical machines with shaft height $H \geq 315$ mm.

These machines normally have sleeve bearings. The range of operating or nominal speeds is relatively broad and ranges from 120 r/min to 15 000 r/min.

Group 2: Medium-sized machines with a rated power above 15 kW up to and including 300 kW; electrical machines with shaft height $160 \text{ mm} \leq H < 315$ mm.

These machines normally have rolling element bearings and operating speeds above 600 r/min.

NOTE 1 The shaft height, H , of a machine is defined in accordance with ISO 496 as the distance, measured on the machine ready for delivery, between the centreline of the shaft and the base plane of the machine itself (see Figure 1).

NOTE 2 The shaft height of a machine without feet, or a machine with raised feet, or any vertical machine, is to be taken as the shaft height of a machine in the same basic frame, but of the horizontal shaft foot-mounting type. When the frame is unknown, half of the machine diameter should be used.

4.3 Classification according to support flexibility

Two conditions are used to classify the support assembly flexibility in specified directions:

- rigid supports;
- flexible supports.

These support conditions are determined by the relationship between the machine and foundation flexibilities. If the lowest natural frequency of the combined machine and support system in the direction of measurement is higher than its main excitation frequency (this is in most cases the rotational frequency) by at least 25 %, then the support system may be considered rigid in that direction. All other support systems may be considered flexible.

As typical examples, large and medium-sized electric motors, mainly with low speeds, would normally have rigid supports, whereas turbo-generators or compressors with power greater than 10 MW and vertical machine sets would usually have flexible supports.

In some cases, a support assembly may be rigid in one measuring direction and flexible in the other. For example, the lowest natural frequency in the vertical direction may be well above the main excitation frequency, while the horizontal natural frequency may be considerably less. Such a system would be stiff in the vertical plane but flexible in the horizontal. In such cases, the vibration should be evaluated in accordance with the support classification which corresponds to the measurement direction.

If the class of a machine-support system cannot be readily determined from drawings and calculation, it may be determined by testing.

5 Evaluation

5.1 General

ISO 10816-1 provides a general description of the two evaluation criteria used to assess vibration severity on various classes of machines. One criterion considers the magnitude of observed broad-band vibration; the second considers changes in magnitude, irrespective of whether they are increases or decreases.

5.2 Criterion I: Vibration magnitude

5.2.1 General

This criterion is concerned with defining limits for vibration magnitude consistent with acceptable dynamic loads on the bearings and acceptable vibration transmission into the environment through the support structure and foundation. The maximum vibration magnitude observed at each bearing or pedestal is assessed against the evaluation zones for the support class. The evaluation zones have been established from international experience.

5.2.2 Evaluation zones

The following evaluation zones are defined to permit a qualitative assessment of the vibration of a given machine and provide guidelines on possible actions.

Zone A: The vibration of newly commissioned machines normally falls within this zone.

Zone B: Machines with vibration within this zone are normally considered acceptable for unrestricted long-term operation.

Zone C: Machines with vibration within this zone are normally considered unsatisfactory for long-term continuous operation. Generally, the machine may be operated for a limited period in this condition until a suitable opportunity arises for remedial action.

Zone D: Vibration values within this zone are normally considered to be of sufficient severity to cause damage to the machine.

Numerical values assigned to the zone boundaries are not intended to serve as acceptance specifications, which shall be subject to agreement between the machine manufacturer and the customer. However, these values provide guidelines for ensuring that gross deficiencies or unrealistic requirements are avoided. In certain cases, there may be specific features associated with a particular machine which would require the use of different zone boundary values (higher or lower). In such cases, it is normally necessary for the manufacturer to explain the reasons for this and, in particular, to confirm that the machine would not be endangered by operating with higher vibration values.

5.2.3 Evaluation zone limits

The values for the zone boundaries which are given in Table A.1 and Table A.2 are based on the maximum broad-band values of velocity and displacement when measurements are taken from two orthogonally oriented radial transducers. Therefore when using these tables, the higher of each of the values measured from the two transducers in each measurement plane should be used. When the maximum measured values of velocity and displacement are compared to the corresponding values in Table A.1 and Table A.2, the severity zone which is most restrictive shall apply.

5.2.4 Axial vibration

It is not common practice to measure axial vibration on main radial load-carrying bearings during continuous operational monitoring. Such measurements are primarily used during periodic vibration surveys or for diagnostic purposes. Certain faults are more easily detected in the axial direction. Specific axial vibration criteria are at the moment only given in the case of thrust bearings where axial vibration correlates with axial pulsations which could cause damage to the axial load-carrying surfaces. The criteria of Table A.1 and Table A.2 apply to radial vibration on all bearings and to axial vibration on thrust bearings.

5.3 Criterion II: Change in vibration magnitude

This criterion provides an assessment of a change in vibration magnitude from a previously established reference value. A significant change in broad-band vibration magnitude may occur, which requires some action even though zone C of Criterion I has not been reached. Such changes can be instantaneous or progressive over time and may indicate incipient damage or some other irregularity. Criterion II is specified on the basis of the change in broad-band vibration magnitude occurring under steady-state operating conditions. Steady-state operating conditions should be interpreted to include small changes in the machine power or operational conditions.

When Criterion II is applied, the vibration measurements being compared shall be taken at the same transducer location and orientation, and under approximately the same machine operating conditions. Obvious changes in the normal vibration magnitudes, regardless of their total amount, should be investigated so that a dangerous situation may be avoided. When an increase or decrease in vibration magnitude exceeds 25 % of the upper value of zone B, as defined in Table A.1 and Table A.2, such changes should be considered significant, particularly if they are sudden. Diagnostic investigations should then be initiated to ascertain the reason for the change and to determine what further actions are appropriate.

NOTE The 25 % value is provided as a guideline for a significant change in vibration magnitude, but other values may be used based on experience with a specific machine.

5.4 Operational limits

For long-term operation, it is common practice to establish operational vibration limits. These limits take the form of ALARMS and TRIPS.

ALARMS: To provide a warning that a defined value of vibration has been reached or a significant change has occurred, at which remedial action may be necessary. In general, if an ALARM situation occurs, operation can continue for a period whilst investigations are carried out to identify the reason for the change in vibration and define any remedial action.

TRIPS: To specify the magnitude of vibration beyond which further operation of the machine may cause damage. If the TRIP limit is exceeded, immediate action should be taken to reduce the vibration or the machine should be shut down.

Different operational limits, reflecting differences in dynamic loading and support stiffness, may be specified for different measurement positions and directions.

5.4.1 Setting of ALARMS

The ALARM limits may vary considerably, up or down, for different machines. The values chosen will normally be set relative to a baseline value determined from experience for the measurement position or direction for that particular machine.

It is recommended that the ALARM limit be set higher than the baseline by an amount equal to 25 % of the upper limit of zone B. If the baseline is low, the ALARM may be below zone C.

Where there is no established baseline (for example with a new machine) the initial ALARM setting should be based either on experience with other similar machines or relative to agreed acceptance values. After a period of time, the steady-state baseline value will be established and the ALARM setting should be adjusted accordingly.

It is recommended that the ALARM limit not normally exceed 1,25 times the upper limit of zone B.

If the steady-state baseline changes (for example after a machine overhaul), the ALARM setting should be revised accordingly.

5.4.2 Setting of TRIPS

The TRIP limits will generally relate to the mechanical integrity of the machine and be dependent on any specific design features which have been introduced to enable the machine to withstand abnormal dynamic forces. The values used will, therefore, generally be the same for all machines of similar design and would not normally be related to the steady-state baseline value used for setting ALARMS.

There may, however, be differences for machines of different design and it is not possible to give clear guidelines for absolute TRIP limits. In general, the TRIP limit will be within zone C or D, but it is recommended that the TRIP limit not exceed 1,25 times the upper limit of zone C.

5.5 Supplementary procedures/criteria

The measurement and evaluation of machine vibration given in this part of ISO 10816 may be supplemented by shaft vibration measurements and the applicable criteria given in ISO 7919-3^[2]. It is important to recognize that there is no simple way to relate bearing housing vibration to shaft vibration, or vice versa. The difference between the shaft absolute and shaft relative measurements is related to the bearing housing vibration but may not be numerically equal to it because of phase angle differences. Thus, when the criteria of this part of ISO 10816 and those of ISO 7919-3^[2] are both applied in the assessment of machine vibration, independent shaft and bearing housing (or pedestal) vibration measurements shall be made. If application of the different criteria leads to different assessments of vibration severity, the more restrictive zone classification is considered to apply.

5.6 Evaluation based on vibration vector information

The evaluation considered in this part of ISO 10816 is limited to broad-band vibration without reference to frequency components or phase. This will, in most cases, be adequate for acceptance testing and for operational monitoring purposes. However, for long-term condition monitoring purposes and for diagnostics, the use of vibration vector information is particularly useful for detecting and defining changes in the dynamic state of the machine. In some cases, these changes would go undetected when using only broad-band vibration measurements (see, for example, ISO 10816-1).

Phase- and frequency-related vibration information is being used increasingly for monitoring and diagnostic purposes. The specification of criteria for this, however, is beyond the current scope of this part of ISO 10816.

Annex A (normative)

Evaluation zone boundaries

It has been found that vibration velocity is sufficient to characterize the zone boundary values of vibration over a wide range of machine types and machine operating speeds. The main evaluation quantity is therefore the overall r.m.s. value of vibration velocity.

NOTE In many cases, it was customary to measure vibration with instruments scaled to read peak rather than r.m.s. vibration values.

If the vibration wave form is basically a single sinusoid, a simple relationship exists between peak and r.m.s. values and the zone boundaries in the tables can be readily expressed in zero-to-peak values by multiplying by $\sqrt{2}$ or in peak-to-peak values by multiplying by $2\sqrt{2}$. Alternatively, the measured zero-to-peak vibration values can be divided by $\sqrt{2}$ and judged against the r.m.s. criteria of Table A.1 or Table A.2.

For many machines, it is common for the vibration to be predominantly at the machine's running frequency. For such cases and when peak rather than r.m.s. values of vibration are being measured, tables equivalent to Tables A.1 and A.2 can be constructed. The zone boundaries of the given tables are multiplied by a factor of $\sqrt{2}$ to produce such equivalent tables for assessing peak vibration severity if only one frequency is present.

It is recognized that the use of a single value of vibration velocity, regardless of frequency, can lead to unacceptably large vibration displacements. This is particularly so for machines with low operating speeds when the once-per-revolution vibration component is dominant. Similarly, constant velocity criteria for machines with high operating speeds, or with a significant vibration energy concentrated in a high-frequency range, can lead to unacceptably high acceleration values. Ideally, acceptance criteria should be provided in terms of displacement, velocity and acceleration, depending on the speed range and type of machine. At present, however, vibration zone boundary values are given only in terms of velocity and displacement. They are presented in the general form of Table A.1 and Table A.2 for the machine groups covered by this part of ISO 10816.

The limits apply to the broad-band r.m.s. values of vibration velocity and displacement in the frequency range from 10 Hz to 1 000 Hz, or for machines with speeds below 600 r/min from 2 Hz to 1 000 Hz. In most cases, it is sufficient to measure only vibration velocity. If the vibration spectrum is expected to contain low-frequency components the evaluation should be based on broad-band measurements of both velocity and displacement.

Machines of all groups can be installed on rigid or flexible supports. For both, different evaluation zone values are provided in Table A.1 and Table A.2. Guidelines for the support classification are given in Clause 4.

Table A.1 — Classification of vibration severity zones for machines of Group 1: Large machines with rated power above 300 kW and not more than 50 MW; electrical machines with shaft height $H \geq 315$ mm

Support class	Zone boundary	r.m.s. displacement	r.m.s. velocity
		μm	mm/s
Rigid	A/B	29	2,3
	B/C	57	4,5
	C/D	90	7,1
Flexible	A/B	45	3,5
	B/C	90	7,1
	C/D	140	11,0

Table A.2 — Classification of vibration severity zones for machines of Group 2: Medium-sized machines with rated power above 15 kW up to and including 300 kW; electrical machines with shaft height $160 \text{ mm} \leq H < 315$ mm

Support class	Zone boundary	r.m.s. displacement	r.m.s. velocity
		μm	mm/s
Rigid	A/B	22	1,4
	B/C	45	2,8
	C/D	71	4,5
Flexible	A/B	37	2,3
	B/C	71	4,5
	C/D	113	7,1

NOTE 1 These values apply to radial vibration measurements on all bearings, bearing pedestals, or housings of machines and to axial vibration measurements on thrust bearings under steady-state operating conditions at rated speed or within the specified speed range. They do not apply when the machine is undergoing a transient condition (i.e. changing speed or load).

NOTE 2 Different and/or higher values are possible for specific machines or special support and operating conditions. All such cases are subject to agreement between the manufacturer and the customer.

NOTE 3 At present it is not common practice to monitor the acceleration value of these machines. Information on acceleration values is welcome and users are encouraged to communicate to the national standards body in the country of origin for transmission to the secretariat of ISO/TC 108/SC 2.

Bibliography

- [1] ISO 7919-1, *Mechanical vibration of non-reciprocating machines — Measurements on rotating shafts and evaluation criteria — Part 1: General guidelines*
- [2] ISO 7919-3, *Mechanical vibration — Evaluation of machine vibration by measurements on rotating shafts — Part 3: Coupled industrial machines*
- [3] ISO 8579-2, *Acceptance code for gears — Part 2: Determination of mechanical vibrations of gear units during acceptance testing*
- [4] ISO 14694, *Industrial fans — Specifications for balance quality and vibration levels*
- [5] IEC 60034-14:2003, *Rotating electrical machines — Part 14: Mechanical vibration of certain machines with shaft heights 56 mm and higher — Measurement, evaluation and limits of vibration severity*

ICS 17.160; 21.020

Price based on 12 pages