



INTERNATIONAL STANDARD ISO 10791-3:1998
TECHNICAL CORRIGENDUM 1

Published 1999-11-15

INTERNATIONAL ORGANIZATION FOR STANDARDIZATION • МЕЖДУНАРОДНАЯ ОРГАНИЗАЦИЯ ПО СТАНДАРТИЗАЦИИ • ORGANISATION INTERNATIONALE DE NORMALISATION

Test conditions for machining centres —

Part 3:

Geometric tests for machines with integral indexable or continuous universal heads (vertical Z-axis)

TECHNICAL CORRIGENDUM 1

Conditions d'essai pour centres d'usinage —

Partie 3: Essais géométriques des machines à têtes universelles intégrées à indexage ou continues (axe Z vertical)

RECTIFICATIF TECHNIQUE 1

Technical Corrigendum 1 to International Standard ISO 10791-3:1998 was prepared by Technical Committee ISO/TC 39, *Machine tools*, Subcommittee SC 2, *Test conditions for metal cutting machine tools*.

Page 4

Replace Figure 1 with the following figure.

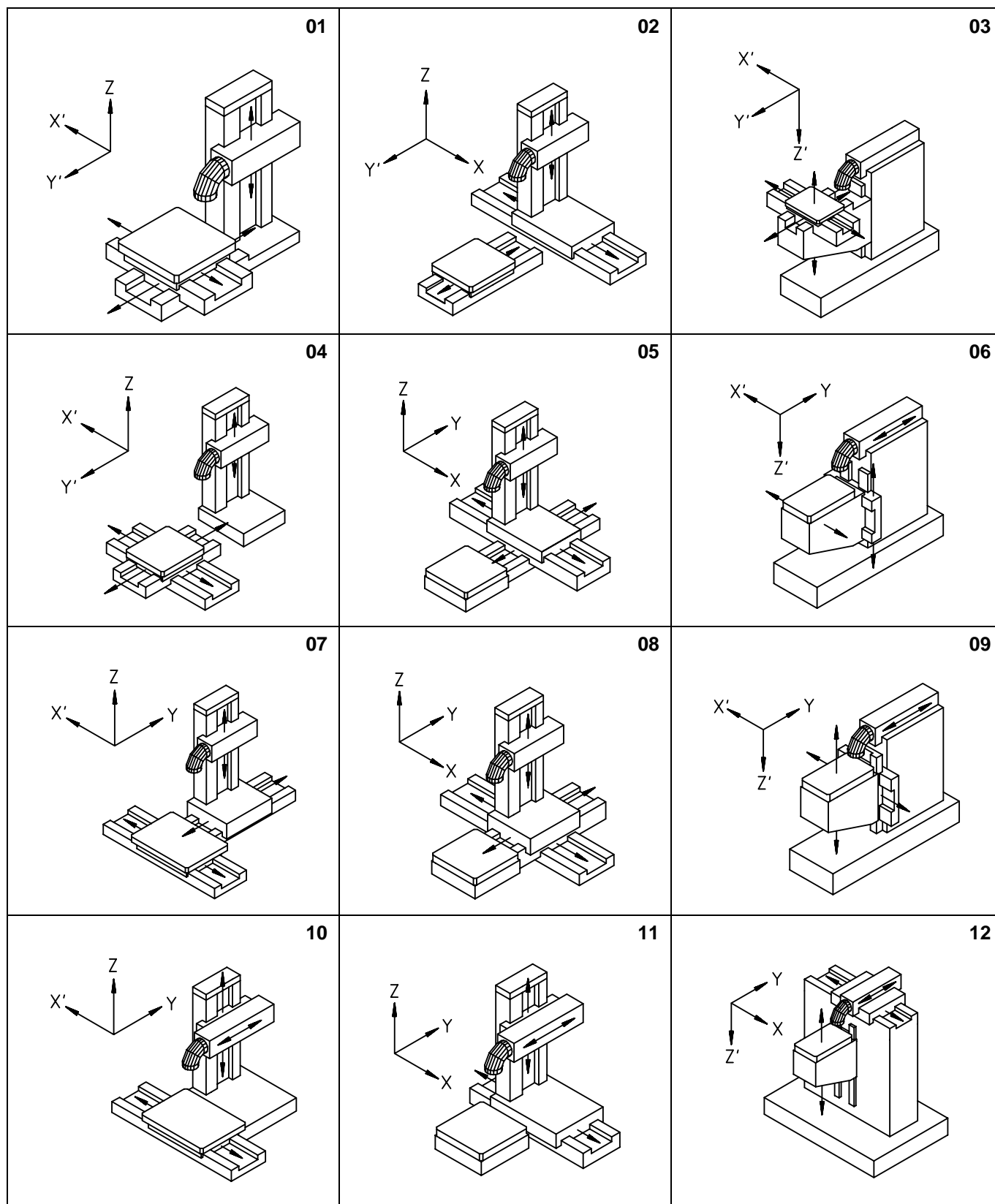

Figure 1

Replace Table 1 with the following table.

Table 1 — Classification of configurations of horizontal primary rotary axis machining centres

	X	X'	Y	Y'	Z	Z'
01		Table on its saddle		Table saddle	Spindle head	
02	Column			Table	Spindle head	
03		Table on its saddle		Table saddle		Knee
04		Table saddle		Table on its saddle	Spindle head	
05	Column on its saddle		Column saddle		Spindle head	
06		Knee	Spindle head			Knee saddle
07		Table	Column		Spindle head	
08	Column saddle		Column on its saddle		Spindle head	
09		Knee saddle	Spindle head			Knee
10		Table	Spindle head on its slide		Spindle head slide	
11	Column		Spindle head on its slide		Spindle head slide	
12	Spindle head slide		Spindle head on its slide			Knee