**Footwear — Test method for the
determination of the resistance of elastic
materials for footwear to repeated
extension — Fatigue resistance**

*Chaussures — Méthode d'essai pour la détermination de la résistance
des élastiques de chaussures à des extensions répétées — Résistance
à la fatigue*



PDF disclaimer

This PDF file may contain embedded typefaces. In accordance with Adobe's licensing policy, this file may be printed or viewed but shall not be edited unless the typefaces which are embedded are licensed to and installed on the computer performing the editing. In downloading this file, parties accept therein the responsibility of not infringing Adobe's licensing policy. The ISO Central Secretariat accepts no liability in this area.

Adobe is a trademark of Adobe Systems Incorporated.

Details of the software products used to create this PDF file can be found in the General Info relative to the file; the PDF-creation parameters were optimized for printing. Every care has been taken to ensure that the file is suitable for use by ISO member bodies. In the unlikely event that a problem relating to it is found, please inform the Central Secretariat at the address given below.



COPYRIGHT PROTECTED DOCUMENT

© ISO 2010

All rights reserved. Unless otherwise specified, no part of this publication may be reproduced or utilized in any form or by any means, electronic or mechanical, including photocopying and microfilm, without permission in writing from either ISO at the address below or ISO's member body in the country of the requester.

ISO copyright office
Case postale 56 • CH-1211 Geneva 20
Tel. + 41 22 749 01 11
Fax + 41 22 749 09 47
E-mail copyright@iso.org
Web www.iso.org

Published in Switzerland

Foreword

ISO (the International Organization for Standardization) is a worldwide federation of national standards bodies (ISO member bodies). The work of preparing International Standards is normally carried out through ISO technical committees. Each member body interested in a subject for which a technical committee has been established has the right to be represented on that committee. International organizations, governmental and non-governmental, in liaison with ISO, also take part in the work. ISO collaborates closely with the International Electrotechnical Commission (IEC) on all matters of electrotechnical standardization.

International Standards are drafted in accordance with the rules given in the ISO/IEC Directives, Part 2.

The main task of technical committees is to prepare International Standards. Draft International Standards adopted by the technical committees are circulated to the member bodies for voting. Publication as an International Standard requires approval by at least 75 % of the member bodies casting a vote.

Attention is drawn to the possibility that some of the elements of this document may be the subject of patent rights. ISO shall not be held responsible for identifying any or all such patent rights.

ISO 10768 was prepared by Technical Committee ISO/TC 216, *Footwear* and by Technical Committee CEN/TC 309, *Footwear* in collaboration, in accordance with the Vienna Agreement.

Footwear — Test method for the determination of the resistance of elastic materials for footwear to repeated extension — Fatigue resistance

1 Scope

This International Standard specifies a test method for the determination of the resistance of elastic materials for footwear, to repeated extension produced during normal walking. The test can be carried out before and after accelerated ageing. This method is applicable to any elastic material used for footwear.

2 Normative references

The following referenced documents are indispensable for the application of this document. For dated references, only the edition cited applies. For undated references, the latest edition of the referenced document (including any amendments) applies.

ISO 10765, *Footwear — Test method for the characterization of elastic materials — Tensile performance*

ISO 18454, *Footwear — Standard atmospheres for conditioning and testing of footwear and components for footwear*

3 Terms and definitions

For the purposes of this document, the following terms and definitions apply.

3.1

elastic

tape, cord or fabric containing rubber or a similar substance allowing it to stretch and return to its original shape

NOTE Generally elastic materials are used in upper construction in the quarters or in the straps to hold the shoe on the foot.

4 Apparatus and materials

4.1 Sewing machine, with a round point needle metric size 90s or 70s, a nylon or polyester thread (approximately tex 17/3) and operating at 6 stitches/cm.

4.2 Repeated extension machine, with a minimum separation of (60 ± 10) mm, a maximum separation that is fully adjustable up to a distance equal to the minimum separation plus 150 mm, a method of applying a simple harmonic reciprocating action to increase the distance between the clamps from the minimum to the maximum separation and back again at a rate of (60 ± 5) cycles per minute and a means of recording the number of cycles.

4.3 Chamber, at (70 ± 2) °C for the accelerated ageing process.

4.4 **Steel ruler or callipers.**

4.5 **Polyurethane (PU) coagulated woven fabric**, of thickness of approximately 1 mm.

5 Sampling and conditioning

5.1 Sampling

5.1.1 The dimensions of test pieces are shown in Figure 1.

5.1.2 Cut three test pieces of elastic, measuring (65 ± 5) mm. If accelerated ageing is going to be carried out, cut three more test pieces. The width dimension must be suitable to the dimension of the clamps so that the sample can be clamped properly in the fatigue equipment.

5.1.3 Mark on the test pieces a $(15 \pm 0,5)$ mm line parallel to both ends by means of the steel ruler (4.4).

5.1.4 For each test piece cut four pieces of the coagulated fabric, with the following dimensions:

— length of 30 mm;

— width equal to sample width plus 10 mm (minimum 30 mm).

5.1.5 On each of the square pieces, mark a line that is parallel to the width edge and 5 mm from it (AB, in Figure 1).

5.1.6 Stick a piece of double-sided tape on the uncoated side of one of the coated fabric squares. Place it on the elastic test piece so that the line drawn on the elastic is perfectly aligned with the edge of the square piece where the AB line has been drawn. Turn the sample around and place another coated fabric square on the elastic, now with the coated side facing upwards. The two coated fabric squares should be in line with each other. Press the assembly to ensure that they are bonded. Repeat the process on the other end of the test piece.

5.1.7 Prepare the other two samples in the same way.

5.1.8 Using the sewing machine (4.1), sew the three test pieces at each end, along the AB line.

5.2 Conditioning

Samples and test pieces shall be conditioned for at least 24 h at (23 ± 2) °C and (50 ± 5) % of relative humidity (RH) before testing, in accordance with ISO 18454.

Dimensions in millimetres

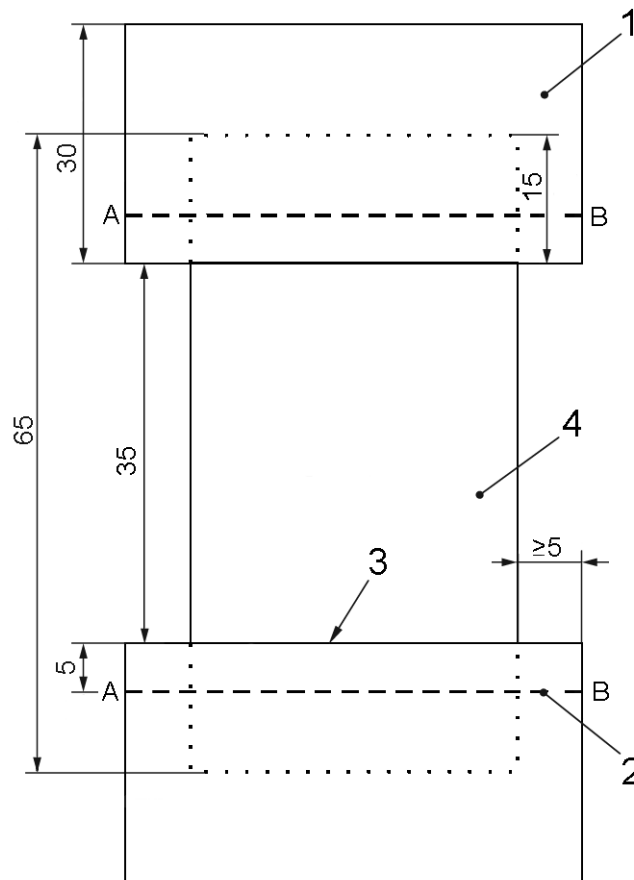
**Key**

- 1 coated fabric
- 2 stitching
- 3 line drawn on elastic
- 4 elastic

Figure 1 — Dimensions of a standard test piece in millimetres**6 Procedure**

6.1 Damage of the elastic is evaluated after being submitted to repeated extensions of 150 % of its initial length or until the limit of useful extension (see ISO 10765).

6.2 Once the test pieces are prepared, measure the distance between the seams at both ends as well as the test piece width, to the nearest 0,5 mm. There should not be more than a 2 mm difference in the measurements. Calculate the arithmetic mean of the three values to the nearest 0,5 mm.

6.3 Before starting the test, examine the test piece under bright lighting conditions and record the number of elastic threads of the sample.

6.4 The limit of useful extension of the elastic material is needed so as to know the maximum stretch that can be applied. It is determined in accordance with ISO 10765.

If the useful extension is $\geq 150\%$, the maximum stretch to apply is 150 %. If the useful extension is $< 150\%$, the maximum stretch to apply is equal to the useful extension value.

6.5 Clamp the test piece in the equipment. The jaws should be on the minimum separation, so that the length of the sample is at right angles to the edge of the jaws. When clamped, the test piece should be neither stretched nor slack. Furthermore, the seams must not be clamped.

6.6 Once the test piece is clamped, calibrate the equipment so that the maximum distance between the jaws during each cycle corresponds to the maximum elongation value.

6.7 Switch on the machine at a test speed of (60 ± 5) cycles per minute until 2 000 cycles have been completed. Then, examine the test piece again and record the amount of broken elastic threads, as well as any signs of visible damage, such as wrinkling.

6.8 If more than 10 % of the test piece's elastic threads are broken or if it has wrinkled severely, the test is complete.

6.9 If the test piece does not appear to be damaged, carry out another 2 000 cycles and examine it once more. Continue this process until 10 000 cycles have been carried out or until any damage appears.

6.10 Repeat the procedure for the other two samples.

6.11 When test pieces are subjected to ageing, store the cut test pieces at 70 °C for 7 d. Take out the samples after 7 d, and leave them to condition in a controlled atmosphere at (23 ± 2) °C and (50 ± 5) % relative humidity (RH), for at least 48 h. Prepare the test pieces and test them according to the procedure described in 6.1 to 6.10.

7 Expression of results

The results are expressed as a percentage of the broken threads at the end of the test and shall be calculated using Equation (1).

$$\% = \frac{n_b}{n_0} \times 100 \quad (1)$$

where

n_b is the number of elastic thread broken;

n_0 is the number of elastic thread at the start of the test.

The final result shall be the arithmetic mean of the three test pieces. If it is not possible to distinguish the elastic threads, the test result will be an evaluation of the material's damage after a determined number of cycles.

8 Test report

The test report shall include, at least, the following information:

- a) reference to this test standard (i.e. ISO 10768:2010);
- b) a full description of the elastic material;
- c) the total number of extension cycles;
- d) a description of damage [wrinkling, elastic threads broken (%), etc.];

- e) if accelerated ageing was carried out, the values of number of extension cycles and the amount of damage for the test after accelerated ageing;
- f) any deviations from this method.

ICS 61.060

Price based on 5 pages