**Footwear — Test methods for slide
fasteners — Resistance to repeated
opening and closing**

*Chaussures — Méthode d'essai pour les fermetures à glissière —
Résistance aux ouvertures et fermetures répétées*



COPYRIGHT PROTECTED DOCUMENT

© ISO 2016, Published in Switzerland

All rights reserved. Unless otherwise specified, no part of this publication may be reproduced or utilized otherwise in any form or by any means, electronic or mechanical, including photocopying, or posting on the internet or an intranet, without prior written permission. Permission can be requested from either ISO at the address below or ISO's member body in the country of the requester.

ISO copyright office
Ch. de Blandonnet 8 • CP 401
CH-1214 Vernier, Geneva, Switzerland
Tel. +41 22 749 01 11
Fax +41 22 749 09 47
copyright@iso.org
www.iso.org

Contents

	Page
Foreword	iv
1 Scope	1
2 Normative references	1
3 Terms and definitions	1
4 Principle	3
5 Apparatus and materials	3
6 Preparation of test specimens	4
7 Procedure	5
8 Test report	6

Foreword

ISO (the International Organization for Standardization) is a worldwide federation of national standards bodies (ISO member bodies). The work of preparing International Standards is normally carried out through ISO technical committees. Each member body interested in a subject for which a technical committee has been established has the right to be represented on that committee. International organizations, governmental and non-governmental, in liaison with ISO, also take part in the work. ISO collaborates closely with the International Electrotechnical Commission (IEC) on all matters of electrotechnical standardization.

The procedures used to develop this document and those intended for its further maintenance are described in the ISO/IEC Directives, Part 1. In particular the different approval criteria needed for the different types of ISO documents should be noted. This document was drafted in accordance with the editorial rules of the ISO/IEC Directives, Part 2 (see www.iso.org/directives).

Attention is drawn to the possibility that some of the elements of this document may be the subject of patent rights. ISO shall not be held responsible for identifying any or all such patent rights. Details of any patent rights identified during the development of the document will be in the Introduction and/or on the ISO list of patent declarations received (see www.iso.org/patents).

Any trade name used in this document is information given for the convenience of users and does not constitute an endorsement.

For an explanation on the meaning of ISO specific terms and expressions related to conformity assessment, as well as information about ISO's adherence to the WTO principles in the Technical Barriers to Trade (TBT) see the following URL: [Foreword - Supplementary information](#)

ISO 10751 was prepared by the European Committee Standardization (CEN) Technical Committee CEN/TC 309, *Footwear*, in collaboration with ISO Technical Committee TC 216, *Footwear*, in accordance with the agreement on technical cooperation between ISO and CEN (Vienna Agreement).

Footwear — Test methods for slide fasteners — Resistance to repeated opening and closing

1 Scope

This International Standard describes a method intended to determine the resistance of a slide fastener to repeated opening and closing. The method is applicable to all types of slide fastener with a teeth length greater than 80 mm.

2 Normative references

The following documents, in whole or in part, are normatively referenced in this document and are indispensable for its application. For dated references, only the edition cited applies. For undated references, the latest edition of the referenced document (including any amendments) applies.

ISO 18454, *Footwear — Standard atmospheres for conditioning and testing of footwear and components of footwear*

ISO 19952, *Footwear — Vocabulary*

3 Terms and definitions

For the purposes of this document, the terms and definitions given in ISO 19952 and the following apply.

3.1 slide fastener

means of securing two flexible materials consisting of interlockable teeth each attached to one of the opposing edges of two *tapes* (3.2) and movable slider that spans the interlocking teeth which when moved in one direction causes the *teeth* (3.5) of one tape to interlock with the teeth of the other tape

Note 1 to entry: When the *slider* (3.3) is moved in the opposite direction, it causes the teeth to disengage (see [Figure 1](#)).

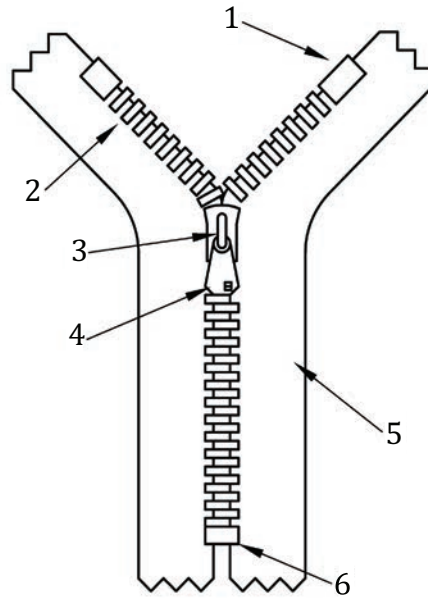

Key

- | | | | |
|---|----------|---|-------------|
| 1 | top stop | 4 | puller |
| 2 | teeth | 5 | tape |
| 3 | slider | 6 | bottom stop |

Figure 1 — Slide fastener

3.2

tape

fabric panels to support other *teeth* (3.5) of the *slide fastener* (3.1)

3.3

slider

means of drawing the two interlocking teeth together or apart as it traverses the length of the *teeth* (3.5)

3.4

puller

piece of plastic or metal attached to the *slider* (3.3) as a means of manual grip for the user to operate

3.5

teeth

individual component of the slide fastener or continuous plastic spiral which interlocks with an opposing element

3.6

end stop

top stop

terminal components of the teeth to prevent the *slider* (3.3) from disengaging from the *teeth* (3.5) and *tape* (3.2)

3.7

stringer

textile tape with an attached row of *teeth* (3.5) designed to interact with a row of similarly attached to another *tape* (3.2)

4 Principle

The free tapes at the open end of a test fastener are clamped together so that they are parallel. The fastener is held under tension along its length and across its width while it is repeatedly opened and closed. The test is stopped when the fastener has either failed or been subjected to a set number of cycles.

5 Apparatus and materials

5.1 A test machine with one or more stations each having the following.

5.1.1 A fixed clamp capable of firmly holding the closed end of the test fastener without causing damage to the teeth.

5.1.2 A free clamp capable of holding the open end of the test fastener without causing damage to the teeth and with the two free tapes held so that they are together (see [Figure 2](#)).

5.1.3 A clamping system capable of holding a (25 ± 2) mm length of both edges of the test fastener tapes so that

- a) the centre of the clamped length is a point $(82,5 \pm 2,0)$ mm from the free clamp ([5.1.2](#)), and
- b) the lateral movement of each clamp is restricted, by stops, to (6 ± 1) mm.

5.1.4 A means of applying a force, F_1 , as specified in [Table 1](#) to the free clamp ([5.1.2](#)) in a direction at 90° to and away from the clamping edge of clamp ([5.1.1](#)) (see [Figure 2](#)).

5.1.5 A means of applying a force, F_2 , as specified in [Table 1](#) to each of the clamps ([5.1.3](#)) in direction parallel to the clamping edge of clamp ([5.1.1](#)).

5.1.6 A device for holding the slider of the test fastener.

5.1.7 A method of applying a regular harmonic reciprocating motion to the device ([5.1.6](#)) with – stroke: $(63,5 \pm 1,5)$ mm, speed: (60 ± 6) cycles per minute (cycle/min).

5.1.8 A method of counting the number of cycles of the device ([5.1.6](#)) up to failure of the test specimen.

5.2 A device for measuring distances up to 300 mm to an accuracy of 1 mm. A steel rule is suitable.

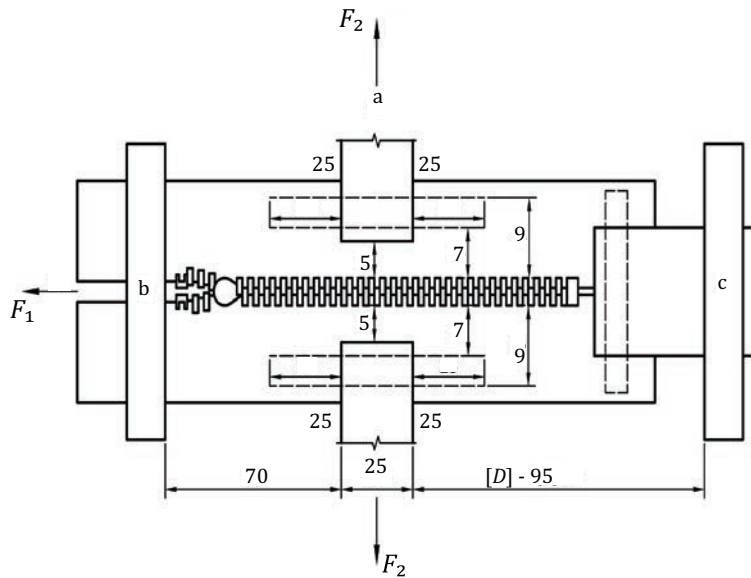

Key

- a clamp (5.1.2) or tab
- b clamp (5.1.2)
- c clamp (5.1.1)

Figure 2 — Clamping arrangement for test specimens

6 Preparation of test specimens

6.1 The test may be conducted with any number of test specimens, but a minimum of three is recommended. Condition the test specimens according to ISO 18454 for 24 h before testing and carry out the test in this environment.

6.2 If the test fastener is shorter than the minimum distance between the two clamps (5.1.1), and (5.1.2) then sew strips of either leather or fabric, minimum width 25 mm, to the closed ends of both tapes. The exact length of the strips will depend on the clamping system of the machine being used, but they should enable the fastener to be clamped in a position such that its slider does not make contact with the end stops during the test.

6.3 Mark a line across the width of each tape of the test fastener which is (4 ± 2) mm on the outer side of the end stops at the open end.

6.4 Mark a second line across the width of each tape, or attached strip (5.2), which is $[D] \pm 1$ mm from, and parallel to the line (6.3). If this second line passes close to an end stop which is sufficiently thick to make clamping difficult, then move the line towards the centre of the fastener until it is over the teeth and clear of the end stop. Then, move the line (6.3) until it is $[D] \pm 1$ mm from this second line.

6.5 For each test fastener, make a mark on the edge of both tapes that is $(82,5 \pm 2,0)$ mm from the line (6.3).

6.6 If the test fastener is narrower than the minimum distance between the two clamps (5.1.3), then for each test fastener

- a) cut two tabs of leather or fabric, minimum width 25 mm. The exact length of the strips will depend on the clamping system of the machine being used, and
- b) sew a tab (6.6.1) to the reverse edge of each tape so that the longitudinal centre line of the tab is at 90° to the edge of the teeth and is coincident with the point made in 6.5. Use two rows of stitching which are parallel to the edge of the test fastener teeth with one row (7,0 ± 0,5) mm and the other (9,0 ± 0,5) mm from the teeth. Both rows of stitching should be continued for at least 25 mm beyond either end of the tab.

7 Procedure

7.1 Secure the closed end of a test fastener, or any attached strip (6.2), in the clamp (5.1.1) so that the line (6.4) is aligned with the edge of the clamp.

7.2 Grip the open end of the test fastener with the clamp (5.1.2) so that the line (6.3) is aligned with the edge of the clamp.

7.3 Apply the longitudinal force, F_1 , specified in Table 1 to the clamp (5.1.2) so that the fastener is held under tension along its length.

7.4 If a tab was attached to the edge of each tape in 6.6, then grip a tab with each clamp (5.1.3). Otherwise, grip the edge of the tape in the clamp (5.1.3) ensuring that the point (6.5) is at the centre of the clamp, and the edge of the clamp is parallel to, and at least 5 mm from the edge of the teeth.

7.5 Tension the test fastener across its width by applying a force of F_2 , as specified in Table 1, to each of the two clamps (5.1.3) in a direction that is parallel to the clamping edge of clamp (5.1.1).

Ensure that the distance from the rear of each clamp (5.1.3) to the stop (5.1.3.2) with the test fastener closed is (6 ± 1) mm.

Table 1 — Longitudinal and lateral forces applied to test fastener

F_1 Longitudinal force (N)	F_2 Lateral force (N)
22	18
Tolerance on all forces ±1 N	

7.6 Clamp the test fastener slider in the device (5.1.6) and ensure that the stroke of the device is (63,5 ± 1,5) mm.

7.7 Repeat the procedure in 7.1 to 7.6 for any remaining test fasteners up to the number of test stations.

7.8 Reset the counter (5.1.8) and run the test machine (5.1) at a speed of (60 ± 6) cycles per minute (cycles/min).

7.9 When the test fastener(s) have either failed or been subjected to a specified number of cycles, remove them from the machine and record any damage such as the following:

- detachment of slider from one track;
- breakage of the puller;
- jamming or wear of the teeth;
- detachment or breakage of the teeth;
- stitch abrasion (sewn-on nylon teeth);

ISO 10751:2016(E)

- tearing of the tape.

Record the corresponding number(s) of cycles.

7.10 Repeat the procedure in [7.1](#) to [7.9](#) for any remaining test fasteners.

8 Test report

The test report shall include the following information:

- a) a reference to this International Standard, i.e. ISO 10751;
- b) a description of the fasteners tested;
- c) the date of testing;
- d) for each test slide fastener:
 - the number of cycles as recorded in [7.9](#);
 - the type(s) of damage as recorded in [7.9](#);
- e) any deviations from this test method.

