

INTERNATIONAL
STANDARD

ISO
10726

First edition
1992-04-15

**Portable chain-saws — Chain catcher —
Dimensions and mechanical strength**

*Scies à chaîne portatives — Enrouleur de chaîne — Dimensions et
résistance mécanique*



Reference number
ISO 10726:1992(E)

Foreword

ISO (the International Organization for Standardization) is a worldwide federation of national standards bodies (ISO member bodies). The work of preparing International Standards is normally carried out through ISO technical committees. Each member body interested in a subject for which a technical committee has been established has the right to be represented on that committee. International organizations, governmental and non-governmental, in liaison with ISO, also take part in the work. ISO collaborates closely with the International Electrotechnical Commission (IEC) on all matters of electrotechnical standardization.

Draft International Standards adopted by the technical committees are circulated to the member bodies for voting. Publication as an International Standard requires approval by at least 75 % of the member bodies casting a vote.

International Standard ISO 10726 was prepared by Technical Committee ISO/TC 23, *Tractors and machinery for agriculture and forestry*, Subcommittee SC 17, *Manually portable forest machinery*.

© ISO 1992

All rights reserved. No part of this publication may be reproduced or utilized in any form or by any means, electronic or mechanical, including photocopying and microfilm, without permission in writing from the publisher.

International Organization for Standardization
Case Postale 56 • CH-1211 Genève 20 • Switzerland

Printed in Switzerland

Portable chain-saws — Chain catcher — Dimensions and mechanical strength

1 Scope

This International Standard specifies the mechanical strength and dimension requirements, and the corresponding test method for the chain catcher of chain-saws.

2 Dimensions

The chain catcher shall be positioned as far to the front of the saw body as practicable and shall extend at least 5 mm from the centre-plane of the guide-bar. See figure 1.

3 Requirements

The chain catcher itself, its mounting and the saw body shall not have any tears or cracks when tested in accordance with clause 4. The catcher shall also meet the dimensional requirement in clause 2.

NOTES

- 1 The catcher may bend during the test.
- 2 It is recognized that a chain catcher may seriously damage the saw chain upon contact. It is recommended that the chain catcher should be made of a material that will not needlessly damage the chain.

4 Test procedure

4.1 The test temperature shall be $-25\text{ °C} \pm 3\text{ °C}$, unless the chain catcher, its fastenings and the saw body are of metal, in which case the test may be conducted at room temperature.

4.2 The catcher shall be attached to the saw in a normal way. During the test the saw shall be fixed, upside down (see figure 2), by its handles.

4.3 The catcher shall be struck once with a pendulum hammer. This pendulum shall have a steel head with a flat strike face, with a width of $7\text{ mm} \pm 0,2\text{ mm}$, and an arm with a length giving $700\text{ mm} \pm 5\text{ mm}$ distance between the swivel point and the centre of the head (see figure 2). The arm shall be as light as possible. The pendulum system shall cause an impact force of $7,5\text{ J} \pm 0,3\text{ J}$ from a drop height of 300 mm. The direction and the contact of the blow shall be along the guide-bar centre-plane.

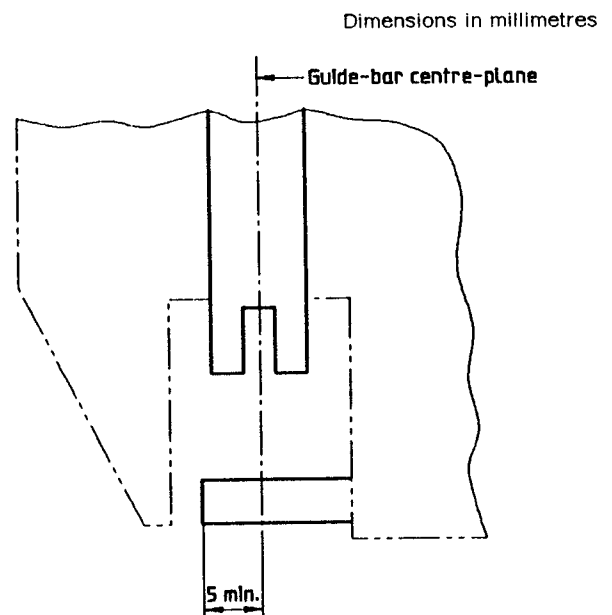

Figure 1

Dimensions in millimetres

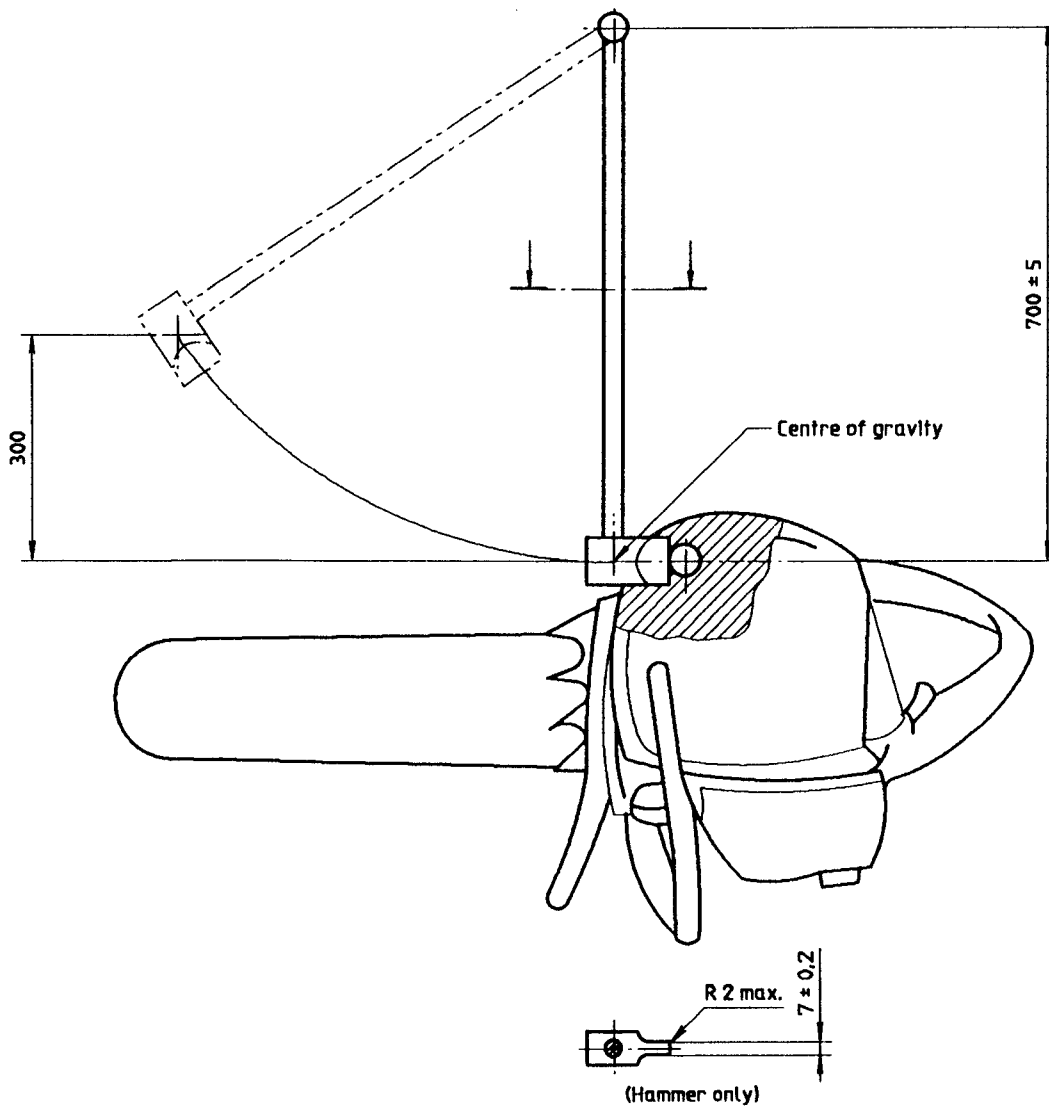

Figure 2

This page intentionally left blank

This page intentionally left blank

This page intentionally left blank

UDC 621.936.6-78:630:620.17

Descriptors: forest equipment, portable equipment, saws, chain saws, tests, impact tests, determination, strength.

Price based on 2 pages
