**Intelligent Transport Systems — Interface
Protocol and Message Set Definition
between Traffic Signal Controllers and
Detectors**

*Systèmes intelligents de transport — Protocole d'interface et définition
des ensembles de messages entre régulateurs de signaux de
circulation et détecteurs*



Reference number
ISO 10711:2012(E)

© ISO 2012



COPYRIGHT PROTECTED DOCUMENT

© ISO 2012

All rights reserved. Unless otherwise specified, no part of this publication may be reproduced or utilized in any form or by any means, electronic or mechanical, including photocopying and microfilm, without permission in writing from either ISO at the address below or ISO's member body in the country of the requester.

ISO copyright office
Case postale 56 • CH-1211 Geneva 20
Tel. + 41 22 749 01 11
Fax + 41 22 749 09 47
E-mail copyright@iso.org
Web www.iso.org

Published in Switzerland

Contents

Page

Foreword	iv
Introduction.....	v
1 Scope	1
2 Normative references	2
3 Terms and definitions	2
4 Abbreviated terms	2
5 Interface protocol for traffic controller.....	3
5.1 Relationship to other standards	3
5.2 Identification detector index	3
5.3 Detector classification	4
6 Interface messages for traffic signal controller	5
6.1 General frame structure.....	5
6.2 Detector information messages structure	7
Annex A (normative) Interface Protocol Message Set Definition between Traffic Signal Controllers and Detectors data structure and data type definition.....	16
Annex B (informative) Interface Protocol and Message Set Definition between Traffic Signal Controllers and Detectors implementation example	23
Bibliography.....	25

Foreword

ISO (the International Organization for Standardization) is a worldwide federation of national standards bodies (ISO member bodies). The work of preparing International Standards is normally carried out through ISO technical committees. Each member body interested in a subject for which a technical committee has been established has the right to be represented on that committee. International organizations, governmental and non-governmental, in liaison with ISO, also take part in the work. ISO collaborates closely with the International Electrotechnical Commission (IEC) on all matters of electrotechnical standardization.

International Standards are drafted in accordance with the rules given in the ISO/IEC Directives, Part 2.

The main task of technical committees is to prepare International Standards. Draft International Standards adopted by the technical committees are circulated to the member bodies for voting. Publication as an International Standard requires approval by at least 75 % of the member bodies casting a vote.

Attention is drawn to the possibility that some of the elements of this document may be the subject of patent rights. ISO shall not be held responsible for identifying any or all such patent rights.

ISO 10711 was prepared by Technical Committee ISO/TC 204, *Intelligent transport systems*.

Introduction

Real-time traffic signal control systems use traffic detectors to obtain traffic flow information. Each detector has its own method for collecting traffic information. Most popular is the loop detector which reports traffic data through detection of vehicle occupancy. Each method supporting different forms of detection has its own merits and disadvantages and uses a variety of message sets and protocols for communication which complicates their integration into systems.

There are two methods for integrating different types of traffic detectors. One method is to select and/or analyse the necessary information from detectors using their own message sets. The second method is to standardize the message sets and protocols to be used for the interface between detectors and traffic signal controllers. The former has the disadvantage that the signal controller must be customized each time a new detector type is introduced. The latter approach has the advantage of supporting consistent collection of traffic data without consideration of detectors' detection principles and characteristics. Thus, the second method has advantages when the use of the data is known.

This International Standard defines detector message sets applicable to traffic signal control. There are three different message sets according to the detection method: occupancy based; image processing based; and vehicle identification based. All detectors should be assigned to one of these three categories. The message sets do not contain hardware information and additional information that is not critical to the traffic signal control.

Regardless of their physical functions or manufacturing methods, all current traffic detectors can use one of the three types of message sets for communicating with traffic controllers. Using this International Standard, there is no need to include specific manufacturer's technical codes as a part of the data exchange.

This International Standard allows the signal controller to query and change the detector settings for the commonly applicable contents such as attributes identifying the installed location of the detector. For image processing based detectors, this International Standard includes minimal well-known generic camera control commands.

The encoding rules and lower layers of the OSI communications stack^[2] (e.g. transport) are left to national standards.

The benefits are

- a) all detectors can adopt one of the three types of predefined message sets, thus configuration of traffic detector system for traffic signal control becomes more simple regardless of hardware properties and manufacturing method,
- b) it is not necessary to replace or revise traffic signal controller software when a new type of detector is installed and a new detector adopting one of the three message sets will not have communications interoperability problems, as all of the necessary information items for signal control have been considered, and
- c) minimizing the communications load achieved with the compact size of predefined information; this advantage can be applicable to short range wireless communication with its weakness in the multi-channel simultaneous communication owing to hand-shaking and frequency interference.

Annex B provides an informative example of how the interface protocol and message sets are implemented.

Intelligent Transport Systems — Interface Protocol and Message Set Definition between Traffic Signal Controllers and Detectors

1 Scope

This International Standard defines protocols and message sets between traffic detectors and traffic signal controllers. It is applicable to the various types of traffic detector technologies currently in use for real-time traffic signal controls. The scope of this International Standard is limited to parameter generation to be used for traffic signal control and for the interface between traffic signal controllers and detectors.

This International Standard defines message sets that contain data collection and control protocol for three different types of detectors of traffic signal control systems:

- detectors that deal with occupancy information;
- detectors that deal with image information;
- detectors that deal with vehicle identification.

The scope of this International Standard does not include the following cases:

- interfaces between sensors [including tag or on-board units (OBU)] and detector controllers;
- interfaces between traffic signal controllers and centres;
- when signal controllers only relay data from field-side detectors to central computers;
- when signal controllers receive unencoded electrical signals from cable-connected detectors and not data from detectors.

Physical scope is limited to the communication interface between traffic signal controllers and traffic detectors. The scope does not include the interface between the traffic detector and its own controller.

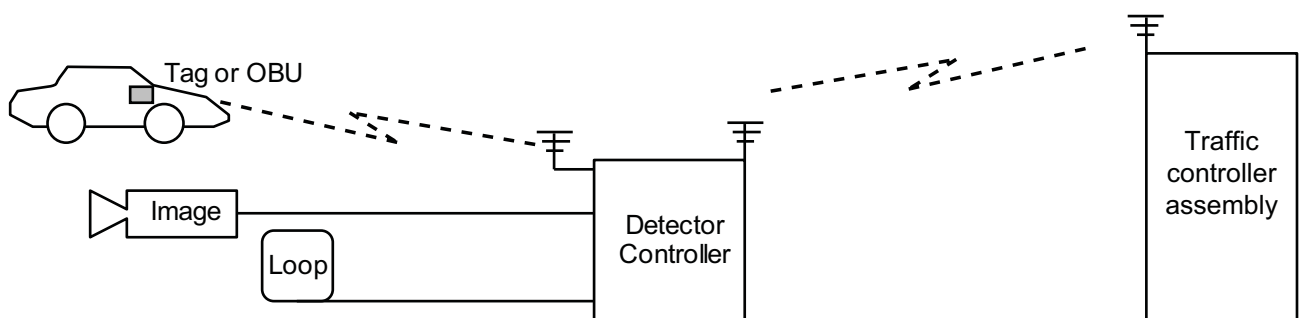

Figure 1 — Physical scope

This International Standard is limited to the definition of the message sets used to exchange detector information relevant for traffic control and the logical rules governing the exchange of these messages.

2 Normative references

The following referenced documents are indispensable for the application of this document. For dated references, only the edition cited applies. For undated references, the latest edition of the referenced document (including any amendments) applies.

ISO 15784-3:2008, *Intelligent transport systems (ITS) — Data exchange involving roadside modules communication — Part 3: Application profile-data exchange (AP-DATEX)*

ISO 14827-2:2005, *Transport information and control systems — Data interfaces between centres for transport information and control systems — Part 2: DATEX-ASN*

3 Terms and definitions

For the purposes of this document, the terms and definitions given in ISO 15784-3 and the following apply.

3.1 occupancy based detector
detector that detects vehicles and traffic characteristics based on the state of the occupancy using methods such as loop or magnetic detectors

3.2 image processing based detector
detector that detects vehicles based on the real-time image data from the digital camera which has virtual sensing lines for estimating queue length or other parameters in approaching lanes

3.3 vehicle identification based detector
detector that detects vehicle identities based on wireless communication with tags or on-board units (OBU) in the vehicle, which transmits the vehicle's identity information to the traffic signal controller

3.4 detection zone
area on the road surface where the target or the group of targets actuates the detector

NOTE Adapted from DS/ENV 13563.

3.5 detector information type
information type that designates the type of information from linked detectors which can be occupancy based, image processing based or vehicle identification based

3.6 direction discrimination
direction of travel of a target within the detection zone

NOTE Adapted from DS/ENV 13563.

4 Abbreviated terms

For the purposes of this document, the following abbreviated terms apply.

ID	Identifier
IPMSTSCD	Interface Protocol and Message Set Definition between Traffic Signal Controllers and Detectors
MIB	Management Information Base

OBU	On-Board Unit
OSI	Open System Interconnection
PDU	Protocol Data Unit
RSE	Roadside Equipment

5 Interface protocol for traffic controller

5.1 Relationship to other standards

For the interface, this International Standard defines for each application the scope of the

- 1) framework in the protocol stack,
- 2) object encoding rules, and
- 3) transportation management protocol.

The interface defined within this International Standard secures interoperability by adopting the lower layer of the protocol stack and specified standards for encoding rules, transport management rules and data structures. The criteria for detector controller and traffic signal controller define the designating method for the detectors.

The information should be exchanged according to the protocol profile defined in ISO 15784-3 and ISO 14827-2.

5.2 Identification detector index

5.2.1 Identification method

A traffic signal controller collects data from each connected detector controller using the message sets defined in this International Standard. Each detector controller reports information about its detectors, with each detector identified by a unique sequential identifier. However, since the traffic signal controller may be connected to multiple detector controllers, the traffic signal controller shall, where required, support a cross-reference table that translates the local detector identifier into an identifier that is unique for the entire scope of the traffic signal operation, as shown in Figure 2.

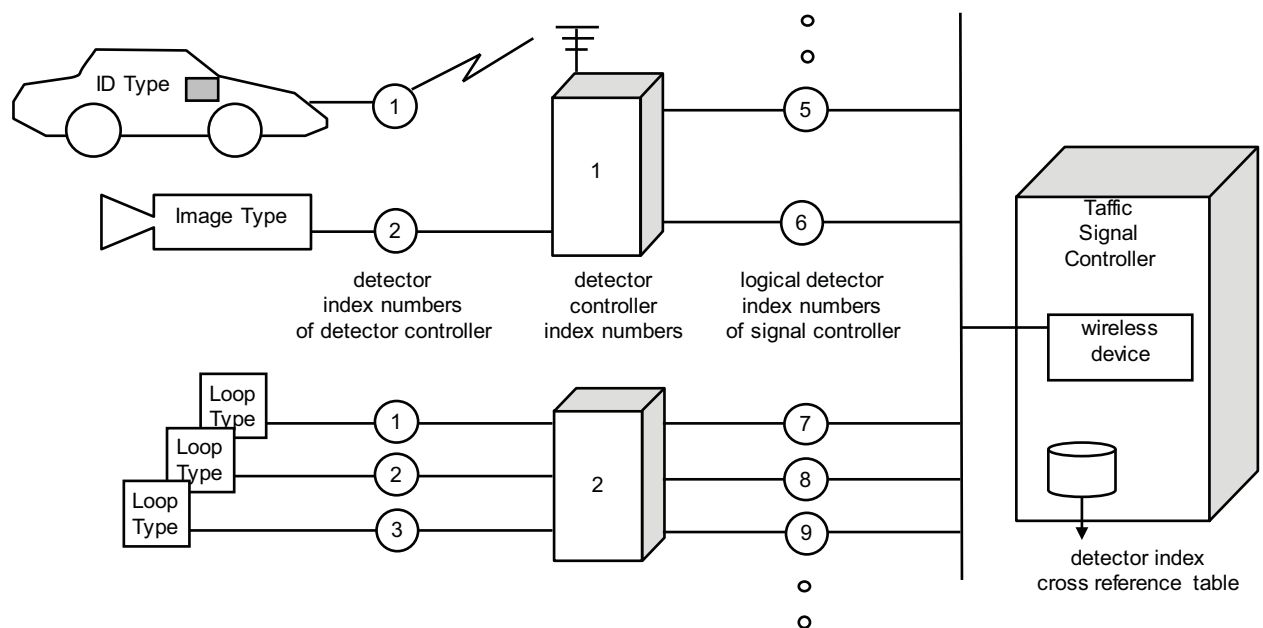

Figure 2 — Detector identification concept (example)

If and when the traffic signal controller transmits detector data to a higher level system (outside of the scope of this International Standard), it should use the derived detector ID that is unique within the full scope of the traffic signal operation.

5.2.2 Request and response

The protocol of this International Standard supports event-driven, request-response and periodic data exchange methods.

5.3 Detector classification

5.3.1 Managing multi-detector environments

The protocol supports the ability for a traffic signal controller to communicate with multiple detector controllers. In such a model, the traffic signal controller does not receive a constant analogue stream, but rather receives packets of data that managed on a cyclical basis.

5.3.2 Occupancy based detector

An occupancy based detector controller is able to report occupancy rate and vehicle speed to the traffic signal control system by determining the percent of time the sensor is detecting a vehicle. The information is used for calculating signal phases. However, if an occupancy based detector on the roadway has its own digital communication capability, then it can be regarded as a detector controller. These detector controllers are then linked sequentially with the traffic signal controller.

Any sensor that can detect vehicle presence can be used as an occupancy based detector. For example: Loop Square, Loop Rectangle, Loop Circle, Magnetic, Ultrasonic, Laser, Infra-red, Microwave.

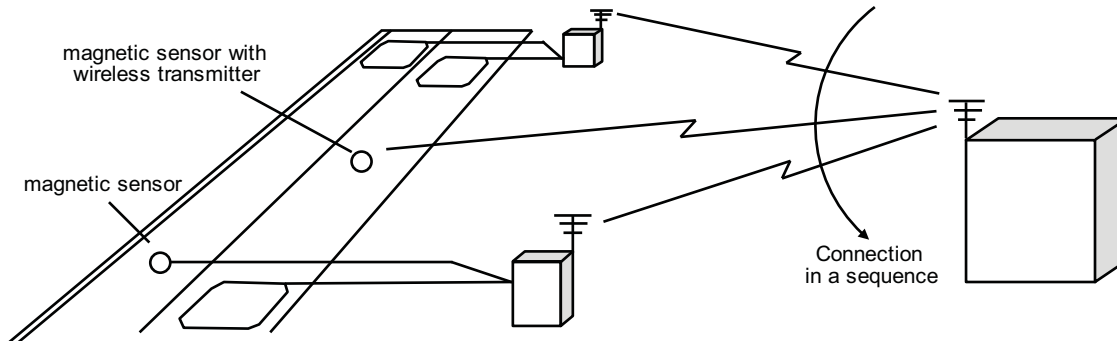

Figure 3 — Occupancy based detection concept

5.3.3 Image processing based detector

An image processing based detector controller collects camera images and reports detection information with respect to a virtual polygon detection zone in each lane. An image processing based controller has its own physical detector index, which is the same as the lane ID assigned from the median with descending (or ascending) order which is dependent upon each country's practice. Any lane without detection also has its own ID but with no information supplied.

The image processing based detector controller collects real-time camera images, detects the traffic volume with the change of images in the virtual detection zone and optionally transmits the queue length information by edge detection to traffic signal control system.

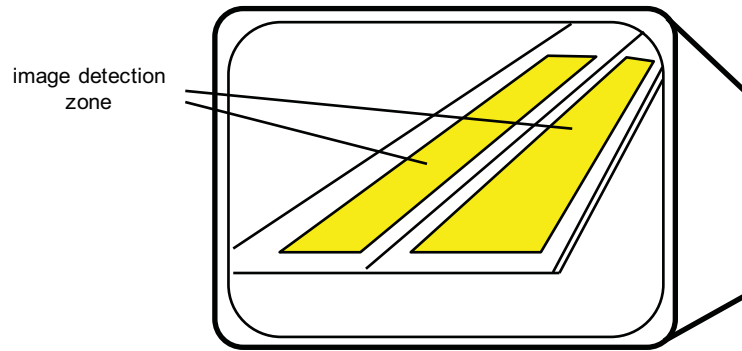

Figure 4 — Image processing based detection concept

5.3.4 Vehicle identification based detector

A vehicle identification based detector controller reports identification (ID) information for individual vehicles, identifies various vehicle properties and transmits the information to the traffic signal controller.

The vehicle identification based detector controller provides real-time vehicle ID information such as barcode, license plate, electronic tag, etc. This information can then be used by a corridor-based or area-based system to determine the real-time situation of the traffic network.

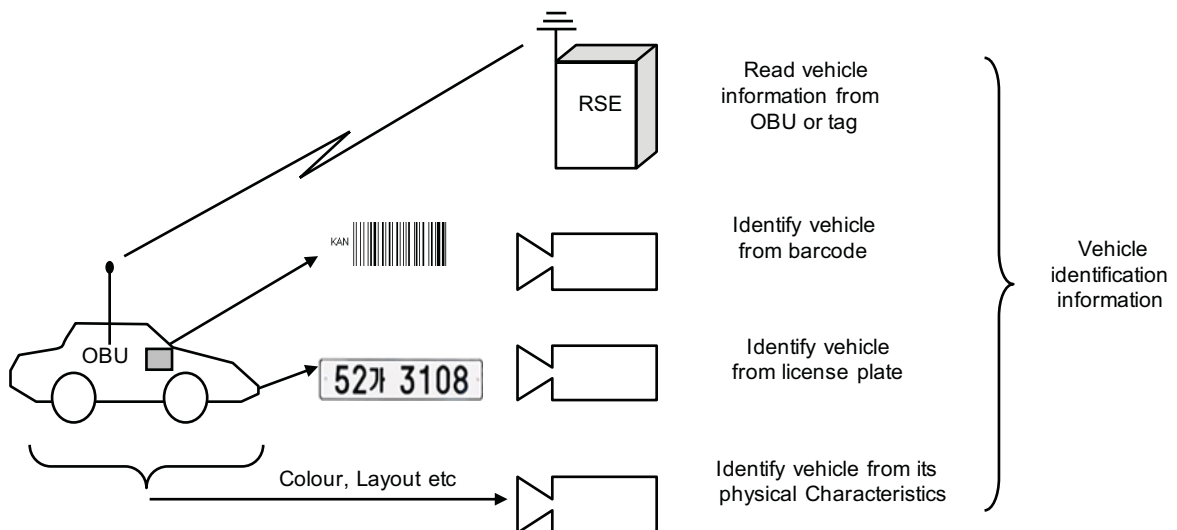

Figure 5 — Vehicle identification based detection concept

6 Interface messages for traffic signal controller

6.1 General frame structure

Messages defined in this International Standard use a structure that consists of a detector controller's information followed by information for each detector connected to that detector controller. This is depicted in Table 1. However, it is noted that interfaces defined to standards such as ISO 15784-3 do not use this structure.

Table 1 — Detector controller's information and IPMSTSCD_Data field

Detector controller's information (Optional)		IPMSTSCD_Data (Optional)		
Detector controller's index number (Mandatory)	Detector controller's time-location (Optional)	Detector information #1	...	Detector information #n

Physical detector index of detector controller (Mandatory)	Information type (Mandatory)	Detection information (Mandatory)	Detector's time-location (Optional)
--	--	---	---

6.1.1 Detector controller's information

Detector controller's information consists of two data elements: the detector controller's index number; and the detector controller's time-location. When each detector controller reports information collected from its detectors, the detector controller's information is concurrently transmitted to the traffic signal controller to identify from which controller the detector information comes.

6.1.1.1 Detector controller's index number

Detector controller's index number is the unique identification number of each detector controller (or a roadside device) connected with its sensors. As shown in Figure 2, a traffic signal controller may be connected to multiple detector controllers and, thus, in this case a unique index number is required.

6.1.1.2 Detector controller's time-location

Detector controller's time-location is a data structure supporting representation of time and location information of each detector controller (or a roadside device) as defined in ISO 14827-2. Location information is the spatial position of each detector controller. If included, the location information shall be expressed in terms of the longitude, latitude and elevation where each detector controller has been installed. Time information is the detector controller's response time when collected data is transmitted to the traffic signal controller. The data structure for the detector controller's time-location is shown in Table 2. Detector controller's time-location and detector's time-location use the time-location data structure object named GeneralTimeLocationCore.



Table 2 — Time-location data structure object (GeneralTimeLocationCore)

Item Name	Description	Reference	Need	Format
otdv_CurrentTime	Response time of detector controller or data acquisition time of each detector	ISO 14827-2	Mandatory	Time Object
otdv_LocationLongitude	Detector controller's or detector's longitude	New	Optional	INTEGER (-180000000..180000000)
otdv_LocationLatitude	Detector controller's or detector's latitude	New	Optional	
otdv_LocationElevation	Detector controller's or detector's altitude	New (Optional)	Optional	INTEGER(-8192..57344)

6.1.2 IPMSTSCD_Data

The information from a number of sensors or detectors is organized in a row oriented structure, with information from each detector containing physical detector index, information type, detection information, and detector's time-location.

6.1.2.1 Physical detector index

Detector index shall be assigned by each detector controller, as shown in Figure 2.

6.1.2.2 Information type

Information type shall use one of the following types: occupancy based, image processing based or vehicle identification based.

6.1.2.3 Detection information

The information field contains detector information (5.2). The objects for vendor oriented information collection are permitted. The object is classified by CHOICE statement.

6.1.2.4 Detector's time-location

Detector's time-location is a data structure representing the time when spot information is collected and the location where the detector sensor head is located. It uses the same Time-Location data structure as the detector controller's time-location, as shown in Table 2.

6.2 Detector information messages structure

This subclause defines the message set for information from detector controller to traffic signal controller. The message sets consist of two types with each kind of detector. One type (Type 1) is used where each detector has only one message set for sending data to a signal controller. This type is relatively simple and efficient due to the fixed structure. Another type (Type 2) is used where each detector uses one of several potential message sets for sending data to a signal controller as the specific application demands. Type 2 is able to configure the communication to support the specific application. It is noted that type 2 may not have the frame structure such as defined in 6.1; each item is sent at an appropriate time with barebones set.

6.2.1 Occupancy based detection data structure

(1) Type 1

Table 3 shows the list of message sets with type 1 occupancy based detection.

Table 3 — Occupancy based message set

Item Name	Description	Remark
loopDataDuration	Duration for collecting current data (sec)	Optional
loopOccupancyState	Current state of occupancy (BOOLEAN) (state)	Mandatory
loopOccupancyStateDuration	Current duration of occupancy (millisecond) (state)	Mandatory
loopOccupancyPreviousStateDuration	Duration of previous state of occupancy (millisecond) (state)	Mandatory
loopOccupancyRate	Occupancy rate of detection period (%) (cycle)	Mandatory
loopSpeed	Average speed of detection period (km/h) (cycle)	Optional
loopVolume	Traffic volume of detection period (number of vehicles) (cycle)	Mandatory
loopOccNocccHistory	Detected occupancy/non-occupancy list during detection (cycle)	Optional
loopErrorState	Malfunction information of occupancy based detector	Optional
loopUserData	Detector user data	Optional
loopTargetType	Classification of the Target	Optional
loopDirectionDiscrimination	Direction of the target (BOOLEAN)	Optional

Occupancy state and cycle based statistical information can be utilized according to the communication properties. State information which minimizes the data polling interval to milliseconds can be utilized. Cycle based information is utilized as a general communication within which the data polling interval is relatively long. Occupancy state (loopOccNocccHistory) is defined below. The loopVolume record designates the traffic volume.

```

IpmtscdOccNocccHistory ::= SEQUENCE {
    OccupancyTimes      INTEGER, -- msec
    NonOccupancyTimes   INTEGER -- msec
}
    
```

Error information of the detector (LoopErrorState) shown in Table 4 is encoded as follows: open loop circuit(1); short loop circuit(2); occupancy error(3); non-occupancy error(4); traffic volume error(5); parameter invalid(6); management (maintenance) required(7).

Table 4 — Occupancy based error information

Data element name	Description
OpenLoopCircuit	Open circuit of loop detector header or feeder (Open)
ShortLoopCircuit	Short circuit of detector header or feeder (Short)
OccupancyError	Minimum occupancy error (lower than predefined parameter)
NonoccupancyError	Minimum non-occupancy error (lower than predefined parameter)
VolumeError	Traffic volume error (exceeds predefined saturated traffic flow rate)
ParameterInvalid	Parameter out of range
ManagementNeeded	Error that needs maintenance

loopTargetType identifies the classification of the targets to be detected on a detector. The target types can be adequately classified and specified by standards available. For instance, a European standard, DS/ENV13563 may be referred to, in which the target type is classified into four types: pedal cycles, motor cycles, cars and goods vehicles by target length.

'loopDirectionDiscrimination' is used to discriminate the direction of travel of a target. 'TRUE' is used to represent the target approaching to an intersection and 'FALSE' is used to represent the target leaving from an intersection.

(2) Type 2

Table 5 shows the lists of message sets with type 2 occupancy based detection. It is noted that all message sets in Table 5 do not have to be implemented in detectors.

Table 5 — List of message sets for occupancy based detection

No	Message Set Name	Remark
1	Accumulative detection	Mandatory
2	Time-series of passing vehicles	Optional
3	Vehicle speed	Optional
4	Specific vehicle detection	Optional
5	Detector status	Optional

Table 6 — Accumulative detection message set

Item Name	Description	Remark
Det-nbr	Detector index number	Mandatory
Det-Status	Detection status	Optional
Density	Accumulation counter of traffic volume. This counter uses from 0 to the designated maximum value cyclically.	Mandatory
Occupancy	Accumulation counter of detection status (on-pulse) by the designated sampling. This counter uses from 0 to the designated maximum value cyclically.	Mandatory
DetPulseErr	Accumulation counter of error pulses by the designated sampling. This counter uses from 0 to the designated maximum value cyclically.	Mandatory

The message set defined in Table 6 is sent in response to a request from a signal controller. Therefore, signal controller needs to do subtraction of previous data values from the current ones for use in signal control parameter generation. It is possible to realize flexible communication as the specific application demands as each signal controller has the ability to set the interval of detector data collection.

Table 7 — Time-series of passing vehicles message set

Item Name	Description	Remark
Det-nbr	Detector index number	Mandatory
Det-Status	Detection status	Optional
SerialInfo	Each bit in the octet strings shows passage of vehicles for the designated seconds.	Mandatory

Table 8 — Vehicle speed message set

Item Name	Description	Remark
Det-nbr	Detector index number	Mandatory
VehicleType	Vehicle classification	Mandatory
Velocity	Vehicle speed (km/h)	Mandatory

Table 9 — Specific vehicle detection message set

Item Name	Description	Remark
detInfo	Detection of buses and high-speed vehicles	Mandatory

The information identified in Table 10 denotes the data element of Det-Status in Table 6, Table 7, and Table 17.

Table 10 — Detection status information

Data element name	Description
Normal	Shows normal detection
Failure	Shows detector failure
DataInvalid	Shows invalid data (for example, data just after reboot of detector)

Table 11 — Detector status message set

Item name	Description	Remark
IDetStatus	Status of processing and operating	Optional

The item (IDetStatus) in Table 11 is encoded as follows.

Table 12 — Detector status information

Data element name	Value Domain
Processing Status Flag	0: normal 1: failure
Operating Status Flag	0: normal 1: failure

6.2.2 Image processing based detection data structure

(1) Type 1

Occupancy and non-occupancy data from the virtual detector is selectively processed to integrate the information with the occupancy based detector. Among data items shown in Table 13, traffic volume is defined as a mandatory item for more flexible use. A detector which does not provide queue length may use the occupancy based message set, rather than the image processing based one.

Table 13 — Image processing based message set

Item Name	Description	Remark
imgDataDuration	Duration for collecting current data (seconds)	Optional
imgVolume_quantity	Total traffic volume of the detection lane during the detection (number of vehicles)	Mandatory
imgQueueLength_number	Queue length of the detected lane during detection (metres)	Optional
imgOccupancyRate_rate	Average occupancy rate of the detected lane during the detection (%)	Optional
imgSpeed_quantity	Average speed in the detected lane during the detection (km/h)	Optional
imgOccNoccHistory	Detected occupancy/non-occupancy list during detection { Occupancy time during lpmstscdOccupancy_quantity (second) Non-occupancy time during lpmstscdNonOccupancy_quantity (second) }	Optional
imgErrorState	No Error, Device Fail, Unstable Utility, Connection fail, Image Processing Fail, Parameter Invalid, Not Configured, Management Needed	Optional
imgUserData	Image detector user data	Optional

The data structure of historic occupancy/non-occupancy duration data in the virtual detection area (imgOccNoccHistory) is the same as the occupancy based data structure, which has a predefined number of records in the imgVolume_quantity.

Error information of the image processing based detector (imgErrorState) shown in Table 14 are encoded as follows: Device Fail(1); Unstable Utility(2); Connection Fail(3); Image Processing Fail(4); Parameter Invalid(5); Not Configured(6); Management Needed(7).

Table 14 — Image processing based error information

Data element name	Description
Device Fail(1)	Image device failure
Unstable Utility(2)	Image failure by the structure vibration and malfunction
ConnectionFail(3)	Connection failure with image processor
ImageProcessingFail(4)	Image processing failure
ParameterInvalid(5)	Parameter out of range
VolumeError(6)	No configuration data from detector controller
ManagementNeeded(7)	Error that needs maintenance

(2) Type 2

The following Table 15 shows the list of message sets with type 2 image processing based detection. It is noted that all message sets in Table 15 do not have to be implemented in detectors.

Table 15 — List of message sets for image processing detection

No	Message Set Name	Remark
1	Accumulative detection	Optional, Ref 6.2.1(2)
2	Time-series of passing vehicles	Optional, Ref 6.2.1(2)
3	Vehicle speed	Optional, Ref 6.2.1(2)
4	Specific vehicle detection	Optional, Ref 6.2.1(2)
5	Queue length and start position	Optional
6	Traffic volume by direction	Optional
7	Detector status	Optional, Ref 6.2.1(2)

Table 16 — Queue length and start position message set

Item name	Description	Remark
CongestionLength	Queue length	Mandatory
VehicleStartPosition	Vehicle start position	Mandatory

Table 17 — Traffic volume by direction message set

Item name	Description	Remark
DirectionNo	Number of direction	Mandatory
Det-Status	Detection status	Optional
DirectionDensity	Accumulations counter of traffic volume by direction. This counter uses from 0 to the designated maximum value cyclically.	Mandatory

The message set defined in Table 17 is sent in response to a request from a signal controller as well as accumulative detection (Table 6).

6.2.3 Vehicle identification based detector data structure

(1) Type 1

The following Table 18 shows the list of message sets with type 1 vehicle identification based detection. One record transmits collected information from the tag or OBU.

Table 18 — Vehicle identification based message set

Data element name	Description	Remark
idSequenceNumber	Verification sequential number for data collection	Mandatory
idDeviceType	Communication device type	Optional
idVehicleID	Vehicle ID	Mandatory
idVehicleType	Vehicle classification	Optional
idVehicleUse	Vehicle usage and property	Optional
idDetectionLane	Detection lane classification (from the curbside of the road 1-8)	Optional
idDetectionLaneMedian	Detection lane classification (from the median 1-8)	Optional
idDetectionSpeed	Vehicle speed (km/h)	Optional
idOccupancy	Occupancy duration by detector (milliseconds)	Optional
idErrorState	Error information of RSE	Optional
idTagInfo	Application information from OBU or Tag memory	Optional
idUserData	User information of vehicle identification based detector	Optional

Error information is encoded selectively in the last field of each record in case a collecting record is found to be in an error state. The idErrorState shall not be used in a record without error. Error information (idErrorState) shown in Table 19 are encoded as follows: RSE(Roadside equipment) Fail(1); RSE-Connection Fail(2); Wireless Fail(3); Unstable Utility(4); ManagementNeeded(5).

Table 19 — Vehicle identification based error information

Data element name	Description
RSEFail(1)	Malfunction of wireless communication or scanning equipment
RSE-ConnectionFail(2)	Connection failure of wireless communication equipment or scanning equipment
WirelessFail(3)	Wireless communication failure between RSE and OBU or Tag
UnstableUtility(4)	Data collection error by defective structure
ManagementNeeded(5)	Malfunction that needs manual repair

(2) Type 2

Table 20 defines the list of message sets for use with type 2 vehicle identification based detection. It is noted that all message sets in Table 20 do not have to be implemented in detectors.

Table 20 — Vehicle identification message set

No	Message Set Name	Remark
1	Accumulative detection	Optional, Ref 6.2.1(2)
2	Time-series of passing vehicles	Optional, Ref 6.2.1(2)
3	Vehicle speed	Optional, Ref 6.2.1(2)
4	Specific vehicle detection	Optional, Ref 6.2.1(2)
5	Vehicle identification	Mandatory
6	Detector status	Optional, Ref 6.2.1. (2)

Table 21 — List of message sets for vehicle identification

Item name	Description	Remark
VehicleID	Vehicle ID	Mandatory
idData	Anonymous data	Optional

Annex A (normative)

Interface Protocol Message Set Definition between Traffic Signal Controllers and Detectors data structure and data type definition

A.1 Data structure

```
IPMSTSCD DEFINITIONS IMPLICIT AUTOMATIC TAGS ::= BEGIN
-- IPMSTSCD(Interface Protocol and Message Set Definition between
-- Traffic Signal Controllers and Detectors)
-- permits automatic tagging to CHOICE and Enumerative field of the document
```

IMPORTS

```
OBJECT-TYPE FROM RFC-1212
Opaque, Counter FROM RFC1155-SMI
-- To import Time Object
Time FROM ISO14827-2
-- data format for location referencing Importing
LocationReference FROM GLOBALS
```

A.2 IPMSTSCD-Data

```
IPMSTSCD_Data ::= SEQUENCE {
    DetectorController_index          INTEGER(0..255),
    DetectorController_Time_Location  GeneralTimeLocationCore OPTIONAL
-- detector information list
    lpmstscdDetData                   SEQUENCE OF {
        -- detector index
        lpmstscdDetID                  INTEGER(0..255),
        -- detector type
        lpmstscdDetType                 ENUMERATED {
            loopTypeDetector,
            imageTypeDetector,
            idBaseTypeDetector,
            ...},
        -- data for Get/Set of detector
        lpmstscdDetInformation          CHOICE {
            loopTypeDetInf [1]          lpmstscdLoopTypeDetectorInformation,
            imageTypeDetInf [2]         lpmstscdImageTypeDetectorInformation,
```

```

        idTypeDetInfo[3]      IpmstscdIDTypeDetectorInformation
    }
    Detector_Time_Location    GeneralTimeLocationCore    OPTIONAL
} OPTIONAL
}
-- data format for basic information about Detector Controller and Detector
GeneralTimeLocationCore ::= SEQUENCE {
    otdv_CurrentTime          Time,
    otdv_LocationLongitude    INTEGER(-180000000..180000000) OPTIONAL,
    otdv_LocationLatitude     INTEGER(-90000000..90000000) OPTIONAL,
    otdv_LocationElevation    INTEGER(-8192..57344) OPTIONAL
}

```

It is noted that several message sets of type 2 may not have the frame structure such as defined in 6.1.

A.3 IpmstscdLoopTypeDetectorInformation

-- Occupancy based detector information

```

IpmstscdLoopTypeDetectorInformation ::= SEQUENCE {
    -- duration of detection data collection
    loopDataDuration          INTEGER    OPTIONAL,
    -- current state of occupancy(BOOLEAN)
    loopOccupancyState        BOOLEAN,
    -- current duration of occupancy (msec)
    loopOccupancyStateDuration    INTEGER(0..65535),
    -- duration of previous state of occupancy
    -- (if currently occupancy state, then non-occupancy) (msec)
    loopOccupancyPreviousStateDuration    INTEGER(0..65535)
    -- average occupancy rate of detection period
    loopOccupancyRate         REAL,
    -- average speed of detection period
    loopSpeed                 REAL    OPTIONAL,
    -- REAL Value conforms to ASCII string format for representing real number in ISO/IEC 8825-1
    -- (+/-##.##e+/-##), however 0.1kph unit 10 digit may be better in terms of flexibility
    loopVolume                INTEGER,
    -- occupancy/ non-occupancy pair history list of the occupancy state
    loopOccNoccHistory        SEQUENCE OF IpmstscdOccNoccHistory    OPTIONAL,
    -- error state information
    loopErrorState            ENUMERATED {
        OpenLoopCircuit(1), -- open circuit of loop detector header or Feeder (Open)
        ShortLoopCircuit(2), -- short circuit of detector header or Feeder (Short)
    }
}

```

```

OccupancyError(3),      -- minimum occupancy error
                        -- (lower than predefined parameter)
NonoccupancyError(4),  -- minimum non-occupancy error
                        -- (lower than predefined parameter)
VolumeError(5),        -- traffic volume error
                        -- (exceeds predefined saturated traffic flow rate)
ParameterInvalid(6),   -- invalid parameter
ManagementNeeded(7),   -- error that needs maintenance
} OPTIONAL,
loopUserData            OCTET STRING      OPTIONAL,
-- The classification of targets
loopTargetType          INTEGER(1..255)    OPTIONAL,
-- Direction of the target vehicle approaching to an intersection (TRUE) or leaving from an intersection
-- (FALSE).
loopDirectionDiscrimination  BOOLEAN      OPTIONAL
}

-- occupancy/ non-occupancy pair form of the occupancy state
IpmstscdOccNoccHistory ::= SEQUENCE {
    occupancyTimes          INTEGER,      --msec
    nonOccupancyTimes       INTEGER      --msec
}

```

A.4 IpmstscdOccTypeDetectorInformation - Type2

```

-- Occupancy based detector information
IpmstscdOccTypeDetectorInformation-Type2-Message DEFINITIONS ::= BEGIN

-- Accumulative Detection
Det-Accmulated ::= SEQUENCE SIZE(1..48) OF {
    Det-nbr                INTEGER(1..48),
    Det-Status              ENUMERATED { Normal(0), Fault(1), Invalid(2)}  OPTIONAL,
    Density                 INTEGER(0..65535),
    Occupancy               INTEGER(0..65535),
    DetPulseErr             INTEGER(0..65535)
}

-- Time-series of passing vehicles
Det-SerialInfo ::= SEQUENCE SIZE(1..48) OF {
    Det-nbr                INTEGER(1..48),
    Det-Status              ENUMERATED { Normal(0), Fault(1), Invalid(2)}  OPTIONAL,

```



```

SerialInfo      OCTET STRING(SIZE(8))
}
-- Vehicle speed
Det-Velocity ::= SEQUENCE SIZE(0..160) OF {
    Det-nbr      INTEGER(1..48),
    VehicleType  ENUMERATED { 4_Bus(1), 4_LargeSizeTruck(2),
                              4_SmallSizeTrack(4), 4_else(8),
                              2_LargeSizeVehicle(16), 2_else(32) },
    Velocity     INTEGER(0..127)
}

```

-- Specific vehicle detection

```
Det-Info ::= OCTET STRING(SIZE(6))
```

-- Detector status

```
IDetStatus ::= OCTET STRING(SIZE(1))  OPTIONAL
```

END

A.5 IpmstscdImageTypeDetectorInformation

--Message set for image processing based detector

```

IpmstscdImageTypeDetectorInformation ::= SEQUENCE {
    --duration for collecting current data (msec)
    imgDataDuration      INTEGER  OPTIONAL, --msec
    --queue length of the detected lane during the detection (m) mandatory
    imgQueueLength       INTEGER  OPTIONAL,
    --average occupancy rate of the detected lane during the detection (%) optional
    imgOccupancyRate     REAL     OPTIONAL,
    --average speed of the detected lane during the detection (km/h) optional
    imgSpeed              REAL     OPTIONAL,
    --total traffic volume of the detection lane during the detection time (veh)
    imgVolume             INTEGER,
    --selection from the detected occupancy/ non-occupancy time list during the detection
    imgOccNoccHistory     IpmstscdOccNoccHistory  OPTIONAL,
    imgErrorState         ENUMERATED {
        DeviceFail(1),      -- image device failure
        UnstableUtility(2), -- image failure by the structure vibration and malfunction
        ConnectionFail(3),  -- connection failure with image processor
        ImageProcessingFail(4), -- image processing failure
    }
}

```

```

    ParameterInvalid(5),      -- invalid parameter
    VolumeError(6),          -- no configuration data from detector controller
    ManagementNeeded(7),     -- error that needs maintenance
...}    OPTIONAL,
imgUserData      OCTET STRING    OPTIONAL
}

```

A.6 IpmstscdImageTypeDetectorInformation - Type2

-- Message set for image processing based detector

IpmstscdImageTypeDetectorInformation-Type2-Message DEFINITIONS ::= BEGIN

-- Accumulative detection

```

IMPORTS    Det-Accmulated, Det-SerialInfo, Det-Velocity, Det-Info, IDetStatus
          FROM IpmstscdOccTypeDetectorInformation-Type2-Message;

```

-- Queue length and start position

```

CongestionInfo ::= SEQUENCE {
    CongestionLength1    INTEGER(0..150),
    VehicleStartPosition1  INTEGER(0..150),
    CongestionLength2    INTEGER(0..150),
    VehicleStartPosition2  INTEGER(0..150)
}

```

-- Traffic volume by direction

```

DirectionDensity ::= SEQUENCE SIZE(1..32) OF {
    DirectionNo          INTEGER(1..32),
    Det-Status           ENUMERATED { Normal(0), Invalid(1) } OPTIONAL,
    DirectionDensity     INTEGER(0..65535)
}
END

```

A.7 IpmstscdIDTypeDetectorInformation

--message set of ID based detector

```

IpmstscdIDTypeDetectorInformation ::= SEQUENCE {
    -- verification sequential number for data collection (record ID number for transmission)
    idSequenceNumber     INTEGER(0..255),

```

```

-- Communication device TYPE (IR:0×10, RF:0×20, VDS: 0×30, MCD: 0×40)
idDeviceType          ENUMERATED {
    Infra-Red,
    Radio-Frequency,
    VDSs,
    Magnetics,
    BarCodeScanner,
    TagScanner,
    Other
...} OPTIONAL,
-- Vehicle ID
idVehicleIdentity     OCTET STRING,
-- Vehicle classification codes by the vehicle type or OBU
idVehicleType         INTEGER OPTIONAL,
-- Vehicle usage and property codes by the vehicle type or OBU
idVehicleUse          INTEGER OPTIONAL,
-- detection lane classification (from the curbside of the road1-8)
idDetectionLane       INTEGER(1..8) OPTIONAL,
-- detection lane classification (from the median of the road 1-8)
idDetectionLaneMedian INTEGER(1..8) OPTIONAL,
-- vehicle speed(km/h)
idDetectionSpeed      REAL    OPTIONAL,
-- occupancy duration by detector(ms)
idOccupancy           INTEGER OPTIONAL,
-- malfunction code for this record
idErrorState          ENUMERATED {
    RSEFail(1)          -- malfunction of wireless communication or scanning equipment
    RSE-Connection Fail(2) -- connection failure of wireless communication equipment or scanning
equipment
    WirelessFail(3)     -- wireless communication failure
    UnstableUtility(4)  -- data collection error by defective structure
    ManagementNeeded(5) -- malfunction that needs manual repair
} OPTIONAL,
-- Tag identification data from the OBU of the vehicle(tag data block)
idTagInfo             OCTET STRING    OPTIONAL,
idUserData             OCTET STRING    OPTIONAL
}

```

A.8 IpmstscdIDTypeDetectorInformation - Type2

-- message set of ID based detector

IpmstscdIDTypeDetectorInformation-Type2-Message DEFINITIONS ::= BEGIN

-- Accumulative detection

IMPORTS Det-Accmulated, Det-SerialInfo, Det-Velocity, Det-Info, IDetStatus
FROM IpmstscdOccTypeDetectorInformation-Type2-Message;

-- Vehicle identification

VehicleInfo ::= SEQUENCE OF{
 VehicleID OCTET STRING,
 idData OCTET STRING OPTIONAL
}

END

Annex B (informative)

Interface Protocol and Message Set Definition between Traffic Signal Controllers and Detectors implementation example

This example shows how the traffic signal controller and the detector controller interface with this International Standard.

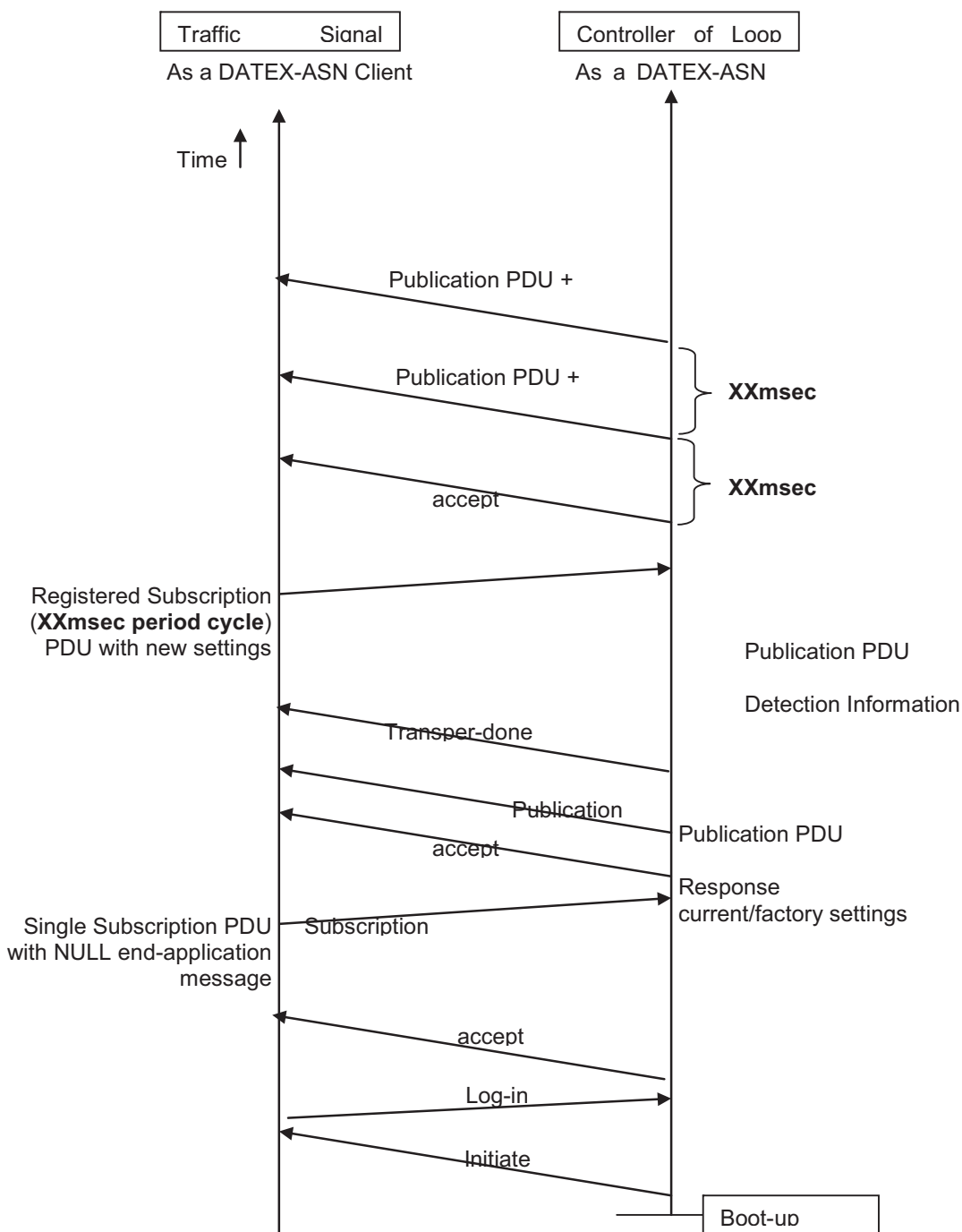

Table B.1 shows an example of the implementation of “SerialInfo” given in Table 7.

Table B.1 — An example of SerialInfo

Item Name	Description								
SerialInfo	Each bit (t_n) in 8 octet strings shows passage of vehicles for 60 seconds as follows. n denotes the elapsed seconds when detector start setting it in these octets.								
		bit7	bit6	bit5	bit4	bit3	bit2	bit1	bit0
	1 st Octet	t7	t6	t5	t4	t3	t2	t1	t0
	2 nd Octet	t15	t14	t13	t12	t11	t10	t9	t8
	3 rd Octet	t23	t22	t21	t20	t19	t18	t17	t16
	4 th Octet	t31	t30	t29	t28	t27	t26	t25	t24
	5 th Octet	t39	t38	t37	t36	t35	t34	t33	t32
	6 th Octet	t47	t46	t45	t44	t43	t42	t41	t40
	7 th Octet	t55	t54	t53	t52	t51	t50	t49	t48
	8 th Octet	*	*	*	*	t59	t58	t57	t56
* denotes a reserved bit.									

Bibliography

- [1] ISO/IEC 8825-1, *Information technology — ASN.1 encoding rules: Specification of Basic Encoding Rules (BER), Canonical Encoding Rules (CER) and Distinguished Encoding Rules (DER)*
- [2] ISO/IEC TR 10000-2:1998, *Information technology — Framework and taxonomy of International Standardized Profiles — Part 2: Principles and Taxonomy for OSI Profiles*
- [3] DS/ENV 13563, *Traffic control equipment — Vehicle detectors*

.....

ICS 03.220.01; 35.240.60

Price based on 25 pages