

# INTERNATIONAL STANDARD

# ISO 10669

First edition  
1999-08-01

---

---

## Plain washers for tapping screw and washer assemblies — Normal and large series — Product grade A

*Rondelles plates pour vis à tôle à rondelle incorporée — Séries normale  
et large — Grade A*



Reference number  
ISO 10669:1999(E)

## **Foreword**

ISO (the International Organization for Standardization) is a worldwide federation of national standards bodies (ISO member bodies). The work of preparing International Standards is normally carried out through ISO technical committees. Each member body interested in a subject for which a technical committee has been established has the right to be represented on that committee. International organizations, governmental and non-governmental, in liaison with ISO, also take part in the work. ISO collaborates closely with the International Electrotechnical Commission (IEC) on all matters of electrotechnical standardization.

International Standards are drafted in accordance with the rules given in the ISO/IEC Directives, Part 3.

Draft International Standards adopted by the technical committees are circulated to the member bodies for voting. Publication as an International Standard requires approval by at least 75 % of the member bodies casting a vote.

International Standard ISO 10669 was prepared by Technical Committee ISO/TC 2, *Fasteners*.

© ISO 1999

All rights reserved. Unless otherwise specified, no part of this publication may be reproduced or utilized in any form or by any means, electronic or mechanical, including photocopying and microfilm, without permission in writing from the publisher.

International Organization for Standardization  
Case postale 56 • CH-1211 Genève 20 • Switzerland  
Internet iso@iso.ch

Printed in Switzerland

# Plain washers for tapping screw and washer assemblies — Normal and large series — Product grade A

## 1 Scope

This International Standard specifies the characteristics of plain steel washers of product grade A for tapping screw and washer assemblies in accordance with ISO 10510.

## 2 Normative references

The following normative documents contain provisions which, through reference in this text, constitute provisions of this International Standard. For dated references, subsequent amendments to, or revisions of, any of these publications do not apply. However, parties to agreements based on this International Standard are encouraged to investigate the possibility of applying the most recent editions of the normative documents indicated below. For undated references, the latest edition of the normative document referred to applies. Members of ISO and IEC maintain registers of currently valid International Standards.

ISO 3269:—<sup>1)</sup>, *Fasteners — Acceptance inspection*.

ISO 4042:1999, *Fasteners — Electroplated coatings*.

ISO 4759-3:—<sup>2)</sup>, *Tolerances for fasteners — Part 3: Plain washers for bolts, screws and nuts — Product grades A and C*.

ISO 6507-1:1997, *Metallic materials — Vickers hardness test — Part 1: Test method*.

ISO 10510:1999, *Tapping screw and washer assemblies with plain washers*.

---

<sup>1)</sup> To be published. (Revision of ISO 3269:1988)

<sup>2)</sup> To be published. (Revision of ISO 4759-3:1991)

### 3 Classification

Washers of product grade A for tapping screw and washer assemblies are classified into two types:

- Type N: Normal series;
- Type L: Large series.

### 4 Dimensions

#### 4.1 Type N, normal series

See Figure 1 and Table 1.

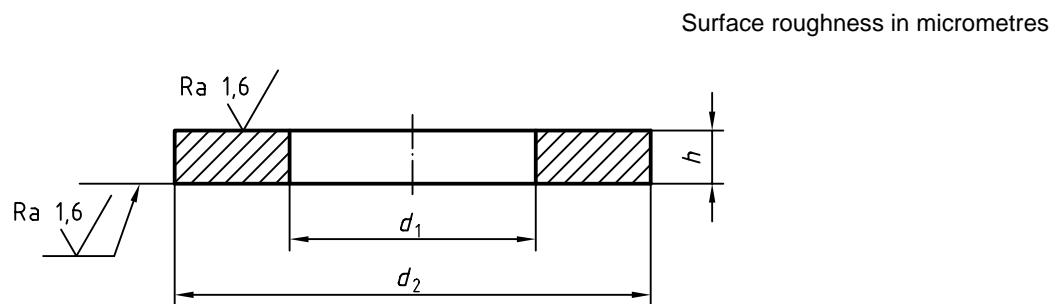

Figure 1

Table 1

Dimensions in millimetres

Nominal size (Nominal thread diameter, $d$ )	Clearance hole		Outside diameter		Thickness		
	nom. (min.)	$d_1$ max.	nom. (max.)	$d_2$ min.	nom.	$h$ max.	min.
2,2	1,9	2	5	4,82	1	1,06	0,94
2,9	2,5	2,6	7	6,64	1	1,06	0,94
3,5	3	3,1	8	7,64	1	1,06	0,94
4,2	3,55	3,67	9	8,64	1	1,06	0,94
4,8	4	4,12	10	9,64	1	1,06	0,94
5,5	4,7	4,82	12	11,57	1,6	1,68	1,52
6,3	5,4	5,52	14	13,57	1,6	1,68	1,52
8	7,15	7,3	16	15,57	1,6	1,68	1,52
9,5	8,8	8,95	20	19,48	2	2,09	1,91

## 4.2 Type L, large series

See Figure 2 and Table 2.

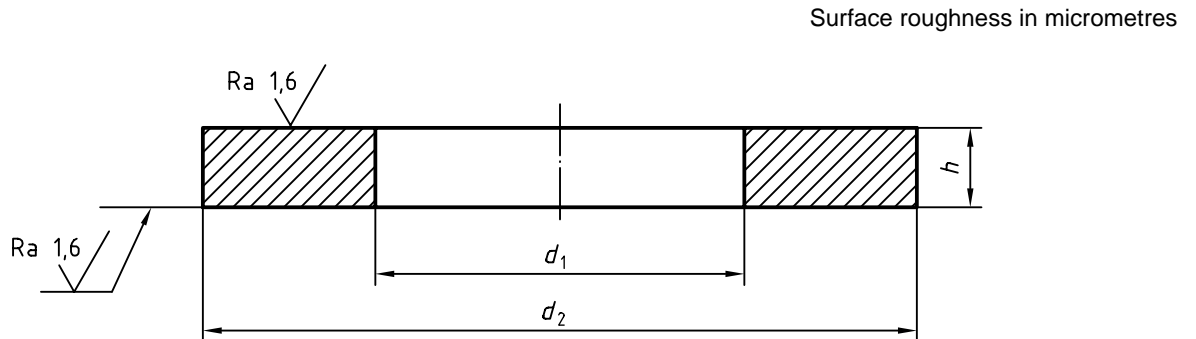

**Figure 2**

**Table 2**

Dimensions in millimetres

Nominal size (Nominal thread diameter, $d$ )	Clearance hole		Outside diameter		Thickness		
	nom. (min.)	max.	nom. (max.)	min.	nom.	max.	min.
2,2	1,9	2	7	6,64	1	1,06	0,94
2,9	2,5	2,6	9	8,64	1	1,06	0,94
3,5	3	3,1	11	10,57	1	1,06	0,94
4,2	3,55	3,67	12	11,57	1	1,06	0,94
4,8	4	4,12	15	14,57	1,6	1,68	1,52
5,5	4,7	4,82	15	14,57	1,6	1,68	1,52
6,3	5,4	5,52	18	17,57	1,6	1,68	1,52
8	7,15	7,3	24	23,48	2	2,09	1,91
9,5	8,8	8,95	30	29,48	2,5	2,59	2,41

## 5 Specifications and reference International Standards

See Table 3.

Table 3

<b>Material<sup>a</sup></b>		Steel <sup>b</sup>
<b>Mechanical properties<sup>c</sup></b>	Hardness class	180 HV
	Hardness range <sup>d</sup>	180 HV to 300 HV
<b>Tolerances</b>	Product grade	A <sup>e</sup>
	International Standard	ISO 4759-3
<b>Surface finish</b>	<p>Plain, i.e. washers to be supplied in natural finish, treated with a protective lubricant or with other coatings as agreed between customer and supplier.</p> <p>Requirements for electroplating are covered in ISO 4042.</p> <p>All tolerances shall apply prior to the application of a plating or coating.</p>	
<b>Workmanship</b>	Parts shall be free of irregularities or detrimental defects. No protruding burrs shall appear on the washer.	
<b>Acceptability</b>	For the acceptance procedure see ISO 3269.	
<p><sup>a</sup> Other materials as agreed between customer and supplier.</p> <p><sup>b</sup> The carbon content shall not exceed 0,12 %.</p> <p><sup>c</sup> The mechanical properties are for the as delivered condition only. They may change when the screw and washer assembly is hardened and tempered.</p> <p><sup>d</sup> Hardness testing according to ISO 6507-1.</p> <p>Test force:</p> <p>HV 10 for nominal thickness <math>h \leq 1,2</math> mm</p> <p>HV 30 for nominal thickness <math>h &gt; 1,2</math> mm</p> <p><sup>e</sup> Product grade A does not apply to the tolerance of the clearance hole <math>d_1</math> and the thickness <math>h</math>.</p>		

## 6 Designation

**EXAMPLE** A plain steel washer for tapping screw and washer assemblies, normal series, of nominal size 4,2 mm and hardness class 180 HV is designated as follows:

**Washer ISO 10669 - N - 4,2 - 180 HV**



---

---

**ICS 21.060.30**

Price based on 4 pages

---

---