

# INTERNATIONAL STANDARD

# ISO 10651-4

First edition  
2002-03-01

---

---

## Lung ventilators —

### Part 4: Particular requirements for operator- powered resuscitators

*Ventilateurs pulmonaires —*

*Partie 4 : Exigences relatives aux ressuscitateurs à puissance motrice manuelle*



Reference number  
ISO 10651-4:2002(E)

© ISO 2002

**PDF disclaimer**

This PDF file may contain embedded typefaces. In accordance with Adobe's licensing policy, this file may be printed or viewed but shall not be edited unless the typefaces which are embedded are licensed to and installed on the computer performing the editing. In downloading this file, parties accept therein the responsibility of not infringing Adobe's licensing policy. The ISO Central Secretariat accepts no liability in this area.

Adobe is a trademark of Adobe Systems Incorporated.

Details of the software products used to create this PDF file can be found in the General Info relative to the file; the PDF-creation parameters were optimized for printing. Every care has been taken to ensure that the file is suitable for use by ISO member bodies. In the unlikely event that a problem relating to it is found, please inform the Central Secretariat at the address given below.

© ISO 2002

All rights reserved. Unless otherwise specified, no part of this publication may be reproduced or utilized in any form or by any means, electronic or mechanical, including photocopying and microfilm, without permission in writing from either ISO at the address below or ISO's member body in the country of the requester.

ISO copyright office  
Case postale 56 • CH-1211 Geneva 20  
Tel. + 41 22 749 01 11  
Fax + 41 22 749 09 47  
E-mail [copyright@iso.ch](mailto:copyright@iso.ch)  
Web [www.iso.ch](http://www.iso.ch)

Printed in Switzerland

## Foreword

ISO (the International Organization for Standardization) is a worldwide federation of national standards bodies (ISO member bodies). The work of preparing International Standards is normally carried out through ISO technical committees. Each member body interested in a subject for which a technical committee has been established has the right to be represented on that committee. International organizations, governmental and non-governmental, in liaison with ISO, also take part in the work. ISO collaborates closely with the International Electrotechnical Commission (IEC) on all matters of electrotechnical standardization.

International Standards are drafted in accordance with the rules given in the ISO/IEC Directives, Part 3.

The main task of technical committees is to prepare International Standards. Draft International Standards adopted by the technical committees are circulated to the member bodies for voting. Publication as an International Standard requires approval by at least 75 % of the member bodies casting a vote.

Attention is drawn to the possibility that some of the elements of this part of ISO 10651 may be the subject of patent rights. ISO shall not be held responsible for identifying any or all such patent rights.

ISO 10651-4 was prepared by the European Committee for Standardization (CEN) in collaboration with Technical Committee ISO/TC 121, *Anaesthetic and respiratory equipment*, Subcommittee SC 3, *Lung ventilators and related equipment*, in accordance with the Agreement on technical cooperation between ISO and CEN (Vienna Agreement).

Throughout the text of this document, read "...this European Standard..." to mean "...this International Standard...".

ISO 10651 consists of the following parts, under the general title *Lung ventilators*:

- *Part 1: Requirements*
- *Part 2: Particular requirements for home care ventilators*
- *Part 3: Particular requirements for emergency and transport ventilators*
- *Part 4: Particular requirements for operator-powered resuscitators*

Annex A forms a normative part of this part of ISO 10651. Annex B is for information only.

For the purposes of this part of ISO 10651, the CEN annex regarding fulfilment of European Council Directives has been removed.

## Contents

	Page
Foreword.....	v
1 Scope .....	1
2 Normative references .....	1
3 Terms and definitions.....	1
4 Connectors .....	3
5 Operational requirements .....	3
6 Ventilatory requirements.....	4
7 Storage and operating conditions.....	6
8 Requirements for resuscitator, or parts, supplied sterile .....	6
9 Marking .....	6
10 Information to be provided by the manufacturer in operating and maintenance instructions .....	7
Annex A (normative) Test methods.....	9
Annex B (informative) Rationale .....	19
Bibliography .....	22

## Foreword

This document (EN ISO 10651-4:2002) has been prepared by Technical Committee CEN/TC 215 "Respiratory and anaesthetic equipment", the secretariat of which is held by BSI, in collaboration with Technical Committee ISO/TC 121 "Anaesthetic and respiratory equipment".

This European Standard shall be given the status of a national standard, either by publication of an identical text or by endorsement, at the latest by September 2002, and conflicting national standards shall be withdrawn at the latest by September 2002.

This document has been prepared under a mandate given to CEN by the European Commission and the European Free Trade Association, and supports essential requirements of EU Directive(s).

Annex A is normative and form part of this European Standard.

Annex B is for information only.

According to the CEN/CENELEC Internal Regulations, the national standards organizations of the following countries are bound to implement this European Standard : Austria, Belgium, Czech Republic, Denmark, Finland, France, Germany, Greece, Iceland, Ireland, Italy, Luxembourg, Malta, Netherlands, Norway, Portugal, Spain, Sweden, Switzerland and the United Kingdom.



## 1 Scope

This European Standard specifies requirements for operator-powered resuscitators intended for use with all age groups and which are portable and intended to provide lung ventilation to individuals whose breathing is inadequate. Operator-powered resuscitators for infants and children are designated according to body mass range and approximate age equivalent.

Electrically- and gas-powered resuscitators are not covered by this European Standard.

NOTE Annex B contains rationale statements for this Part of this European Standard. The clauses and subclauses which have corresponding rationale statements are marked with **R** after their number.

## 2 Normative references

This European Standard incorporates by dated or undated reference, provisions from other publications. These normative references are cited at the appropriate places in text and the publications are listed hereafter. For dated references, subsequent amendments to or revisions of any of these publications apply to this European Standard only when incorporated in it by amendment or revision. For undated references the latest edition of the publication referred to applies (including amendments).

EN 148-1, *Respiratory protective devices - Threads for facepieces –Part 1: Standard thread connection.*

EN 556: 1994+A1:1998, *Sterilization of medical devices - Requirements for terminally-sterilized medical devices to be labelled "STERILE".*

EN 737-1, *Medical gas pipeline systems - Part 1: Terminal units for compressed medical gases and vacuum.*

EN 868-1, *Packaging materials and systems for medical devices which are to be sterilized - Part 1: General requirements and test methods .*

EN 1041, *Information supplied by the manufacturer with medical devices.*

EN 1281-1, *Anaesthetic and respiratory equipment - Conical connectors - Part 1: Cones and sockets.*

prEN 13544-2:2000, *Respiratory therapy equipment – Part 2 : Specifications for tubing and connectors.*

EN ISO 4135:1996, *Anaesthesiology – Vocabulary (ISO 4135 :1995).*

## 3 Terms and definitions

For the purposes of this part of EN ISO 10651, the terms and definitions given in EN ISO 4135:1996 and the following terms and definitions apply.

NOTE Some of the definitions have been taken from EN ISO 4135, but they are included in this European Standard for convenience; other definitions, which are given in EN ISO 4135, for apparatus in general, have been modified slightly for the purposes of this European Standard as they apply specifically to resuscitators.

### 3.1

#### **reverse leakage**

volume of expired gas which does not pass through the expiratory port but returns to the resuscitator

### 3.2

#### **bag inlet valve**

valve activated by the subatmospheric pressure in the compressible unit of the resuscitator to refill the compressible unit with gas at ambient pressure

### 3.3

#### **bag refill valve**

valve, with no manual trigger, activated by the sub-atmospheric pressure in the compressible unit of the resuscitator to refill the compressible unit from a pressurized gas source

## ISO 10651-4:2002(E)

### 3.4

#### **compressible unit**

that part of an operator-powered resuscitator e.g. a bag or bellows that, when compressed by the operator, delivers a volume of gas

### 3.5

#### **delivered oxygen concentration**

average concentration of oxygen in the gas delivered from the resuscitator

### 3.6

#### **delivered volume, $V_{del}$**

volume of gas, expressed in millilitres, leaving the resuscitator through the patient connection port during the inspiratory phase

### 3.7

#### **forward leakage**

volume of gas produced by the resuscitator during the inspiratory phase which does not pass through the patient port to the patient but passes to the atmosphere

### 3.8

#### **minute volume, $\dot{V}$**

volume of gas per minute entering or leaving the patient's lungs

### 3.9

#### **operator-powered resuscitator**

resuscitation device in which ventilation of the lungs is produced by the operator compressing the compressible unit of the device

NOTE Hereinafter called "resuscitator".

### 3.10

#### **patient connection port**

that opening through which gas flows to and from the patient

### 3.11

#### **patient connection port connector**

connector at the patient connection port which connects directly to a face mask or an appropriate mating airway device

### 3.12

#### **patient valve**

valve in the breathing system that directs gas into the lungs for the inspiratory phase and into the atmosphere during the expiratory phase

### 3.13

#### **pressure limiting system**

means for limiting the maximum delivery pressure

### 3.14

#### **resuscitator deadspace, $V_{D,app}$**

that volume of previously exhaled gas which is delivered from the resuscitator in the succeeding inspiratory phase

### 3.15

#### **tidal volume, $V_T$**

volume of gas, expressed in millilitres, entering or leaving the patient or the lung model during the inspiratory or expiratory phase

### 3.16

#### **ventilatory cycle**

ventilation cycle comprising the inspiratory phase plus the expiratory phase of breathing



## 4 Connectors

### 4.1 Patient connection port connector

The patient connection port connector of the resuscitator shall be a 15 mm female and 22 mm male coaxial connector complying with EN 1281-1.

### 4.2 R) Expiratory port connector for breathing gases

If an expiratory port connector is provided, it shall be one of the following :

- a) a 30 mm male conical connector complying with EN 1281-1 or ;
- b) a permanent connection or proprietary connector incompatible with EN 1281-1 and EN 737-1 ;

and with a means to prevent connection with internal lumen to any breathing attachment.

### 4.3 Face mask connectors

If provided with the resuscitator, face masks shall have either a 22 mm female connector or a 15 mm male connector which shall mate with the corresponding connectors specified in EN 1281-1.

### 4.4 R) Bag refill valve connectors

If a conical connector is provided for attachment of a bag refill valve, it shall be a unique 32 mm female design. The dimensions of this connector, when submitted to the test gauge given in Figure A.1, shall fit within the tolerance steps.

### 4.5 Bag inlet valve connectors

Bag inlet valve connectors shall not be compatible with connectors dimensioned in accordance with EN 1281-1. The bag inlet valve should be designed to minimize the risk of unintentional connection of breathing attachments which might block the valve

### 4.6 Threaded gas filter connectors

If the resuscitator is fitted with a threaded gas filter connection, it shall comply with EN 148-1.

### 4.7 Oxygen tube connector and pressure gauge connector

The oxygen tube connector, if provided, shall comply with prEN 13544-2:2000. The pressure gauge connector (if provided) shall not be compatible with tubing fitting the oxygen tube connector.

## 5 Operational requirements

### 5.1 General

All test performance requirements in this European Standard shall be satisfied when the resuscitator is operated by one person.

### 5.2 R) Dismantling and reassembly

A resuscitator intended to be dismantled by the user, e.g. for cleaning, etc. should be designed so as to minimize the risk of incorrect reassembly when all parts are mated.

The manufacturer shall recommend a functional test of operation to be carried out after reassembly (see 10.2d).

### 5.3 R) Patient valve function after contamination with vomitus

After the resuscitator has been tested in accordance with the test described in A.4.3, it shall meet the requirements specified in 6.2, 6.4, 6.7.1 and 6.7.2.

NOTE It is preferable that the valve housing be constructed so that operation of the mechanism can be observed by the operator, e.g. through a transparent housing. Observation of the functioning mechanism of the patient valve can assist the operator in detecting abnormal operation.

### 5.4 Mechanical shock

#### 5.4.1 R) Drop test

The resuscitator shall meet, at room temperature, the requirements specified in 6.2, 6.4 and 6.7.1, following the drop test described in A.4.4.

### 5.5 Immersion in water

After immersion in water by the method described in A.4.5, the resuscitator shall comply with the requirements specified in 6.2, 6.4, 6.7.1 and 6.7.2.

### 5.6 R) Bag refill valves

Bag refill valves for use with resuscitators shall not have provision for manual operation.

### 5.7 Materials of construction

All gas conducting parts shall be from materials selected to take into account the chemical and physical properties of any substances that the manufacturer declares can be administered by the resuscitator

## 6 Ventilatory requirements

### 6.1 R) Supplementary oxygen and delivered oxygen concentration

When tested by the method described in A.4.6 in accordance with the requirements of its classification (see 6.7.1) a resuscitator shall provide a minimum delivered oxygen concentration of at least 35 % (V/V) when connected to an oxygen source supplying not more than 15 l/min and, in addition, shall be capable of providing an oxygen concentration of at least 85 % (V/V) (see note). The manufacturer shall state the range of delivered oxygen concentrations at representative flows, i.e. 2 l/min, 4 l/min, 6 l/min, 8 l/min, etc.

NOTE The 85 % (V/V) requirement can be accomplished with the use of an attachment.

### 6.2 R) Expiratory resistance

In the absence of positive end-expiratory pressure devices, and when tested by the method described in A.4.7, the pressure generated at the patient connection port shall not exceed 0,5 kPa ( $\approx 5$  cmH<sub>2</sub>O). (See also 10.2 c) 8)).

### 6.3 R) Inspiratory resistance

When tested by the method described in A.4.8, the pressure at the patient connection port shall not exceed 0,5 kPa ( $\approx 5$  cmH<sub>2</sub>O) below atmospheric pressure. (See also 10.2 c) 8)).

### 6.4 R) Patient valve malfunction

When tested by the method described in A.4.9, an inadvertent positive expiratory pressure greater than 0,6 kPa ( $\approx 6$  cmH<sub>2</sub>O) shall not be created at an added input flow of up to 30 l/min when this flow is added in accordance with the manufacturer's instructions.

## 6.5 R) Patient valve leakage - Forward leakage

If forward leakage is a design feature, it shall be so stated in the instruction manual.

## 6.6 R) Resuscitator deadspace and rebreathing

When tested by the method described in A.4.10, the resuscitator deadspace shall not exceed 5 ml + 10 % of the minimal delivered volume specified for the classification of the resuscitator (see 6.7.1).

Excessive rebreathing should not occur during spontaneous breathing.

## 6.7 R) Ventilation performance

### 6.7.1 R) Minimum delivered volume ( $V_{del}$ )

When tested as described in A.4.11 using the compliance, resistance, frequency and I:E ratio given in Table 1, the minimum delivered volume shall be as given in Table 1.

### 6.7.2 R) Pressure limitation

**6.7.2.1** For resuscitators designated for use with a body mass less than 10 kg, a pressure-limiting system shall be provided so that the airway pressure does not exceed 4,5 kPa ( $\approx 45$  cmH<sub>2</sub>O) under the test conditions described in A.4.12. However, it shall be possible to generate an airway pressure of at least 3 kPa ( $\approx 30$  cm H<sub>2</sub>O).

NOTE An override mechanism can be provided.

**6.7.2.2** If a pressure-limiting system is provided for a resuscitator designated for use with patients of over 10 kg body mass, the pressure at which it operates shall be stated in the instruction manual [see 10.2 c)9)]. Any pressure-limiting device provided that limits pressure to below 6 kPa ( $\approx 60$  cmH<sub>2</sub>O) shall be equipped with an override mechanism. If provided with a locking mechanism, pressure override mechanisms shall be so designed that the operating mode, i.e. on or off, is readily apparent to the user by obvious control position, flag, etc.

Compliance is tested by visual inspection.

Table 1 — Test conditions for ventilatory performance

Patient Body mass B <sup>a</sup>	Compliance	Resistance	Inspiration: Expiration ratio	Frequency <i>f</i> Breaths/min	Minimum delivered volume <i>V</i> <sub>Del</sub>
Kg	l/kPa	kPa/(l/s)	± 20 %	± 10 %	ml
B ≤ 5	0,01	40	1:1	60	20
5 < B ≤ 10	0,1	2	1:2	25	150
10 < B ≤ 40	0,2	2	1:2	20	15 × B <sup>1)</sup>
B > 40	0,2	2	1:2	20	600

<sup>a</sup> B = Body mass, in kilograms, designated by the manufacturer in the manual.

## 7 Storage and operating conditions

### 7.1 Storage

The resuscitator and the resuscitator kit (if provided) shall, after storage at temperatures of - 40 °C and + 60 °C and at any relative humidity between 40 % r.h. and 95 % r.h., comply with clause 6 except 6.6 (dead-space).

### 7.2 R) Operating conditions

When tested by the method described in A.4.13, the resuscitator shall comply with clause 6 throughout the range of relative humidity from 15 % r.h. to 95 % r.h either :

- throughout the temperature range from - 18 °C to + 50 °C ; or
- if a specific operating range is given (see 9.2 and 10) throughout the temperature range declared by the manufacturer.

## 8 Requirements for resuscitator, or parts, supplied sterile

### 8.1 Sterility assurance

Resuscitators or parts supplied and marked as “STERILE” shall satisfy requirement 4.1 of EN 556:1994+A1:1998 for the assurance of sterility needed to make the claim of being sterile.

### 8.2 Packaging for resuscitators or parts supplied sterile

The packaging shall serve as an effective barrier to the penetration of micro-organisms and particulate material in accordance with EN 868-1.

The packaging shall not be capable of reclosure without clearly revealing that it has been opened.

## 9 Marking

### 9.1 General

Marking of resuscitators, or parts if applicable, packages, inserts and information to be supplied by the manufacturer shall comply with EN 1041.

NOTE Some requirements of 9 can be met by the use of appropriate symbols as given in EN 980.

## 9.2 Indication of operating conditions

If the resuscitator cannot function as specified in 7.2 between - 18 °C and + 50 °C, a warning shall be marked on the device.

NOTE Examples of warnings are :

— “only for use between .... °C and .... °C ; or a symbol as shown in Figure 1.

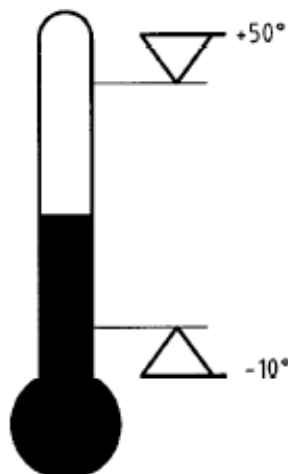

Figure 1 — Example of symbol for showing operation condition between - 10 °C and + 50 °C

## 9.3 Indication of pressure-limiting system setting

If the resuscitator is supplied with a pressure-limiting system set at one fixed pressure, the nominal pressure setting at which the system is activated shall be marked on the resuscitator.

## 10 Information to be provided by the manufacturer in operating and maintenance instructions

### 10.1 General

The manufacturer shall provide instructions for use and maintenance. The size and shape of these instructions for use should be such that they can be enclosed with or attached to the resuscitator container.

### 10.2 Contents

In addition of EN 1041 the instructions for use and maintenance shall include the following information, where applicable :

- a) a warning to the effect that incorrect operation of the resuscitator can be hazardous ;
- b) instructions on how to make the resuscitator operational in all intended modes of operation ;
- c) a specification detailing the following information for the resuscitator and its recommended accessories if applicable :

## ISO 10651-4:2002(E)

- 1) the body mass range for which the resuscitator is suitable for use ;
  - 2) operating environmental limits ;
  - 3) storage environmental limits ;
  - 4) any substances, other than air, which can be administered by the resuscitator (e.g. oxygen, volatile anaesthetic agents) ;
  - 5) delivered oxygen concentrations under various test conditions ;
  - 6) delivered volume range ;
  - 7) resuscitator deadspace, backward leakage and forward leakage ;
  - 8) expiratory resistance and inspiratory resistance, and the resistance imposed by any recommended accessory ;
  - 9) the end-expiratory pressure generated by the resuscitator in normal use, if greater than 0,2 kPa ( $\approx 2 \text{ cmH}_2\text{O}$ ) ;
  - 10) details of the pressure-limiting system and override mechanism operation, if any ;
  - 11) accuracy of controls or indicating devices, if any, supplied with the resuscitator ;
  - 12) external dimensions of the resuscitator and, if provided, the resuscitator case ;
  - 13) mass of the resuscitator and, if provided, the resuscitator case ;
- d) instructions for the dismantling and reassembly of components for cleaning (including cleaning of any vomitus) and sterilization (if applicable), and details of a functional test of operation to be carried out after reassembly.

NOTE These instructions can be given, if possible, with a schematic also ;

- e) recommended methods of cleaning and disinfection or sterilization of the resuscitator, its components and its accessories if applicable ;
- f) functional test for operation to be carried out prior to use ;
- g) list of operator-replaceable parts ;
- h) maintenance requirements ;
- i) guidance regarding use in hazardous or explosive atmospheres, including a warning that if the resuscitator will entrain or permit the patient to inhale gas from the atmosphere, its use in contaminated environments can be hazardous unless entrainment is prevented. If applicable, a description of how to prevent such entrainment or inhalation, e.g. by the use of a filter ;
- j) warnings that in the presence of high oxygen concentrations there is danger from smoking or naked flames and that oil or grease should not be used with the resuscitator ;
- k) for sterile resuscitators or parts, the method of sterilization used.

## Annex A (normative)

### Test methods

#### A.1 General test conditions

The ambient temperature for the duration of the tests shall be between 20 °C and 25 °C, except where otherwise stated. The relative humidity shall be within the range from 45 % r.h. to 75 % r.h., except where otherwise stated.

#### A.2 Apparatus

##### A.2.1 General

Typical test apparatus is shown in Figures A.1 to A.5 ; alternative test apparatus of equivalent or greater accuracy may be used.

**A.2.2 Test lung** (see Figures A.4 and A.5 for examples), with appropriate compliance and resistance characteristics (see Tables A.1 and A.2).

**A.2.3 Resistors**, if not provided with the test lung.

**A.2.4 Apparatus for the measurement and the recording of pressure, flow and volume.**

**A.2.5 Apparatus for the measurement of temperatures.**

**A.2.6 Apparatus for the measurement of deadspaces** (see Figure A.3 for typical example).

**A.2.7 Graduated cylinder**, of at least 200 ml capacity.

**A.2.8 Oxygen analyzer.**

**A.2.9 Water reservoir**, sufficiently large to permit complete immersion of the resuscitator.

**A.2.10 Environmental chamber**, capable of maintaining temperatures from - 40 °C ± 1 °C to + 70 °C ± 1 °C and relative humidity from 15 % r.h. to 95 % r.h. for periods of up to 7 days.

#### A.3 Conditioning and reference conditions

##### A.3.1 Conditioning of resuscitator and test apparatus

Unless otherwise specified in particular tests, place the resuscitator and test apparatus in the test location and allow sufficient time for the resuscitator and apparatus to reach equilibrium with ambient conditions.

##### A.3.2 Reference conditions

Correct all test readings to the reference conditions of Normal Temperature and Pressure, Dry (NTPD) (20 °C, 1 atm<sup>1)</sup>, 0 % relative humidity).

---

1) 1 atm = 101 325 Pa = 760 mmHg.....

## A.4 Test procedures

### A.4.1 Bag refill valve connectors

Using a 32 mm male gauge (see Figure A.1), measure the internal diameter of the connector.

### A.4.2 Dismantling and reassembly

Verify by inspection of the resuscitator and accompanying documents that a functional test has been provided to test operation after reassembly.

### A.4.3 Valve function after contamination with vomitus

#### A.4.3.1 Test material

Simulated vomitus, prepared by mixing two parts of baby meal beef with vegetable and one part water.

#### A.4.3.2 Procedure

Warm the simulated vomitus to  $(37 \pm 3) ^\circ\text{C}$  and pour 175 ml into the patient connection port. Then cycle the resuscitator at a rate of 30 breaths/min for resuscitators suitable for use with patients of a body mass up to 10 kg, or at a rate of 12 breaths/min for all other models. Perform this test with the resuscitator connected to the test lung (A.2.2). Continue to cycle the resuscitator for 30 s. Clear the resuscitator of the mixture according to the manufacturer's instructions and verify the resuscitator's performance.

NOTE Some of the test solution can spill over when poured into the patient connection port.

### A.4.4 Drop test

Stabilize the resuscitator at the minimum functioning temperature recommended by the manufacturer.

Drop the resuscitator from a height of 1 m onto a concrete floor in the worst case orientation. For the purpose of this test, the resuscitator shall be a complete unit, but without the face mask and attached accessories.

Repeat the test 6 times.

### A.4.5 Immersion in water

Arrange the resuscitator in its ready-for-use condition and drop it from a height of 1 m into the water reservoir (A.2.9). Take the resuscitator out after 10 s and remove the water by shaking and/or squeezing for not more than 20 s. Begin ventilating the test lung (A.2.2) immediately.

### A.4.6 Supplementary oxygen and delivered oxygen concentration

Connect the resuscitator to the test lung (A.2.2) set at C 20 and R 20 characteristics (see Tables A.1 and A.2). Connect an oxygen analyzer (A.2.8) at a site in the compliance chamber as far away as possible from the patient connection port. Ventilate the test lung at a frequency of 12 breaths/min and a tidal volume of 600 ml. Introduce input oxygen flows of no more than 15 l/min. Continue this procedure until a stable value for oxygen concentration is achieved. Use only one hand with maximum allowable hand dimensions given in Figure A.2 to compress the compressible unit.

### A.4.7 Expiratory resistance

For resuscitators suitable for use with patients with a body mass of up to 10 kg, connect the patient connection port to an air source and introduce air at a flow of 5 l/min. Record the pressure generated at the patient connection port.

For all other resuscitators, connect the patient connection port to the air source and introduce air at a flow of 50 l/min. Record the pressure generated at the patient connection port.



#### A.4.8 Inspiratory resistance

For resuscitators suitable for use with patients with a body mass of up to 10 kg, connect the patient connection port to a vacuum source producing an air flow of 5 l/min. Record the pressure generated at the patient connection port.

For all other resuscitators, connect the patient connection port to a vacuum source producing an air flow of 50 l/min. Record the pressure generated at the patient connection port.

#### A.4.9 Patient valve malfunction

Connect the resuscitator to the test lung (A.2.2) set at C 20 and R 20 characteristics (see Tables A.1 and A.2). Ventilate the test lung at a frequency of 12 breaths/min and a tidal volume of 600 ml. Add air or oxygen, as recommended by the manufacturer, at a rate of 30 l/min.

Verify that a positive end expiratory pressure does not exceed 0,6 kPa ( $\approx 6$  cmH<sub>2</sub>O).

#### A.4.10 Resuscitator deadspace

##### A.4.10.1 Principle

Ventilation by the resuscitator of a “bag-in-bottle” reservoir with 100 % (V/V) oxygen as tracer gas. Calculation of the total deadspace of the resuscitator from the volume of ventilation and the oxygen concentration of the inspired gas captured inside the bag.

##### A.4.10.2 Preparation of test apparatus prior to testing resuscitator

Set up the deadspace measurement apparatus (A.2.6; see Figure A.3). Close the tap to the oxygen analyzer (A.2.8). Open the ball valve. Connect the resuscitator and ventilate until the balloon fills the container completely and is pressed against the inner walls. Close the ball valve. Open the oxygen analyzer tap. Open the flowmeter and fill the container with 100 % (V/V) oxygen. Close the oxygen flowmeter when the pressure gauge reads approximately 1 kPa ( $\approx 10$  cmH<sub>2</sub>O) and close the oxygen analyzer tap.

Connect the 22 mm/15 mm test connector to the 22 mm female socket and supply the appropriate flow of atmospheric air to the side nipple (see Table A.3).

Open the ball valve, whereby the expiratory flowpath is flushed with 100 % (V/V) oxygen.

Ventilate the lung by covering and opening the 10 mm diameter hole with a finger. Hold the tidal volume constant by means of the respirometer and pressure gauge. The number of ventilating cycles is given in Table A.3.

Close the ball valve and open the analyzer tap. Adjust the 100 % (V/V) oxygen flow to approximately 5 l/min. Record the reading for the oxygen concentration in the bag,  $F_{bO_2}$ , of the oxygen analyzer. Close off the oxygen flow when the pressure gauge reads 1 kPa ( $\approx 10$  cmH<sub>2</sub>O) again.

Determine the internal deadspace of the test apparatus for every combination of test parameters used.

The test apparatus is now ready for testing the resuscitator.

##### A.4.10.3 Procedure

Test the resuscitator using the same procedure as described for the test connector (see A.4.10.2).

##### A.4.10.4 Expression of results

Calculate the system deadspace (i.e. with test connector) using the following equation :

$$V_{D,\text{system}} = \frac{F_{bO_2(\text{test connection})} - 21}{79} \times V_T$$

with

## ISO 10651-4:2002(E)

$V_{D,\text{system}}$  = system deadspace ;

$F_{bO_2}$  = oxygen concentration (in the bag).

NOTE The apparatus should be so designed that  $V_{D,\text{system}} = 20$  ml or less.

Calculate the apparatus deadspace of the resuscitator being tested using the following equation :

$$V_{D,\text{app}} = \frac{F_{bO_2} - 21}{79} \times V_T - V_{D,\text{system}}$$

### A.4.11 Tidal volume

Connect the resuscitator to the appropriate test lung (A.2.2 ; see Figures A.4 and A.5) having the characteristics stated in Tables A.1 and A.2. Measure the volume (A.2.4). Use only one hand of maximum allowable hand dimensions shown in Figure A.2 to compress the compressible unit. Perform these tests without the use of an override mechanism if one is provided.

NOTE In the absence of leaks (which is the case in the testing conditions)  $V_{\text{del}}$  has the same value as the simulated  $V_T$ .

### A.4.12 Pressure limitation

For resuscitator classified for use with patients up to 10 kg body mass, occlude the patient connection port and, using the compressed air source, pass air at a flow of 15 l/min through the pressure-limiting system. Record the pressure at the patient connection port.

For resuscitators classified for use with patients of over 10 kg body mass and equipped with pressure-limiting systems, occlude the patient connection port and, using the compressed air source, pass air at a flow of 60 l/min through the pressure-limiting system. Record the pressure at the patient connection port.

### A.4.13 Operating conditions

#### A.4.13.1 General

Following completion of each phase of the test, operate the resuscitator under the conditions described in the general requirements in A.1 and also under the specific conditions for the category of resuscitator being tested.

If the manufacturer declares a operating temperature range narrower than - 18 °C to + 50 °C, the declared temperature(s) shall be substituted in tests A.4.13.2.1 and A.4.13.2.4.

NOTE These tests can be performed in any order and on different samples.

#### A.4.13.2 Procedure

NOTE In each of the operational tests given, the resuscitator should be operated continuously (12 breaths/min) for a period of at least 10 min.

**A.4.13.2.1** Prepare the resuscitator in accordance with A.4.13.1. Place the resuscitator system in the environmental chamber (A.2.10) set at either 50 °C or at the lower temperature stated by the manufacturer (see A.4.13.1) and at least 95 % relative humidity. Maintain these conditions for no fewer than 7 days. At the end of this period, operate and test the resuscitator at this temperature.

**A.4.13.2.2** Place the resuscitator in the environmental chamber set at - 40 °C for a period of at least 6 h.

At the end of this period, place the resuscitator in an ambient temperature between 20 °C and 25 °C at a relative humidity between 45 % and 75 % r.h. Allow the resuscitator to stabilize for at least 4 h. At the end of this period, operate and test the resuscitator.

**A.4.13.2.3** Place the resuscitator in the environmental chamber at 60 °C and at a relative humidity of between 40 % r.h. and 70 % r.h. for a period of not less than 4 h.

At the end of this period, place the resuscitator, in ambient conditions of 20 °C to 25 °C at a relative humidity between 45 % and 75 %. Allow the resuscitator to stabilize for 4 h. At the end of this period, operate and test the resuscitator.

**A.4.13.2.4** Place the resuscitator in the environmental chamber set at either -18 °C or the higher temperature stated by the manufacturer (see A.4.13.1) for 4 h. At the end of this period, operate and test the resuscitator at this temperature.

Dimensions in millimetres

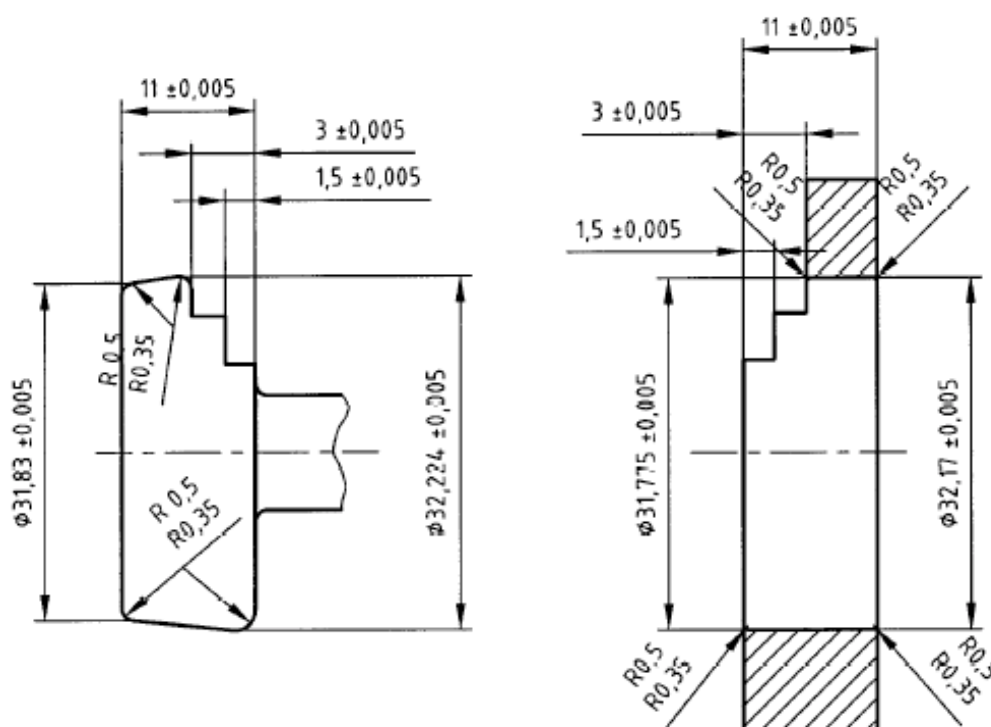

NOTE 1 Basic taper is 1:28 on diameter.

NOTE 2 Engagement is 9,5 nominal.

Figure A.1 — 32 mm ring and plug gauges

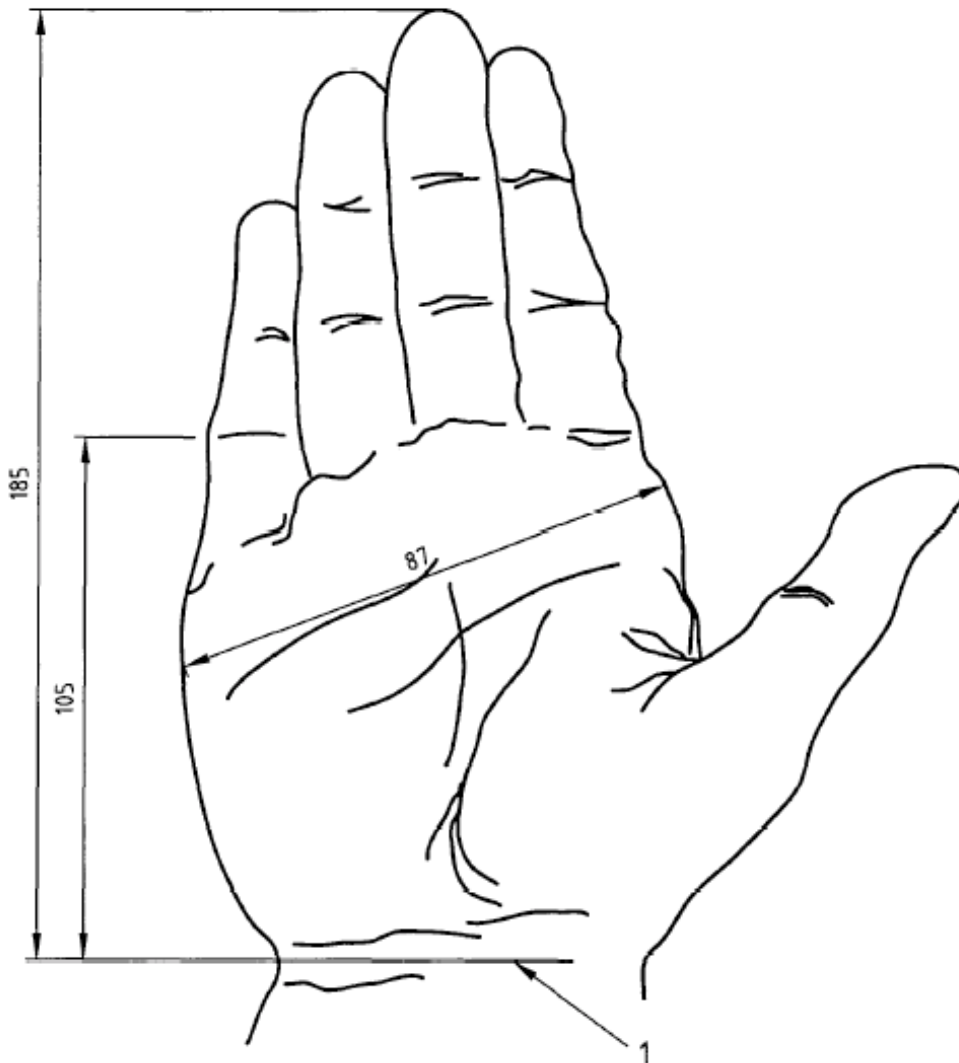

**Key**

- 1 Distal skin crease

**Figure A.2 — Maximum hand dimensions**

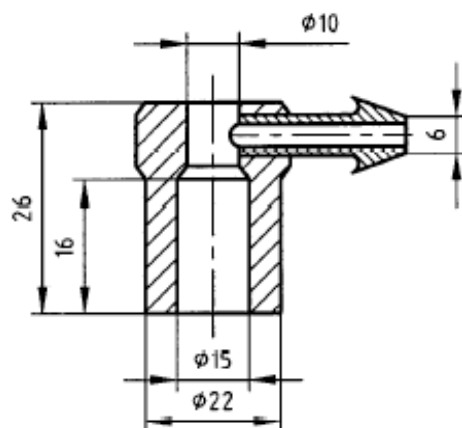

Figure A.3 a) - Test connector for  $V_{D,system}$  test

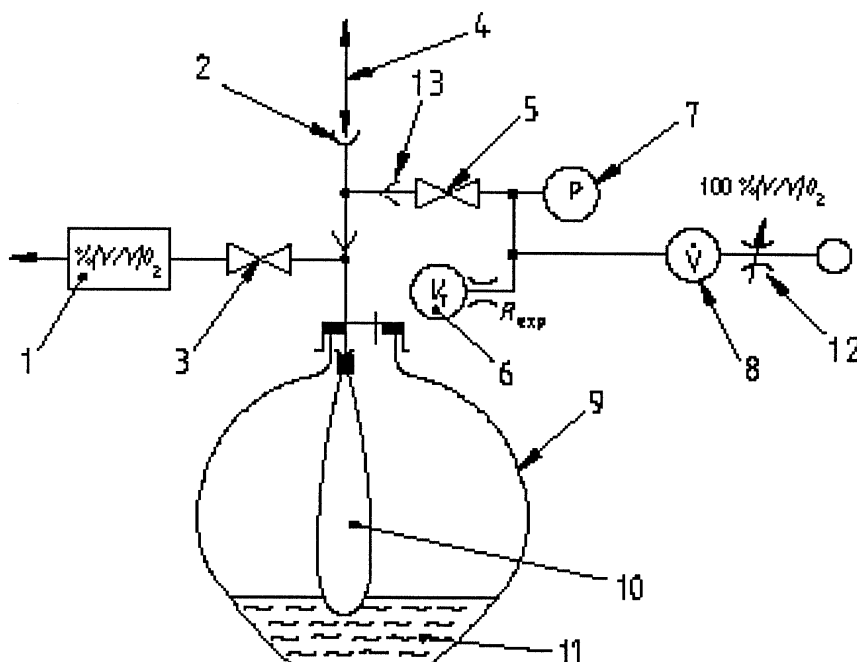
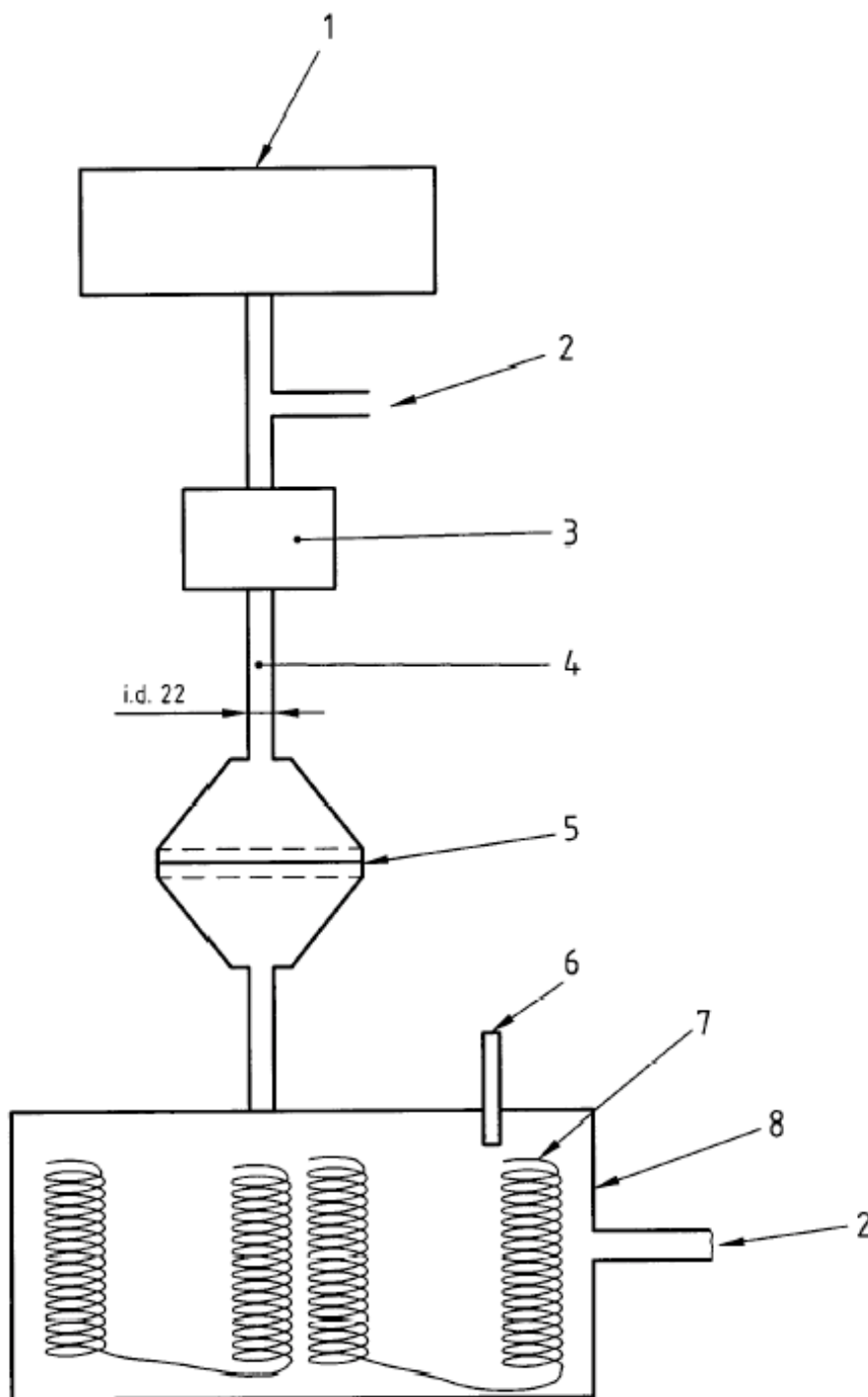

Figure A.3 b) - Test apparatus

**Key**

- |   |  |    |  |
|---|--|----|--|
| 1 | Oxygen analyzer                                | 8  | Flowmeter  |
| 2 | 22 mm female socket                            | 9  | Transparent rigid container volume 25 l to 30 l                          |
| 3 | Tap  | 10 | Latex balloon, approximately 10 l ( $P_{\text{expan}} < 2 \text{ kPa}$ ) |
| 4 | Resuscitator being tested for $V_{D,app}$ test | 11 | Water for adjustment of compliance                                       |
| 5 | Ball valve                                     | 12 | Adjustable needle valve  |
| 6 | Gauge for measuring tidal volume               | 13 | One-way valve  |
| 7 | Pressure gauge                                 |    |  |

Figure A.3 — Test set-up for measuring resuscitator deadspace



**Key**

- 1 Resuscitator
- 2 Pressure tapping point
- 3 Flowmeter
- 4 Rigid tubing

- 5 Model resistance (R5 to R400)
- 6 Thermometer
- 7 Copper wire
- 8 Model compliance (C1 to C50)

**Figure A.4 — Representative passive test lung system**

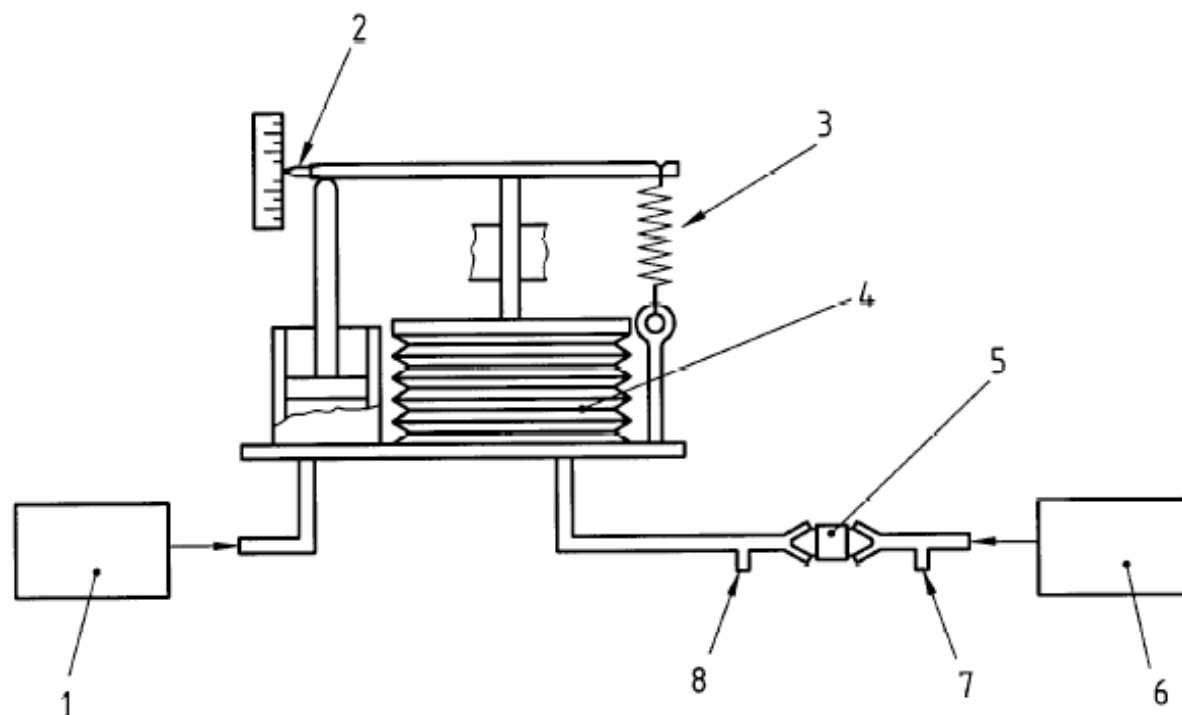

### Key

- |   |                               |   |  |
|---|-------------------------------|---|--|
| 1 | Spontaneous breath generator  | 5 | Calibrated resistor                                |
| 2 | Tidal volume reading          | 6 | Resuscitator under test                            |
| 3 | Compliance setting spring     | 7 | Pressure tapping point (inlet pressure, $p_1$ )    |
| 4 | Bellows or expansible element | 8 | Pressure tapping point (alveolar pressure, $p_2$ ) |

Figure A.5 — Example of active test lung system

Table A.1 — Required compliances to set up test lung

	Compliance $C$	
	l/kPa	equivalent in ml/cm H <sub>2</sub> O
C 50 <sup>a</sup>	0,5	50
C 20	0,2	20
C 10	0,1	10
C 1	0,01	1

<sup>a</sup> Not directly specified.

**Table A.2 — Required resistances to set up test lung**

	Resistance <i>R</i>		Range of air flow <sup>a</sup> l/s
	kPa/(l/s)	equivalent in cm H <sub>2</sub> O/(l/s)	
R 5	0,5	5	0 to 2
R 20	2	20	0,5 to 1
R 50 <sup>b</sup>	5	50	0,25 to 0,5
R 400	40	400	0,05 to 0,075

<sup>a</sup> The tolerances for the low range values are ± 20 % for linear resistances.

<sup>b</sup> Not directly specified in test procedure.

**Table A.3 — Test parameters for determination of resuscitator deadspace**

Tidal volume <i>V<sub>T</sub></i>	Compliance <i>C</i>		Expiratory resistance <i>R<sub>exp</sub></i>		Test flow for internal deadspace l/min	Test cycles
	l/kPa	equivalent in ml/cm H <sub>2</sub> O	kPa/(l/s)	equivalent in cm H <sub>2</sub> O/(l/s)		
600	0,2	20	0,5	5	30	> 15
100	0,1	10	2	20	5	> 50



## **Annex B** (informative)

### **Rationale**

#### **B.4.2 Expiratory port for breathing gases**

The exhaust connection described is that used for connection to the transfer tubes of anaesthetic gas scavenging systems. It is essential that breathing system conical connectors are not compatible with this port. It is also important that the exhaust port be designed such that it cannot be confused with the inspiratory port during use of the resuscitator.

#### **B.4.4 Bag refill valve connectors**

The size of this connector is chosen to prevent the accidental fitting of demand valves with manual controls.

#### **B.5.2 Dismantling and reassembly**

Wrongly assembling a resuscitator so that it causes incorrect operation or complete malfunction is a serious hazard which can result in inadequate ventilation of the patient.

#### **B.5.3 Patient valve function after contamination with vomitus**

It is important that vomitus can be quickly and effectively cleared from a resuscitator so that resuscitation can be continued with a minimum of interruption.

##### **B.5.4.1 Drop test**

It is important that resuscitators can withstand severe shock caused by falls from ambulances, hospital beds, etc.

#### **B.5.5 Immersion in water**

Resuscitators are often used in areas where the device might be inadvertently dropped into water during the resuscitation. If the unit is recovered quickly from the water, it should still function.

#### **B.5.6 Bag refill valves**

It is imperative that demand valves with manual controls are not accidentally substituted for bag refill valves. Such valves are capable of high gas flows that can cause resuscitator patient valves to jam.

#### **B.6.1 Supplementary oxygen and delivered oxygen concentration**

Although 35 % (V/V) oxygen concentration is adequate under some circumstances, 85 % (V/V) or higher oxygen concentrations are preferable for the treatment of severely hypoxaemic patients during resuscitation. This concentration should be achievable at supplementary oxygen flows of 15 l/min or less because to specify greater than 15 l/min would exceed the normal calibration of standard, clinically used flowmeters for adult use and could potentially lead to inaccurate control of oxygen flows and jamming of the patient valve in the inspiratory position.

### **B.6.2 Expiratory resistance**

To facilitate exhalation, expiratory resistance should be minimized unless there are special clinical indications to impose such resistance.

### **B.6.3 Inspiratory resistance**

The design of a resuscitator should be such that it is possible for the patient to breathe spontaneously without excessive subatmospheric pressure when the resuscitator is applied to the patient's airway but is not activated by the operator.

### **B.6.4 Patient valve malfunction**

Valve malfunction or jamming in the inspiratory position at high supplementary oxygen flow can lead to failure of the resuscitator and transmission of excessive pressures to the patient. Resuscitators are commonly used at oxygen input flows of 15 l/min, but flowmeter valves can be capable of permitting flows of over 30 l/min. It is essential to follow the manufacturer's instructions and to use only attachments recommended for use with the resuscitator.

### **B.6.5 Patient valve leakage - Forward leakage**

If forward leakage is a design feature of a resuscitator, this should be disclosed so that the user does not confuse this leakage with a malfunction.

### **B.6.6 Apparatus deadspace**

It is essential to minimize apparatus dead space in order to limit rebreathing of expired gases.

### **B.6.7 Ventilation performance**

The sub-atmospheric pressure generated by a patient when first starting to breathe spontaneously may be very small. With some designs of patient valve, there is a potential risk that in this situation either or both of the inspiratory and expiratory components may not be fully competent and may thus permit rebreathing.

#### **B.6.7.1 Delivered volume**

For adult ventilation a typical tidal volume is approximately 600 ml. The compliances and resistances listed in Table 1 are representative of the possible compliances and resistances found in adults and children needing resuscitation. The tidal volume requirements of 15 ml/kg are higher than normal and are commonly used during resuscitation to allow for mask leakage. The ventilatory are typical values used in paediatric and adult resuscitation.

Experience shows that, due to leaks and changing compliance during resuscitation of neonates, given delivered volumes of the order of 20 ml to 30 ml are needed to achieved a tidal volume of 20 ml or less.

### B.6.7.2 Pressure limitation

Experience with infant resuscitation suggests that a maximum inspiratory pressure of 4,5 kPa (45 cmH<sub>2</sub>O) will not produce lung damage and will permit adequate tidal volumes in most patients weighing under 10 kg.

Pressure-limiting systems are not specified for operator-powered resuscitators designated for use with patients weighting over 10 kg. However, it is essential that resuscitators with such systems satisfy the tidal volume requirements specified in this European Standard (see table 1) without the use of any override mechanism. When airway pressure is limited to below 6 kPa (60 cmH<sub>2</sub>O), it is believed that an override mechanism is essential in order to ventilate those patients with low lung compliance and/or high airway resistance.

Resuscitators with pressure limiting systems which limits the airway pressure to less than 3 kPa ( $\approx$  30 cm H<sub>2</sub>O) may not be able to deliver adequate volume to children with a body weight below 10 kg in case of high airway resistance and/or reduced lung compliance.

### B.7.2 Operating conditions

Resuscitators can be expected to be exposed to the temperature extremes outlines in 7.2 since such temperatures frequently occur throughout the world in environments where resuscitators are used.

## Bibliography

EN 980 *Graphical symbols for use in the labelling of medical devices.*



---

---

**ICS 11.040.10**

Price based on 22 pages

© ISO 2002 – All rights reserved