**Cutter arbors with parallel key and
tenon drive —**

**Part 2:
Dimensions and designation of tool
holders with taper interface with
flange contact surface**

Mandrins porte-fraise à entraînement par clavette et tenon —

*Partie 2: Dimensions et désignation des porte-outils avec interface à
cône creux-face*





COPYRIGHT PROTECTED DOCUMENT

© ISO 2013

All rights reserved. Unless otherwise specified, no part of this publication may be reproduced or utilized otherwise in any form or by any means, electronic or mechanical, including photocopying, or posting on the internet or an intranet, without prior written permission. Permission can be requested from either ISO at the address below or ISO's member body in the country of the requester.

ISO copyright office
Case postale 56 • CH-1211 Geneva 20
Tel. + 41 22 749 01 11
Fax + 41 22 749 09 47
E-mail copyright@iso.org
Web www.iso.org

Published in Switzerland

Contents

	Page
Foreword	iv
Introduction	v
1 Scope	1
2 Normative references	1
3 Dimensions	1
3.1 General	1
3.2 Dimensions of cutter arbors with parallel key and tenon drive with hollow taper interface	1
4 Material	2
5 Designation	2
6 Delivery conditions	3
Annex A (informative) Relationship between the symbols of this part of ISO 10649 and the ISO 13399 series	4
Bibliography	5

Foreword

ISO (the International Organization for Standardization) is a worldwide federation of national standards bodies (ISO member bodies). The work of preparing International Standards is normally carried out through ISO technical committees. Each member body interested in a subject for which a technical committee has been established has the right to be represented on that committee. International organizations, governmental and non-governmental, in liaison with ISO, also take part in the work. ISO collaborates closely with the International Electrotechnical Commission (IEC) on all matters of electrotechnical standardization.

The procedures used to develop this document and those intended for its further maintenance are described in the ISO/IEC Directives, Part 1. In particular the different approval criteria needed for the different types of ISO documents should be noted. This document was drafted in accordance with the editorial rules of the ISO/IEC Directives, Part 2. www.iso.org/directives

Attention is drawn to the possibility that some of the elements of this document may be the subject of patent rights. ISO shall not be held responsible for identifying any or all such patent rights. Details of any patent rights identified during the development of the document will be in the Introduction and/or on the ISO list of patent declarations received. www.iso.org/patents

Any trade name used in this document is information given for the convenience of users and does not constitute an endorsement.

The committee responsible for this document is ISO/TC 29, *Small tools*, Subcommittee SC 2, *High speed steel cutting tools and their attachments*.

This second edition cancels and replaces the first edition (ISO 10649-2:2010), of which it constitutes a minor revision with the following changes:

- addition of [Annex A](#), which gives the relationship between the symbols of this part of ISO 10649 and the symbols according to the ISO 13399 series.

ISO 10649 consists of the following parts, under the general title *Cutter arbors with parallel key and tenon drive*:

- *Part 1: General dimensions*
- *Part 2: Dimensions and designation of tool holders with taper interface with flange contact surface*
- *Part 3: Dimensions and designation of tool holders with 7/24 taper for automatic tool changer*
- *Part 4: Dimensions and designation of tool holders with 7/24 taper without automatic tool changer*
- *Part 5: Dimensions and designation of tool holders with polygonal taper interface with flange contact surface*
- *Part 6: Dimensions and designation of tool holders with modular taper interface with ball track system*

Introduction

The aim of ISO 10649 (all parts) is to specify the main dimensions for tool holders for this type of interface, and prevent the risk of collision when exchanging the assembled tool within the machine tools.

.....

.....

Cutter arbors with parallel key and tenon drive —

Part 2:

Dimensions and designation of tool holders with taper interface with flange contact surface

1 Scope

This part of ISO 10649 specifies the dimensions of cutter arbors with parallel key and tenon drive with hollow taper interface (HSK) with flange contact surface.

2 Normative references

The following documents, in whole or in part, are normatively referenced in this document and are indispensable for its application. For dated references, only the edition cited applies. For undated references, the latest edition of the referenced document (including any amendments) applies.

ISO 2768-1, *General tolerances — Part 1: Tolerances for linear and angular dimensions without individual tolerance indications*

ISO 2768-2, *General tolerances — Part 2: Geometrical tolerances for features without individual tolerance indications*

ISO 2780, *Milling cutters with tenon drive — Interchangeability dimensions for cutter arbors — Metric series*

ISO 10643, *Dimensions of accessories for cutter arbors with parallel key and tenon drive*

ISO 10649-1, *Cutter arbors with parallel key and tenon drive — Part 1: General dimensions*

ISO 12164-1, *Hollow taper interface with flange contact surface — Part 1: Shanks — Dimensions*

3 Dimensions

3.1 General

All dimensions and tolerances are given in millimetres. Tolerances not specified shall be of tolerance class “m” in accordance with ISO 2768-1 and of class “K” in accordance with ISO 2768-2.

The interchangeability dimensions of the milling cutter bearing on the cutter arbors shall be in accordance with ISO 2780.

The dimensions of the tool interface for arbors with parallel key and tenon drive shall be in accordance with dimensions given in ISO 10649-1.

The figures are schematic and are not intended to specify a given design; only the given dimension shall be met.

3.2 Dimensions of cutter arbors with parallel key and tenon drive with hollow taper interface

The dimensions of cutter arbors with parallel key and tenon drive with hollow taper interface with flange contact surface shall be in accordance with the dimensions shown in [Figure 1](#) and given in [Table 1](#).

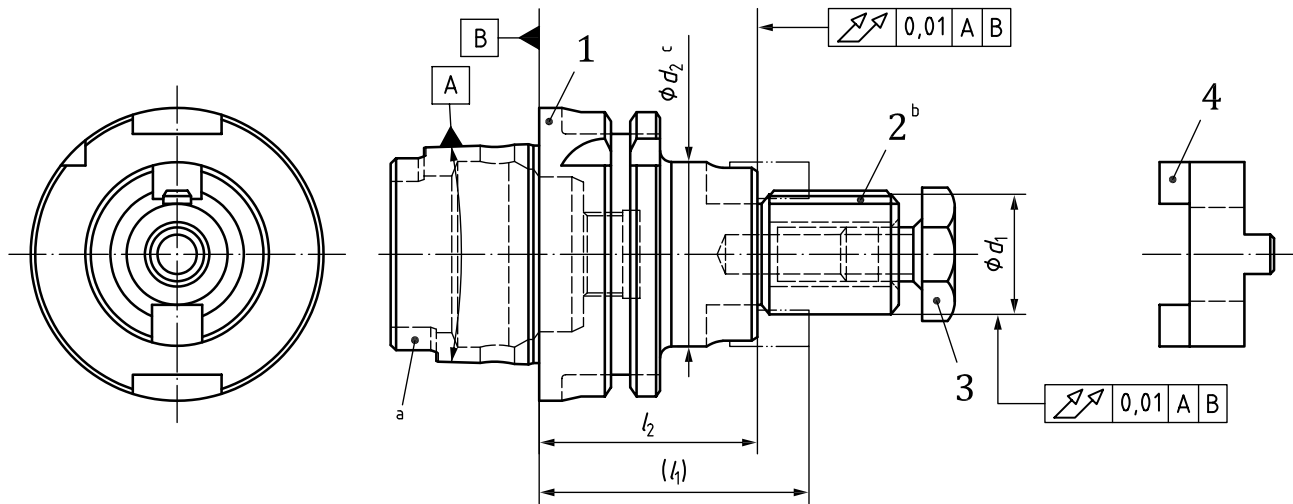

Key

- 1 tool holder with HSK
- 2 parallel key in accordance with ISO 10643
- 3 cutter retaining screw in accordance with ISO 10643
- 4 clutch drive ring in accordance with ISO 10643
- a Hollow taper interface (HSK) in accordance with ISO 12164-1.
- b Not convex.
- c The values of d_2 shall be as given in ISO 10649-1.

Figure 1 — Cutter arbors with parallel key and tenon drive and with hollow taper interface

Table 1 — Dimensions

HSK nominal size	32			40			50			63				80				100								
	d_1	l_1	l_2	d_1	l_1	l_2	d_1	l_1	l_2	d_1	l_1	l_2	d_1	l_1	l_2	d_1	l_1	l_2	d_1	l_1	l_2	d_1	l_1	l_2		
	16	22	27	16	22	27	16	22	27	32	16	22	27	32	40	16	22	27	32	40	16	22	27	32	40	50
	55	55	65	50	55	65	50	55	65	65	60	60	60	65	70	60	60	60	60	70	60	60	60	60	70	80
	45	43	53	40	43	53	40	43	53	51	50	48	48	51	56	50	48	48	46	56	50	48	48	46	56	64

4 Material

The material is left to the manufacturer’s discretion; the tensile strength shall be at least 800 N/mm².

The surface hardness shall be (56 + 4) HRC in the area of the taper surface and the surfaces of the spigot. The hardness depth is left to the manufacturer’s discretion.

5 Designation

The cutter arbors with parallel key and tenon drive with hollow taper interface in accordance with this part of ISO 10649 shall be designated by:

- a) “Arbor”;
- b) the reference to this part of ISO 10649, i.e. ISO 10649-2:2013;
- c) a hyphen;

- d) HSK;
- e) a hyphen;
- f) HSK type A or C;
- g) the HSK nominal size;
- h) a hyphen;
- i) the diameter of the cutter, d_1 .

EXAMPLE Designation of a regular contact surface arbor with hollow taper interface of type A with nominal size shank 40 mm, cutter diameter $d_1 = 16$ mm, with clutch drive ring and cutter retaining screw:

Arbor ISO 10649-2 - HSK - A 40 - 16

6 Delivery conditions

The cutter arbors with parallel key and tenon drive with hollow taper interface in accordance with this part of ISO 10649 shall be delivered with at least the following:

- a parallel key in accordance with ISO 10643;
- a clutch drive ring in accordance with ISO 10643;
- a cutter retaining screw in accordance with ISO 10643.

Annex A (informative)

Relationship between the symbols of this part of ISO 10649 and the ISO 13399 series

For the relationship between the symbols of this part of ISO 10649 and symbols according to the ISO 13399 series, see [Table A.1](#).

Table A.1 — Relationship between symbols in this part of ISO 10649 and ISO 13399 series

Symbol in this part of ISO 10649 (ISO 10649-2)	Reference in this part of ISO 10649 (ISO 10649-2)	Property name in the ISO 13399 series	Symbol in the ISO 13399 series	Reference in the ISO 13399 series BSU code
d_1	Figure 1	shank diameter	DCONWS	ISO/TS 13399-3 71CF29862B277
d_2	Figure 1	body diameter	BD	ISO/TS 13399-3 7ED689AF7D1D
l_1	Figure 1	functional length	LF	ISO/TS 13399-3 71DCD39338974
l_2	Figure 1	functional length (2)	LF(2)	ISO/TS 13399-3 71DCD39338974_2

Bibliography

- [1] ISO 13399 (all parts), *Cutting tool data representation and exchange*

ICS 25.060.20

Price based on 4 pages