**Diagrams for the chemical and
petrochemical industry —**

**Part 1:
Specification of diagrams**

*Schémas de procédé pour l'industrie chimique et pétrochimique —
Partie 1: Spécification des schémas de procédé*





COPYRIGHT PROTECTED DOCUMENT

© ISO 2014

All rights reserved. Unless otherwise specified, no part of this publication may be reproduced or utilized otherwise in any form or by any means, electronic or mechanical, including photocopying, or posting on the internet or an intranet, without prior written permission. Permission can be requested from either ISO at the address below or ISO's member body in the country of the requester.

ISO copyright office
Case postale 56 • CH-1211 Geneva 20
Tel. + 41 22 749 01 11
Fax + 41 22 749 09 47
E-mail copyright@iso.org
Web www.iso.org

Published in Switzerland

Contents

	Page
Foreword	iv
1 Scope	1
2 Normative references	1
3 Terms and definitions	1
4 Classification, information content, and presentation of flow diagrams	1
4.1 General.....	1
4.2 Block diagrams.....	2
4.3 Process flow diagrams.....	3
4.4 Piping and instrumentation diagrams (P&ID).....	3
5 Drafting rules	4
5.1 General.....	4
5.2 Layout of flow diagrams.....	5
5.3 Connecting lines.....	5
5.4 Inscription.....	7
5.5 Scale.....	8
5.6 Limits.....	8
Annex A (informative) Examples of flow diagrams for process plants	10
Bibliography	16

Foreword

ISO (the International Organization for Standardization) is a worldwide federation of national standards bodies (ISO member bodies). The work of preparing International Standards is normally carried out through ISO technical committees. Each member body interested in a subject for which a technical committee has been established has the right to be represented on that committee. International organizations, governmental and non-governmental, in liaison with ISO, also take part in the work. ISO collaborates closely with the International Electrotechnical Commission (IEC) on all matters of electrotechnical standardization.

The procedures used to develop this document and those intended for its further maintenance are described in the ISO/IEC Directives, Part 1. In particular the different approval criteria needed for the different types of ISO documents should be noted. This document was drafted in accordance with the editorial rules of the ISO/IEC Directives, Part 2 (see www.iso.org/directives).

Attention is drawn to the possibility that some of the elements of this document may be the subject of patent rights. ISO shall not be held responsible for identifying any or all such patent rights. Details of any patent rights identified during the development of the document will be in the Introduction and/or on the ISO list of patent declarations received (see www.iso.org/patents).

Any trade name used in this document is information given for the convenience of users and does not constitute an endorsement.

For an explanation on the meaning of ISO specific terms and expressions related to conformity assessment, as well as information about ISO's adherence to the WTO principles in the Technical Barriers to Trade (TBT) see the following URL: Foreword - Supplementary information

The committee responsible for this document is ISO/TC 10, *Technical product documentation*, Subcommittee SC 10, *Process plant documentation*.

This first edition of ISO 10628-1, along with ISO 10628-2, cancels and replaces ISO 10628:1997, which has been technically revised.

ISO 10628 consists of the following parts, under the general title *Diagrams for chemical and petrochemical industry*:

- *Part 1: Specifications of diagrams*
- *Part 2: Graphical symbols*

Diagrams for the chemical and petrochemical industry —

Part 1: Specification of diagrams

1 Scope

This part of ISO 10628 specifies the classification, content, and representation of flow diagrams. In addition, it lays down drafting rules for flow diagrams for chemical and petrochemical industry.

This International Standard does not apply to electrical engineering diagrams. This part of ISO 10628 is a collective application standard of ISO 15519.

2 Normative references

The following documents, in whole or in part, are normatively referenced in this document and are indispensable for its application. For dated references, only the edition cited applies. For undated references, the latest edition of the referenced document (including any amendments) applies.

ISO 128 (all parts), *Technical drawings — General principles of presentation*

ISO 7200, *Technical product documentation — Data fields in title blocks and document headers*

ISO 10209, *Technical product documentation — Vocabulary — Terms relating to technical drawings, product definition and related documentation*

ISO 14617 (all parts), *Graphical symbols for diagrams*

ISO 15519 (all parts), *Specification for diagrams for process industry*

ISO 80000-1, *Quantities and units — Part 1: General*

IEC 62424:2008, *Representation of process control engineering requests in P&I diagrams and data exchange between P&ID tools and PCE-CAE tools*

3 Terms and definitions

For the purposes of this document, the terms and definitions given in ISO 10209, ISO 14617 (all parts), ISO 15519 (all parts), and IEC 62424 apply.

4 Classification, information content, and presentation of flow diagrams

4.1 General

Flow diagrams show the structure and function of the process plants and are part of the entire set of technical documents which are required for planning, assembly, construction, management, commissioning, operation, maintenance, shutdown, and decommissioning of a plant.

Flow diagrams are a means by which information is exchanged between parties involved in the construction, assembly, operation, and maintenance of such process plants. General rules and recommendations for preparation of flow diagrams are given in ISO 15519.

Depending on the information required, a distinction should be made between block diagrams, process flow diagrams, and piping and instrumentation diagrams (P&ID).

Each particular type of flow diagram shall take the functional requirements into consideration.

The graphical presentation shall conform to the rules set down in [Clause 5](#). Flow routes and flow directions shall be indicated by lines and arrows.

All equipment, machinery, flow lines (e.g. pipelines, transport routes), and valves shall be represented in accordance with ISO 10628-2.

The measuring, control, and regulating tasks shall be represented in accordance with IEC 62424.

Designation of objects in diagrams could be performed using reference designation according to IEC 81346 series.

4.2 Block diagrams

4.2.1 General representation rules

The block diagram depicts a process or process plant in simplified form by means of rectangular frames which are interconnected by flow lines (see [Figures A.1](#) and [A.2](#)).

The rectangular frames can represent the following:

- processes;
- process steps;
- unit operations;
- process plants or groups of process plants;
- plant sections;
- equipment.

The flow lines can represent streams of materials or energy flows.

4.2.2 Basic information

The block diagram shall contain at least the following information:

- a) denomination of frames;
- b) denomination of ingoing and outgoing materials;
- c) direction of main material flows between frames.

4.2.3 Additional information

The block diagram can also contain the following information:

- a) denomination of the main material flows between the frames;
- b) flow rates or quantities of ingoing and outgoing materials;
- c) flow rates or quantities of ingoing and outgoing energy or energy carriers;
- d) main material flows between the frames representing energy or energy carriers;
- e) characteristic operating conditions.

4.3 Process flow diagrams

4.3.1 General

The process flow diagram depicts a process or a process plant by means of graphical symbols which are interconnected by lines (see [Figures A.3](#) and [A.4](#)).

A utility flow diagram (UFD) is a special type of process flow diagram. It is a schematic representation of the energy utility systems within a process plant, showing all lines and other graphic means required for the representation of transport, distribution, and collection of forms of energy. In a utility flow diagram, process equipment can be represented by boxes with inscriptions and with utility connections (see [Figure A.5](#)).

The graphical symbols represent equipment and the lines represent flows of mass, energy, or energy carriers.

4.3.2 Basic information

The process flow diagram shall contain at least the following information:

- a) kind of apparatus and machinery, except drives, needed for the process;
- b) designations for equipment and machinery, except drives;
- c) route and direction of the ingoing and outgoing material and energy flows;
- d) denomination and flow rates or quantities of ingoing and outgoing materials;
- e) denomination of energy types and/or energy carriers;
- f) characteristic operating conditions.

4.3.3 Additional information

The process flow diagram can also contain the following additional information:

- a) denomination and flow rates or quantities of materials between the process steps;
- b) flow rates or quantities of energy and/or energy carriers;
- c) essential valves and their arrangement in the process;
- d) functional demands for process measuring and control devices at important points;
- e) supplementary operating conditions;
- f) characteristic data of equipment and machinery (except drives), given in separate lists if necessary;
- g) characteristic data of drives, given in separate lists if necessary;
- h) elevation of platforms and approximate relative vertical position of equipment.

4.4 Piping and instrumentation diagrams (P&ID)

4.4.1 General

The P&ID is based on the process flow diagram and depicts the technical realization of a process by means of graphical symbols representing equipment and piping, together with graphical symbols for process measurement and control functions (see [Figure A.6](#)).

All equipment, valves, and fittings shall be represented in accordance with ISO 10628-2.

The process measuring and control tasks shall be represented in accordance with IEC 62424.

Auxiliary systems can be represented by rectangular frames with references to separate flow diagrams.

4.4.2 Basic information

The piping and instrumentation diagram shall contain at least the following information:

- a) function and type of equipment and machinery, including drives, conveyors, and installed back-up/reserve equipment;
- b) designation of apparatus and machinery, including drives;
- c) characteristic data of equipment and machinery, given in separate lists if necessary;
- d) indication of nominal sizes, pressure ratings, material, and type of piping, e.g. by stating the pipeline number, piping class, or designations;
- e) details of equipment, machinery, piping, valves, and fittings e.g. pipe reducers given in separate list if necessary;
- f) symbols for PCE requests including letter codes for process variables, control functions, and designation of the PCE request;
- g) characteristic data of drives, given in separate lists if necessary.

4.4.3 Additional information

The piping and instrumentation diagram can also contain the following additional information:

- a) denomination and flow rates or amounts of energy or energy carriers;
- b) route and direction of flow of energy or energy carriers;
- c) type of essential devices for process measuring and control;
- d) essential construction materials for equipment and machinery;
- e) elevation of platforms and approximate relative vertical position of equipment;
- f) designations of valves and fittings;
- g) denomination of equipment.

5 Drafting rules

5.1 General

5.1.1 Sheet sizes

A1 size as defined in ISO 5457 should preferably be used for drawing sheets. Considering the various copying techniques (reduction) available, long sizes and sizes larger than A1 are to be avoided.

5.1.2 Title block

The basic title block for drawings and lists (with additional fields) as shown in ISO 7200 shall be used.

5.2 Layout of flow diagrams

Graphical symbols for equipment and machinery could be enlarged in order to give a clear representation of internals and connections.

Devices to be expected at the uppermost level of the plant shall be shown at the top of the drawing and those expected to be located at the lowest level shall be shown at the bottom of the drawing.

The graphical symbols for process-related measuring and control functions for equipment, machinery, and piping, as well as those representing piping and valves, shall be shown in the logical position corresponding to their functions.

5.3 Connecting lines

5.3.1 Line widths

Line widths shall be related to the grid module (in accordance with ISO 81714-1) for flow diagrams, $M = 2,5 \text{ mm}$.

To obtain a clear representation, different line widths shall be used. Lines representing main flows or main piping shall be highlighted.

The following line widths as specified in ISO 128 (all parts) shall be used:

- a) 1,0 mm (0,4 M) for main flow lines;
- b) 0,5 mm (0,2 M) for
 - graphical symbols representing equipment and machinery, except valves and fittings and piping accessories,
 - rectangular frames representing unit operations, process equipment etc.,
 - subsidiary flow lines, and
 - energy carrier lines and auxiliary system lines;
- c) 0,25 mm (0,1 M) for
 - graphical symbols representing valves and fittings and piping accessories,
 - symbols representing process measuring and control functions, control and data transmission lines,
 - reference lines, and
 - other auxiliary lines.

Line widths less than 0,25 mm (0,1 M) shall not be used.

5.3.2 Minimum space of parallel lines

The minimum space between parallel lines shall be at least twice the width of the widest line, but at least equal to 1 mm. Space between flow lines should be greater than 10 mm.

5.3.3 Flow direction

5.3.3.1 General

Normally, the main flow direction shall be drawn from left to right and from top to bottom.

5.3.3.2 Arrows for diagrams in- and outgoing flows

In- and outgoing flows of a diagram, also flows coming from of continuous on other diagrams shall be identified with arrows see [Figure 1](#).

For reversible flows arrows according [Figure 2](#) shall be used.

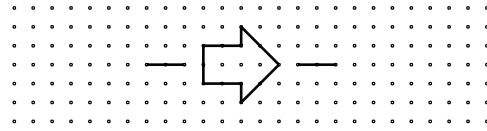

Figure 1 — Arrow for in- and outgoing flow

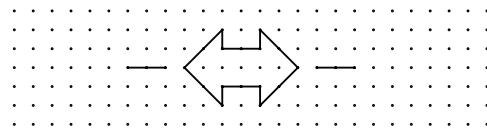

Figure 2 — Arrow for reversible flow

If a diagram consists of several sheets, it is recommended that lines representing incoming and outgoing flows and piping shall be drawn in such a manner that these lines continue at the same level when the individual sheets are placed next to one another horizontally and are aligned vertically.

When a connection line continues to another diagram the end should be mutually referenced. The reference should consist of a designation (see [Figure 3](#)).

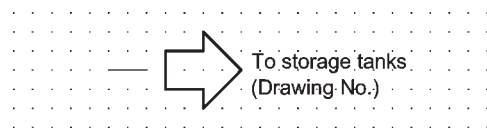

Figure 3 — Arrow for connection line continuing on another diagram (with reference)

5.3.3.3 Arrows for indication of flow direction

Arrows are to be incorporated in the lines to indicate the direction of the flows within the flow diagram. In order to facilitate understanding, arrows can be used at the inlets to equipment and machinery (except for pumps) and upstream of pipe branches (see [Figure 4](#)). Arrow heads for indication of flow can be found in ISO 14617-2.

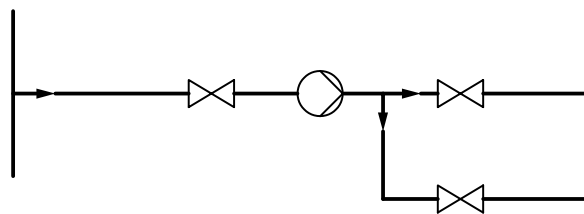

Figure 4 — Examples of arrows for indication of flow direction

5.3.4 Connections

When pipes are represented by the same line width cross, but are not connected to each other, the line depicting the vertical pipe shall be interrupted [see [Figure 5a](#)].

When pipes are represented by different line widths cross, but are not connected to each other, the line depicting the thinner pipe shall be interrupted [see [Figure 5b](#)].

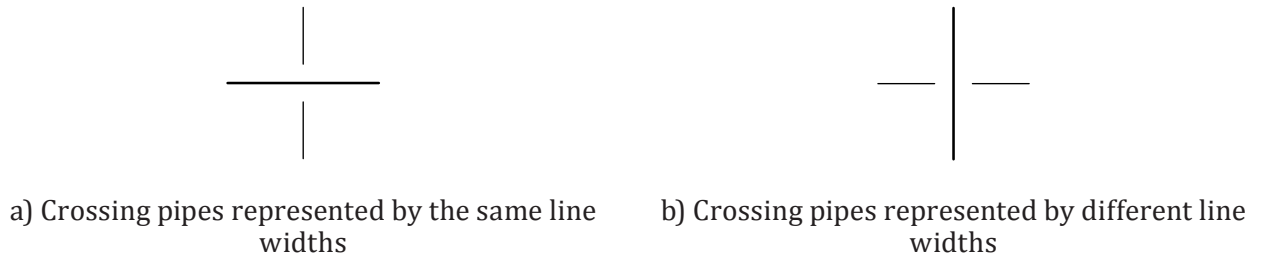

Figure 5 — Representation of unconnected crossing pipes

A pipeline junction (tee) is represented as shown in [Figure 6a](#)). Junctions of pipelines in close proximity are represented as shown in [Figure 6b](#)).

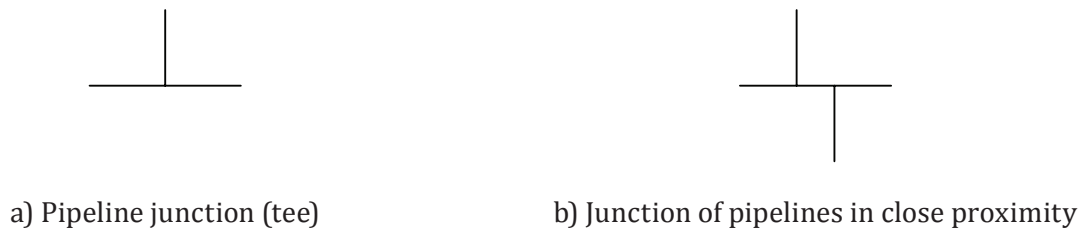

Figure 6 — Representation of connected pipes

5.3.5 Connections of auxiliary system lines

Auxiliary system lines shall be shown by dashed lines with an indication of the flow direction and reference to the type of energy carrier and, if possible, the drawing number.

5.4 Inscription

5.4.1 Type of lettering

Type B vertical lettering in accordance with ISO 3098-2 is recommended.

Legends and designations in flow diagrams shall always be written in upper-case characters. The only exceptions to this rule are chemical formulae (e.g. NaCl), abbreviations referring to technical regulations and legislation (e.g. BImSchG), and other cases where there is a danger of confusion if only upper case characters are used.

5.4.2 Height of lettering

The height of letters shall be:

- a) 5 mm for designations of equipment and machinery;
- b) 2,5 mm for other lettering.

5.4.3 Lettering arrangement

- a) Plant equipment

Reference designations of equipment shall be located so that the relationship is unambiguous, but shall normally not be printed inside the relevant graphic symbol.

Further details (e.g. designation, nominal capacity, pressure, material) can either be placed below the reference designations or shown in separate tables.

b) Flow lines or piping

Designations of flow lines or piping shall be written above and parallel to horizontal lines and to the left of and parallel to vertical lines.

If the beginning and end of flow lines or piping are not immediately recognizable, corresponding elements shall be indicated by identical identification letters.

c) Valves and fittings

Reference designation of valves and fittings shall normally be written next to the corresponding graphic symbol and parallel to the flow direction.

d) Process measurement and control systems

The designation shall be in accordance with IEC 62424.

e) Flow rates and/or quantities, operating conditions, and thermophysical properties

Flow rates and/or quantities, operating conditions, and thermophysical properties shall be entered either in rectangular frames or in a separate table. The frames shall be connected to the reference points by means of reference lines and shall be arranged parallel to and above horizontal lines and to the left or right of vertical lines, respectively. If the data are shown in tabular form, serial numbers corresponding to the data list shall be written in the frames.

f) SI units in accordance with ISO 80000-1 shall be used.

5.5 Scale

When drafting P&IDs, the following aspects shall be taken into account with regard to scales, elevation levels, and piping:

- 1) As a rule, P&I flow diagrams are not drawn to scale. However, in order to illustrate the relative sizes of main equipment and devices, such as vessels, columns, heat exchangers, etc., these should be depicted in the same scale relationship, wherever possible.
- 2) Vessels and equipment shall be drawn or depicted large enough so that all required piping connections can be clearly shown.
- 3) Elevation levels (heights) should only be depicted if this is necessary to improve understanding of the diagram or of technical aspects.
- 4) Pipelines are not bound to elevation levels.

5.6 Limits

For indication limits of materials, supplier, or battery limits, see [Figure 7](#). The information can be placed inside or outside the symbol.

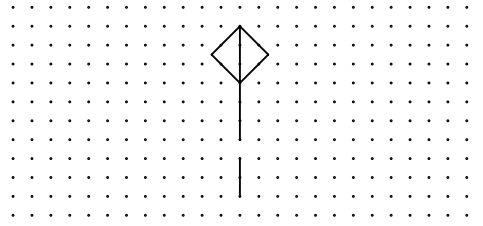

Figure 7 — Indication of limits

Annex A (informative)

Examples of flow diagrams for process plants

The [Figures A.1](#) to [A.6](#) in this Annex are only examples of the flow diagrams described in this part of ISO 10628; their technical content is not the subject of this part of ISO 10628.

Due to the high reduction of the diagram examples, some information e.g. designations are not completely shown in order to secure reasonable readability.

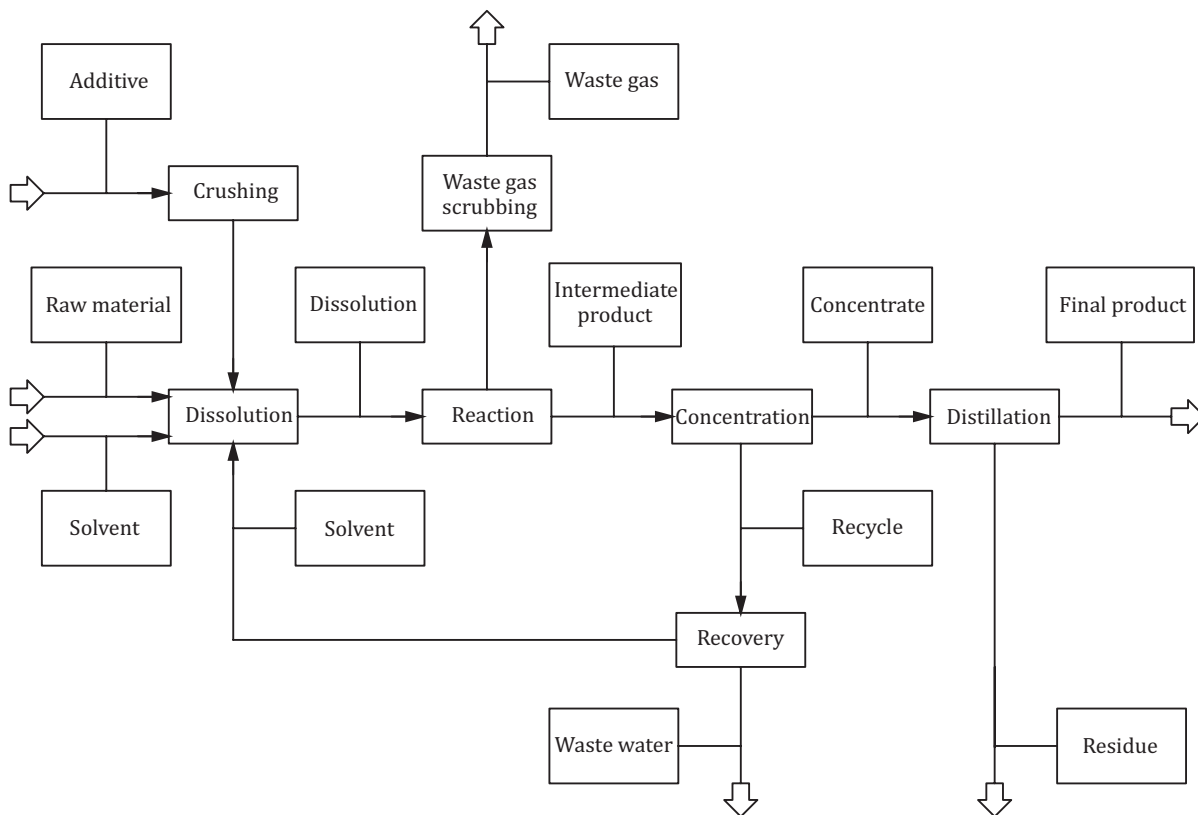

Figure A.1 — Block diagram with basic information

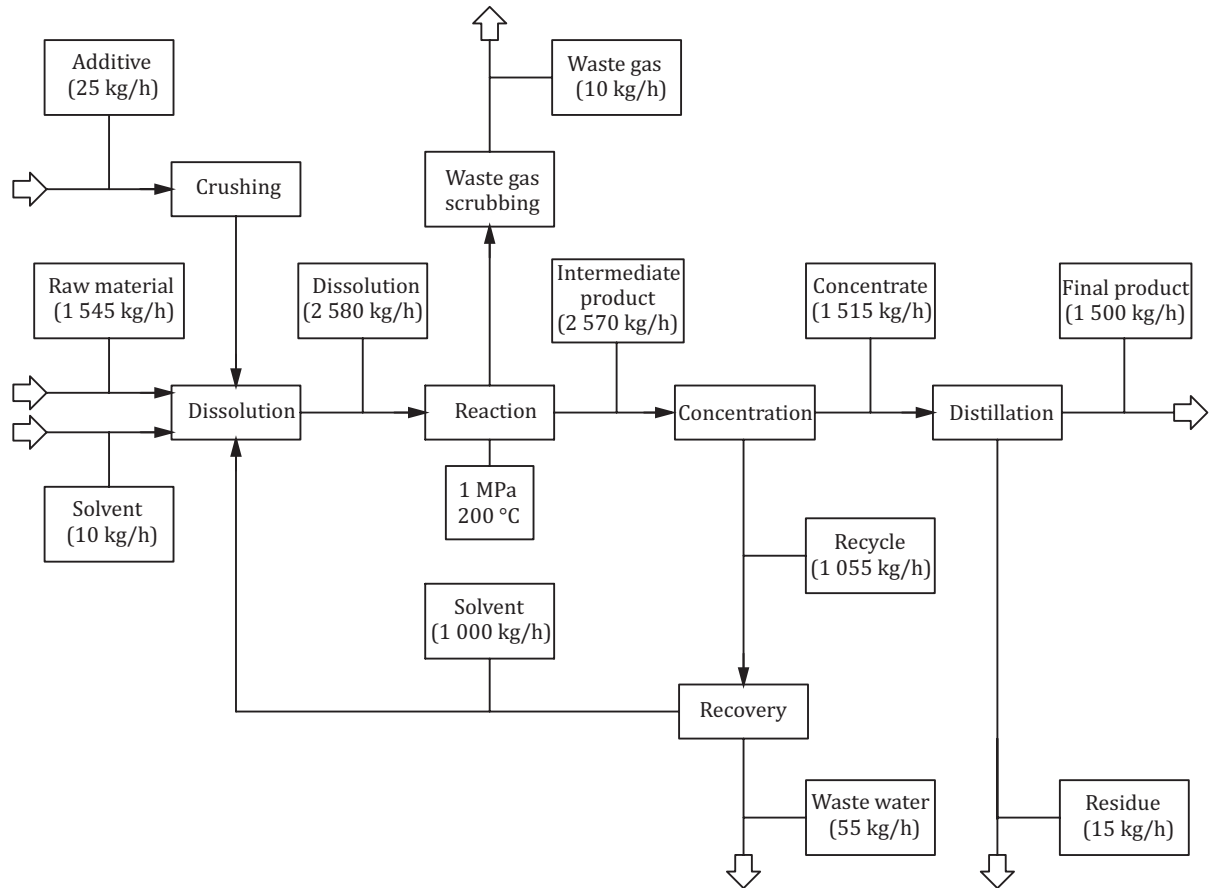
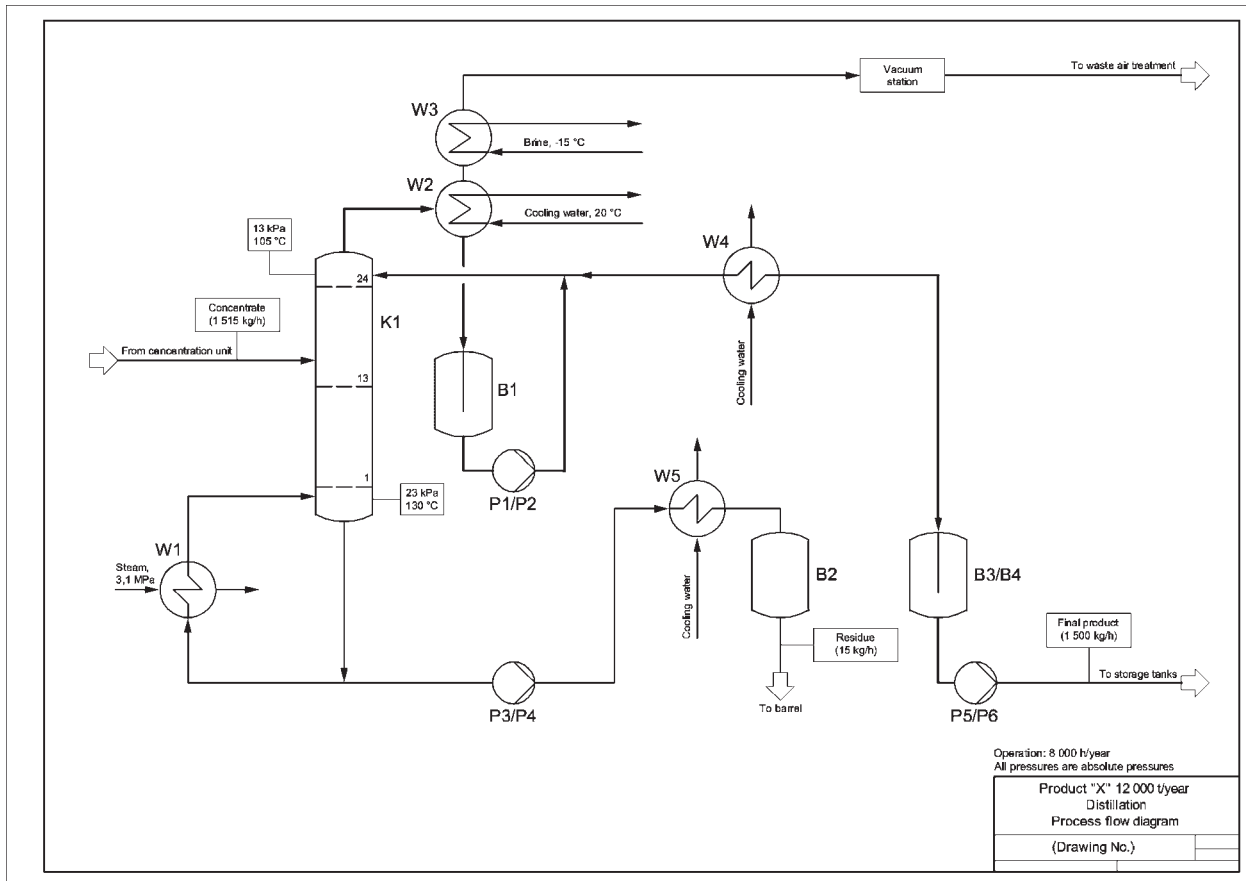

Figure A.2 — Block diagram with basic and additional information



NOTE Alternative designations for devices and equipment with backup redundancy can be assigned using suffix letters (e.g. P1 A/B).

Figure A.3 — Process flow diagram with basic information

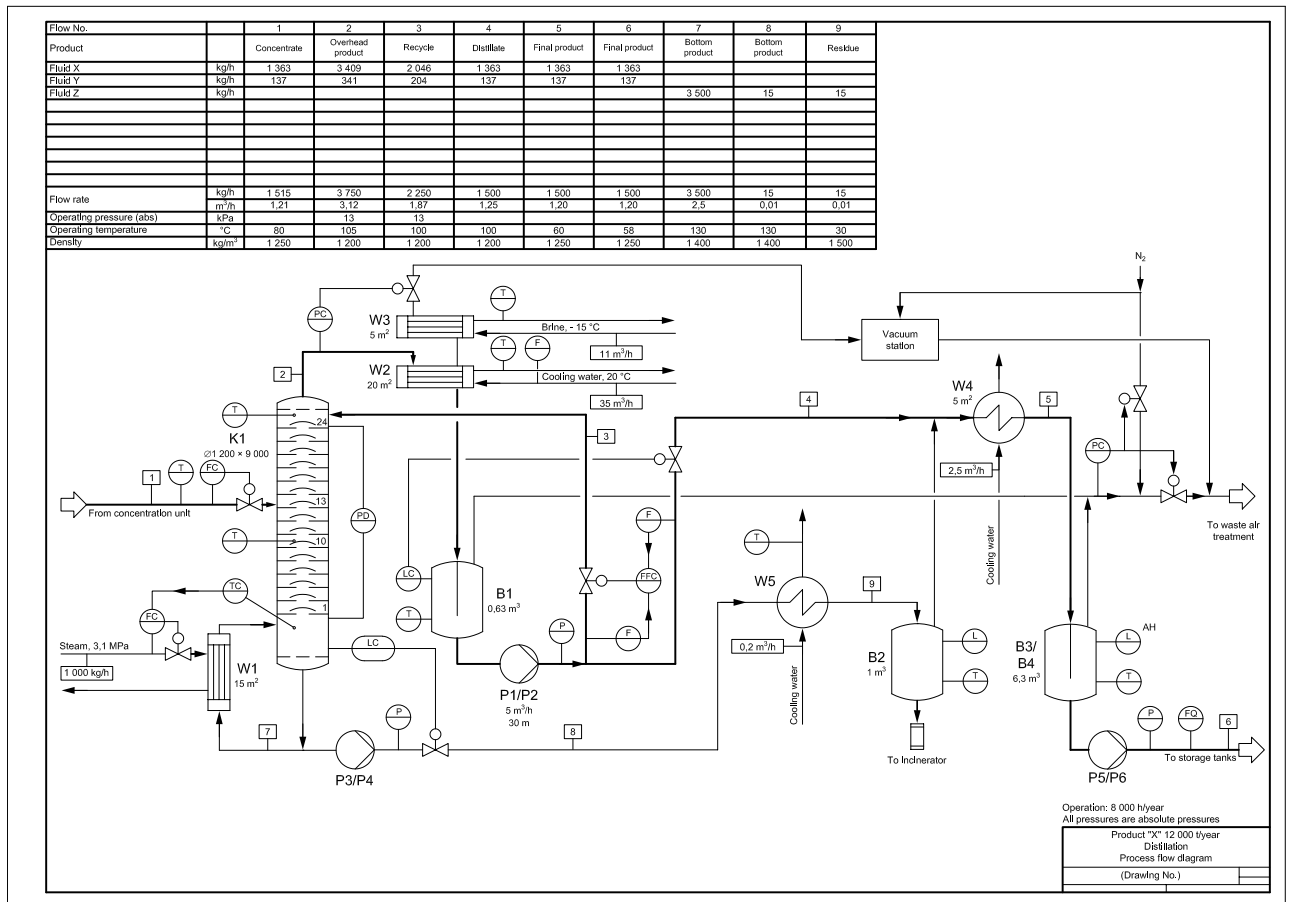

Figure A.4 — Process flow diagram with basic and additional information

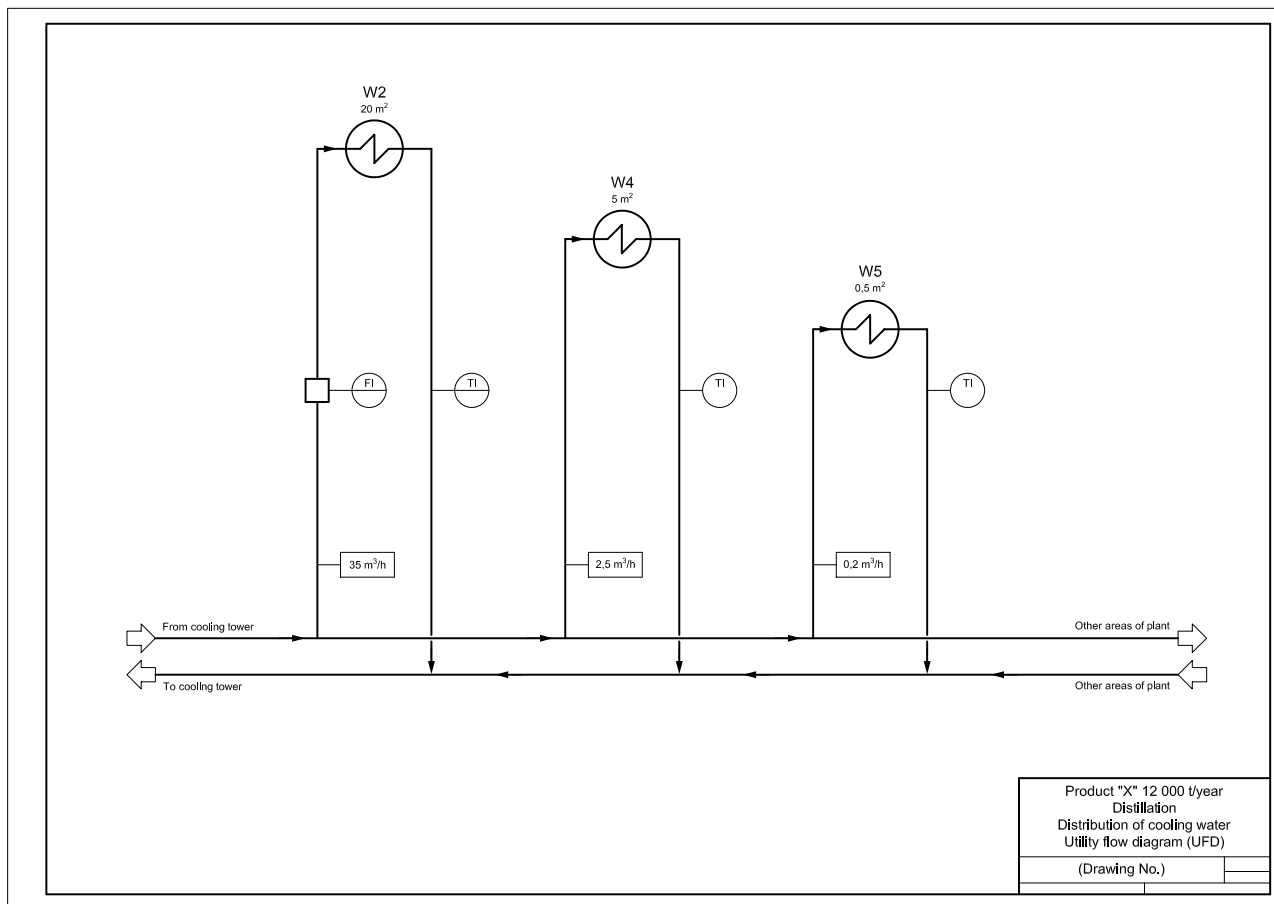
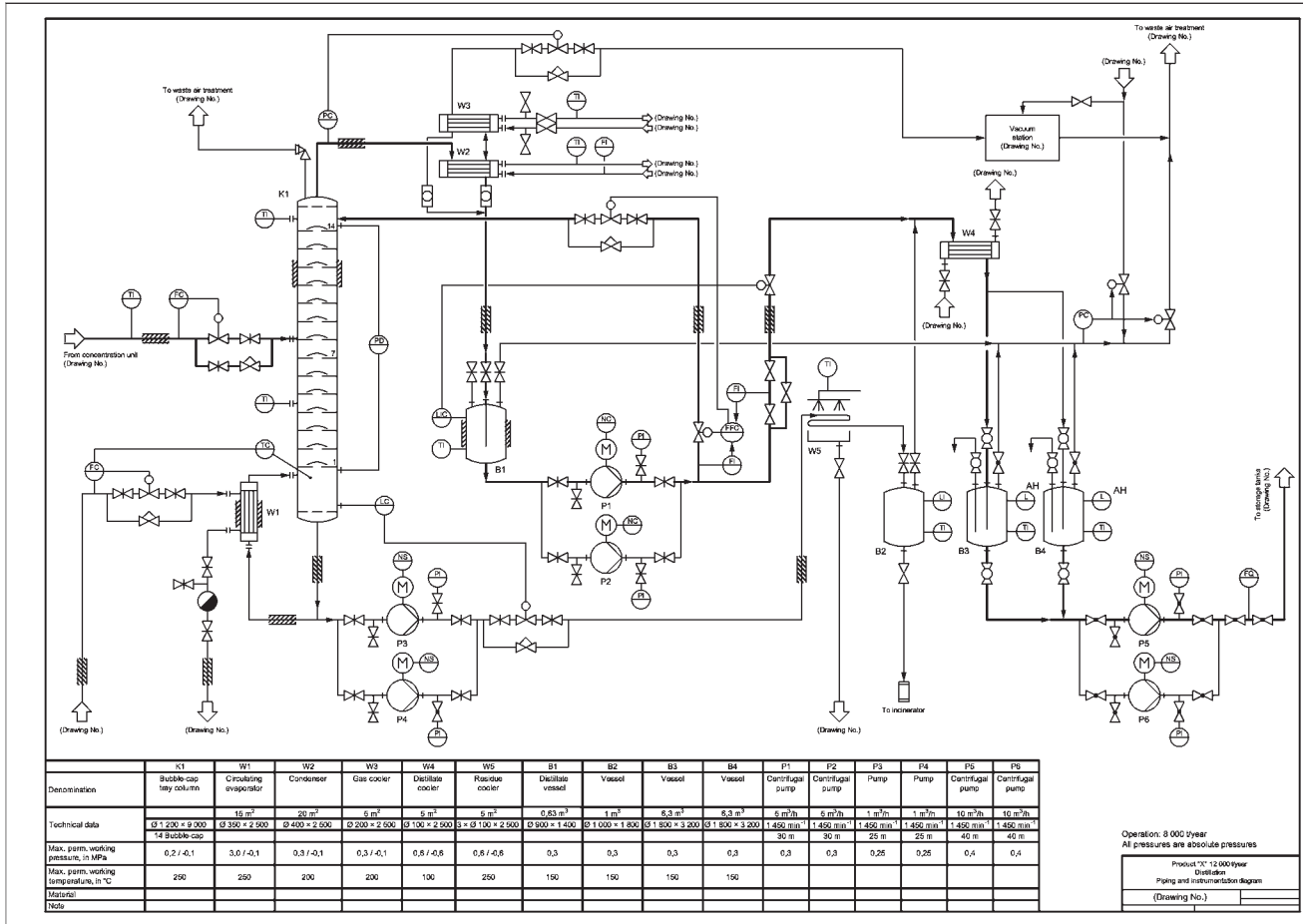

Figure A.5 — Process flow diagram as utility flow diagram (UFD)



NOTE 1 As an alternative to the pump designation (pump aggregate), one of the following designations can be assigned to the pump and the associated motor:



NOTE 2 This identification method is particularly suitable for aggregates that have more than one motor.

Figure A.6 — Piping and instrumentation diagram (P&ID) with basic information

Bibliography

- [1] ISO 3098-2, *Technical product documentation — Lettering — Part 2: Latin alphabet, numerals and marks*
- [2] ISO 5457, *Technical product documentation — Sizes and layout of drawing sheets*
- [3] ISO 80416-2:2001, *Basic principles for graphical symbols for use on equipment — Part 2: Form and use of arrows*

