**Rubber and plastics hoses and
tubing — Measurement of flexibility and
stiffness —**

**Part 2:
Bending tests at sub-ambient
temperatures**

*Tuyaux et tubes en caoutchouc et en plastique — Mesurage de la
flexibilité et de la rigidité —*

*Partie 2: Essais de courbure à des températures inférieures à
l'ambiante*





COPYRIGHT PROTECTED DOCUMENT

© ISO 2011

All rights reserved. Unless otherwise specified, no part of this publication may be reproduced or utilized in any form or by any means, electronic or mechanical, including photocopying and microfilm, without permission in writing from either ISO at the address below or ISO's member body in the country of the requester.

ISO copyright office
Case postale 56 • CH-1211 Geneva 20
Tel. + 41 22 749 01 11
Fax + 41 22 749 09 47
E-mail copyright@iso.org
Web www.iso.org

Published in Switzerland

Foreword

ISO (the International Organization for Standardization) is a worldwide federation of national standards bodies (ISO member bodies). The work of preparing International Standards is normally carried out through ISO technical committees. Each member body interested in a subject for which a technical committee has been established has the right to be represented on that committee. International organizations, governmental and non-governmental, in liaison with ISO, also take part in the work. ISO collaborates closely with the International Electrotechnical Commission (IEC) on all matters of electrotechnical standardization.

International Standards are drafted in accordance with the rules given in the ISO/IEC Directives, Part 2.

The main task of technical committees is to prepare International Standards. Draft International Standards adopted by the technical committees are circulated to the member bodies for voting. Publication as an International Standard requires approval by at least 75 % of the member bodies casting a vote.

Attention is drawn to the possibility that some of the elements of this document may be the subject of patent rights. ISO shall not be held responsible for identifying any or all such patent rights.

ISO 10619-2 was prepared by Technical Committee ISO/TC 45, *Rubber and rubber products*, Subcommittee SC 1, *Hoses (rubber and plastics)*.

This first edition cancels and replaces ISO 4672:1997, which has been technically revised.

ISO 10619 consists of the following parts, under the general title *Rubber and plastics hoses and tubing — Measurement of flexibility and stiffness*:

- *Part 1: Bending tests at ambient temperature*
- *Part 2: Bending tests at sub-ambient temperatures*
- *Part 3: Bending tests at high and low temperatures*

.....

Rubber and plastics hoses and tubing — Measurement of flexibility and stiffness —

Part 2: Bending tests at sub-ambient temperatures

WARNING — Persons using this part of ISO 10619 should be familiar with normal laboratory practice. This part of ISO 10619 does not purport to address all of the safety problems, if any, associated with its use. It is the responsibility of the user to establish appropriate safety and health practices and to ensure compliance with any national regulatory conditions.

1 Scope

This part of ISO 10619 specifies two methods for measuring the stiffness and one method for the determination of the flexibility of rubber and plastics hoses and tubing when they are bent to a specific radius at sub-ambient temperatures.

Method A is suitable for non-collapsible rubber and plastics hoses and tubing with a bore of up to and including 25 mm. This method provides a means of measuring the stiffness of the hose or tubing when the temperature is reduced from a standard laboratory temperature.

Method B is suitable for rubber and plastics hoses and tubing with a bore of up to 100 mm and provides a means of assessing the flexibility of the hose or tubing when bent around a mandrel at a specified sub-ambient temperature. It can also be used as a routine quality control test.

Method C is suitable for rubber and plastics hoses and tubing with a bore of 100 mm and greater. This method provides a means of measuring the stiffness of the hose and tubing at sub-ambient temperatures. This method is only suitable for hoses and tubing which are non-collapsible.

2 Normative references

The following referenced documents are indispensable for the application of this document. For dated references, only the edition cited applies. For undated references, the latest edition of the referenced document (including any amendments) applies.

ISO 1402, *Rubber and plastics hoses and hose assemblies — Hydrostatic testing*

ISO 8330, *Rubber and plastics hoses and hose assemblies — Vocabulary*

ISO 23529, *Rubber — General procedures for preparing and conditioning test pieces for physical test methods*

3 Terms and definitions

For the purposes of this document, the terms and definitions given in ISO 8330 and the following apply.

3.1

bending

shaping or forcing something straight into a curve or angle at a specified temperature

3.2

flexibility

ease of bending a hose without it being damaged by kinking, collapse, breaking or cracking

NOTE A hose can be bent around a mandrel, for example.

3.3

stiffness

resistance of a hose to bending

4 Method A

This method applies to non-collapsible hoses with a bore of up to and including 25 mm only.

4.1 Apparatus

4.1.1 Torque wheel, having a diameter equal to twice the minimum bend radius specified for the hose, provided with equipment for holding the hose tangential to the wheel, a suitable device to bend the hose around the wheel, and a strain gauge and graphical recorder to measure the torque with an accuracy of $\pm 3\%$ (see Figure 1). If the minimum bend radius is not specified, the torque wheel shall have a diameter equal to 12 times the nominal bore of the hose (see Figure 1).

4.1.2 Cooling container, equipped with an agitator, a temperature-measuring device and a roller having a diameter of 50 mm for guiding the hose (see Figure 1). The coolant shall not affect the hose under test and shall be used as prescribed in ISO 23529. A suitable coolant liquid is methanol or ethanol with crushed dry ice (solid carbon dioxide) added. Gaseous coolants may be employed when the design of the apparatus is such that the tests using such coolants give results equivalent to those obtained with liquid coolants.

4.2 Hose test piece

4.2.1 Type

The hose test pieces shall be cut from the hose under test and shall have a length equal to:

$$2(\pi R + d) \tag{1}$$

where

R is the minimum bend radius as specified in the relevant hose product standard;

d is the hose bore.

4.2.2 Number of hose test pieces

At least three hose test pieces shall be used for each test.

No test shall be carried out less than 24 h after manufacture of the hose.

4.3 Test temperature

The test shall be conducted at one of the following temperatures:

0 °C \pm 2 °C

-10 °C \pm 2 °C

-25 °C \pm 2 °C

–40 °C ± 2 °C

–55 °C ± 2 °C

or any other sub-ambient temperature as defined in the relevant product standard.

4.4 Procedure

Clamp one end of the hose test piece (4.2) on the wheel (4.1.1), with the rest of the test piece straight. If the hose has natural curvature, this curvature shall follow that of the wheel.

Without coolant in the container (4.1.2), determine the torque required to bend the test specimen through 180° round the wheel at the standard temperature chosen from those given in ISO 25329. The time for bending shall be (12 ± 2) s. Repeat the test with the container filled with coolant at the chosen test temperature (see 4.3). Condition the hose test piece in a cold chamber at the test temperature for 24 h followed by conditioning at the test temperature in the apparatus for at least 30 min before testing.

4.5 Expression of results

For each hose test piece, calculate the mean torque at the standard temperature and the mean torque at the test temperature by calculating the mean of the peak values contained in the central 50 % of the respective torque traces.

Calculate the stiffness, S , expressed as the ratio of the mean torque at the test temperature to that at the standard temperature, from Equation (2):

$$S = \frac{T_t}{T_o} \quad (2)$$

where

T_t is the torque at the test temperature (mean value from three tests);

T_o is the torque at the standard temperature (mean value from the three tests).

If the individual values for the three test specimens do not agree to within 15 % of the mean value at each temperature, the test shall be repeated.

4.6 Test report

The test report shall include the following:

- a) reference to this part of ISO 10619, i.e. ISO 10619-2:2011;
- b) a full description of the hose and its origin;
- c) the dimensions of the hose test pieces;
- d) the coolant used;
- e) the standard temperature and the test temperature;
- f) the torque at the standard temperature, T_o , and at the test temperature, T_t ;
- g) the calculated value of the stiffness, S ;
- h) the date of the test.

5 Method B

This method applies to hoses and tubing with a bore size of up to 100 mm only.

5.1 Apparatus

5.1.1 Mandrel, having an outside diameter equal to twice the minimum bend radius specified for the hose, or a former, with an arc of at least 180°. If the minimum bend radius is not specified, the mandrel or former shall have an outside diameter equal to 12 times the bore of the hose.

5.1.2 Conditioning chamber, capable of being maintained at the specified temperature (see 5.3).

5.1.3 For hoses with a bore greater than 22 mm that need to be flexed outside the conditioning chamber an example of a test rig that may be used is shown in Figure 2. A pneumatic ram pushes the mandrel so as to contact the hose sample and bend it around the mandrel.

5.2 Hose test pieces

The hose test piece shall be cut from the hose under test and shall have a length at least greater than 10 % of the circumference of the mandrel used. The sample should be long enough to allow the sample to be gripped at each end in addition to the section which will be bent around the periphery of the mandrel.

The test specimen shall be discarded on completion of the test.

5.3 Test temperature

The test shall be conducted at one of the following temperatures:

0 °C ± 2 °C

–10 °C ± 2 °C

–25 °C ± 2 °C

–40 °C ± 2 °C

–55 °C ± 2 °C

or any other sub-ambient temperature as defined in the relevant product standard.

5.4 Procedure

Condition the mandrel (5.1.1) and the hose test piece (5.2) in the conditioning chamber (5.1.2) at the chosen test temperature (see 5.3) for 24 h. Without removing them from the conditioning chamber, bend around the mandrel, hoses up to and including 22 mm bore through 180° in less than 10 s and hoses greater than 22 mm bore through 180° in less than 12 s.

For hoses of greater than 22 mm bore, testing outside the conditioning chamber is permitted, using apparatus shown in Figure 2 (if the sample cannot be bent by hand). The sample should be bent around the mandrel in less than 12 s after removal from the cold box.

Observe whether any cracking or breaking of the hose cover occurs during the bending.

After bending, allow the hose test piece to regain ambient temperature and apply the specified proof test pressure, measured accurately in accordance with ISO 1402. Examine the lining for cracks after proof pressure test.

5.5 Test report

The test report shall include the following:

- a) a reference to this part of ISO 10619, i.e. ISO 10619-2:2011;
- b) a full description of the hose and its origin;

- c) the dimension of the hose test piece;
- d) the test temperature;
- e) the outside diameter of the mandrel used;
- f) the results of the visual examination of the hose test piece after bending;
- g) the results of the visual examination after the proof pressure test;
- h) the date of the test.

6 Method C

This method applies to non-collapsible hoses of bore size 100 mm and greater.

6.1 Apparatus

6.1.1 Apparatus for testing of bending stiffness, as shown in Figure 3. The hose is placed on three support trolleys placed underneath the hose at either end and at the middle of the hose sample. The trolleys should be of a suitable design so as to move freely when the hose is being bent.

6.1.2 Conditioning chamber, capable of being maintained at the specified temperature (see 6.3).

The ends of the hose are connected to a suitable tensioning device, capable of bending the hose to its minimum bend radius, R .

6.2 Hose test piece

The testing shall be carried out on a finished hose.

6.3 Test temperature

The test shall be conducted at one of the following temperatures:

0 °C ± 5 °C

–10 °C ± 5 °C

–25 °C ± 5 °C

–40 °C ± 5 °C

–55 °C ± 5 °C

or any other sub-ambient temperature as defined in the relevant product standard.

6.4 Procedure

With the hose test piece empty and straight, a 1m reference length shall be marked on the centre line of the hose at the hose centre, as shown in Figure 3. The ends of the hose shall be blocked before the hose is thermally conditioned.

The hose test piece shall be bent until the hose has reached its minimum bend radius, R , and then allowed to relax to its unloaded condition. Each cycle time (the act of bending the hose) shall be a minimum of 10 min and the relaxing time between each cycle shall be 5 min maximum. The roller system on the hose support trolleys shall be sufficiently friction free so that the induced error is negligible. This procedure is repeated at least four times, but not more than seven times ensuring that the bending arc is as close as possible to the original bending arc used.

The pull load, (as indicated by the dynamometer after a period of 5 min from the end of the load application) shall not vary by more than 23 kg force between the last two consecutive pulls; if not, continue until the 7th cycle is reached and register the load, P .

Record the dimensions, L , C and H , shown in Figure 3 after the last pull; they shall be used to calculate the flexural stiffness. The chord, C , measured between the reference marks will be less than 1,0 m.

6.5 Expression of results

The flexural stiffness, EI , is calculated using the following equation:

$$EI = MR \quad (3)$$

where

$$M = PL \quad (4)$$

and

$$R = \frac{C^2 + 4H^2}{8H} \quad (5)$$

where

M is the bending moment at the hose centre, expressed in kilograms per metre (kg/m);

P is the dynamometer load, expressed in kilograms (kg);

L is the moment arm, expressed in metres (m);

R is the minimum bend radius at hose centre, expressed in metres (m);

C is the chord of the bending arc, expressed in metres (m);

H is the offset, expressed in metres (m).

6.6 Test report

The test report shall include the following:

- a) a reference to this part of ISO 10619, i.e. ISO 10619-2:2011;
- b) a full description of the hose and its origin;
- c) the dimensions of the hose test piece;
- d) the pressure under which the test was done, if applicable;
- e) the temperature at which the test was performed;
- f) the curvature of the hose under which the test was performed;
- g) minimum bend radius of the hose, if required;
- h) the calculated value of the stiffness, EI ;
- i) the date of the test.

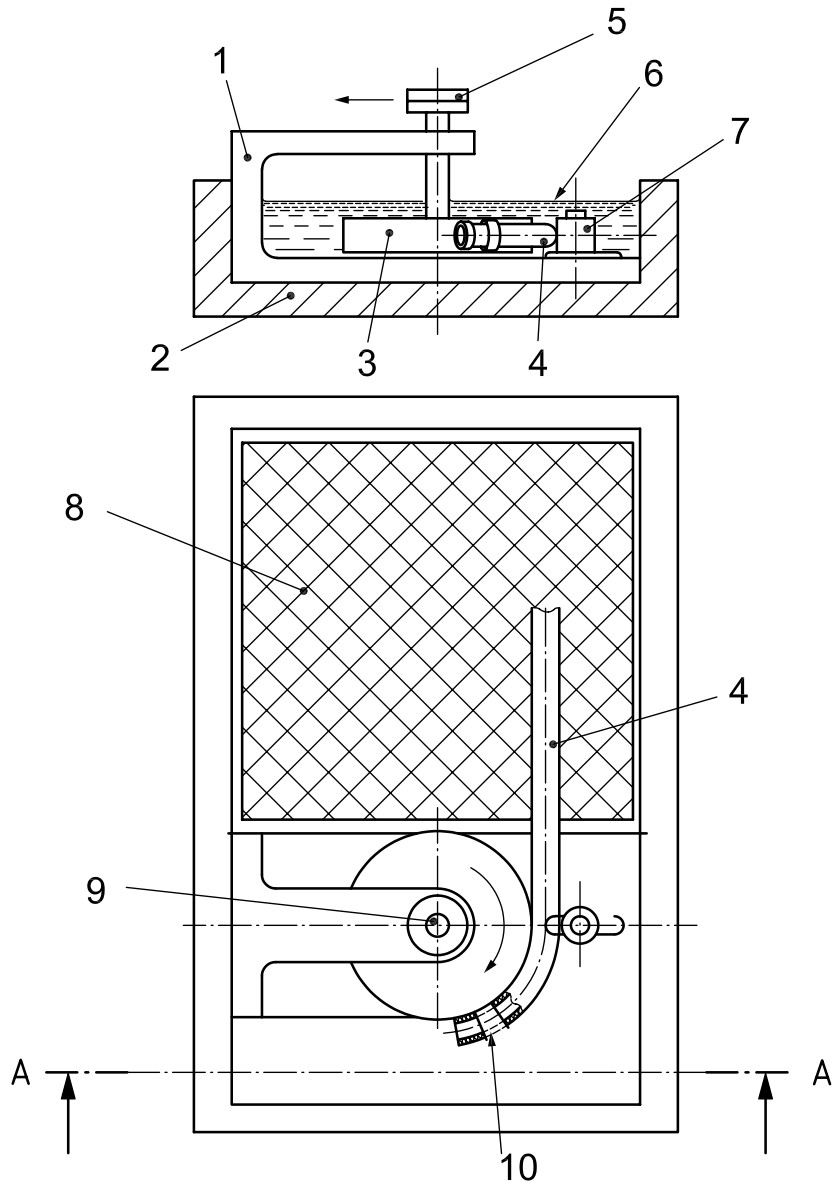

Key

- 1 stand
- 2 coolant container
- 3 torque wheel
- 4 hose test piece
- 5 torque-measuring device
- 6 coolant
- 7 roller for guiding the hose
- 8 net for support of hose test piece
- 9 bearing
- 10 anchor for end of hose test piece

Figure 1 — Test apparatus with torque wheel and coolant container

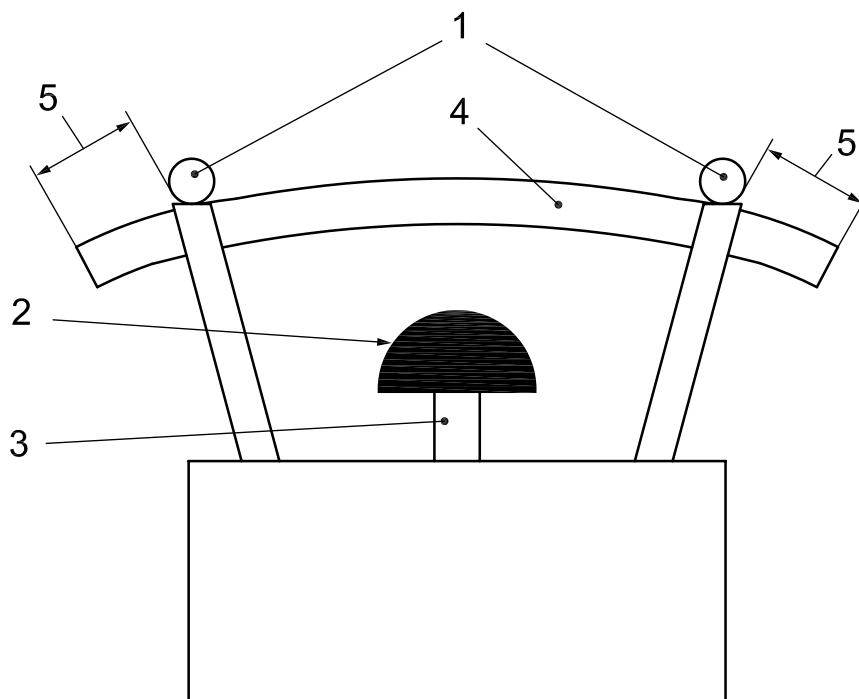

Key

- 1 rollers
- 2 mandrel
- 3 pneumatic ram
- 4 hose test piece
- 5 extra hose length (see recommendation below)

The hose test piece should be long enough so that the sample remains in the test fixture during bending.

Figure 2 — Example of apparatus used for flexing samples at sub-ambient temperatures

Dimensions in millimetres

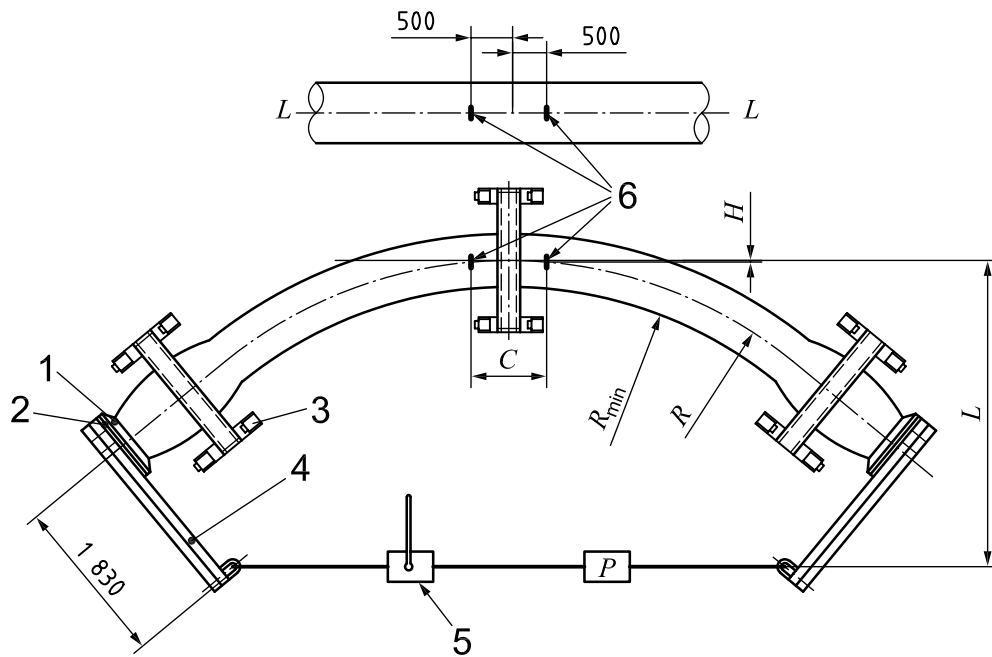

Key

- 1 hose flange
- 2 test plate
- 3 trolley to allow for movement of hose
- 4 hose bending beam
- 5 tension device
- 6 test marks
- C* chord of bending arc
- H* offset
- L* moment arm
- P* cable tension/dynamometer load
- R* bend radius at hose centre line
- R_{min}* minimum bend radius

Figure 3 — Method for flexural stiffness testing

ICS 23.040.70

Price based on 9 pages