

INTERNATIONAL
STANDARD

ISO
10591

Second edition
2005-07-01

**Building construction — Sealants —
Determination of adhesion/cohesion
properties of sealants after immersion in
water**

*Construction immobilière — Produits pour joints — Détermination des
propriétés d'adhésivité/cohésion des mastics après immersion dans
l'eau*



Reference number
ISO 10591:2005(E)

© ISO 2005

PDF disclaimer

This PDF file may contain embedded typefaces. In accordance with Adobe's licensing policy, this file may be printed or viewed but shall not be edited unless the typefaces which are embedded are licensed to and installed on the computer performing the editing. In downloading this file, parties accept therein the responsibility of not infringing Adobe's licensing policy. The ISO Central Secretariat accepts no liability in this area.

Adobe is a trademark of Adobe Systems Incorporated.

Details of the software products used to create this PDF file can be found in the General Info relative to the file; the PDF-creation parameters were optimized for printing. Every care has been taken to ensure that the file is suitable for use by ISO member bodies. In the unlikely event that a problem relating to it is found, please inform the Central Secretariat at the address given below.

© ISO 2005

All rights reserved. Unless otherwise specified, no part of this publication may be reproduced or utilized in any form or by any means, electronic or mechanical, including photocopying and microfilm, without permission in writing from either ISO at the address below or ISO's member body in the country of the requester.

ISO copyright office
Case postale 56 • CH-1211 Geneva 20
Tel. + 41 22 749 01 11
Fax + 41 22 749 09 47
E-mail copyright@iso.org
Web www.iso.org

Published in Switzerland

Contents

Page

Foreword.....	iv
1 Scope	1
2 Normative references	1
3 Terms and definitions.....	1
4 Principle.....	1
5 Apparatus	1
6 Preparation of test specimens	2
7 Conditioning of test specimens	2
8 Test procedure	3
9 Expression of results	3
10 Test report	3

Foreword

ISO (the International Organization for Standardization) is a worldwide federation of national standards bodies (ISO member bodies). The work of preparing International Standards is normally carried out through ISO technical committees. Each member body interested in a subject for which a technical committee has been established has the right to be represented on that committee. International organizations, governmental and non-governmental, in liaison with ISO, also take part in the work. ISO collaborates closely with the International Electrotechnical Commission (IEC) on all matters of electrotechnical standardization.

International Standards are drafted in accordance with the rules given in the ISO/IEC Directives, Part 2.

The main task of technical committees is to prepare International Standards. Draft International Standards adopted by the technical committees are circulated to the member bodies for voting. Publication as an International Standard requires approval by at least 75 % of the member bodies casting a vote.

Attention is drawn to the possibility that some of the elements of this document may be the subject of patent rights. ISO shall not be held responsible for identifying any or all such patent rights.

ISO 10591 was prepared by Technical Committee ISO/TC 59, *Building construction*, Subcommittee SC 8, *Joining products*.

This second edition cancels and replaces the first edition (ISO 10591:1991), Clauses 2, 5, 6, and 7 of which have been technically revised.

Building construction — Sealants — Determination of adhesion/cohesion properties of sealants after immersion in water

1 Scope

This International Standard specifies a method for the determination of the influence of water on the adhesion/cohesion properties of sealants with predominantly plastic behaviour which are used in joints in building construction.

2 Normative references

The following referenced documents are indispensable for the application of this document. For dated references, only the edition cited applies. For undated references, the latest edition of the referenced document (including any amendments) applies.

ISO 6927, *Building construction — Jointing products — Sealants — Vocabulary*

ISO 13640, *Building construction — Jointing products — Specifications for test substrates*

3 Terms and definitions

For the purposes of this document, the definitions given in ISO 6927 apply.

4 Principle

Test specimens are prepared in which the sealant to be tested adheres to two parallel contact surfaces. After submission of the test specimens to water immersion under defined conditions, the test specimens are extended to rupture and the elongation at break recorded.

5 Apparatus

5.1 Substrate materials, used for the preparation of test specimens, are defined in ISO 13640, *Specification for test substrates*. The substrate materials shall be selected from mortar and/or anodized aluminium and/or glass. Other substrate materials may be used as agreed by the parties concerned.

For each test specimen, two substrate pieces of the same material are required, with a cross-section of dimensions as shown in Figures 1 and 2. Test substrates of other dimensions may be used, but then the dimensions of the sealant bead and the area of adhesion shall be the same as those shown in Figures 1 and 2.

5.2 Spacers, for the preparation of the test specimens, of cross-section (12 mm × 12 mm) with anti-adherent surface (see Figures 1 and 2).

5.3 Anti-adherent substrate, for the preparation of test specimens, e.g. polyethylene (PE) film, preferably according to the advice of the sealant manufacturer.

- 5.4 **Ventilated convection-type oven**, capable of being maintained at $(70 \pm 2) ^\circ\text{C}$ (conditioning method B).
- 5.5 **Container**, for distilled water immersion at $(23 \pm 2) ^\circ\text{C}$ (conditioning method B).
- 5.6 **Container**, for water immersion of test specimens at $(23 \pm 2) ^\circ\text{C}$.
- 5.7 **Test machine**, capable of extending the test specimens at a rate of $(5,5 \pm 0,7) \text{ mm/min}$.

6 Preparation of test specimens

The sealant and the substrate shall be brought to $(23 \pm 2) ^\circ\text{C}$. For each substrate material, three test specimens shall be prepared. For each test specimen, two substrates (5.1) and two spacers (5.2) shall be assembled (see Figures 1 and 2) and set on the anti-adherent substrate (5.3).

The instructions of the sealant manufacturer shall be followed concerning, for instance, whether a primer is to be used and the mixing procedure for multi-component sealants. The hollow volume formed by the substrates shall be filled with the sealant.

The following precautions shall be taken:

- a) the formation of air bubbles shall be avoided;
- b) the sealant shall be pressed to the contact surfaces of the substrates;
- c) the sealant surface shall be trimmed so that it is flush with the faces of the substrates and the spacers.

The specimens shall be set on the edge of one of the substrates. The anti-adherent substrate shall be removed as soon as possible. The specimens shall be kept in this position to allow curing or optimum drying of the sealant.

The spacers shall be maintained in place during conditioning.

7 Conditioning of test specimens

7.1 General

The test specimens shall be conditioned either in accordance with method A (7.2) or method B (7.3), as agreed between the parties concerned.

7.2 Conditioning method A

The test specimens shall be conditioned for 28 days at $(23 \pm 2) ^\circ\text{C}$ and $(50 \pm 5) \%$ relative humidity.

7.3 Conditioning method B

The test specimens shall be conditioned according to method A and shall then be subjected three times to the following storage cycle:

- a) three days in the oven (5.4) at $(70 \pm 2) ^\circ\text{C}$;
- b) one day in distilled water (5.5) at $(23 \pm 2) ^\circ\text{C}$;
- c) two days in the oven (5.4) at $(70 \pm 2) ^\circ\text{C}$;
- d) one day in distilled water (5.5) at $(23 \pm 2) ^\circ\text{C}$.

Alternatively, this cycle may be carried out in the order c), d), a), b).

After conditioning according to method B, the test specimens shall be stored for 24 h at $(23 \pm 2)^\circ\text{C}$ and $(50 \pm 5)\%$ relative humidity before testing.

NOTE Method B is a normal conditioning procedure using the influence of heat and water. It is not suitable for giving information on the durability of the sealant.

8 Test procedure

After conditioning according to method A or method B, the spacers shall be removed. The test specimens shall be immersed for four days in water at a temperature of $(23 \pm 2)^\circ\text{C}$ (5.6) and stored one day in air at $(23 \pm 2)^\circ\text{C}$ and $(50 \pm 5)\%$ relative humidity. The test specimens shall be placed in the tensile test machine (5.7) and extended at a rate of $(5,5 \pm 0,7)$ mm/min until break. The force/extension diagram shall be recorded.

9 Expression of results

For each test specimen, the arithmetic mean of the three elongations to break shall be calculated and rounded to 5 %.

$$\text{Elongation (\%)} = [(\text{final width} - \text{original width}) / \text{original width}] \times 100$$

10 Test report

The test report shall contain the following information

- a) test laboratory's name and date of testing;
- b) reference to this International Standard;
- c) name, type (chemical family) and colour of sealant;
- d) batch of sealant from which the test specimens were produced;
- e) the substrate materials used (see 5.1);
- f) the primer(s) used, if applicable;
- g) the conditioning method used;
- h) force/extension diagrams of the test specimens,
- i) the percentage elongation at break of each test specimen;
- j) the arithmetic mean of the three elongations at break;
- k) type of failure (adhesive or cohesive or mixed);
- l) any deviation from this International Standard.

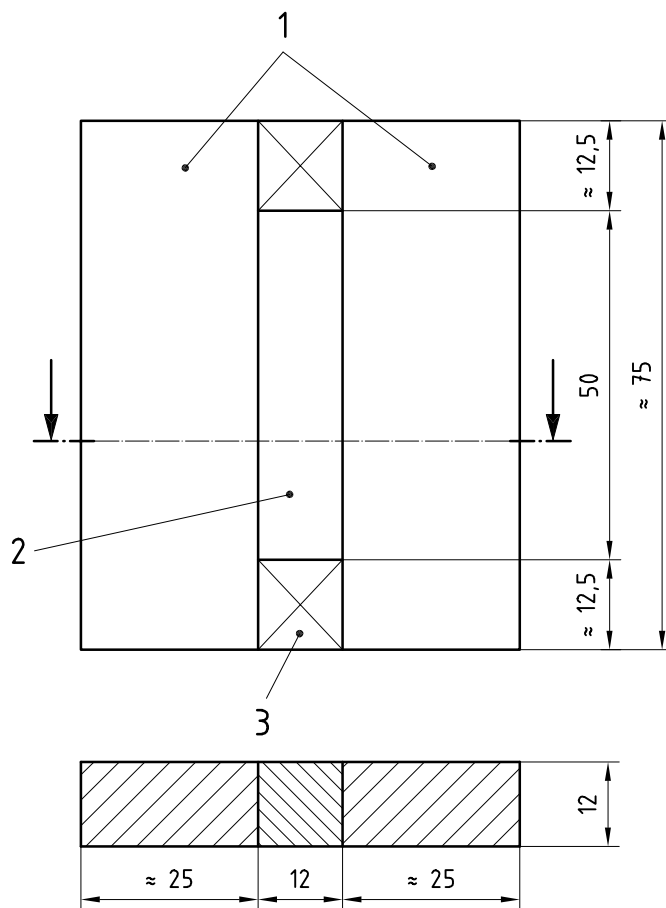

Key

- 1 mortar substrates
- 2 sealant
- 3 spacers (5.2)

Figure 1 — Test specimens with mortar substrates

Dimensions in millimetres

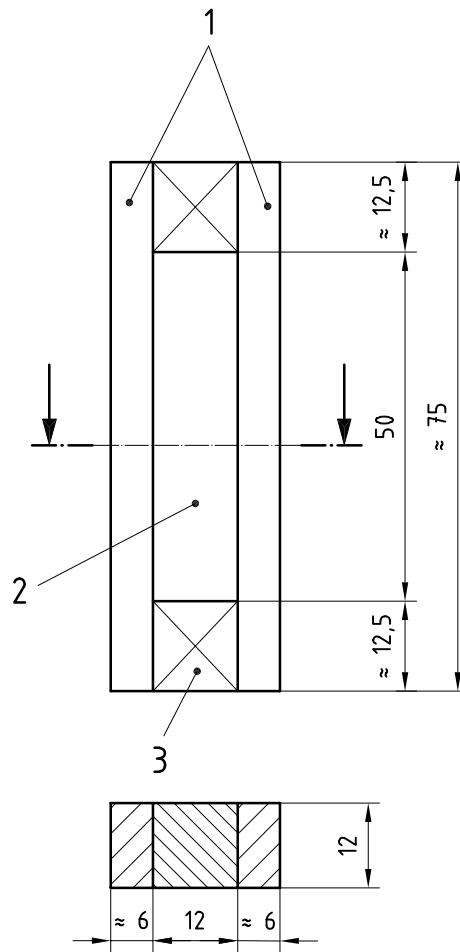

Key

- 1 anodized aluminium or glass substrates
- 2 sealant
- 3 spacers (5.2)

Figure 2 — Test specimens with anodized aluminium or glass substrates

ICS 91.100.50

Price based on 5 pages